

# Power Circuit

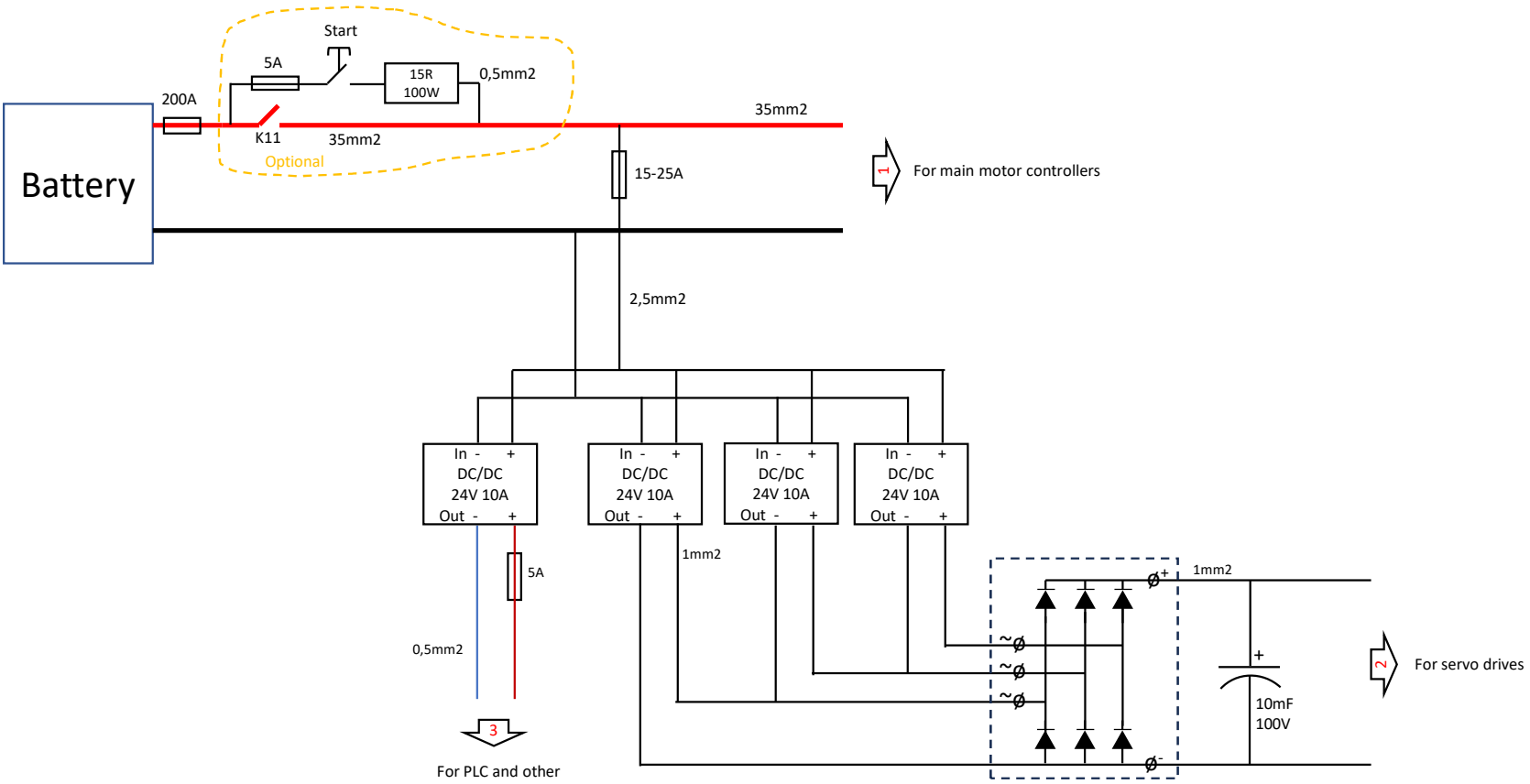

# PLC outputs

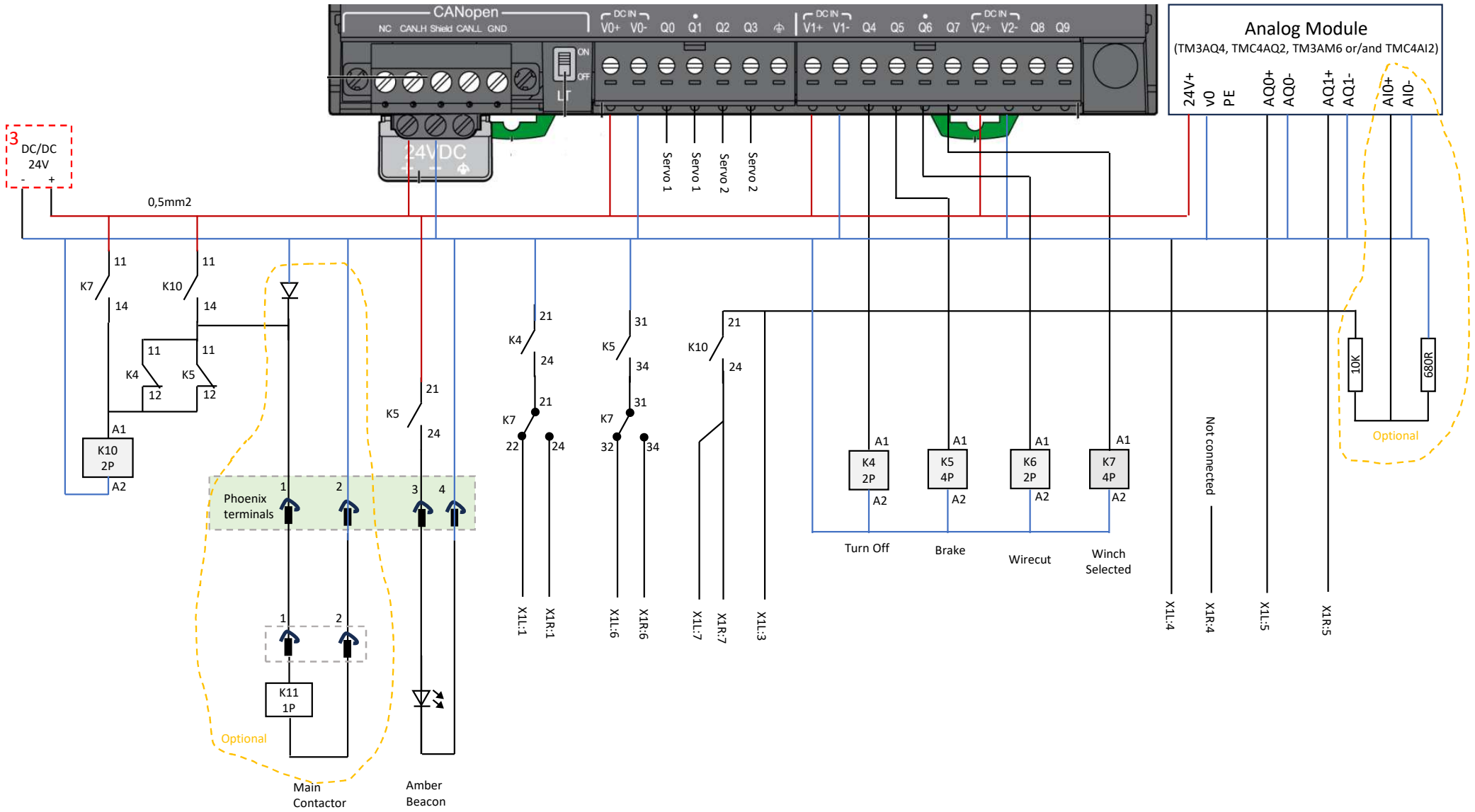

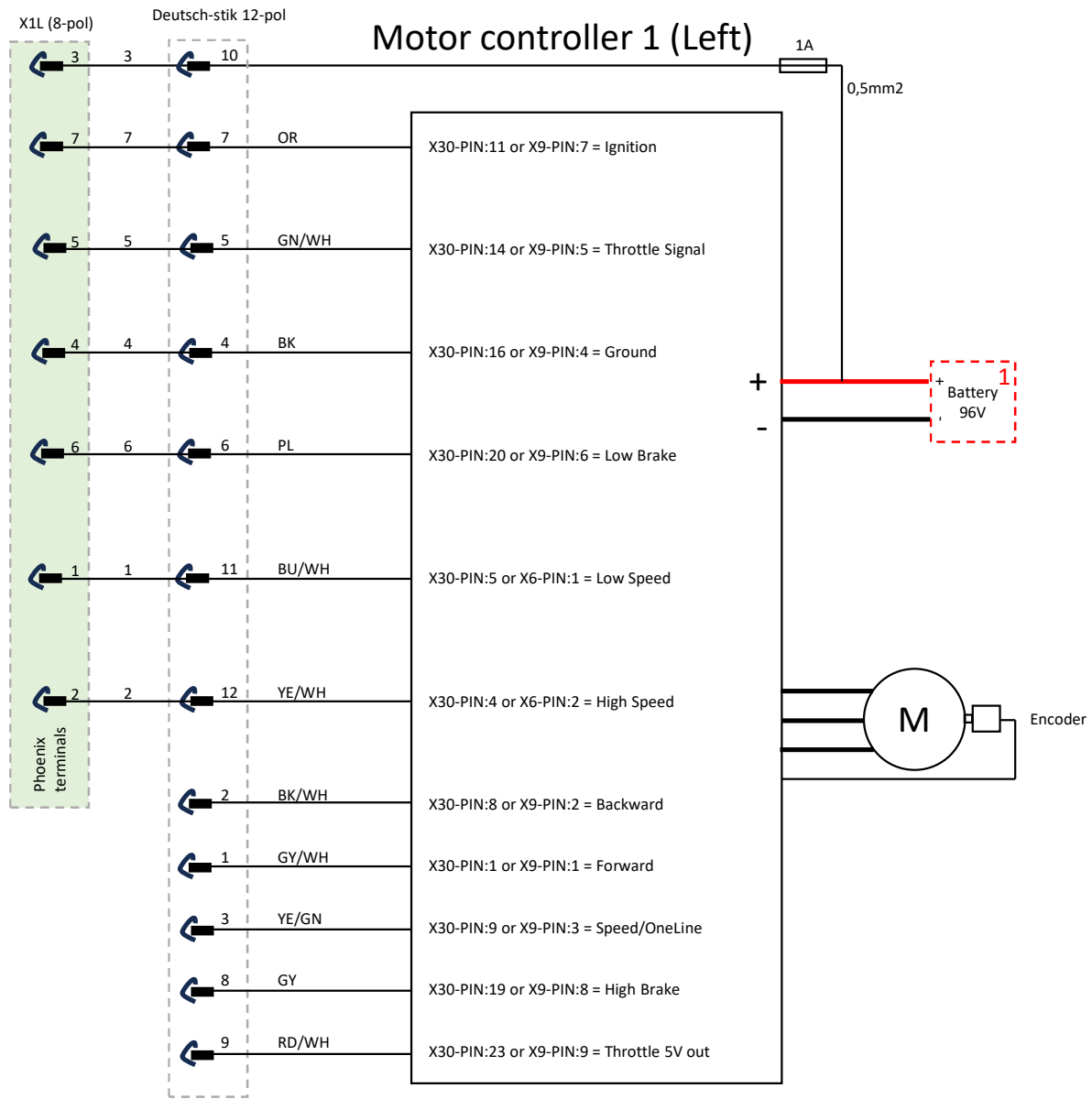

# Motor controller 2 (Right)

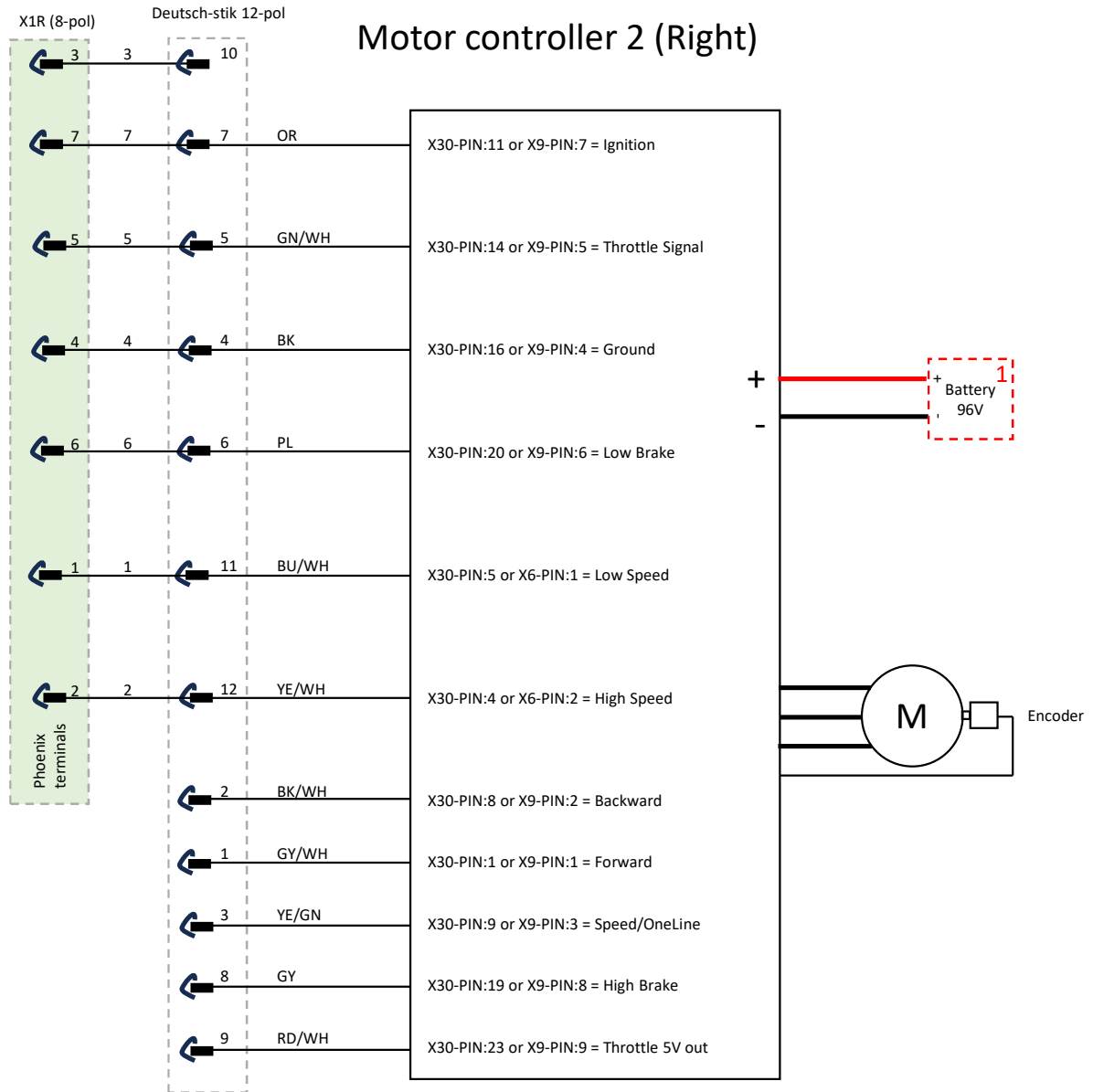

# Servo 1 (Left)

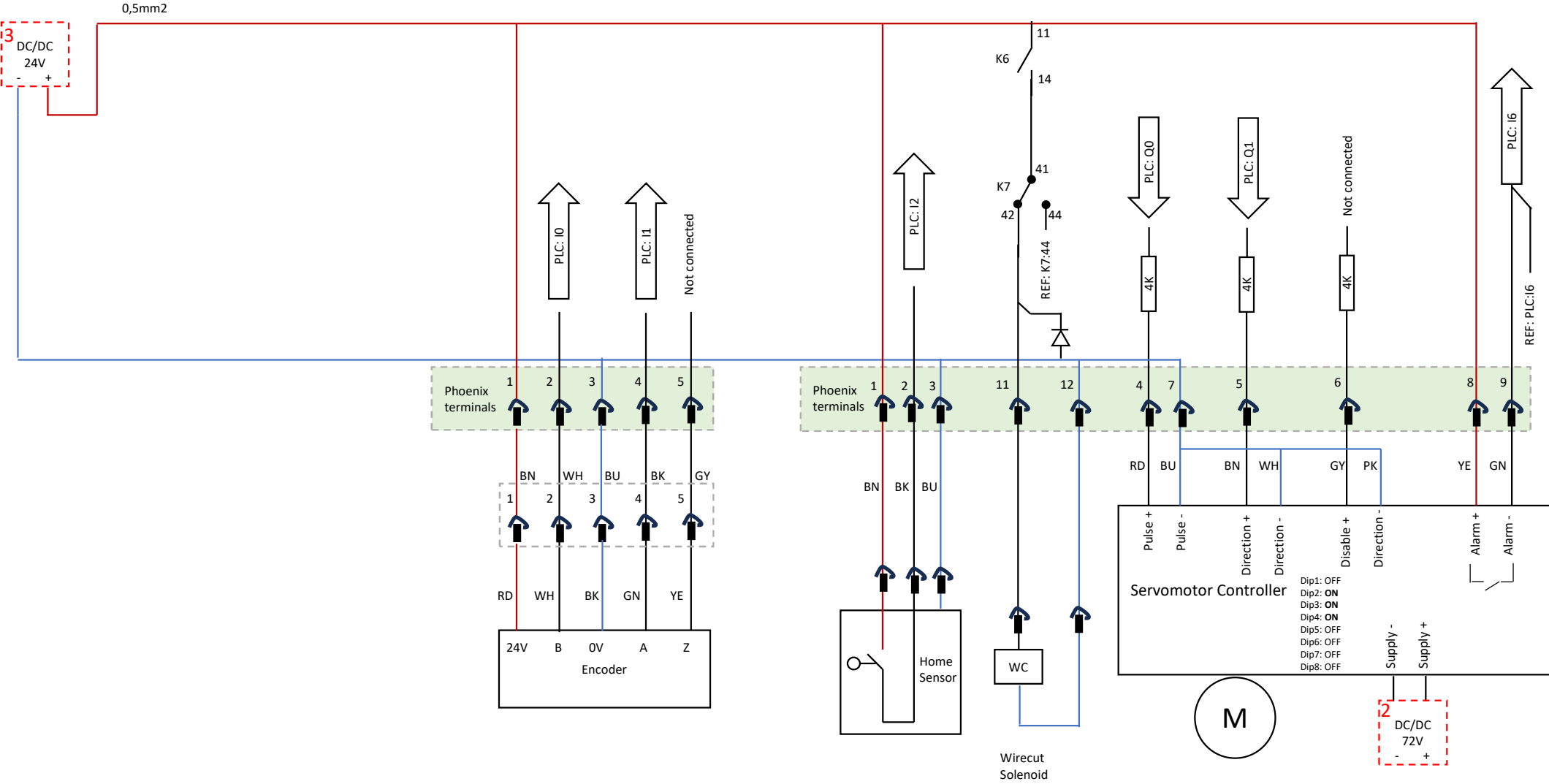

# Servo 2 (Right)

