



DS-673SS

Weighing Scale

Special water-proof technology to be used and quick response to weight change for food factory



Searching for
a New Balance

External Dimensions (mm)

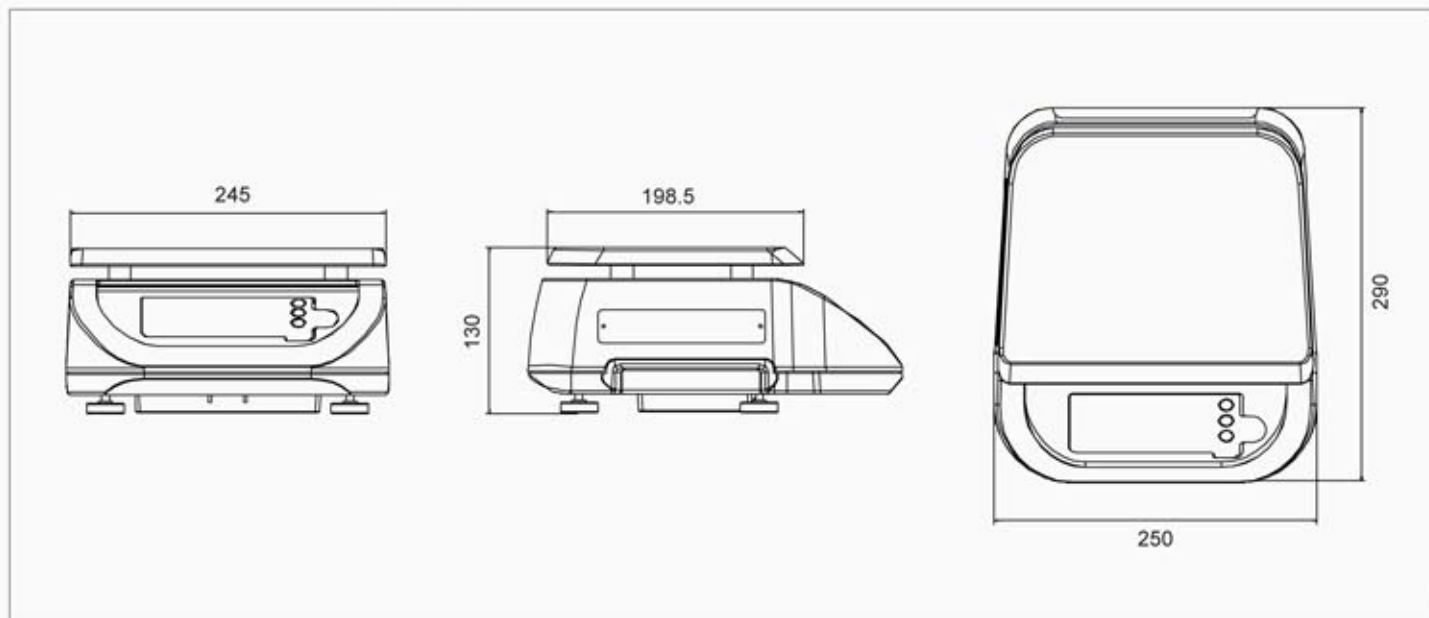

Basic Specifications

Model	DS-673SS			
Capacity	3kg 1g	3kg/6kg 1g/2g	6kg/15kg 2g/5g	15kg/30kg 5g/10g
Display	High brightness LED display Weight Display: 6 digits. Decimal point: Selectable by SPEC			
Dimensions	Platter size : 245(W) x 198.5(D) mm Overall size: 250(W) x 290(D) x 130(H) mm			
Power Source	AC 240/230/220V, 117/100V (Factory Option) DC 6V 5Ah rechargeable battery for 60 hours (option, Fully charged) * Charging condition(AC 240/230/220V, 117/100V, 800mA , 12-14 hours)			
Operating Temperature	-10°C ~ +40°C (OIML)			
Operating Humidity	15% ~ 85% RH			
Power	Intelligent power control, Power Consumption : 18W (AC), 3W (DC)			
Waterproof rating	IP68			

*Rechargeable battery for 60 hours (when dimmer level=2)
*Specifications are subject to change without prior notice.

TERASOKA SEIKO CO., LTD.

13-12 Kugahara 5-chome, Ohta-ku,
Tokyo 146-8580, JAPAN
TEL: +81-3-3752-2131
FAX: +81-3-3752-2801
URL: <http://www.digisystem.com>
E-MAIL: info@hq.digi.co.jp