

# A4MIXT/H-45V C

## HYBRID HANGER FOR DOUBLE THREADED ROD WITH ANGLE CORRECTING SYSTEM

The **A4MIXT/H-45 V C** is a high quality acoustic **HYBRID** hanger. It is devised to provide quality and performance to any given acoustic system. It is used in the installation of acoustic ceiling with galvanized steel channels or similars.

The **A4MIXT/H-45 V C** has in its metal frame double rotatory rivets (**RT-10**) which allows to adjust the angle between both threaded rods. Moreover, it ensures the **HYBRID SYSTEM** compression to be always axial and do not working by torsion which avoid not required deformations of the polymer. In this way, an excellent performance of the elastic system is obtained

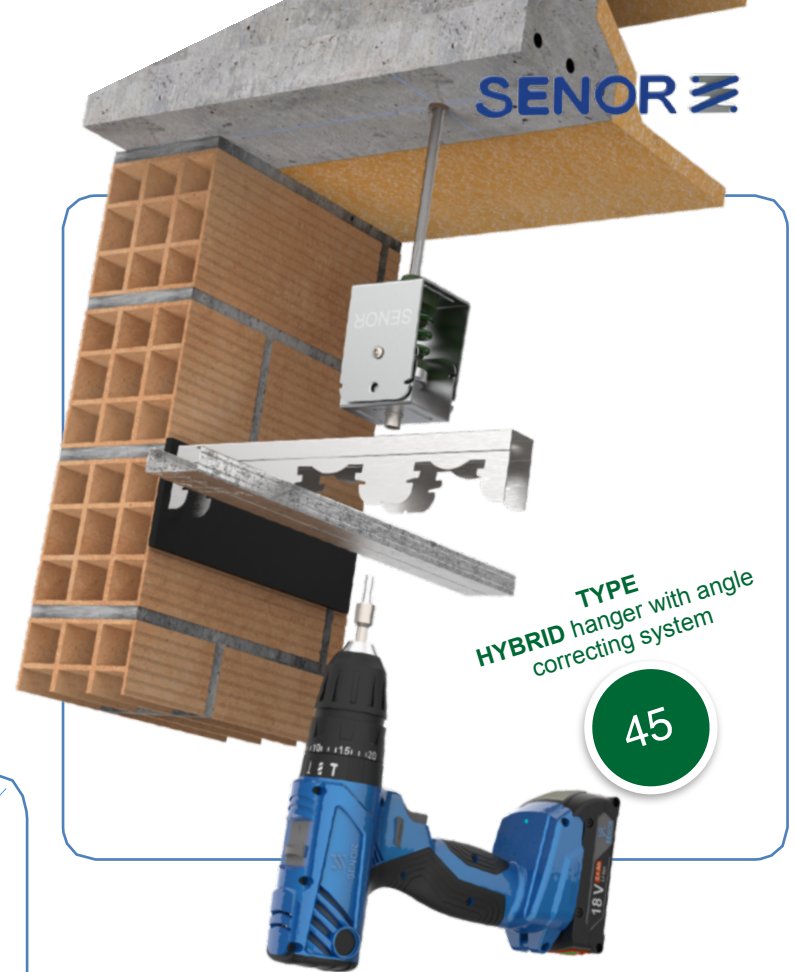

The **HYBRID** system is the combination of a polymer (rubber) and a steel spring:

- The helicoidal spring: it is made of steel according to Standard DIN 2095-UNE EN 10270, with antioxidant finish and covered with metallic **green EPOXY**.
- The polymer: this is a high quality polymer known as **KRAIBURG-TPE** which is tested according to the Standard **UNE-EN ISO 10846-1:2009**.

✓ Resonance frequency: **7-15 Hz**.

This combination provides quality and performance to any given acoustic system and eradicate sound frequencies and vibrations. **We are the only ones who can manufacture it.**

### ANGLE CORRECTING SYSTEM

This model has two locking holes in order to place the piece in the required position and hang acoustic ceilings

REF	COLOUR	METRIC MIN-MAX	CHANNEL (mm)	LOAD (Kg) MIN-MAX	PACKING
SE-A4MIXT/H-45 V C		6 - 8	All types	15 - 45	30

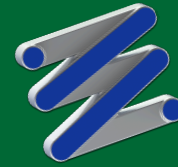

# Ref. SE-A4MIXT/H-45 V C

## Laboratory test UNE-EN ISO 10846-1:2009

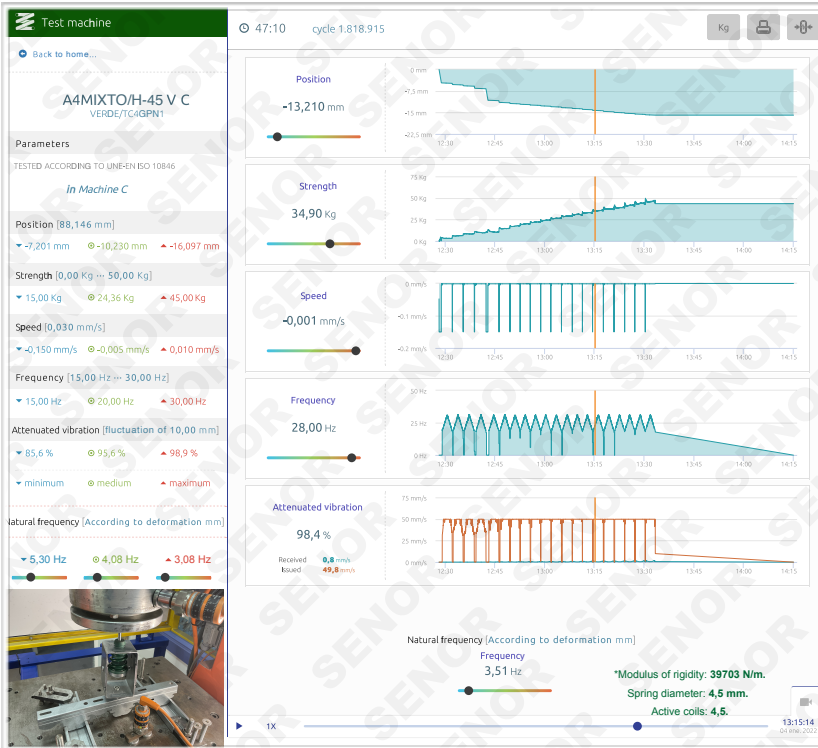

Chart 1

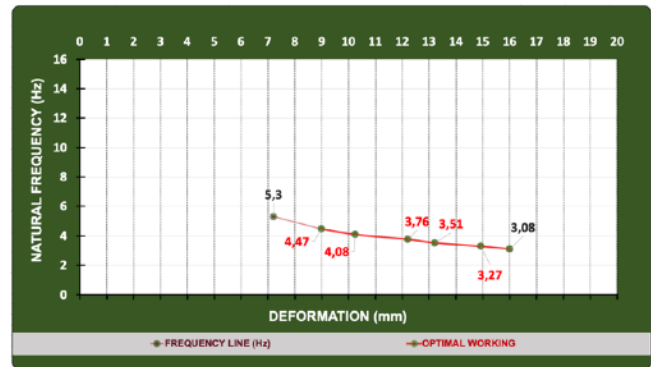
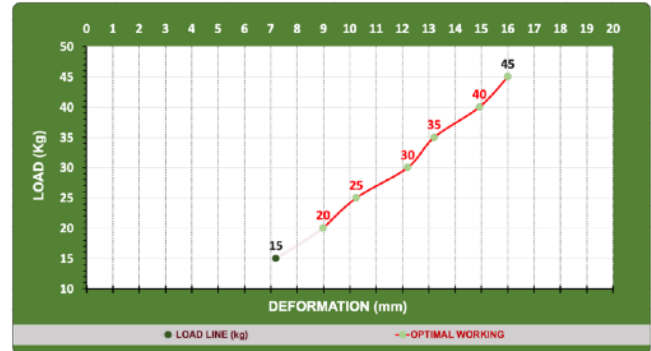

Chart 2

### Results table

LOAD (Kg)	DEFORMATION (mm)	RESONANCE FREQUENCY (Hz)	SWEEP (Hz)		SOUNDPROOFING LEVEL (%)	
20	8,99	4,47	25	50	96,70	99,19
25	10,25	4,08	25	50	97,26	99,33
30	12,20	3,76	25	50	97,69	99,43
35	13,21	3,51	25	50	97,99	99,50
40	14,93	3,27	25	50	98,26	99,57
45	16,00	3,08	25	50	98,46	99,62



### Data sheet

TC4GPN (GP/FG Series)

THERMOLAST® K

#### Product properties

Name TC4GPN

Series GP/FG

Colour / RAL DESIGN Natural

#### Mechanical properties

Hardness 39<sup>+</sup> ± 5<sup>+</sup> ShoreA DIN ISO 7619-1

Density 1,100 g/cm<sup>3</sup> DIN EN ISO 1183-1

Tensile strength<sup>1</sup> 6,5 MPa DIN 53504/ISO 37

Elongation at break<sup>1</sup> 800 % DIN 53504/ISO 37

Tear resistance 14,0 N/mm ISO 34-1 Methode B (b)(Graves)

CS 72 h/23 °C 12 % DIN ISO 815-1 Method A

CS 24 h/70 °C 23 % DIN ISO 815-1 Method A

CS 24 h/100 °C 59 % DIN ISO 815-1 Method A

<sup>1</sup> Deviating from ISO 37 standard test piece S2 is tested with a traverse speed of 200 mm/min.

All values published in this data sheet are rounded average values.



# Ref. SE-A4MIXT/H-45 V C

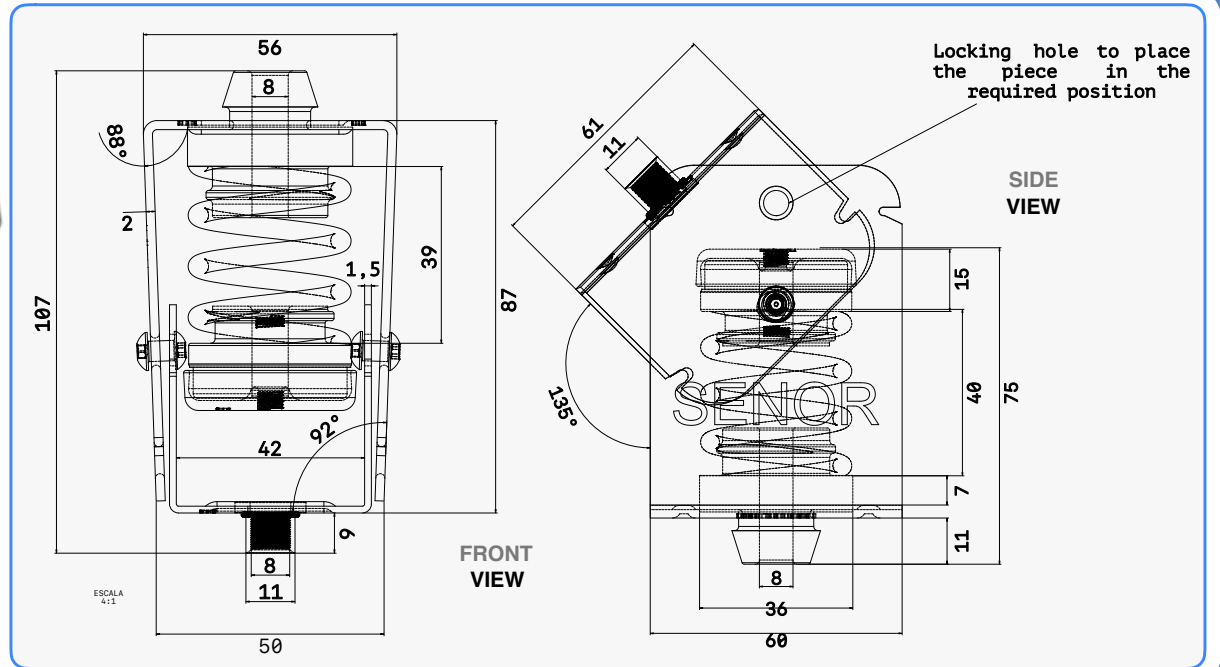

## PLAN VIEW

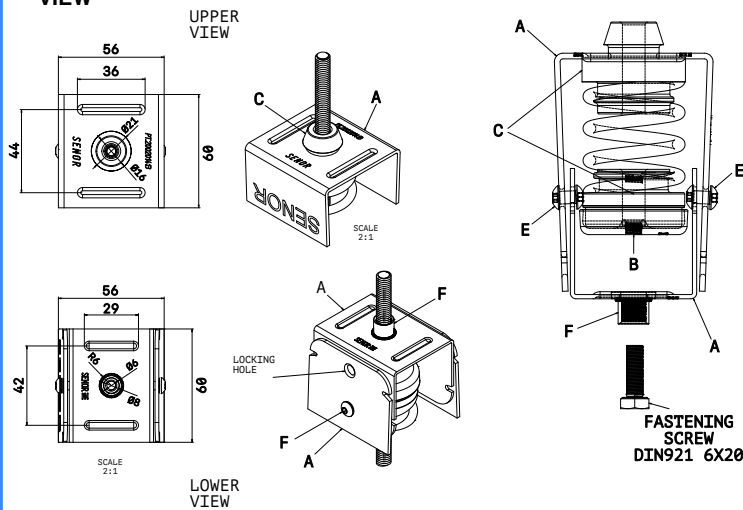

## MATERIALS

This acoustic hanger is composed of:

- **A: Metal frame 2x135** made of galvanized steel according to The Standard **EN 10204/DIN50049/ISO404**.
- **B: Bowl shaped leveller 1,5x41** made of cold rolled steel according to deformation **EN 10204/DIN50049/ISO404**. Transformation according to iron and steel Standard **EN 10346:2009**. Steel quality: **DC03 AM O**. Zinc covering **300 gr/m<sup>2</sup>**.
- **C: The polymer:** the polymer is named **KRAIBURG-TPE/TC4GPN**. Hardness: **39 +/- 5° SHORE A**. Colour: **Green**. Hardness according to **ISO 48-4** o **DIN ISO 7619-1**.
- **E: Rotatory rivets** made of aluminium of 6x8 according to the Standard **UNE-EN ISO15977**.
- **F: Blind rivet nut M8:** Ref. **0371108011 RANURADA/GROOVED 10.9x17**.

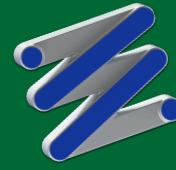

# Ref. SE-A4MIXT/H-45 V C

## ANGLE CORRECTING SYSTEM

This model has two locking holes in order to place the piece in the required position and hang acoustic ceilings

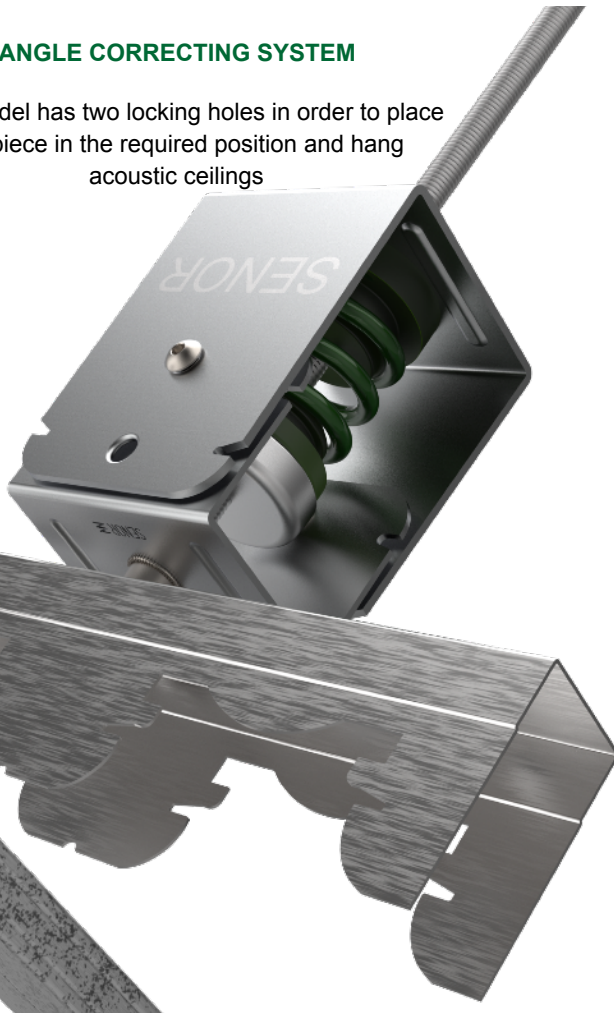

## Note

### POSITION

This acoustic hanger can be placed in tilting position or right



**TYPE**  
HYBRID hanger with angle correcting system

45

 SCAN ME

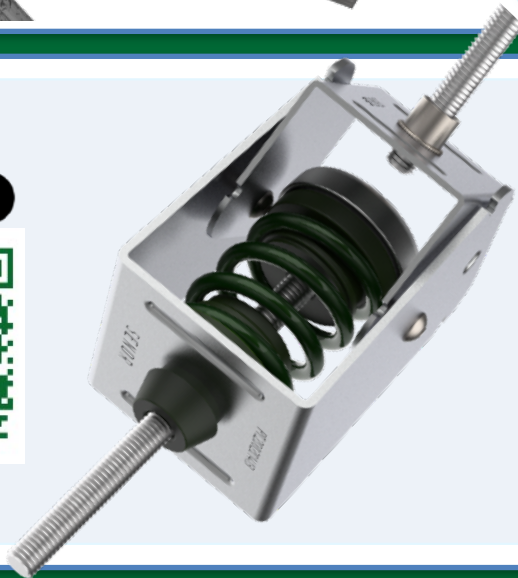

SENOR certifies

## Ref. SE-A4MIXT/H-45 V C

SENOR reserves the right to make changes in specifications at any time without prior notice. It is a responsibility of the user to use the latest and updated version of the product data sheet. A copy of which will be available on request.

**The Standard:** UNE-EN 13964:2016/A1  
**Use:** Installation of acoustic ceilings



# Ref. SE-A4MIXT/H-45 V C

## DEFORMATION AND BREAK TEST

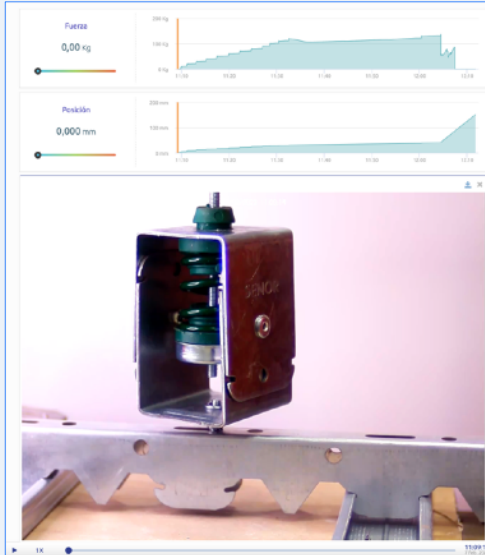

Applied load: 0,00 kg



Applied load: 101,70 kg

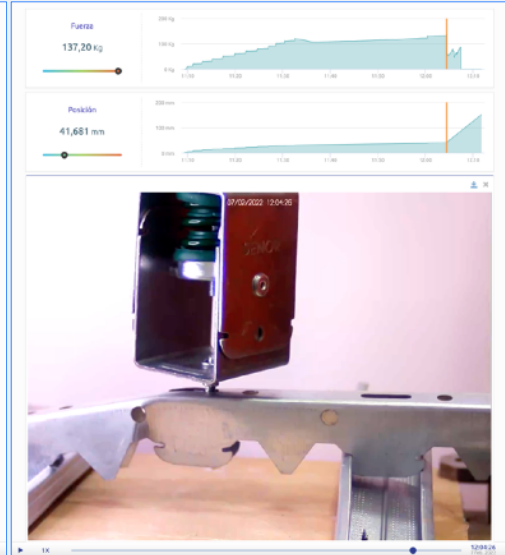

Applied load: 137,20 kg

### Date

SENROR 07 February 2022

### Failure mode

This hanger exceeds the elastic limit of the ceiling channel by reaching **137,20 kg**. In this case, the load line goes down reaching **4,00 kg**.

The burst test is concluded.

### Conclusion

This hanger is designed to bear loads between **15 kg** and **45 kg** (maximum load) It strictly complies with standard UNE-EN 13964:2016/A1. Suspended ceiling. Requirements and test methods. (UNE: Spanish Association for Standardization).



TYPE  
HYBRID hanger with angle  
correcting system

45

