

Product information

Drummotors

**TM 400A50**



*Van der Graaf*  
Power Transmission Equipment

[www.vandergraafpte.nl](http://www.vandergraafpte.nl)



The TM 400's  
playground





# TM 400A50

## A wide range of applications

Van der Graaf has achieved a prominent position on both the domestic and international market with its "GV" Drummotors.

The "GV" Drummotor has found success in a wide range of applications including the following: automotive, X-ray, construction, postal, courier, mining, aggregate, airline baggage, package flow, tyre manufacturing, fish processing, poultry processing, meat processing, agriculture, fruit and vegetable, farming, forestry, baking, dairy and many more.

- 4 Introduction
- 5 Selection table
- 6 Selection table Dahlander motors
- 7 Dimensions Drummotor mild steel
- Dimensions Taildrum mild steel
- 8 Dimensions bracket / Cable exit
- 9 Cross sectional / parts description
- 12 Options
- 15 Product range
- 16 Contact us



## Selection table

TYPE TM 400A50	Power kW	Beltspeed m/s at 50 Hz						Min. L mm Design A	Min. L mm Design B	Full load curr. 400 V - 50 Hz I = ... A	Weight kg L=600				
		Beltpull N													
215 215 Z 215 ZV	11,0	<b>4,80</b> 2175 <b>3,40</b> 3075 <b>2,00</b> 5225	<b>4,20</b> 2490 <b>3,20</b> 3265	<b>3,60</b> 2905 <b>3,00</b> 3485	<b>2,60</b> 4020	<b>2,40</b> 4355		600	650	19,7	243				
410 410 Z 410 ZV	7,5	<b>4,30</b> 1655 <b>1,70</b> 4190 <b>1,30</b> 5480	<b>3,90</b> 1825 <b>1,60</b> 4455	<b>3,50</b> 2035 <b>1,50</b> 4750	<b>3,10</b> 2300	<b>2,80</b> 2545	<b>2,40</b> 2970	<b>2,10</b> 3395	<b>1,80</b> 3960		600	650	15,0	243	
475 475 Z 475 ZV	5,5	<b>4,30</b> 1215 <b>1,70</b> 3075 <b>1,00</b> 5225	<b>3,90</b> 1340 <b>1,60</b> 3265	<b>3,50</b> 1495 <b>1,50</b> 3485	<b>3,10</b> 1685 <b>1,30</b> 4020	<b>2,80</b> 1865 <b>1,20</b> 4355	<b>2,40</b> 2175	<b>2,10</b> 2490	<b>1,80</b> 2905		600	600	10,5	238	
455 455 Z 455 ZV	4,0	<b>4,30</b> 885 <b>1,30</b> 2925 <b>1,00</b> 3800 <b>0,70</b> 5430	<b>3,90</b> 975 <b>1,10</b> 3455 <b>0,90</b> 4220	<b>3,50</b> 1085 <b>0,85</b> 4470	<b>3,10</b> 1225 <b>0,80</b> 4750	<b>2,80</b> 1355	<b>2,40</b> 1585	<b>2,10</b> 1810	<b>1,90</b> 2000	<b>1,70</b> 2235	<b>1,50</b> 2535	600	600	7,8	233
440 440 Z	3,0	<b>2,80</b> 1020 <b>0,90</b> 3165	<b>2,40</b> 1190 <b>0,80</b> 3565	<b>2,10</b> 1355 <b>0,70</b> 4070	<b>1,90</b> 1500 <b>0,65</b> 4385	<b>1,70</b> 1675	<b>1,50</b> 1900	<b>1,30</b> 2190	<b>1,20</b> 2375	<b>1,00</b> 2850	600	600	6,6	233	
640 640 Z 640 ZV	3,0	<b>3,50</b> 815 <b>0,60</b> 4750 <b>0,50</b> 5700	<b>1,60</b> 1780	<b>1,40</b> 2035	<b>1,10</b> 2590							600	600	7,1	233
630 630 Z 630 ZV	2,2	<b>1,90</b> 1100 <b>0,60</b> 3485 <b>0,40</b> 5225	<b>1,60</b> 1305 <b>0,50</b> 4180	<b>1,40</b> 1495 <b>0,45</b> 4645	<b>1,10</b> 1900	<b>1,00</b> 2090	<b>0,85</b> 2460	<b>0,75</b> 2785	<b>0,65</b> 3215		600	600	4,9	233	
820 820 Z	1,5	<b>1,40</b> 1020 <b>0,45</b> 3165	<b>1,20</b> 1190 <b>0,40</b> 3565	<b>1,10</b> 1295 <b>0,36</b> 3960	<b>0,80</b> 1780 <b>0,32</b> 4455	<b>0,75</b> 1900	<b>0,65</b> 2190	<b>0,60</b> 2375	<b>0,50</b> 2850		600	600	4,6	233	
1220 1220 Z 1220 ZV	1,5	<b>0,90</b> 1585 <b>0,30</b> 4750 <b>0,26</b> 5480	<b>0,70</b> 2035								600	600	5,8	238	
815 815 Z	1,1	<b>1,40</b> 745 <b>0,45</b> 2320	<b>1,20</b> 870 <b>0,40</b> 2615	<b>1,10</b> 950 <b>0,36</b> 2905	<b>0,80</b> 1305 <b>0,32</b> 3265	<b>0,75</b> 1395	<b>0,65</b> 1610	<b>0,60</b> 1740	<b>0,50</b> 2090		600	600	3,3	233	
1215 1215 Z 1215 ZV	1,1	<b>0,90</b> 1160 <b>0,30</b> 3485 <b>0,20</b> 5225	<b>0,70</b> 1495 <b>0,26</b> 4020	<b>0,24</b> 4355							600	600	5,9	233	

Available standard facewidth's: 600 - 650 - 700 - 750 - 800 - 850 - 900 - 950 - 1000 - 1050 - 1100 - 1150 mm

When an electro-mechanical brake is fitted, the minimum facewidth is increased by 150 mm

When a backstop is fitted in a 2-pole Drummotor, the minimum facewidth is increased by 50 mm

The total weight of a Drummotor grows approx. 12,5 kg. per 100 mm

Available torque: (Beltpull N x drum diameter m) / 2 Nm

## Selection table Dahlander motors

TYPE TM 400A50	Power kW	Beltspeed m/s at 50 Hz							Min. L mm Design A	Min. L mm Design B	Full load curr. 400 V - 50 Hz I = ... A	Weight kg L=600	
		Beltpull N											
<b>470/210</b> <b>470/210 Z</b>	<b>5,0/7,5</b>	<b>2,40/4,80</b> 1980/1485 <b>1,70/3,40</b> 2795/2095	<b>2,10/4,20</b> 2260/1695 <b>1,60/3,20</b> 2970/2225	<b>1,80/3,60</b> 2640/1980 <b>1,50/3,00</b> 3165/2375	<b>1,30/2,60</b> 3655/2740	<b>1,20/2,40</b> 3960/2970	<b>1,00/2,00</b> 4750/3565		600	650	10,6/15,2	243	
<b>455/275</b> <b>455/275 Z</b> <b>455/275 ZV</b>	<b>4,0/5,5</b>	<b>2,40/4,80</b> 1585/1090 <b>1,00/2,00</b> 3800/2615 <b>0,70/1,40</b> 5430/3730	<b>2,10/4,20</b> 1810/1245 <b>0,90/1,80</b> 4220/2905	<b>1,90/3,80</b> 2000/1375 <b>0,85/1,70</b> 4470/3075	<b>1,70/3,40</b> 2235/1535 <b>0,80/1,60</b> 4750/3265	<b>1,50/3,00</b> 2535/1740	<b>1,30/2,60</b> 2925/2010	<b>1,10/2,20</b> 3455/2375	600	600	7,8/10,9	238	
<b>440/255</b> <b>440/255 Z</b>	<b>3,0/4,0</b>	<b>2,40/4,80</b> 1190/790 <b>0,90/1,80</b> 3165/2110	<b>2,10/4,20</b> 1355/905 <b>0,85/1,70</b> 3355/2235	<b>1,90/3,80</b> 1500/1000 <b>0,80/1,60</b> 3565/2375	<b>1,70/3,40</b> 1675/1120 <b>0,70/1,40</b> 4070/2715	<b>1,50/3,00</b> 1900/1265 <b>0,65/1,30</b> 4385/2925	<b>1,30/2,60</b> 2190/1460	<b>1,10/2,20</b> 2590/1725	<b>1,00/2,00</b> 2850/1900	600	600	5,8/7,1	233
<b>830/440</b> <b>830/440 ZV</b>	<b>2,2/3,0</b>	<b>1,40/2,80</b> 1495/1020 <b>0,43/0,86</b> 4920/3355 <b>0,40/0,80</b> 5225/3565	<b>1,20/2,40</b> 1740/1190	<b>1,05/2,10</b> 1990/1355	<b>0,95/1,90</b> 2200/1500	<b>0,85/1,70</b> 2460/1675	<b>0,75/1,50</b> 2785/1900	<b>0,50/1,00</b> 4180/2850	<b>0,45/0,90</b> 4645/3165	600	600	7,7/5,9	238
<b>820/430</b> <b>820/430 Z</b>	<b>1,5/2,2</b>	<b>2,15/4,30</b> 665/485 <b>0,85/1,70</b> 1675/1230 <b>0,45/0,90</b> 3165/2320	<b>1,95/3,90</b> 730/535 <b>0,75/1,50</b> 1900/1395 <b>0,43/0,85</b> 3355/2460	<b>1,75/3,50</b> 815/595 <b>0,65/1,30</b> 2190/1610 <b>0,40/0,80</b> 3565/2615	<b>1,55/3,10</b> 920/675 <b>0,55/1,10</b> 2590/1900 <b>0,35/0,70</b> 4070/2985	<b>1,40/2,80</b> 1020/745 <b>0,50/1,00</b> 2850/2090 <b>0,33/0,65</b> 4385/3215	<b>1,20/2,40</b> 1190/870	<b>1,05/2,10</b> 1355/995	<b>0,95/1,90</b> 1500/1100	600	600	5,8/4,7	233

Available standard facewidth's: 600 - 650 - 700 - 750 - 800 - 850 - 900 - 950 - 1000 - 1050 - 1100 - 1150 mm

When an electro-mechanical brake is fitted, the minimum facewidth is increased by 150 mm

When a backstop is fitted in a 2-pole Drummotor, the minimum facewidth is increased by 50 mm

The total weight of a Drummotor grows approx. 12,5 kg. per 100 mm

Available torque: (Beltpull N x drum diameter m) / 2 Nm



## Dimensions

### TM 400A50

TM 400A50, mild steel Drummotor with cast iron junctionbox

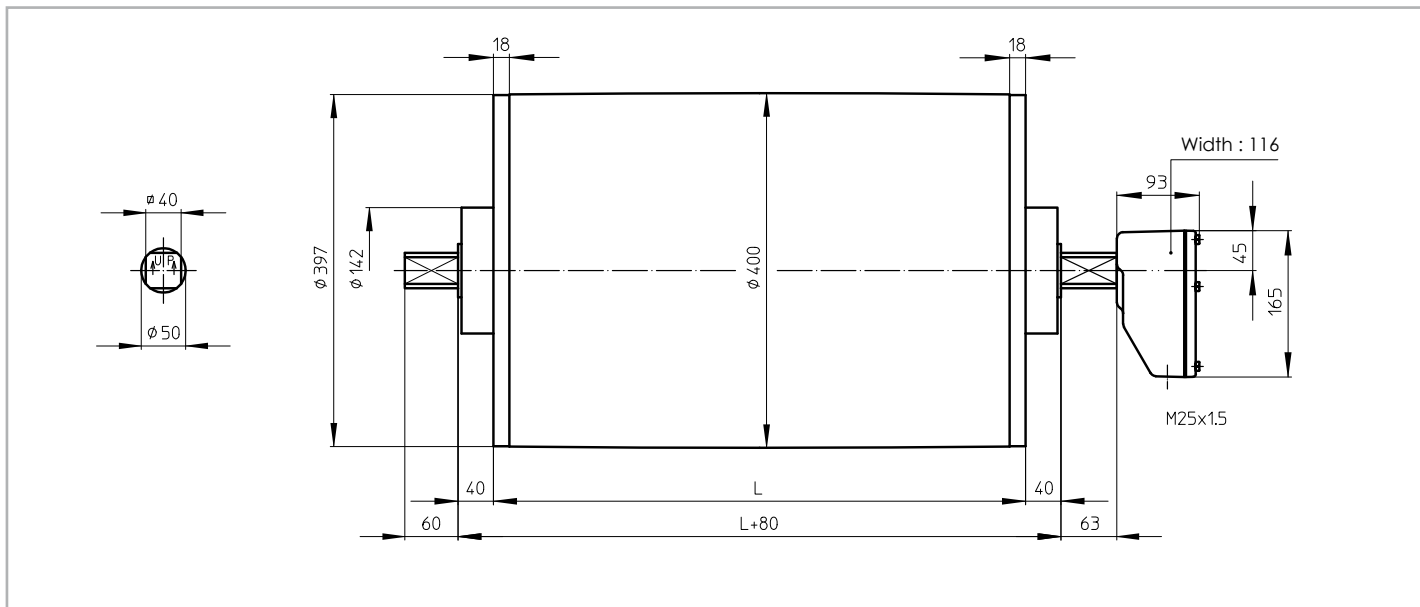

### KT 400A50

KT 400A50, mild steel Taildrum

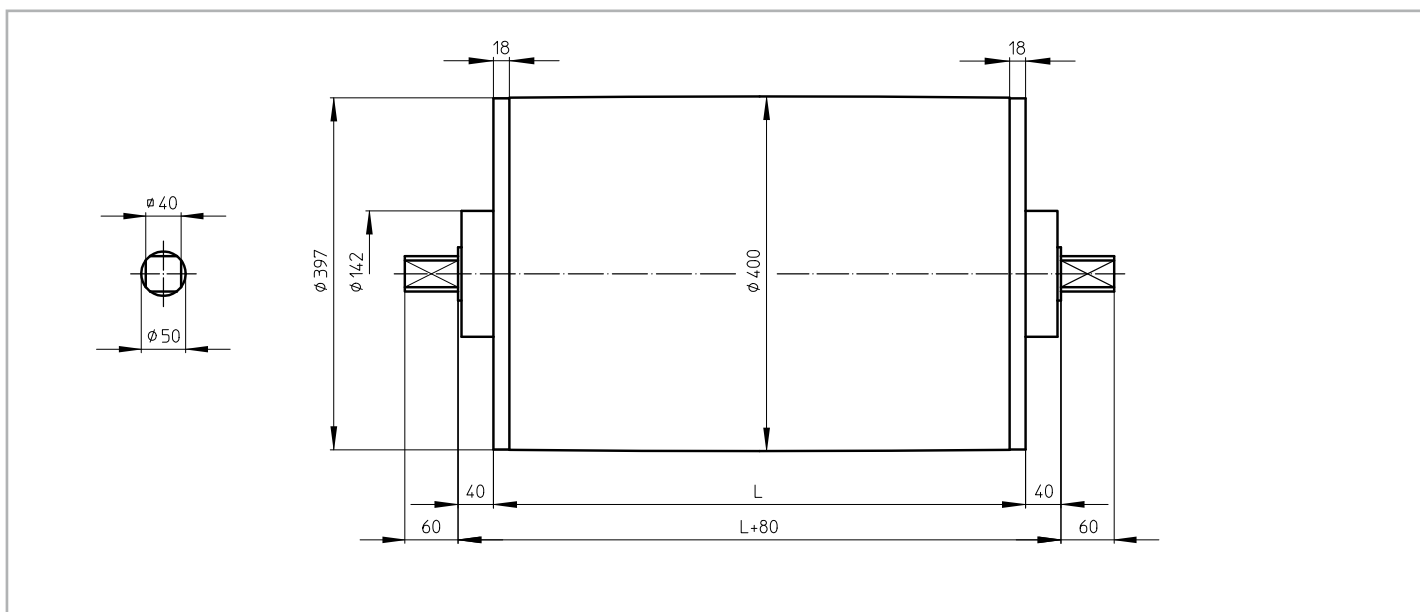

# Dimensions bracket / Cable exit

## AB 50

AB 50, cast iron or stainless steel bracket  
Weight: 7,2 kg per pair

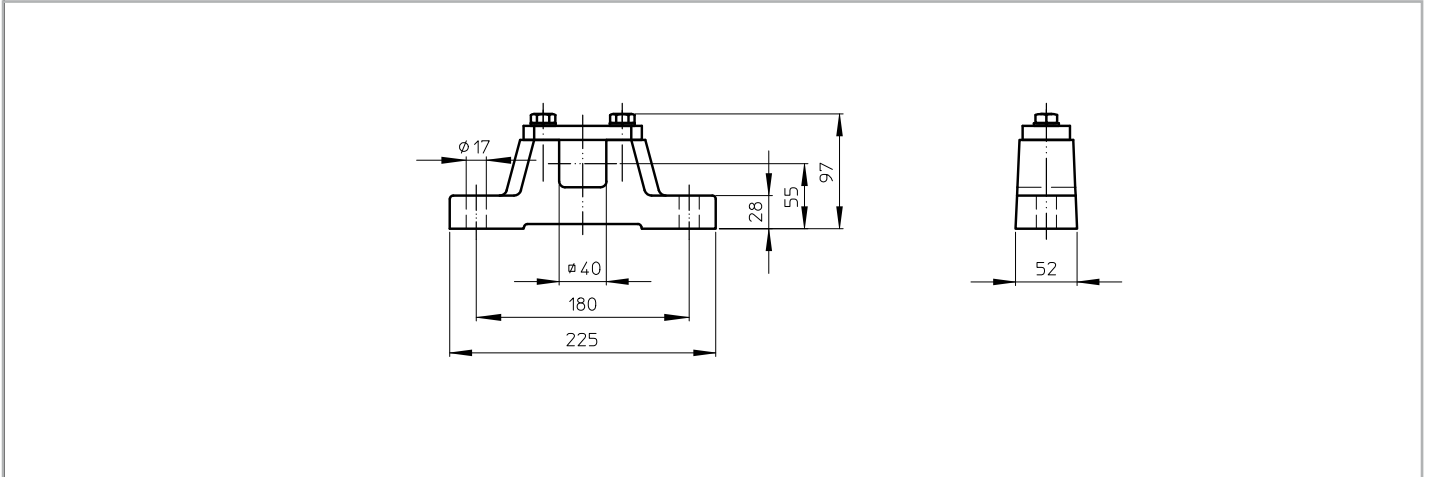

Standard design of a TM 400A50 is with a cast iron junctionbox. For stainless steel design, this can be either a PU coated cast iron or stainless steel junctionbox.

On request a drum motor can be fitted with a cable. In this case it is important to know the available voltage (preferably 1 voltage), the length of the cable, whether the cable is shielded or not and the type of cable exit.

An overview of available cable exits is shown below.

### Option 1

Straight cable exit with cable gland

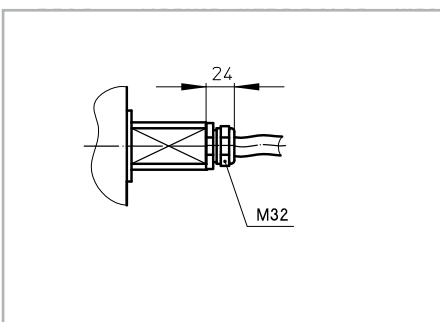

### Option 3

Elbow cable exit with cable gland  
(minimum facewidth increases with 50 mm)

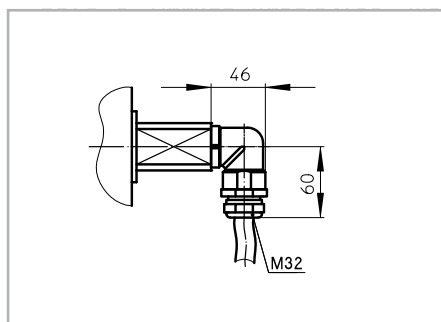





TM 400A50

Legenda

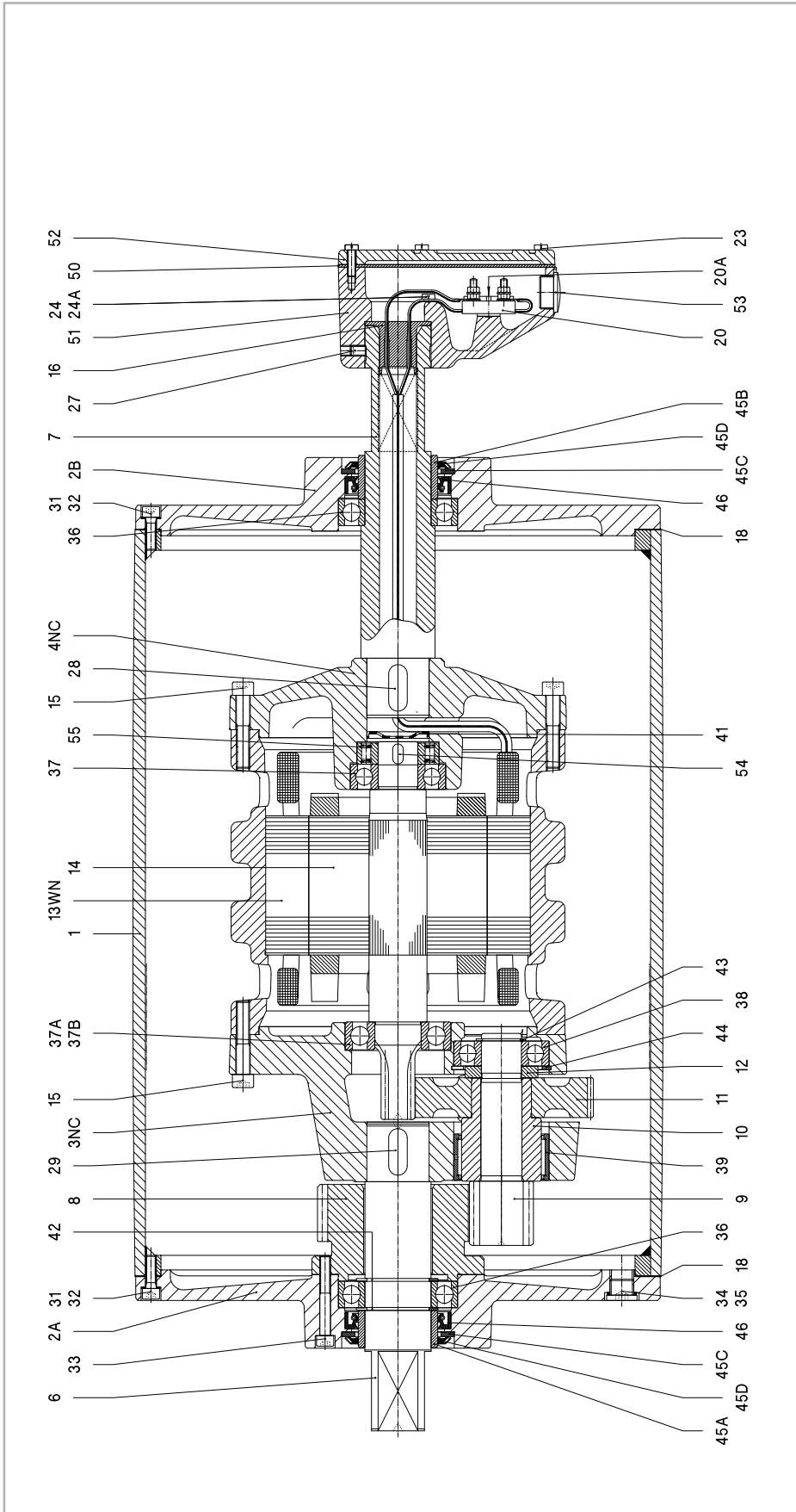

1	Shell	13WN	Stator	29	Key	39	Needlebearing	51	Junctionbox
2A	Endflange	14	Rotor	31	Int. hex screw	41	Disc	52	Junctionbox cover
2B	Endflange	15	Int. hex screw	32	Washer	42	Circlip	53	Stopping plug
3NC	Gearhousing	16	Cable passage	33	Int. hex screw	43	Circlip	54	Key
4NC	Motoflange	18	Gasket	34	Fillerplug	44	Circlip	55	Backstop
6	Shaftend	20	Terminalboard	35	Washer	45A	Bearing race	57	Dataplate
7	Hollow shaft	20A	Cyl. head screw	36	Ballbearing	45B	Bearing race		
8	External gear	23	Cyl. head screw	37	Ballbearing	45C	Shim plated		
9/10	Pinion with bush	24	Cyl. head screw	37A	Ballbearing	45D	Gammaring		
11	Gear	24A	Toothed lock washer	37B	Ballbearing	46	Olised		
12	Distance ring	27	Setscrew	38	Ballbearing	50	Seal		

# Cross sectional / parts description

TM 400A50 Z

Legenda

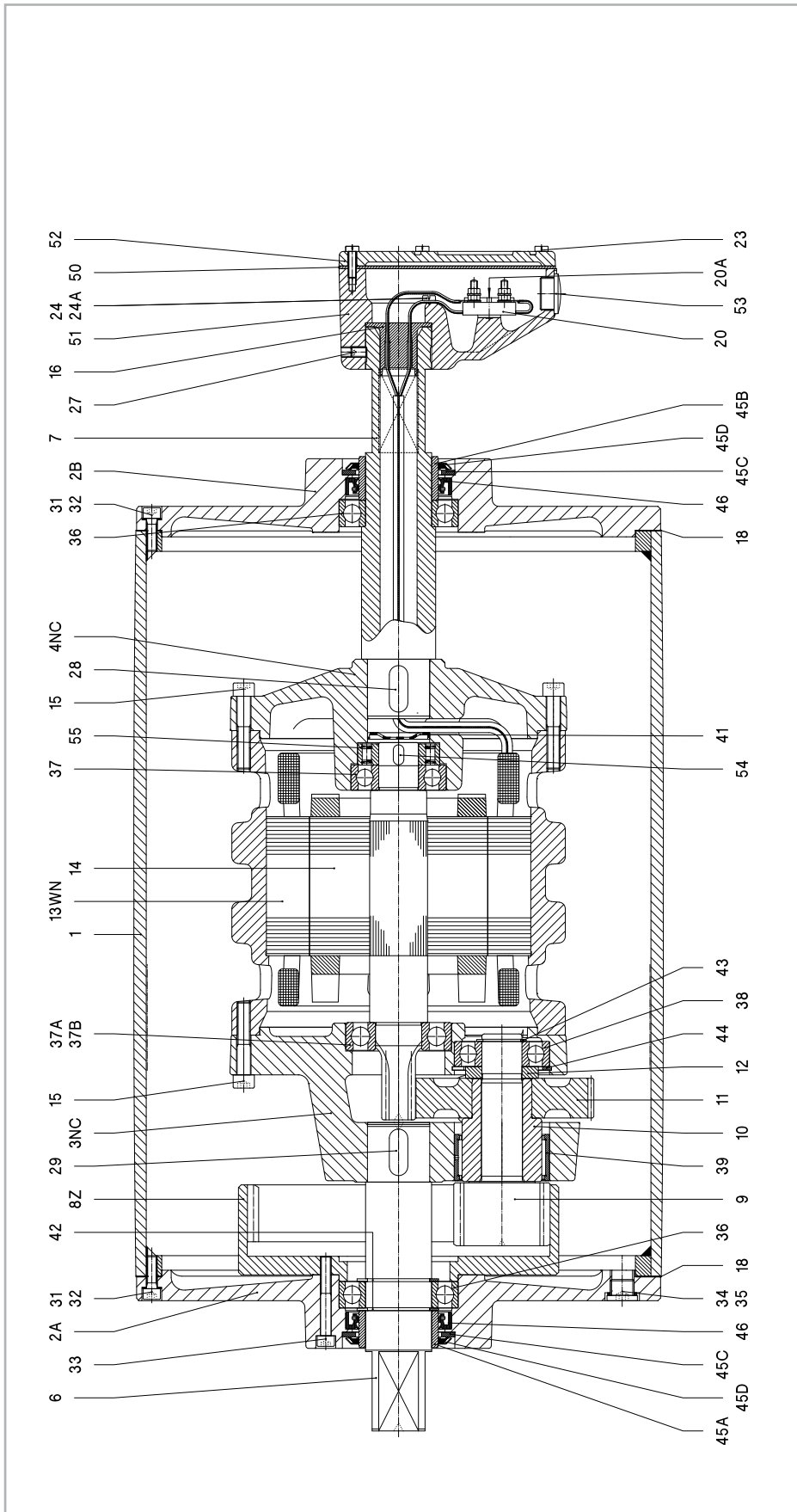

1	Shell	29	Key	38	Ballbearing	50	Seal
2A	Endflange	31	Int. hex screw	39	Needlebearing	51	Junctionbox
2B	Endflange	32	Washer	41	Disc	52	Junctionbox cover
3NC	Gearhousing	33	Int. hex screw	42	Circlip	53	Stopping plug
4NC	Motoflange	34	Fillerplug	43	Circlip	54	Key
6	Shaftend	35	Washer	44	Circlip	55	Backstop
7	Hollow shaft	36	Ballbearing	45A	Bearing race	57	Dataplate
8Z	Internal gear	36V	Cyl. roller bearing	45B	Bearing race		
9/10	Pinion with bush	37	Ballbearing	45C	Shim plated		
11	Gear	37A	Ballbearing	45D	Gammaring		
12	Distance ring	37B	Ballbearing	46	Olised		



# Cross sectional / parts description

KT 400A50

Legenda

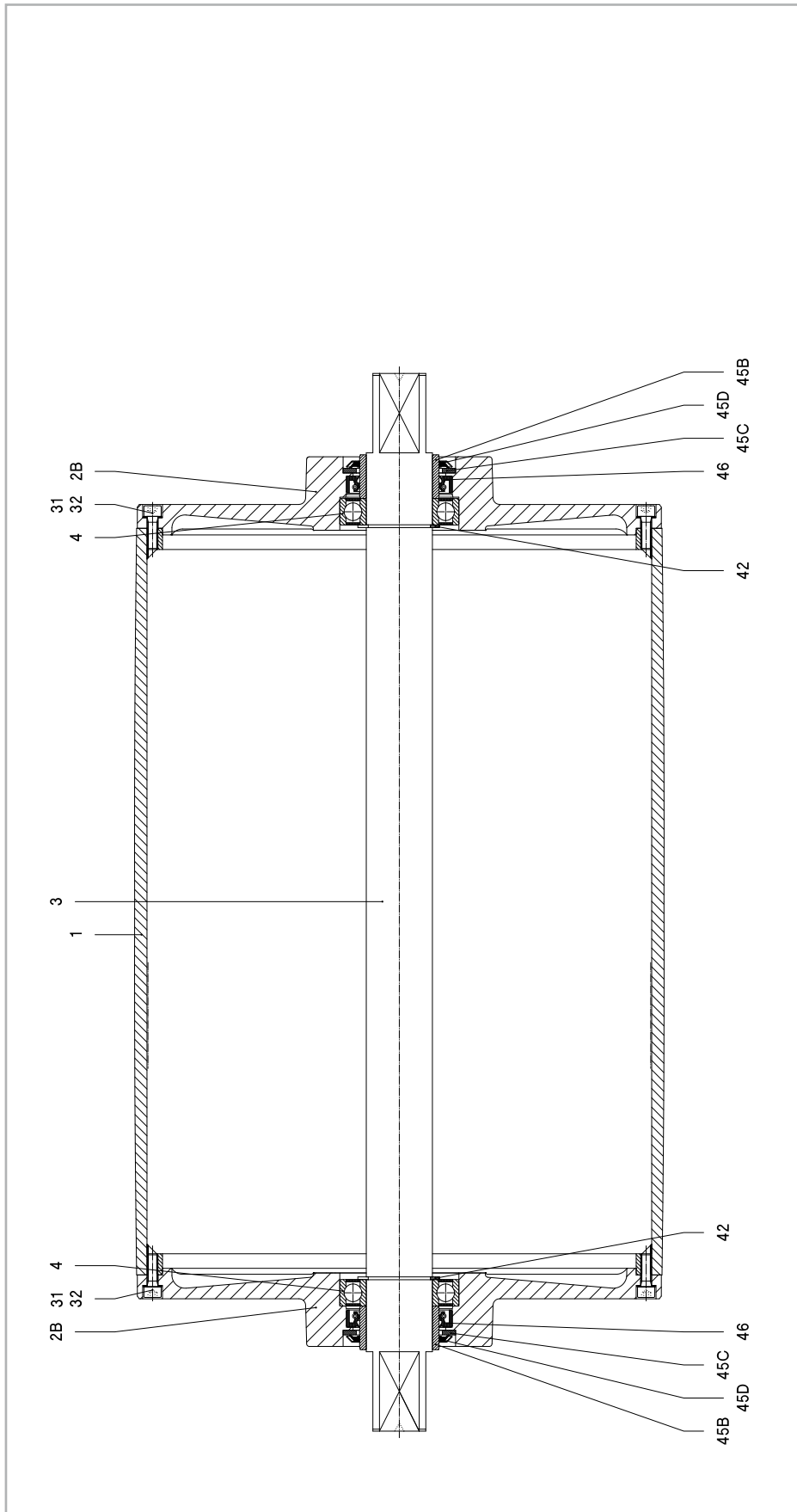

- |    |                |     |              |
|----|----------------|-----|--------------|
| 1  | Shell          | 42  | Circlip      |
| 2B | Endflange      | 45B | Bearing race |
| 3  | Shaft          | 45C | Shim plated  |
| 4  | Ballbearing    | 45D | Gammaring    |
| 31 | Int. hex screw | 46  | Oilseal      |
| 32 | Washer         |     |              |

## Material

The external parts of the Drummotor are made from mild steel and cast iron. Depending on the application it is also possible to manufacture in stainless steel (complete or part). You can choose between stainless steel 304 (general food industry) and stainless steel 316 (salt water applications).

## Backstop - Brake

If an inclined belt conveyor is stopped fully loaded, it could run backwards.

To prevent this we can install a backstop. One of the bearings in the Drummotor is replaced by a one way bearing. The way this bearing is installed determines the direction of rotation of the drum. TBRH indicates a cw rotation and TBLH ccw.

In situations where a Drummotor needs to be able to drive in both directions it is not possible to use a backstop. In this case we use a brake. When an declined belt or a horizontal belt needs to be stopped quickly to pick or place items a brake is the best solution.

## Inclined position

Sometimes a Drummotor needs to be installed on an inclined or even vertical position. This is possible, but we need to make adjustments to the oil level in the drum as the oil will flow to the lower side of the Drummotor causing the top bearing to run without lubrication. To prevent problems we will need to know the installation angle so we can fill the drum with extra oil and fit a double sealed bearing on the upper side.

## Thermal protection

A Van der Graaf Drummotor can be fitted with thermal protection. This consists of either a thermistor (PTC) or bi-metal (klixon). We install these on each phase of the electric motor.

## Encoder - Sensor bearing

In certain applications it is required to measure the speed or position of a conveyor belt. For this type of application we can install an encoder or sensor bearing to accurately measure rotational speed of the Drummotor.

The accuracy needed will determine the type of encoder or sensor used.

## Lagging

The power produced by the Drummotor has to be transferred to the belt and lagging is used to give more friction between the Drummotor and the conveyor belt. Van der Graaf can fit your Drummotor with different kinds of lagging.

There is a difference between cold and hot vulcanised lagging. Cold vulcanised means the lagging is glued to the Drummotor usually in sheet form and the join 'welded' together. Hot vulcanising is a process where the shell is wrapped around with thin layers of rubber. The shell with the rubber is then baked in an autoclave fusing the layers together creating a seamless finish.

It is possible to cut grooves (e.g chevron or diamond) in the lagging.

## Sprockets

Do you wish to use a Drummotor to drive modular belts? Van der Graaf can help you! Fitting sprockets suitable for various types of modular belts is a simple solution. The Drummotor is manufactured with a cylindrical shell and machined with a patented 'keying' system. The sprockets are simply 'slid' on and locked securely into position.

## Sealings for mild steel Drummotors

RB sealing - IP 66



This is Van der Graaf's standard sealing. This type of sealing will work in most conditions.

RBS sealing - IP 66



This sealing is specifically designed for those applications where high water pressure is used for cleaning.

HD sealing - IP 66



This sealing is designed for abrasive applications, like sand, gravel and soil.

## Sealings for stainless steel Drummotors

CR sealing - IP 66



This is our standard sealing for stainless steel Drummotors, a very effective, multi labyrinth sealing.

UW sealing - IP 68



This sealing is suitable for under water applications. The maximum depth is approx 2,5 m.

# Options

Specification	Standard	Optional
<b>Construction</b>		
Shafts and bolts	Mild steel	Stainless steel
Endflanges	Cast iron	Stainless steel
Shell	Mild steel	Stainless steel
Junctionbox	Cast iron	PU coated cast iron or stainless steel
Cable		Shielded or non-shielded
Sealing mild steel	RB	RBS, HD
Sealing stainless steel	CR	UW
<b>Shell</b>		
Crowned	•	
Cylindrical		•
Balanced		•
Lagging, cold vulcanised		•
Lagging, hot vulcanised		•
Lagging, FDA approved		•
Fitted with grooves, patterns		•
Sprockets		•
<b>Electro motor</b>		
Three-phase asynchronous	•	
Power supply (P < 3 kW)	230/400 V - 50 Hz	Other voltages and frequencies on request
Power supply (P ≥ 3 kW)	400/690 V - 50 Hz	Other voltages and frequencies on request
Two speed (Dahlander)		•
Insulation class	F	H
Thermal protection		Bi-metal or thermistor
Run by frequency inverter	•	
<b>Other options</b>		
Food grade oil		•
Backstop, mechanical		•
Brake, electro mechanical		•
Clutch brake, electro mechanical		•
Inclined or vertical position		•
Other facewidth's		•
Different shaft designs		•
Encoder or sensor bearing in Drummotor		•
Encoder or sensor bearing in Taildrum		•
<b>Certificates</b>		
CE	•	
UL		•
CSA		•
ATEX zone 22, dust		•



## Product range

### Our products, an overview

Drum motor type	TM 100B25	TM 113B25	TM 127.25	TM 138.25	TM 160.25	TM 160.30	TM 215.30	TM 215.40
Drum diameter (mm)	100	113	127	138	160	160	215	215
Shaft diameter (mm)	25	25	25	25	25	30	30	40
Power (kW)	0.05-0.37	0.04-0.55	0.10-1.1	0.10-1.1	0.10-0.75	0.10-2.2	0.10-2.2	0.37-5.5
Speed (m/s)	0.007-3.60	0.008-4.40	0.008-2.60	0.009-2.80	0.13-3.30	0.06-4.00	0.08-5.30	0.12-4.70

Drum motor type	TM 215B50	TM 273.40	TM 315.40	TM 315.50	TM 400A50	TM 400.60	TM 500A60	TM 500A75
Drum diameter (mm)	215	273	315	315	400	400	500	500
Shaft diameter (mm)	50	40	40	50	50	60	60	75
Power (kW)	1.5-4.0	0.37-5.5	0.37-5.5	1.1-11	1.1-11	1.5-22	1.5-22	11-30
Speed (m/s)	0.18-0.31	0.17-5.00	0.18-5.20	0.16-4.40	0.20-4.80	0.20-4.60	0.25-4.70	0.80-3.20

Drum motor type	TM 620A75	TM 630A100	TM 800A100	TM 800A130
Drum diameter (mm)	620	630	800	800
Shaft diameter (mm)	75	100	100	130
Power (kW)	11-30	22-55	22-55	55-132
Speed (m/s)	1.00-3.90	1.00-4.00	1.25-5.10	1.60-4.50

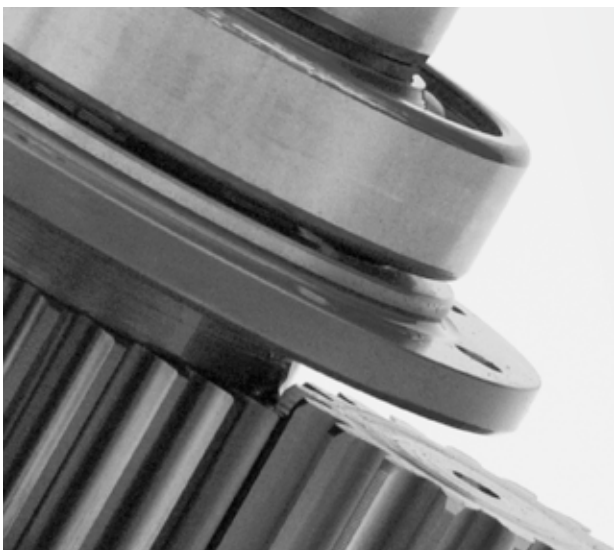

#### Design benefits

- Robust, industrial design
- Fully enclosed
- Oil filled
- Well-sized gears and bearings

#### Installation advantages

- Easy to install
- Compact and reliable
- Easy to clean
- Virtually maintenance free
- Low Life Cycle Costs





# Van der Graaf

## Power Transmission Equipment

### Contact us

#### Netherlands

Van der Graaf B.V.  
De Weijert 14  
P.O. Box 3  
8325 ZG Vollenhove  
Tel: 00 31 527 241441  
Fax: 00 31 527 241488  
E-mail: [info@vandergraafpte.nl](mailto:info@vandergraafpte.nl)  
[www.vandergraafpte.nl](http://www.vandergraafpte.nl)



#### Canada

Van der Graaf Inc.  
2 Van der Graaf Court  
Brampton  
Ontario L6T 5R6  
Tel: 00 1 905 793 8100  
Fax: 00 1 905 793 812  
E-mail: [info@vandergraaf.com](mailto:info@vandergraaf.com)  
[www.vandergraaf.com](http://www.vandergraaf.com)



#### Great Britain

Van der Graaf U.K. Ltd.  
Unit 23, The Metro Centre  
Welbeck Way Woodston  
Peterborough PE2 7UH  
Tel: 00 44 1733 391777  
Fax: 00 44 1733 391044  
E-mail: [sales@vandergraaf.co.uk](mailto:sales@vandergraaf.co.uk)  
[www.drummy.com](http://www.drummy.com)



#### USA

Van der Graaf Corp.  
51515 Celeste  
Shelby Township  
48315 Michigan  
Tel: 00 1 866 595 3292  
Fax: 00 1 888 326 0089



#### Germany

Van der Graaf GmbH  
Rheiner Straße 24 B  
48432 Rheine-Mesum  
Tel: 00 49 5975 306210  
Fax: 00 49 5975 3062120  
E-mail: [info@vandergraaf.de](mailto:info@vandergraaf.de)  
[www.vandergraaf.de](http://www.vandergraaf.de)



#### Sweden

Van der Graaf Scandinavia AB  
Spinngatan 2  
267 73 Billesholm  
Tel: 00 46 42 22 0802  
Fax: 00 46 42 22 0803  
E-mail: [info@vandergraaf.se](mailto:info@vandergraaf.se)  
[www.vandergraaf.se](http://www.vandergraaf.se)



#### Finland

Van der Graaf Scandinavia AB  
Tel: 00 358 400 419063  
E-mail: [info@vandergraaf.fi](mailto:info@vandergraaf.fi)  
[www.vandergraaf.fi](http://www.vandergraaf.fi)