

# HYGIENIC DESIGN



## FEATURES

- HIGH PRESSURE CLEAN UP
- POOLING FREE MOUNTING
- SEALED HOLES
- SEALED OIL PLUGS
- SIMPLE WASHING
- SMOOTH SURFACES
- NO PLASTIC PLUGS

# Tradition. Innovation. Dedication.

Cleangeartech eye catching gearboxes are what can be defined as “tradition in the service of innovation”.

A new born business unit, Cleangeartech, has its roots in a long story of two engineers, father and son, who managed to keep up with a continuous technological progress in the mechanical transmission industry.

It all began with a hydrodynamic speed variator invented by Giuseppe Speggorin in 1955.

In 1983 Giuseppe's son, Stefano Speggorin, founded his own company, Hydro-Mec Spa, now one important manufactures of high quality and modular gearboxes.

In 2006 Stefano decided to face another challenge, this time coming directly from the end users. He designed a range of stainless steel products initially for food industry; same year Hydro-Mec started manufacturing. As time passed, it became obvious that this project deserved its own story.

In 2016 Cleangeartech brand and business unit started.

Today it is division with a highly technological manufacturing, evolving worldwide sales network and a strong focus on R&D activities. Cleangeartech is deeply committed to providing a high level of service supplying an exceptional product to such demanding industries like Food & Beverage, Meat & Poultry, Marine, Chemical and Pharmaceutical.

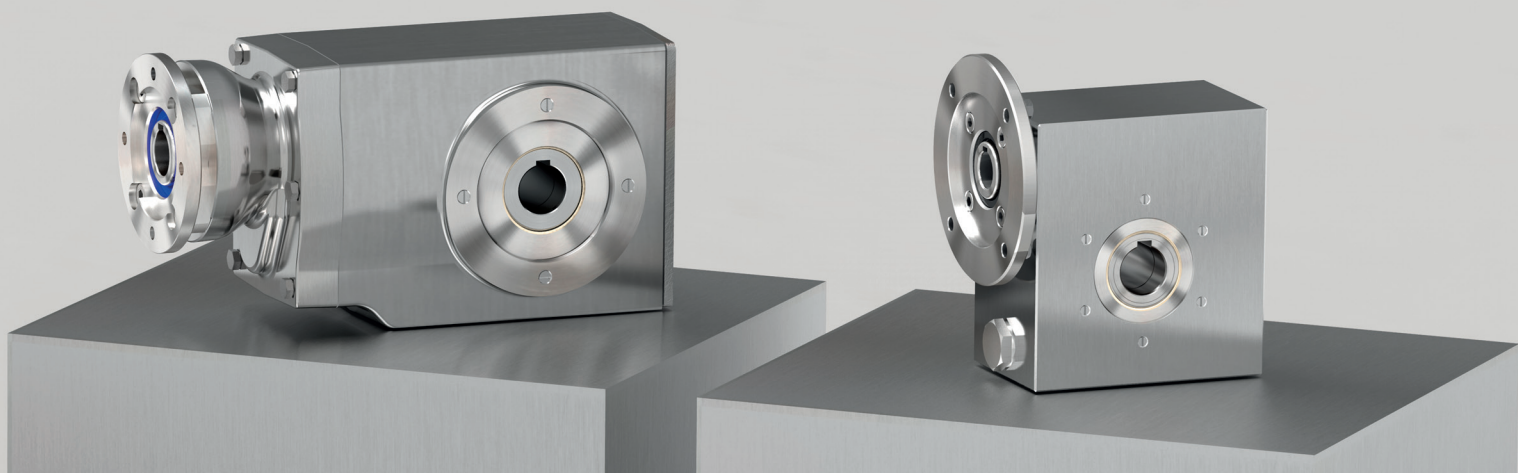

## *Tradizione. Innovazione. Dedizione.*

*I riduttori della Cleangeartech possono essere definiti come simbolo della “tradizione al servizio dell’innovazione”.*

*Oggi Cleangeartech sviluppa le sue radici nella lunga storia di successo di due ingegneri, padre e figlio, i quali hanno saputo tenere il passo del continuo progresso tecnologico nel settore della trasmissione meccanica.*

*Tutto ebbe inizio nel 1955 quando Giuseppe Speggorin inventò il variatore idraulico.*







*Nel 1983 il figlio di Giuseppe, Stefano Speggorin, in seguito a molti anni di affiancamento al padre, fondò la sua azienda, Hydro-Mec Spa, oggi un importante produttore Italiano di riduttori modulari.*



*Successivamente, nel 2006, si decise di affrontare un'altra sfida, ma questa volta proveniente dagli utilizzatori finali, e questo diede origine ad una gamma di prodotti in acciaio inossidabile, inizialmente dedicata all'industria alimentare, messa poi in produzione nel corso dello stesso anno. Con il passare del tempo divenne sempre più evidente che questo progetto meritava di avere una storia tutta sua. A questo proposito, nel 2016, nacque la divisione Cleangeartech.*

*Oggi è una azienda con una produzione ad alto livello tecnologico, una rete distributiva globale in costante evoluzione e una particolare dedizione alla ricerca e allo sviluppo. Cleangeartech è profondamente impegnata ad offrire un elevato livello di servizio, fornendo prodotti di eccellenza per settori molto esigenti, quali Alimentare e Bevande, Carne e Pollame, Navale, Chimica e Farmaceutica.*

# OEM Applications guide

Guida alle applicazioni per gli OEM

<div style="background-color: #808080; color: white; padding: 2px; display: inline-block; font-weight: bold;">Z</div> <b>Z Series</b> <i>Serie Z</i> <div style="background-color: #008080; color: white; padding: 2px; display: inline-block; font-weight: bold;">L</div> <b>L Series</b> <i>Serie L</i> <div style="background-color: #000080; color: white; padding: 2px; display: inline-block; font-weight: bold;">I</div> <b>I Series</b> <i>Serie I</i>	<b>Conditions of use</b> <i>Condizioni di utilizzo</i>	<b>Suggested range</b> <i>Gamma suggerita</i>					
		<b>Possible contact with processing product</b> <i>Possibile contatto con il prodotto</i>		<b>Only in proximity to the processing product</b> <i>In prossimità del prodotto</i>			
		Best	Medium	Best	Medium		
<b>Meat &amp; Poultry</b> <i>Industria della carne</i> 	<b>Salt</b> <i>Salato</i>	<div style="background-color: #000080; color: white; padding: 2px; display: inline-block; font-weight: bold;">I</div>	<div style="background-color: #008080; color: white; padding: 2px; display: inline-block; font-weight: bold;">L</div>		<div style="background-color: #008080; color: white; padding: 2px; display: inline-block; font-weight: bold;">L</div>		
	<b>Acid sanitization</b> <i>Lavaggio acido</i>	<div style="background-color: #000080; color: white; padding: 2px; display: inline-block; font-weight: bold;">I</div>	<div style="background-color: #008080; color: white; padding: 2px; display: inline-block; font-weight: bold;">L</div>		<div style="background-color: #008080; color: white; padding: 2px; display: inline-block; font-weight: bold;">L</div>		
	<b>Alkaline sanitization</b> <i>Lavaggio alcalino</i>	<div style="background-color: #000080; color: white; padding: 2px; display: inline-block; font-weight: bold;">I</div>		<div style="background-color: #008080; color: white; padding: 2px; display: inline-block; font-weight: bold;">L</div>	<div style="background-color: #008080; color: white; padding: 2px; display: inline-block; font-weight: bold;">L</div>		<div style="background-color: #808080; color: white; padding: 2px; display: inline-block; font-weight: bold;">Z</div>
	<b>Normal cleaning - Moist</b> <i>Lavaggio normale - umidità</i>	<div style="background-color: #000080; color: white; padding: 2px; display: inline-block; font-weight: bold;">I</div>		<div style="background-color: #008080; color: white; padding: 2px; display: inline-block; font-weight: bold;">L</div>	<div style="background-color: #808080; color: white; padding: 2px; display: inline-block; font-weight: bold;">Z</div>		<div style="background-color: #808080; color: white; padding: 2px; display: inline-block; font-weight: bold;">Z</div>
<b>Seafood Processing</b> <i>Industria della lavorazione del pesce</i> 	<b>Salt</b> <i>Salato</i>	<div style="background-color: #000080; color: white; padding: 2px; display: inline-block; font-weight: bold;">I</div>	<div style="background-color: #008080; color: white; padding: 2px; display: inline-block; font-weight: bold;">L</div>		<div style="background-color: #008080; color: white; padding: 2px; display: inline-block; font-weight: bold;">L</div>		
	<b>Acid sanitization</b> <i>Lavaggio acido</i>	<div style="background-color: #000080; color: white; padding: 2px; display: inline-block; font-weight: bold;">I</div>	<div style="background-color: #008080; color: white; padding: 2px; display: inline-block; font-weight: bold;">L</div>		<div style="background-color: #008080; color: white; padding: 2px; display: inline-block; font-weight: bold;">L</div>		
	<b>Alkaline sanitization</b> <i>Lavaggio alcalino</i>	<div style="background-color: #000080; color: white; padding: 2px; display: inline-block; font-weight: bold;">I</div>		<div style="background-color: #008080; color: white; padding: 2px; display: inline-block; font-weight: bold;">L</div>	<div style="background-color: #008080; color: white; padding: 2px; display: inline-block; font-weight: bold;">L</div>		<div style="background-color: #808080; color: white; padding: 2px; display: inline-block; font-weight: bold;">Z</div>
	<b>Normal cleaning - Moist</b> <i>Lavaggio normale - umidità</i>	<div style="background-color: #000080; color: white; padding: 2px; display: inline-block; font-weight: bold;">I</div>		<div style="background-color: #008080; color: white; padding: 2px; display: inline-block; font-weight: bold;">L</div>		<div style="background-color: #808080; color: white; padding: 2px; display: inline-block; font-weight: bold;">Z</div>	
<b>Fruit &amp; Vegetables</b> <i>Frutta e verdura</i> 	<b>Salt</b> <i>Salato</i>				<div style="background-color: #008080; color: white; padding: 2px; display: inline-block; font-weight: bold;">L</div>		
	<b>Acid sanitization</b> <i>Lavaggio acido</i>				<div style="background-color: #008080; color: white; padding: 2px; display: inline-block; font-weight: bold;">L</div>		
	<b>Alkaline sanitization</b> <i>Lavaggio alcalino</i>	<div style="background-color: #000080; color: white; padding: 2px; display: inline-block; font-weight: bold;">I</div>		<div style="background-color: #008080; color: white; padding: 2px; display: inline-block; font-weight: bold;">L</div>	<div style="background-color: #008080; color: white; padding: 2px; display: inline-block; font-weight: bold;">L</div>		<div style="background-color: #808080; color: white; padding: 2px; display: inline-block; font-weight: bold;">Z</div>
	<b>Normal cleaning - Moist</b> <i>Lavaggio normale - umidità</i>	<div style="background-color: #000080; color: white; padding: 2px; display: inline-block; font-weight: bold;">I</div>		<div style="background-color: #008080; color: white; padding: 2px; display: inline-block; font-weight: bold;">L</div>	<div style="background-color: #808080; color: white; padding: 2px; display: inline-block; font-weight: bold;">Z</div>		<div style="background-color: #808080; color: white; padding: 2px; display: inline-block; font-weight: bold;">Z</div>
<b>Dairy</b> <i>Latte e derivati</i> 	<b>Salt</b> <i>Salato</i>	<div style="background-color: #000080; color: white; padding: 2px; display: inline-block; font-weight: bold;">I</div>	<div style="background-color: #008080; color: white; padding: 2px; display: inline-block; font-weight: bold;">L</div>		<div style="background-color: #008080; color: white; padding: 2px; display: inline-block; font-weight: bold;">L</div>		
	<b>Acid sanitization</b> <i>Lavaggio acido</i>	<div style="background-color: #000080; color: white; padding: 2px; display: inline-block; font-weight: bold;">I</div>	<div style="background-color: #008080; color: white; padding: 2px; display: inline-block; font-weight: bold;">L</div>		<div style="background-color: #008080; color: white; padding: 2px; display: inline-block; font-weight: bold;">L</div>		
	<b>Alkaline sanitization</b> <i>Lavaggio alcalino</i>	<div style="background-color: #000080; color: white; padding: 2px; display: inline-block; font-weight: bold;">I</div>		<div style="background-color: #008080; color: white; padding: 2px; display: inline-block; font-weight: bold;">L</div>		<div style="background-color: #808080; color: white; padding: 2px; display: inline-block; font-weight: bold;">Z</div>	
	<b>Normal cleaning - Moist</b> <i>Lavaggio normale - umidità</i>	<div style="background-color: #000080; color: white; padding: 2px; display: inline-block; font-weight: bold;">I</div>		<div style="background-color: #008080; color: white; padding: 2px; display: inline-block; font-weight: bold;">L</div>		<div style="background-color: #808080; color: white; padding: 2px; display: inline-block; font-weight: bold;">Z</div>	
<b>Flours and derivatives</b> <i>Farine e derivati</i> 	<b>Salt</b> <i>Salato</i>	<div style="background-color: #000080; color: white; padding: 2px; display: inline-block; font-weight: bold;">I</div>	<div style="background-color: #008080; color: white; padding: 2px; display: inline-block; font-weight: bold;">L</div>				
	<b>Acid sanitization</b> <i>Lavaggio acido</i>	<div style="background-color: #000080; color: white; padding: 2px; display: inline-block; font-weight: bold;">I</div>	<div style="background-color: #008080; color: white; padding: 2px; display: inline-block; font-weight: bold;">L</div>				
	<b>Alkaline sanitization</b> <i>Lavaggio alcalino</i>	<div style="background-color: #000080; color: white; padding: 2px; display: inline-block; font-weight: bold;">I</div>		<div style="background-color: #008080; color: white; padding: 2px; display: inline-block; font-weight: bold;">L</div>		<div style="background-color: #808080; color: white; padding: 2px; display: inline-block; font-weight: bold;">Z</div>	
	<b>Normal cleaning</b> <i>Lavaggio normale</i>	<div style="background-color: #000080; color: white; padding: 2px; display: inline-block; font-weight: bold;">I</div>		<div style="background-color: #008080; color: white; padding: 2px; display: inline-block; font-weight: bold;">L</div>	<div style="background-color: #808080; color: white; padding: 2px; display: inline-block; font-weight: bold;">Z</div>		<div style="background-color: #808080; color: white; padding: 2px; display: inline-block; font-weight: bold;">Z</div>
<b>Beverage</b> <i>Bevande</i> 	<b>Salt</b> <i>Salato</i>	<div style="background-color: #000080; color: white; padding: 2px; display: inline-block; font-weight: bold;">I</div>	<div style="background-color: #008080; color: white; padding: 2px; display: inline-block; font-weight: bold;">L</div>		<div style="background-color: #008080; color: white; padding: 2px; display: inline-block; font-weight: bold;">L</div>		
	<b>Acid sanitization</b> <i>Lavaggio acido</i>	<div style="background-color: #000080; color: white; padding: 2px; display: inline-block; font-weight: bold;">I</div>	<div style="background-color: #008080; color: white; padding: 2px; display: inline-block; font-weight: bold;">L</div>		<div style="background-color: #008080; color: white; padding: 2px; display: inline-block; font-weight: bold;">L</div>		
	<b>Alkaline sanitization</b> <i>Lavaggio alcalino</i>	<div style="background-color: #000080; color: white; padding: 2px; display: inline-block; font-weight: bold;">I</div>		<div style="background-color: #008080; color: white; padding: 2px; display: inline-block; font-weight: bold;">L</div>		<div style="background-color: #808080; color: white; padding: 2px; display: inline-block; font-weight: bold;">Z</div>	
	<b>Normal cleaning - Moist</b> <i>Lavaggio normale - umidità</i>	<div style="background-color: #000080; color: white; padding: 2px; display: inline-block; font-weight: bold;">I</div>		<div style="background-color: #008080; color: white; padding: 2px; display: inline-block; font-weight: bold;">L</div>	<div style="background-color: #808080; color: white; padding: 2px; display: inline-block; font-weight: bold;">Z</div>		<div style="background-color: #808080; color: white; padding: 2px; display: inline-block; font-weight: bold;">Z</div>

		Conditions of use <i>Condizioni di utilizzo</i>	Suggested range <i>Gamma suggerita</i>				
			Possible contact with processing product <i>Possibile contatto con il prodotto</i>		Only in proximity to the processing product <i>In prossimità del prodotto</i>		
			Best	Medium	Best	Medium	
<b>Z Series</b> <i>Serie Z</i> <b>L Series</b> <i>Serie L</i> <b>I Series</b> <i>Serie I</i>	<b>Food packaging processing</b> <i>Imballaggio alimentare</i>	Salt <i>Salato</i>	I	L		L	
		Acid sanitization <i>Lavaggio acido</i>	I	L		L	
		Alkaline sanitization <i>Lavaggio alcalino</i>	I		L		Z
		Normal cleaning - Moist <i>Lavaggio normale - umidità</i>	I		L	Z	Z
<b>Bakery applications</b> <i>Prodotti da forno</i>		Salt <i>Salato</i>					
		Acid sanitization <i>Lavaggio acido</i>					
		Alkaline sanitization <i>Lavaggio alcalino</i>	I				Z
		Normal cleaning <i>Lavaggio normale</i>	I			Z	Z
<b>Animal food applications</b> <i>Mangimi</i>		Salt <i>Salato</i>	I	L		L	
		Acid sanitization <i>Lavaggio acido</i>	I	L		L	
		Alkaline sanitization <i>Lavaggio alcalino</i>	I				Z
		Normal cleaning - Moist <i>Lavaggio normale - umidità</i>	I			Z	Z
<b>Marine</b> <i>Settore marino e navale</i>		On deck <i>Esterno</i>				L	
		Indoor <i>Sotto coperta</i>				I	

**For the Z series due to the infinite variety of chemical mixtures please use our test plate to test the following fields**  
*Data l'infinita varietà di misture chimiche, per la serie Z è consigliato usare la nostra targhetta per effettuare eventuali test*

**Pharmaceutical & Chemical**  
*Chimica & Farmaceutica*

**Highly corrosive and harsh environment**  
*Ambiente altamente corrosivo*

**Outdoor application**  
*Applicazioni in ambiente esterno*

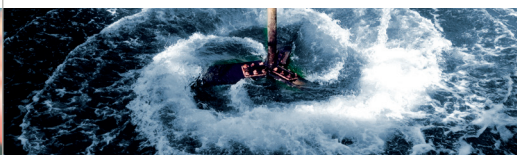
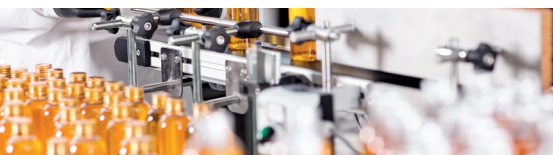

# 3 Lines of specific products

Gamme di prodotto

## Z NTT series

Aluminum worm gearboxes  
with NTT treatment

*Riduttori a vite senza fine in alluminio  
con trattamento NTT*

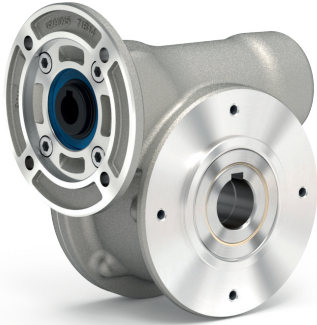

Aluminum ratio multipliers  
with NTT treatment

*Riduttori coassiali ad uno stadio  
in alluminio con trattamento NTT*



## L SHIELD series

PATENTED

Worm gearboxes

*Riduttori a vite senza fine*

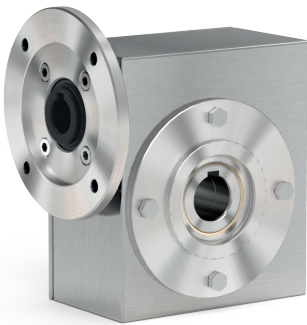

Coaxial gearboxes

*Riduttori coassiali*

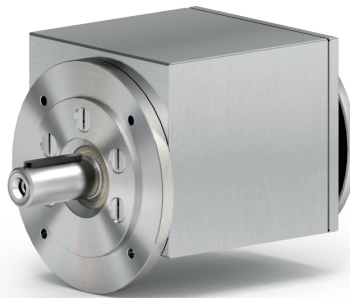

Helical bevel gearboxes

*Riduttori a coppia conica*



## I FULL STAINLESS STEEL series

Worm gearboxes

*Riduttori a vite senza fine*

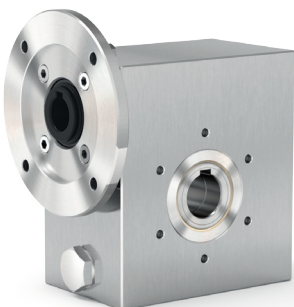

Ratio multipliers

*Riduttori coassiali ad uno stadio*

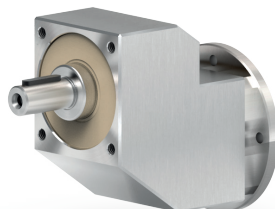

Helical bevel gearboxes

*Riduttori a coppia conica*

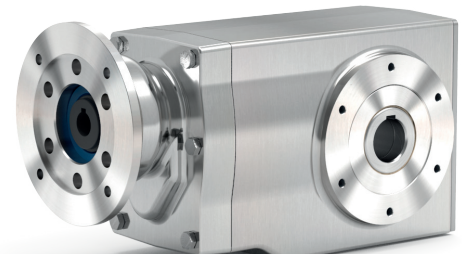

## APM series

Aluminum electric motors  
*Motori elettrici in alluminio*



A range suitable for applications where no ribs are required to hold dust, in close position to the products processed, usable in applications with light sanitization processes.

*Una gamma adatta per applicazioni in cui è richiesto un design igienico posizionabile in vicinanza dei prodotti trattati, con processi di lavaggio e sanificazione leggera.*

The "L" series is an aluminum gearbox completely shielded and sealed with stainless steel 316L case, an alternative to the full stainless steel products, suitable for many applications in contact with detergents, chemicals, wash down and salty environment.

*Una gamma di riduttori in alluminio completamente sigillati e schermati all'interno di un carter sigillato in acciaio inox 316L, un'alternativa ai prodotti interamente in acciaio inossidabile, adatta per molte applicazioni a contatto con detersivi, prodotti chimici, lavaggi e ambienti salati.*

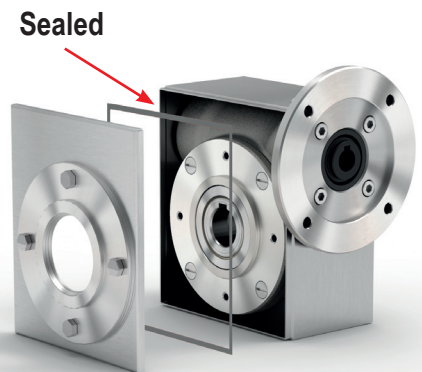

## SPM series

Stainless steel  
premium electric motors  
*Motori elettrici in acciaio inox*



Strong full stainless steel products, suitable for most applications requiring a very high degree of protection against long term maintenance is possible.

*Una gamma completamente in acciaio inossidabile, adatta alla maggior parte delle applicazioni che richiedono un grado molto alto di protezione.*

# Premium input coupling

Giunto in entrata

PATENTED

Direct mounting - No settings - No screw

Montaggio diretto - No settaggi - No viti

1

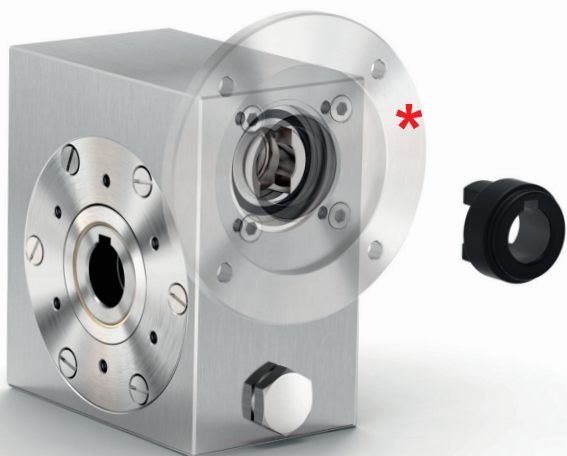

\* Do not mount oil seals on motor flange

Non montare anelli di tenuta nella flangia motore

2

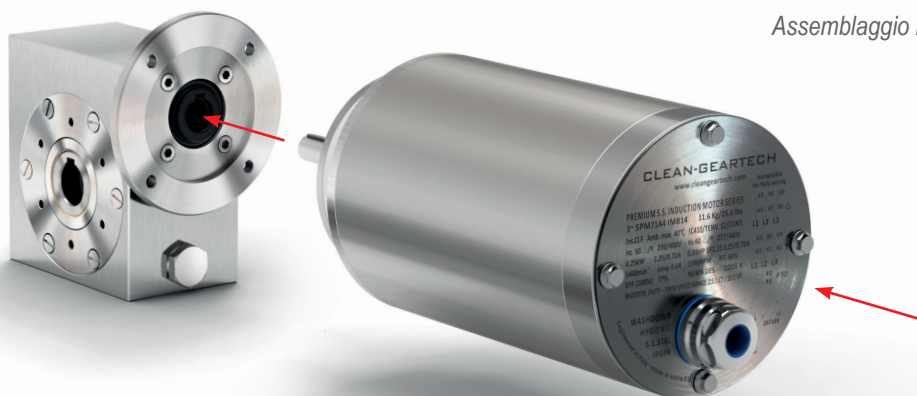

Motor assembly

Assemblaggio motore

3













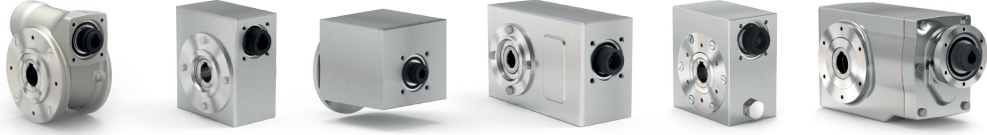







Available as an option for the motor range from IEC 56 to IEC 112

Disponibile come opzione per motori da IEC 56 a IEC 112



# Coupling chart

Tabella combinazione giunti

						GROUP	INPUT DIAMETER Ø	MATERIAL P = Polymer Z = Zamak	
Z30	-	-	-	I30	-	KA	09	P	
							11	P	
Z45	LD45	-	-	I45	-	KB	09	P	
							11	P	
							14	P	
Z50	LD50	-	X22L	I50	-	KC	09	P	
							11	P	
							14	P	
							19	Z	
Z63	LD63	402L	X32L X42L	I63	X42I	KD	11	P	
							14	P	
			19				P		
			24				Z		
Z85	LD85	602L	X52L X62L	I85	X62I	KE	14	P	
							19	P	
			24				Z		
			28				Z		

\* While using these couplings, replace the motor shaft key with the shorter one supplied with the kit.  
 Per l'utilizzo di questi giunti usare la chiavetta ridotta fornita nei kit.

### Aluminum worm gearboxes

*Riduttori a vite senza fine in alluminio*



#### Section 1

Features - Caratteristiche	1-3
How to order - Codifica	1-5
Useful formulas - Formule utili	1-7
How to select a gearbox - Come selezionare un riduttore	1-8
Z30	1-9
Z45	1-11
Z50	1-13
Z63	1-15
Z85	1-17

### Aluminum ratio multipliers

*Riduttori ad uno stadio in alluminio*

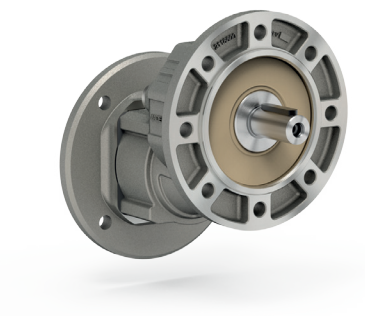

#### Section 2

Features - Caratteristiche	2-3
How to order - Codifica	2-5
Useful formulas - Formule utili	2-7
How to select a gearbox - Come selezionare un riduttore	2-8
211Z	2-9

**Stainless steel shielded worm gearboxes**

*Riduttori a vite senza fine schermati in acciaio inox*

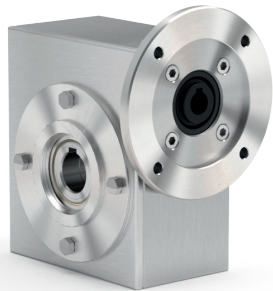

**Section 3**

Features - Caratteristiche	3-3
How to order - Codifica	3-5
Useful formulas - Formule utili	3-7
How to select a gearbox - Come selezionare un riduttore	3-8
LD45	3-9
LD50	3-11
LD63	3-13
LD85	3-15

**Stainless steel shielded ratio multipliers**

*Riduttori ad uno stadio schermati in acciaio inox*

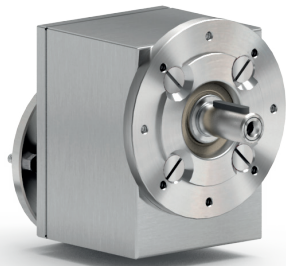

**Section 4**

Features - Caratteristiche	4-3
How to order - Codifica	4-5
Useful formulas - Formule utili	4-7
How to select a gearbox - Come selezionare un riduttore	4-8
411L	4-9
511L	4-11

**Stainless steel shielded coaxial gearboxes**

*Riduttori coassiali schermati in acciaio inox*

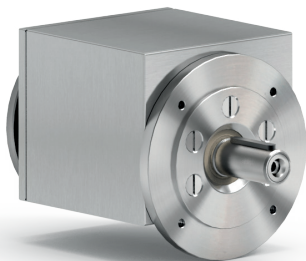

**Section 5**

Features - Caratteristiche	5-3
How to order - Codifica	5-5
Useful formulas - Formule utili	5-7
How to select a gearbox - Come selezionare un riduttore	5-8
402L	5-9
602L	5-11

**Stainless steel shielded helical bevel gearboxes**

*Riduttori a coppia conica schermati in acciaio inox*

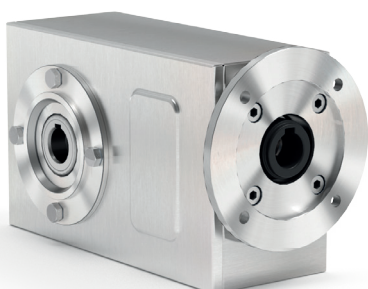

**Section 6**

Features - Caratteristiche	6-3
How to order - Codifica	6-5
Useful formulas - Formule utili	6-7
How to select a gearbox - Come selezionare un riduttore	6-8
X22L	6-9
X32L	6-11
X42L	6-13
X52L	6-15
X62L	6-17

### Full stainless steel worm gearboxes

*Riduttori a vite senza fine completamente in acciaio inox*

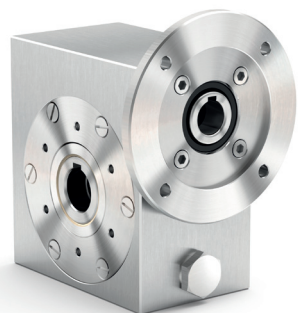

## Section 7

Features - Caratteristiche	7-3
How to order - Codifica	7-5
Useful formulas - Formule utili	7-7
How to select a gearbox - Come selezionare un riduttore	7-8
I30	7-9
I45	7-11
I50	7-13
I63	7-15
I85	7-17
I11	7-19

### Full stainless steel ratio multipliers

*Riduttori ad uno stadio completamente in acciaio inox*

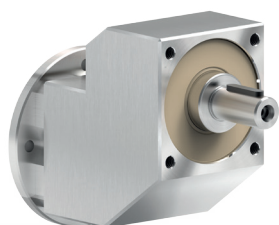

## Section 8

Features - Caratteristiche	8-3
How to order - Codifica	8-5
Useful formulas - Formule utili	8-7
How to select a gearbox - Come selezionare un riduttore	8-8
4111	8-9

### Full stainless steel helical bevel gearboxes

*Riduttori a coppia conica completamente in acciaio inox*

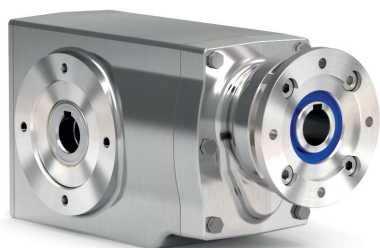

## Section 9

Features - Caratteristiche	9-3
How to order - Codifica	9-5
Useful formulas - Formule utili	9-7
How to select a gearbox - Come selezionare un riduttore	9-8
X42I	9-9
X62I	9-11

## Aluminum premium electric motors

*Motori elettrici in alluminio*



### Section **AM**

Features - Caratteristiche  
Dimensions - Dimensioni

am-3  
am-5

## Stainless steel premium electric motors

*Motori elettrici in acciaio inox*



### Section **SM**

Features - Caratteristiche  
Dimensions - Dimensioni

sm-2  
sm-4

## Certifications

*Certificazioni*

### Section **C**

Certifications - Certificazioni

C-1

## Information

*Informazioni*

### Section **I**

Important information - Informazioni importanti

I-1

## General sales and warranty conditions

*Condizioni generali di vendita*

### Section **G**

International  
Condizioni generali di vendita in Italia

G-1  
G-2



**z** VFZ series  
Aluminum worm gearboxes

*Riduttori a vite senza fine in alluminio*

Section **1**  
Sezione 1

This range is  IP69K  **ATEX**  
(on request)  **CE**  **NTT**  
NANOTECHNOLOGY  
TREATMENT  **NSF**  
COMPONENT certified

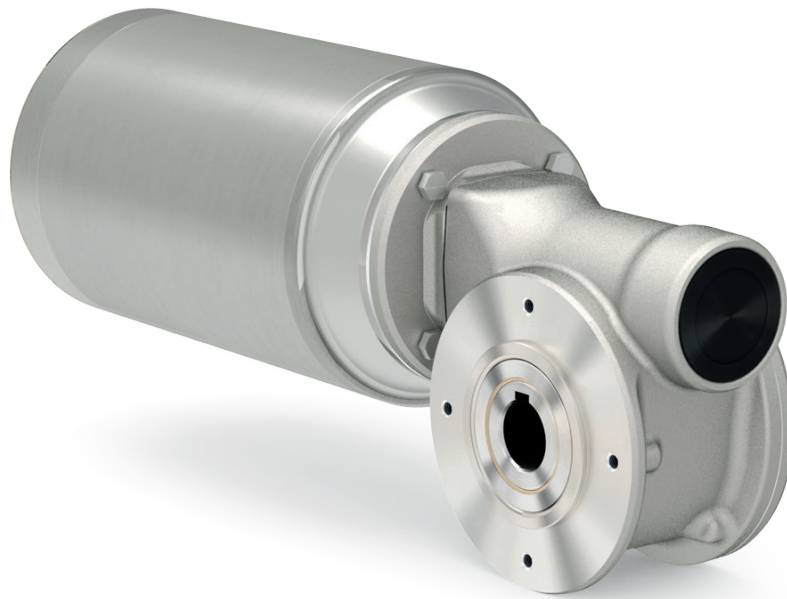

# FEATURES

Caratteristiche

## VFZ series Aluminum worm gearboxes

Riduttori a vite senza fine in alluminio

Type Tipo	Torque Coppia	Center distance Interasse	Input power Potenza in entrata	Hollow output shaft Albero cavo in uscita
Z30	21 Nm	30 mm	0.06 ÷ 0.18 kW	ø14 mm
Z45	41 Nm	45 mm	0.09 ÷ 0.37 kW	ø18 mm
Z50	72 Nm	50 mm	0.12 ÷ 0.75 kW	ø25 mm
Z63	147 Nm	63 mm	0.37 ÷ 1.8 kW	ø25 mm
Z85	347 Nm	85 mm	0.55 ÷ 4.0 kW	ø35 mm



This product is:

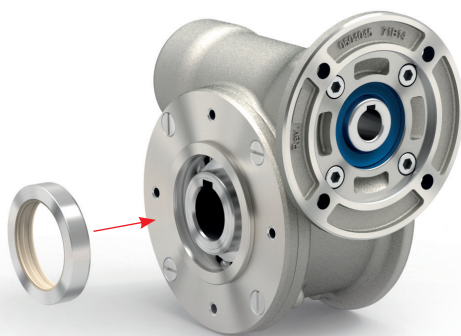
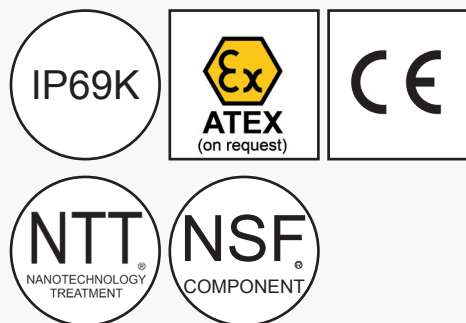

Twin viton seals with stainless steel 316L shield.



Doppio anello di tenuta in viton con schermo protettivo in acciaio inox AISI 316L.



**NTT™** stands for a special surface treatment which results in modified external properties of the complete unit in order to get a smooth surface and an higher corrosion resistance.

NTT™ è uno speciale trattamento che come risultato ha la modifica delle proprietà superficiali del riduttore allo scopo di ottenere una superficie liscia e con maggiore resistenza alla corrosione.





**Output shaft and hollow shaft in AISI 316L.**

*Mozzo e albero in uscita in AISI 316L.*

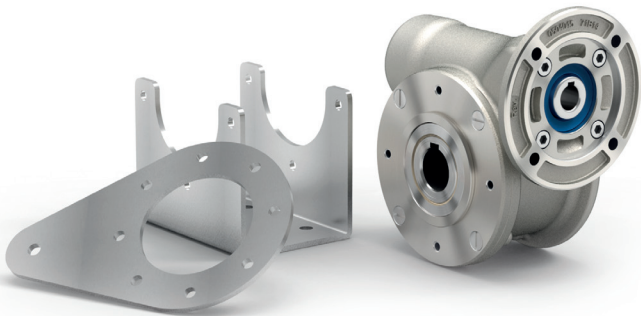

**All stainless steel 316L hardware.**

*Viteria e kit in acciaio inox AISI 316L.*



**CuSn12Ni (C91700) Nickel bronze worm gears are centrifugally cast onto an iron hub for maximum strength and superior life. Removable hollow shaft with key for safe torque transmissions.**

*Corona in bronzo al Nickel CuSn12Ni (C91700) centrifugato e mozzo in acciaio inox per massima resistenza e durata superiore. Albero cavo removibile con chiavetta mozzo/corona.*

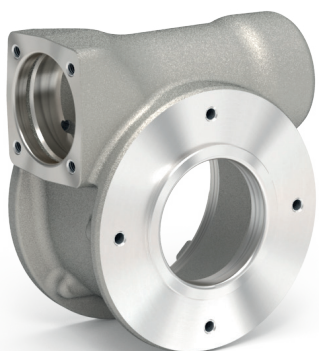

















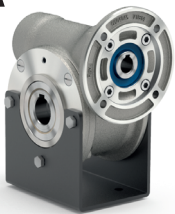



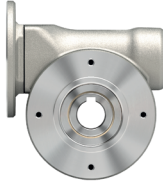

**Housing with special smooth surfaces.**

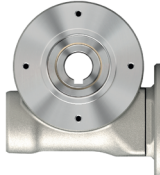
*Cassa con finitura speciale liscia.*

# How to order

Codifica

P	Z50	UN	10	I
Type <i>Tipo</i>	Size <i>Grandezza</i>	Mounting <i>Montaggio</i>	Ratio <i>Rapporto</i>	Hub <i>Mozzo corona</i>
<b>P</b> 	<b>Z30</b> <b>Z45</b> <b>Z50</b> <b>Z63</b> <b>Z85</b>	<b>UN</b> 	See technical data table <i>Vedi tabelle dati tecnici</i>	<b>I</b> 
<b>M</b> 		<b>FC</b> 		Z30 -> $\varnothing 14$ Z45 -> $\varnothing 18$ Z50 -> $\varnothing 25$ Z63 -> $\varnothing 25$ Z85 -> $\varnothing 35$
<b>B</b> 		<b>FL</b> 		<b>Z</b> <b>Inch</b> Z45 -> $\varnothing 0.750''$ Z50 -> $\varnothing 1.000''$ Z63 -> $\varnothing 1.125''$ Z85 -> $\varnothing 1.500''$
<b>R</b> 		<b>BR</b> 		<b>PA</b> 

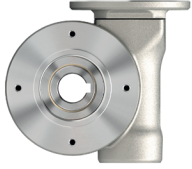
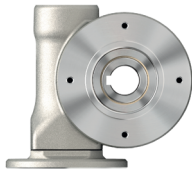
<b>S</b>	<b>-R</b>	<b>B3</b>	<b>D</b>	With Type M specify terminal box position <i>Con tipo M specificare posizione morsettiera</i>
Output shaft <i>Albero lento</i>	Motor size <i>Grandezza motore</i>	Mounting position <i>Posizione di montaggio</i>	Input bore <i>Foro entrata</i>	Terminal box position <i>Posizione morsettiera</i>
<p><b>Ø</b></p> 	<p><b>Flange</b> <i>Flange</i></p> 	<p><b>B3</b></p> 	<p><b>With coupling</b> <i>Con giunto</i></p> 	<p><b>A</b></p> 
<p><b>S</b></p> 	<p><b>IEC B14</b></p> <ul style="list-style-type: none"> <li><b>-O</b> -&gt; 56 B14 (ø80)</li> <li><b>-P</b> -&gt; 63 B14 (ø90)</li> <li><b>-Q</b> -&gt; 71 B14 (ø105)</li> <li><b>-R</b> -&gt; 80 B14 (ø120)</li> <li><b>-T</b> -&gt; 90 B14 (ø140)</li> <li><b>-U</b> -&gt; 100-112B14 (ø160)</li> </ul>	<p><b>B8</b></p> 	<p><b>A</b> -&gt; 9mm <b>B</b> -&gt; 11mm <b>C</b> -&gt; 14mm <b>D</b> -&gt; 19mm <b>E</b> -&gt; 24mm <b>F</b> -&gt; 28mm <b>W</b> -&gt; ø0.625" <b>X</b> -&gt; ø0.875" <b>Y</b> -&gt; ø1.125"</p>	<p><b>B</b></p> 
	<p><b>NEMA</b></p> <ul style="list-style-type: none"> <li><b>-W</b> -&gt; 56C (ø6.5")</li> <li><b>-X</b> -&gt; 143/5TC (ø6.5")</li> <li><b>-Y</b> -&gt; 182/4TC (ø8.88")</li> </ul>	<p><b>B6</b></p> 		<p><b>C</b></p> 
	<p><b>Without flange</b> <i>Senza flangia</i></p>  <ul style="list-style-type: none"> <li><b>-M</b> -&gt; Metric</li> <li><b>-N</b> -&gt; Nema</li> </ul>	<p><b>B7</b></p> 	<p><b>0</b> <b>Ready for input coupling</b> <i>Predisposto per giunto</i></p> 	<p><b>D</b></p> 
	<p><b>Type R</b> <i>Tipo R</i></p>  <ul style="list-style-type: none"> <li><b>-O</b> -&gt; Metric</li> </ul>	<p><b>V5</b></p> 	<p><b>Type R</b> <i>Tipo R</i></p> <ul style="list-style-type: none"> <li><b>-</b> <b>Standard bore</b> <i>Foro standard</i></li> </ul>	
		<p><b>V6</b></p> 		

# Useful formulas

Formule utili

## Required power - Potenza richiesta

Lifting - Sollevamento

Rotation - Rotazione

Linear movement - Traslazione

$$P_{[kW]} = \frac{M_{[Kg]} \cdot g_{[9.81]} \cdot v_{[m/s]}}{1000}$$

$$P_{[kW]} = \frac{M_{[Nm]} \cdot n_{[rpm]}}{9550}$$

$$P_{[kW]} = \frac{F_{[N]} \cdot v_{[m/s]}}{1000}$$

## Torque - Coppia

$$M_{[Nm]} = \frac{9550 \cdot P_{[kW]}}{n_{[rpm]}}$$

$$M_{[lb\ in]} = \frac{63030 \cdot P_{[HP]}}{n_{[rpm]}}$$

## Radial loads - Carichi radiali

Radial load generated by external transmissions keyed onto input and/or output shafts.

Forza radiale generata da organi di trasmissione calettati sugli alberi di ingresso e/o uscita.

$$F_{R[N]} = \frac{M_{[Nm]} \cdot 2000}{d_{[mm]}} \cdot f_k$$

$$F_{R[N]} = \frac{M_{[lb\ in]} \cdot 8.9}{d_{[in]}} \cdot f_k$$

**M:** Output torque - *Momento torcente*

**d:** Diam. of driving element - *Diametro primitivo*

**f<sub>k</sub>:** Factor - *Coefficiente di trasformazione*

1.15: Gearwheels - *Ingranaggi*

1.25: Chain sprochets - *Catena*

1.75: Narrow v-belt pulley - *Cinghia Trapezoidale*

2.50: Flat-belt pulley - *Cinghia piatta*

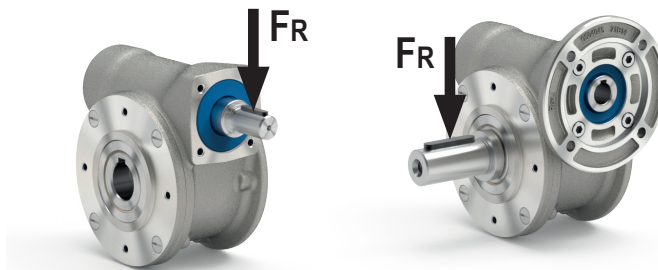

If your application requires higher radial loads, contact our technical office. Higher loads may be possible.

Nel caso la vostra applicazione richieda carichi radiali superiori consultare il nostro ufficio tecnico, valori maggiori possono essere accettati.

# How to select a gearbox

Come selezionare un riduttore

## A Select required torque (according to service factor)

Seleziona la coppia desiderata (comprensiva del fattore di servizio)

## B Select output speed

Seleziona la velocità in uscita

## C Select gear ratio in the line corresponding to the chosen motor power

Sulla riga corrispondente alla motorizzazione prescelta si può rilevare il rapporto di riduzione

## D Select motor flange available (if requested)

Scegli la flangia disponibile (se richiesta)

Gear size  
Grandezza  
riduttore

C

Ratio  
Rapporto

Transmitted torque  
Momento torcente  
trasmesso

Nominal power  
Potenza nominale

Flange code  
Codice flangia

Dynamic efficiency  
Rendimento dinamico

Input speed  
Velocità in entrata

Z30

21  
Nm

VFZ series

Aluminum worm gearboxes

Riduttori a vite senza fine in alluminio

Input speed ( $n_1$ ) = 1400 min<sup>-1</sup>

Output speed $n_2$ [min <sup>-1</sup> ]	Ratio i	Motor power $P_{1M}$ [kW]	Output torque $M_{2M}$ [Nm]	Service factor f.s	Nominal power $P_{1R}$ [kW]	Nominal torque $M_{2R}$ [Nm]	B5 motor flanges		B14 motor flanges		Dynamic efficiency RD	Tooth module [mm]	Ratio code
							-	-	-O 56	-P 63			
280	5	0.18	5	3.3	0.60	17			C		82	1.26	09
200	7	0.18	7	2.4	0.44	17			C		80	1.44	01
140	10	0.18	10	1.8	0.32	17			C		78	1.44	02
93	15	0.18	13	1.4	0.25	19			C		73	1.44	03
70	20	0.18	17	1.1	0.20	19			C		70	1.09	04
47	30	0.12	15	1.4	0.17	21			C		62	1.44	05
35	40	0.12	19	1.1	0.13	20			C		57	1.09	06
23	61	0.09	19	1.1	0.10	20			C		50	0.72	07
17.5	80	0.06	16	1.0	0.06	16			C		48	0.56	08
14	100	0.06*	16	0.5	0.03	8			C		40	0.45	10

B Output speed  
Velocità in uscita

Motor power  
Potenza motore

Service factor  
Fattore di servizio

A Nominal torque  
Momento torcente  
nominale

Nominal module  
Modulo nominale

Notes  
Note

### Type of load and starts per hour

Tipo di carico e avviamenti per ora

### Oper. hours per day

Ore di funz. giorn.

		Oper. hours per day			
		<2h	2÷8h	8÷16h	
Continuous or intermittent application with start / hour Applicazione continua o intermittente con numero operazioni/ora	≤ 10	Uniform - <i>Uniforme</i>	0.9	1	1.25
		Moderate - <i>Moderato</i>	1	1.25	1.5
		Heavy - <i>Forte</i>	1.25	1.5	1.75
Intermittent application with start / hour Applicazione intermittente con numero operazioni/ora	> 10	Uniform - <i>Uniforme</i>	1.25	1.5	1.75
		Moderate - <i>Moderato</i>	1.5	1.75	2
		Heavy - <i>Forte</i>	1.75	2	2.25

D Motor flange available  
Flange disponibili

B) Mounting with reduction bushing  
Montaggio con boccia di riduzione

C) Motor flange holes position/terminal box position  
Posizione fori flangia/basetta motore

B) Available without reduction bushing  
Disponibile anche senza boccia

# Z30

# 21 Nm

## VFZ series

## Aluminum worm gearboxes

Riduttori a vite senza fine in alluminio

Input speed ( $n_1$ ) = 1400 min<sup>-1</sup>

Output speed $n_2$ [min <sup>-1</sup> ]	Ratio $i$	Motor power $P_{1M}$ [kW]	Output torque $M_{2M}$ [Nm]	Service factor $f.s$	Nominal power $P_{1R}$ [kW]	Nominal torque $M_{2R}$ [Nm]	B5 motor flanges		B14 motor flanges		Dynamic efficiency RD	Tooth module [mm]	Ratio code
							-	-	-O 56	-P 63			
280	5	0.18	5	3.3	0.60	17			C		82	1.26	09
200	7	0.18	7	2.4	0.44	17			C		80	1.44	01
140	10	0.18	10	1.8	0.32	17			C		78	1.44	02
93	15	0.18	13	1.4	0.25	19			C		73	1.44	03
70	20	0.18	17	1.1	0.20	19			C		70	1.09	04
47	30	0.12	15	1.4	0.17	21			C		62	1.44	05
35	40	0.12	19	1.1	0.13	20			C		57	1.09	06
23	61	0.09	19	1.1	0.10	20			C		50	0.72	07
17.5	80	0.06	16	1.0	0.06	16			C		48	0.56	08
14	100	0.06*	16	0.5	0.03	8			C		40	0.45	10

\* Power higher than the maximum one which can be supported by the gearbox. Select according to the torque  $M_{2R}$

Potenza superiore a quella massima sopportabile dal riduttore. Selezionare in base al momento torcente  $M_{2R}$

Motor flanges available  
Flange motore disponibili



B) Supplied with reduction bushing  
Fornito con bussola di riduzione



B) Available on request without reduction bushing  
Disponibile a richiesta senza bussola di riduzione



C) Motor flange holes position  
Posizione fori flangia motore

### Lubrication

Lubrificazione

Unit Z30 is supplied with synthetic oil to assure long life lubrication.

Food grade oil is available on request.

See Table 1 for lubrication and recommended quantity.

See Table 2 for possible radial and axial loads on the gearbox.

Il riduttore tipo Z30 viene fornito con olio sintetico e lubrificazione tipo "long life".

Disponibile a richiesta olio alimentare.

Vedi Tabella 1 per oli e quantità consigliati.

Vedi Tabella 2 per i carichi radiali e assiali applicabili al riduttore.

Oil quantity for all positions:  
0.025Lt.

Quantità olio per tutte le posizioni: 0.025Lt.

Agip  
Telium VSF 320

Shell  
Omala S4 WE 320

### Radial and axial loads

Carichi radiali e assiali

#### Output shaft

Albero di uscita

$n_2$ [min <sup>-1</sup> ]	$F_A$ [N]	$F_R$ [N]
200	120	600
150	140	700
100	160	800
75	180	900
50	200	1000
25	250	1250
15	280	1400

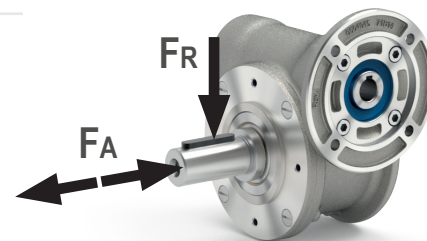

#### Input shaft

Albero in entrata

$n_1$ [min <sup>-1</sup> ]	$F_A$ [N]	$F_R$ [N]
1400	20	100

\* Strong axial loads in the DX direction are not allowed.

\* Non sono consentiti forti carichi assiali con direzione DX

**PZ30UN..** Basic gearbox  
*Riduttore base*

**Gearbox weight** 1.25 kg  
*Peso riduttore*

M. flanges	Kit code	øF	A
56B14	KZ304046	80	62
63B14	KZ304045	90	63

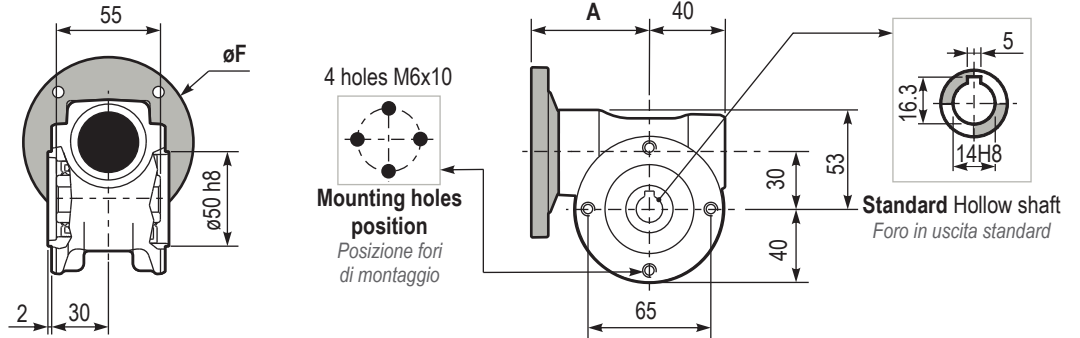

**PZ30PA..** Feet  
*Piedini*

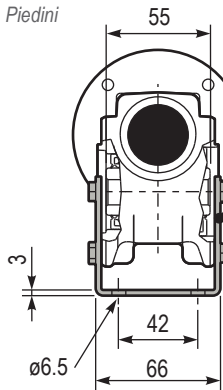

kit cod. KIZ309022

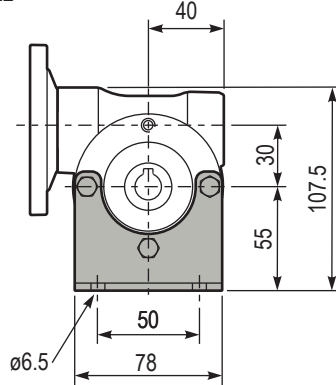

**PZ30PV..** Feet  
*Piedini*

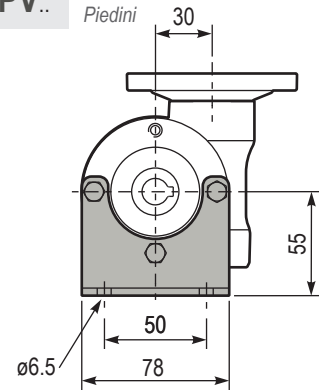

**PZ30FC..** Output flange  
*Flangia uscita*

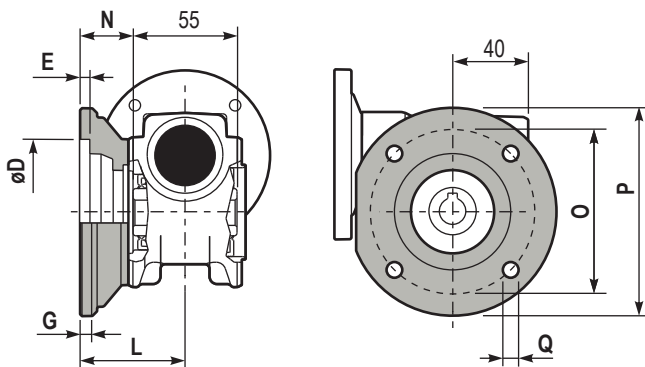

**PZ30BR..** Reaction arm  
*Braccio di reazione*

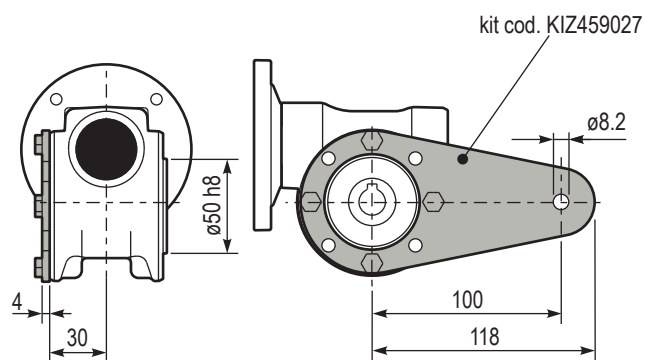

Type	øD	E	G	L	N	O	P	Q	Kit code
FC	50 <sup>+0.15</sup> / <sub>+0.05</sub>	6	6	50.5	23	68	80	7	KZ309010
FL	60 <sup>+0.15</sup> / <sub>+0.05</sub>	6	6	55.5	28	87	110	8.5	KZ459010

**RZ30UN..** Input shaft  
*Albero in entrata*

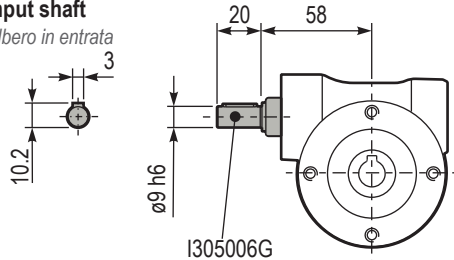

**PZ30..S..** Single output shaft  
*Albero semplice in uscita*

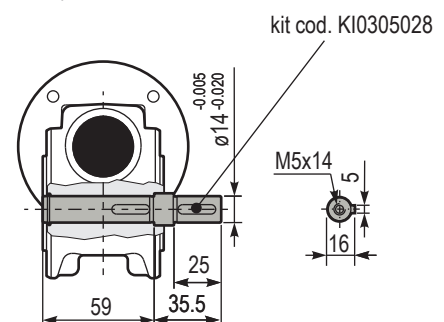

# Z45

# 41 Nm

## VFZ series Aluminum worm gearboxes

Riduttori a vite senza fine in alluminio

Input speed ( $n_1$ ) = 1400 min<sup>-1</sup>

Output speed $n_2$ [min <sup>-1</sup> ]	Ratio $i$	Motor power $P_{1M}$ [kW]	Output torque $M_{2M}$ [Nm]	Service factor $f.s$	Nominal power $P_{1R}$ [kW]	Nominal torque $M_{2R}$ [Nm]	B5 motor flanges		B14 motor flanges			Dynamic efficiency RD	Tooth module [mm]	Ratio code
							-	-	-O	-P	-Q			
200	7	0.37	14	2.2	0.80	30	-	-	56	63	71	80	2.2	01
140	10	0.37	20	1.5	0.57	30	-	-	C	C		79	2.2	02
100	14	0.37	27	1.1	0.41	30	-	-	C	C		77	2.4	03
67	21	0.37	36	1.2	0.43	41	-	-	C	C		67	1.6	04
50	28	0.25	31	1.3	0.33	41	-	-	C	C		65	2.5	05
38	37	0.25	40	1.0	0.26	41	-	-	C	C		63	1.8	06
30	46	0.25	46	0.9	0.22	41	-	-	C	C		59	1.5	07
23	60	0.18	41	1.0	0.18	41	-	-	C	C		56	1.2	08
20	70	0.12	31	1.0	0.12	30	-	-	C	C		54	1.0	09
13.7	102	0.09	31	1.0	0.09	29	-	-	C	C		49	0.72	10

Motor flanges available  
Flange motore disponibili



B) Supplied with reduction bushing  
Fornito con bussola di riduzione



B) Available on request without reduction bushing  
Disponibile a richiesta senza bussola di riduzione



C) Motor flange holes position  
Posizione fori flangia motore

### Lubrication

Lubrificazione

Unit Z45 is supplied with synthetic oil to assure long life lubrication.  
Food grade oil is available on request.

See Table 1 for lubrication and recommended quantity.

See Table 2 for possible radial and axial loads on the gearbox.

Il riduttore tipo Z45 viene fornito con olio sintetico e lubrificazione tipo "long life".

Disponibile a richiesta olio alimentare.

Vedi Tabella 1 per oli e quantità consigliati.

Vedi Tabella 2 per i carichi radiali e assiali applicabili al riduttore.

Oil quantity for  
all positions:  
0.08Lt.

Agip  
Telium VSF 320

Shell  
Omala S4 WE 320

Quantità olio per tutte  
le posizioni: 0.08Lt.

### Radial and axial loads

Carichi radiali e assiali

#### Output shaft

Albero di uscita

$n_2$ [min <sup>-1</sup> ]	$F_A$ [N]	$F_R$ [N]
200	180	900
150	200	1000
100	220	1100
75	240	1200
50	260	1400
25	300	1800
15	400	2000

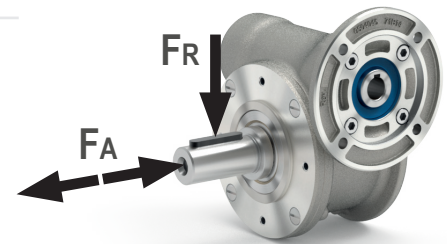

#### Input shaft

Albero in entrata

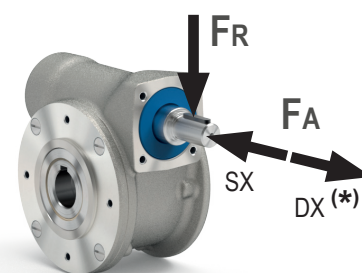

$n_1$ [min <sup>-1</sup> ]	$F_A$ [N]	$F_R$ [N]
1400	42	210

\* Strong axial loads in the DX direction are not allowed.

\* Non sono consentiti forti carichi assiali con direzione DX

Tab. 1

Tab. 2



41  
Nm

Z45

**PZ45UN..** Basic gearbox  
*Riduttore base*

**Gearbox weight** 2.50 kg  
*Peso riduttore*

M. flanges	Kit code	øF	A
56B14	KZ454049	80	71.5
63B14	KZ454047	90	74
71B14	KZ454045	105	71.5

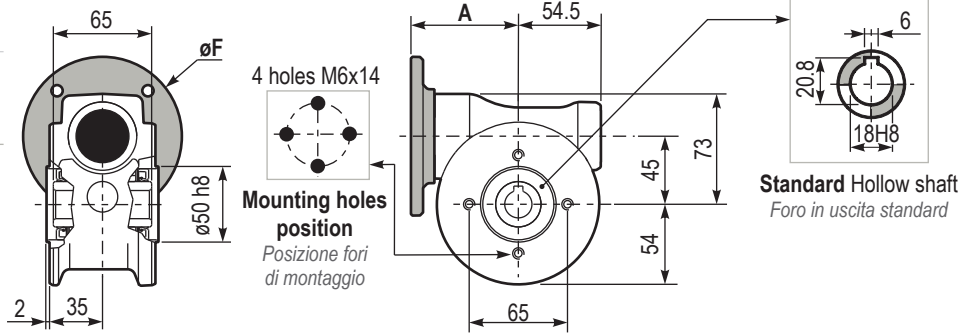

**PZ45PA..** Feet  
*Piedini*

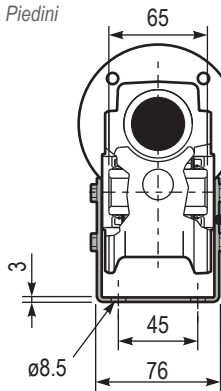

kit cod. KIZ459022

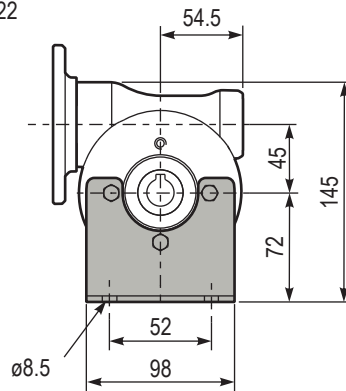

**PZ45PV..** Feet  
*Piedini*

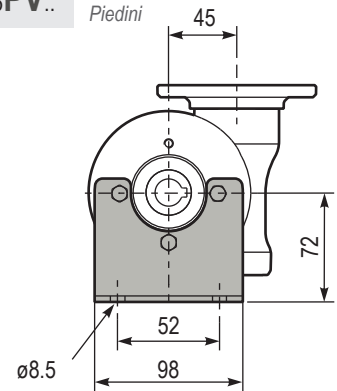

**PZ45FC..** Output flange  
*Flangia uscita*

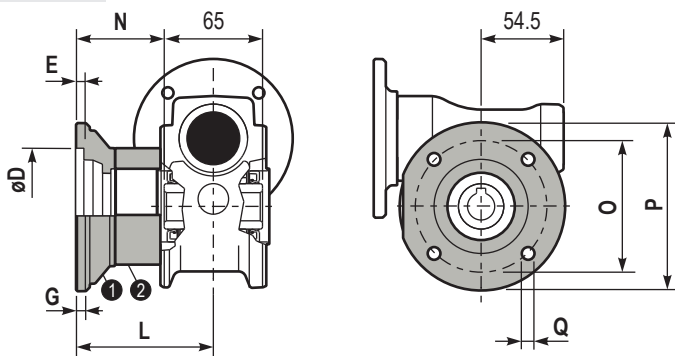

Type	øD	E	G	L	N	O	P	Q	Kit code
FC	60 <sup>+0.15</sup> / <sub>-0.05</sub>	9	9	60.5	28	87	110	8.5	1 KZ459010 2 -
FL	60 <sup>+0.15</sup> / <sub>-0.05</sub>	9	9	90.5	58	87	110	8.5	1 KZ459010 2 KZ450200

**PZ45BR..** Reaction arm  
*Braccio di reazione*

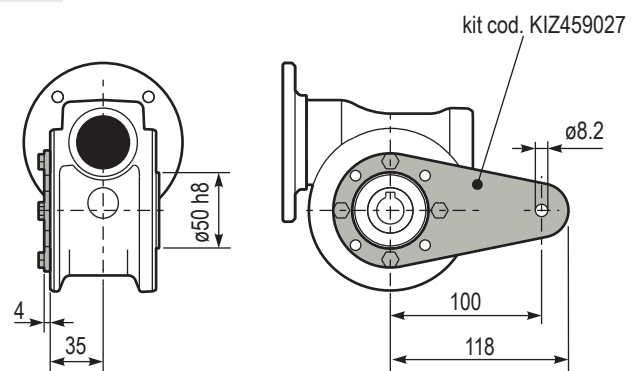

**PZ45..S..** Single output shaft  
*Albero semplice in uscita*

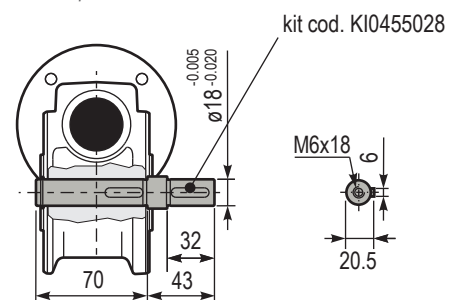

**RZ45UN..** Input shaft  
*Albero in entrata*

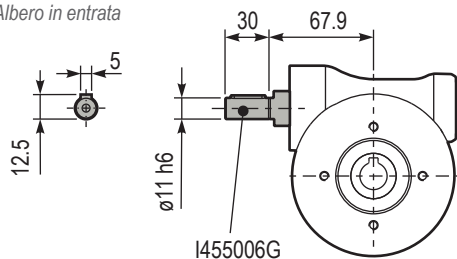

# Z50

# 72 Nm

## VFZ series

# Aluminum worm gearboxes

Riduttori a vite senza fine in alluminio

Input speed ( $n_1$ ) = 1400 min<sup>-1</sup>

Output speed $n_2$ [min <sup>-1</sup> ]	Ratio $i$	Motor power $P_{1M}$ [kW]	Output torque $M_{2M}$ [Nm]	Service factor $f.s$	Nominal power $P_{1R}$ [kW]	Nominal torque $M_{2R}$ [Nm]	B5 motor flanges				B14 motor flanges				Dynamic efficiency RD	Tooth module [mm]	Ratio code
							-	-	-	-	-O	-P	-Q	-R			
200	7	0.75	29	1.9	1.5	57	-	-	-	-	-O	-P	-Q	-R	82	2.5	01
140	10	0.75	41	1.5	1.1	62	-	-	-	-	-O	-P	-Q	-R	80	2.4	02
100	14	0.75	57	1.2	0.90	68	-	-	-	-	-O	-P	-Q	-R	79	2.6	03
78	18	0.55	51	1.2	0.67	62	-	-	-	-	-O	-P	-Q	-R	75	2.0	04
54	26	0.55	67	1.0	0.54	66	-	-	-	-	-O	-P	-Q	-R	69	2.7	05
47	30	0.55	79	0.9	0.50	72	-	-	-	-	-O	-P	-Q	-R	70	2.5	12
39	36	0.37	63	1.2	0.43	72	-	-	-	-	-O	-P	-Q	-R	69	2.1	06
33	43	0.37	72	1.0	0.35	68	-	-	-	-	-O	-P	-Q	-R	66	1.8	07
28	50	0.25	53	1.2	0.31	66	-	-	-	-	-O	-P	-Q	-R	62	1.5	13
23	60	0.25	59	1.0	0.26	62	-	-	-	-	-O	-P	-Q	-R	58	1.3	08
21	68	0.25	66	0.9	0.22	58	-	-	-	-	-O	-P	-Q	-R	57	1.2	09
17.5	80	0.18	53	1.1	0.19	57	-	-	-	-	-O	-P	-Q	-R	54	1.0	10
14	100	0.12	41	1.3	0.15	51	-	-	-	-	-O	-P	-Q	-R	50	0.8	11

Motor flanges available  
Flange motore disponibili



B) Supplied with reduction bushing  
Fornito con bussola di riduzione



B) Available on request without reduction bushing  
Disponibile a richiesta senza bussola di riduzione



C) Motor flange holes position  
Posizione fori flangia motore

## Lubrication

Lubrificazione

Unit Z50 is supplied with synthetic oil to assure long life lubrication. Food grade oil is available on request.

See Table 1 for lubrication and recommended quantity.

See Table 2 for possible radial and axial loads on the gearbox.

Il riduttore tipo Z50 viene fornito con olio sintetico e lubrificazione tipo "long life".

Disponibile a richiesta olio alimentare.

Vedi Tabella 1 per oli e quantità consigliati.

Vedi Tabella 2 per i carichi radiali e assiali applicabili al riduttore.

Oil quantity for all positions:  
0.12Lt.

Quantità olio per tutte le posizioni: 0.12Lt.

Agip  
Telium VSF 320

Shell  
Omala S4 WE 320

## Radial and axial loads

Carichi radiali e assiali

### Output shaft

Albero di uscita

$n_2$ [min <sup>-1</sup> ]	$F_A$ [N]	$F_R$ [N]
200	240	1200
150	280	1400
100	300	1500
75	340	1700
50	380	1900
25	480	2500
15	560	2800

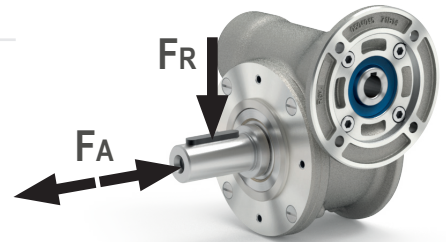

### Input shaft

Albero in entrata

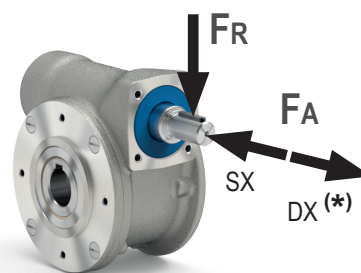

$n_1$ [min <sup>-1</sup> ]	$F_A$ [N]	$F_R$ [N]
1400	76	380

\* Strong axial loads in the DX direction are not allowed.

\* Non sono consentiti forti carichi assiali con direzione DX

Tab. 1

Tab. 2

72  
Nm

Z50

**PZ50UN..** Basic gearbox  
*Riduttore base*

**Gearbox weight** 3.70 kg  
*Peso riduttore*

M. flanges	Kit code	øF	A
56B14	KZ504049	80	76
63B14	KZ504047	90	78.5
71B14	KZ504045	105	76
80B14	KZ504046	120	76.5

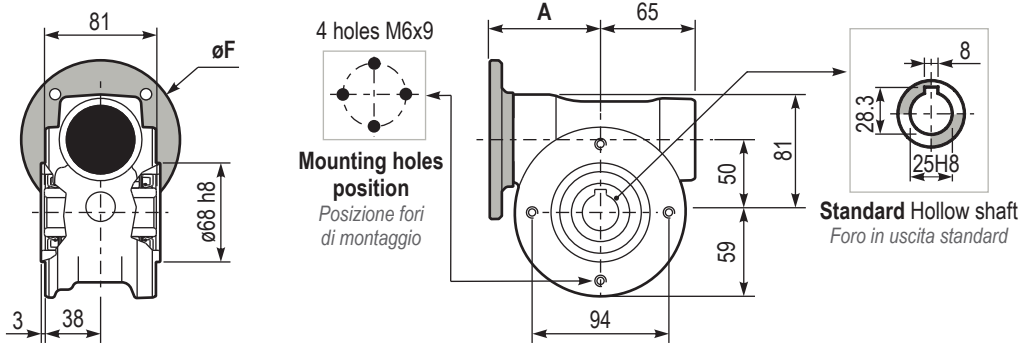

**PZ50PA..** Feet  
*Piedini*

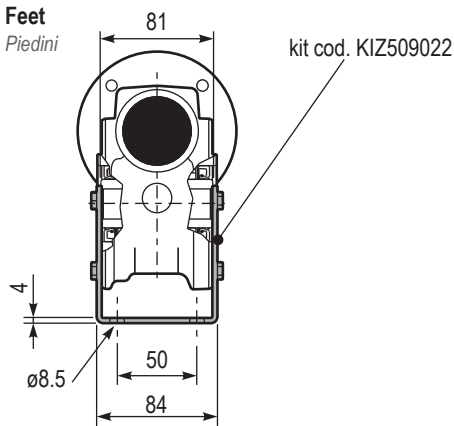

**PZ50PV..** Feet  
*Piedini*

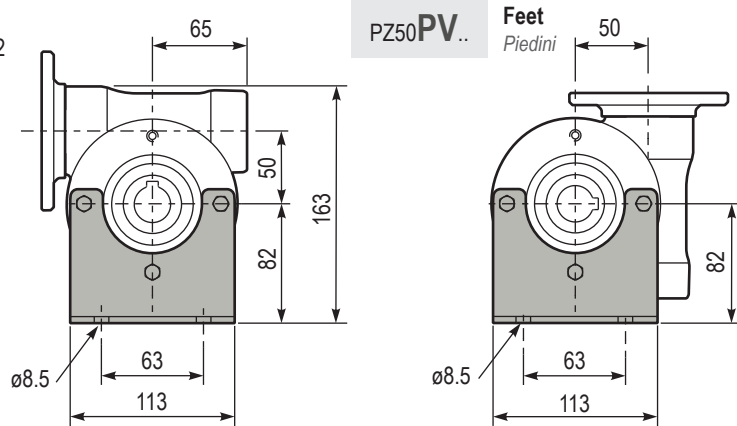

**PZ50FC..** Output flange  
*Flangia uscita*

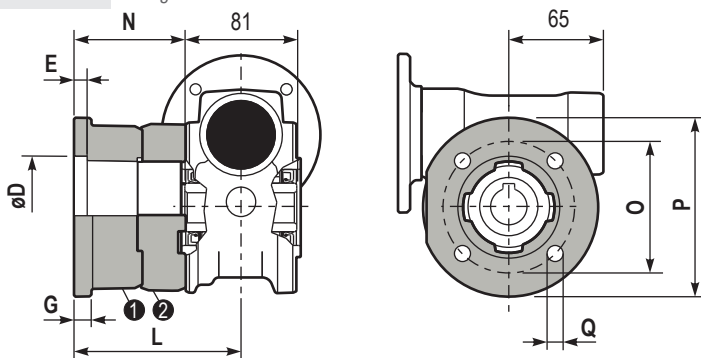

Type	øD	E	G	L	N	O	P	Q	Kit code
FC	70 <sup>+0.20</sup> / <sub>+0.15</sub>	9	12	85	44.5	90	123	10.5	① KZ509010 ② -
FL	70 <sup>+0.20</sup> / <sub>+0.15</sub>	9	12	114.5	74	90	123	10.5	① KZ509010 ② KZ500200

**PZ50BR..** Reaction arm  
*Braccio di reazione*

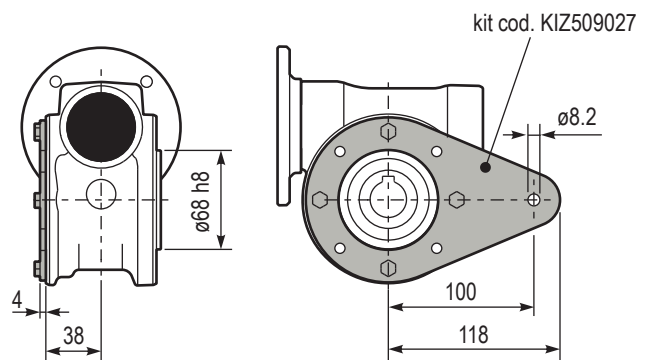

**RZ50UN..** Input shaft  
*Albero in entrata*

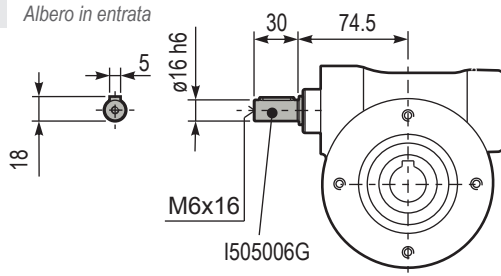

**PZ50..S..** Single output shaft  
*Albero semplice in uscita*

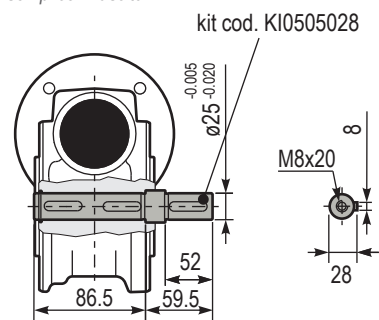

# Z63

# 147 Nm

## VFZ series

# Aluminum worm gearboxes

Riduttori a vite senza fine in alluminio

Input speed ( $n_1$ ) = 1400 min<sup>-1</sup>

Output speed $n_2$ [min <sup>-1</sup> ]	Ratio $i$	Motor power $P_{1M}$ [kW]	Output torque $M_{2M}$ [Nm]	Service factor $f.s$	Nominal power $P_{1R}$ [kW]	Nominal torque $M_{2R}$ [Nm]	B5 motor flanges				B14 motor flanges			Dynamic efficiency RD	Tooth module [mm]	Ratio code
							-	-	-	-	-Q 71	-R 80	-T 90			
200	7	1.8	71	1.8	3.2	125					C	C		83	3.1	01
140	10	1.8	99	1.4	2.4	134					C	C		81	3.1	02
93	15	1.5	121	1.1	1.7	138					C	C		79	3.1	03
74	19	1.1	111	1.2	1.4	138					C	C		78	2.6	04
58	24	1.1	135	1.0	1.2	142					C	C		75	2.0	05
47	30	1.1	167	0.9	0.96	146					C	C		74	3.2	06
39	36	0.75	125	1.2	0.88	147					C	C		68	2.7	07
35	40	0.75	135	1.0	0.78	140					C	C		66	2.5	13
31	45	0.55	111	1.2	0.67	135					C	C		66	2.1	08
23	60	0.55	140	0.9	0.51	130					C	C		62	1.6	12
21	67	0.55	151	0.8	0.45	124					C	C		60	1.5	09
17.5	80	0.37	115	1.0	0.38	119					C	C		57	1.3	10
14.9	94	0.37	123	1.0	0.36	119					C	C		52	1.1	11

Motor flanges available  
Flange motore disponibili



B) Supplied with reduction bushing  
Fornito con bussola di riduzione



B) Available on request without reduction bushing  
Disponibile a richiesta senza bussola di riduzione



C) Motor flange holes position  
Posizione fori flangia motore

## Lubrication

Lubrificazione

Unit Z63 is supplied with synthetic oil to assure long life lubrication.  
Food grade oil is available on request.

See Table 1 for lubrication and recommended quantity.

See Table 2 for possible radial and axial loads on the gearbox.

Il riduttore tipo Z63 viene fornito con olio sintetico e lubrificazione tipo "long life".

Disponibile a richiesta olio alimentare.

Vedi Tabella 1 per oli e quantità consigliati.

Vedi Tabella 2 per i carichi radiali e assiali applicabili al riduttore.

Oil quantity for  
all positions:  
0.30Lt.

Quantità olio per tutte  
le posizioni: 0.30Lt.

Agip  
Telium VSF 320

Shell  
Omala S4 WE 320

## Radial and axial loads

Carichi radiali e assiali

### Output shaft

Albero di uscita

$n_2$ [min <sup>-1</sup> ]	$F_A$ [N]	$F_R$ [N]
200	360	1800
150	400	2000
100	460	2300
75	500	2500
50	600	3000
25	700	3800
15	800	4000

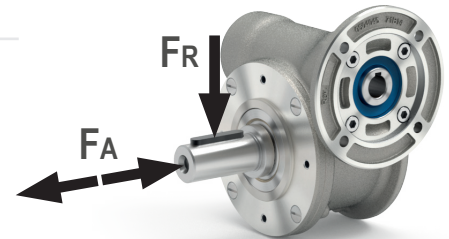

### Input shaft

Albero in entrata

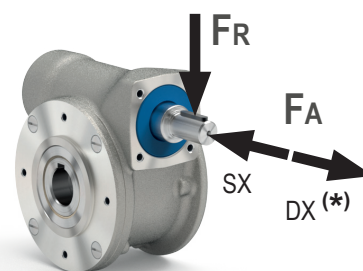

$n_1$ [min <sup>-1</sup> ]	$F_A$ [N]	$F_R$ [N]
1400	90	450

\* Strong axial loads in the DX direction are not allowed.

\* Non sono consentiti forti carichi assiali con direzione DX

Tab. 1

Tab. 2

147  
Nm

Z63

**PZ63UN..** Basic gearbox  
*Riduttore base*

**Gearbox weight**  
*Peso riduttore* 6.70 kg

M. flanges	Kit code	øF	A
71B14	KZ634047	105	97.5
80B14	KZ634046	120	99.5
90B14	KZ634041	140	99.5

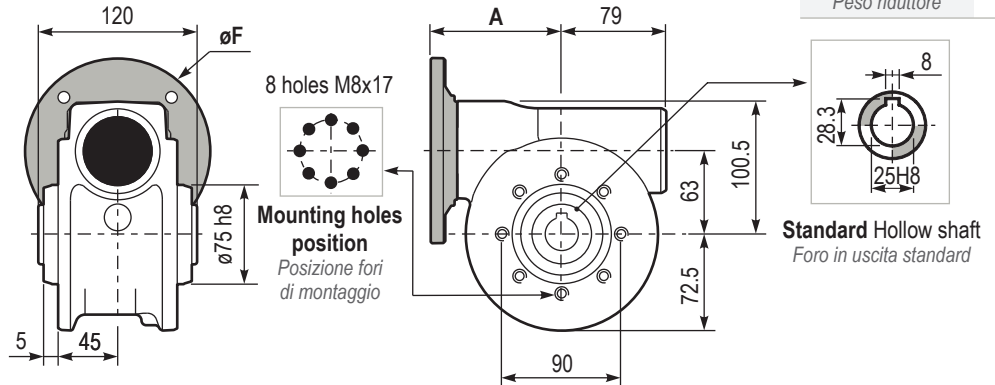

**PZ63PA..** Feet  
*Piedini*

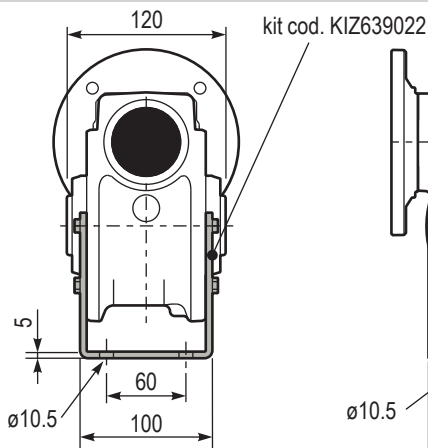

**PZ63PV..** Feet  
*Piedini*

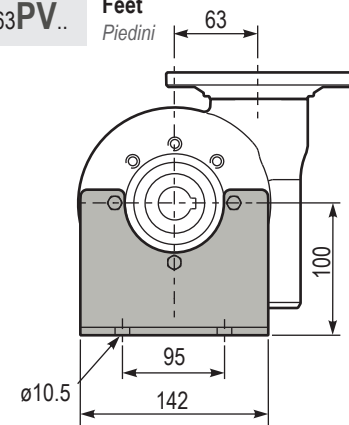

**PZ63FC..** Output flange  
*Flangia uscita*

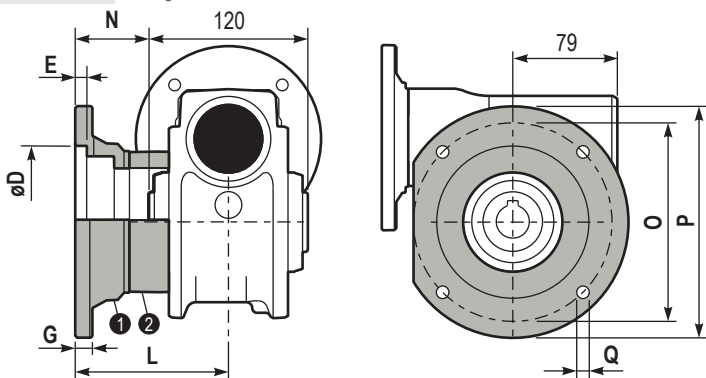

**PZ63BR..** Reaction arm  
*Braccio di reazione*

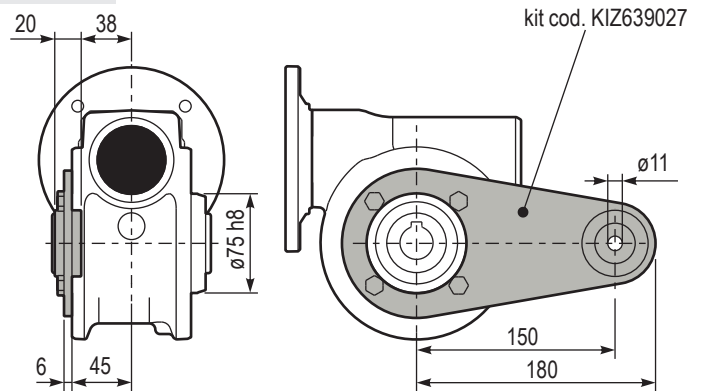

Type	øD	E	G	L	N	O	P	Q	Kit code
FC	115 <sup>+0.20</sup> <sub>-0.15</sub>	7	13	86	26	150	175	11	① KZ639010 ② -
FL	115 <sup>+0.20</sup> <sub>-0.15</sub>	7	13	116	56	150	175	11	① KZ639010 ② KZ630200

**RZ63UN..** Input shaft  
*Albero in entrata*

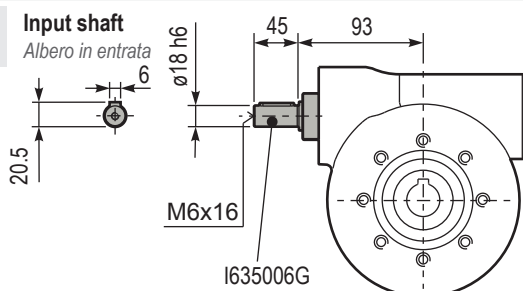

**PZ63..S..** Single output shaft  
*Albero semplice in uscita*

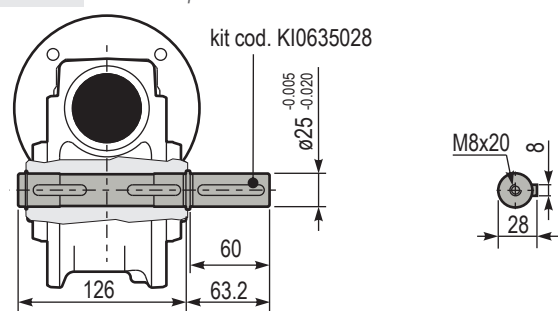

# Z85

# 347 Nm

## VFZ series Aluminum worm gearboxes

Riduttori a vite senza fine in alluminio

Input speed ( $n_1$ ) = 1400 min<sup>-1</sup>

Output speed $n_2$ [min <sup>-1</sup> ]	Ratio $i$	Motor power $P_{1M}$ [kW]	Output torque $M_{2M}$ [Nm]	Service factor $f_s$	Nominal power $P_{1R}$ [kW]	Nominal torque $M_{2R}$ [Nm]	B5 motor flanges				B14 motor flanges			Dynamic efficiency RD	Tooth module [mm]	Ratio code
							-	-	-	-	-R	-T	-U			
200	7	4.0	168	1.5	6.1	257								88	4.23	01
140	10	4.0	218	1.3	5.2	284								80	4.2	02
100	14	3.0	223	1.4	4.1	305								78	4.5	03
70	20	2.2	237	1.2	2.7	294								79	3.4	04
64	22	2.2	258	1.1	2.5	294								78	3.1	05
50	28	2.2	315	1.1	2.4	347								75	4.7	06
37	38	1.5	276	1.2	1.8	336								71	3.5	07
30	46	1.5	320	1.0	1.5	326								68	3.1	08
27	52	1.1	258	1.1	1.2	289								66	2.7	09
21	67	1.1	327	0.9	0.97	289								65	2.1	10
18.9	74	0.75	220	1.2	0.91	268								58	1.9	11
14.6	96	0.55	191	1.3	0.70	242								53	1.5	12

Motor flanges available  
Flange motore disponibili

B) Supplied with reduction bushing  
Fornito con bussola di riduzione

B) Available on request without reduction bushing  
Disponibile a richiesta senza bussola di riduzione

C) Motor flange holes position  
Posizione fori flangia motore

### Lubrication

Lubrificazione

Unit Z85 is supplied with synthetic oil to assure long life lubrication.  
Food grade oil is available on request.

See Table 1 for lubrication and recommended quantity.

See Table 2 for possible radial and axial loads on the gearbox.

Il riduttore tipo Z85 viene fornito con olio sintetico e lubrificazione tipo "long life".

Disponibile a richiesta olio alimentare.

Vedi Tabella 1 per oli e quantità consigliati.

Vedi Tabella 2 per i carichi radiali e assiali applicabili al riduttore.

Oil quantity for  
all positions:  
0.95Lt.

Quantità olio per tutte  
le posizioni: 0.95Lt.

**Agip**  
Telium VSF 320

**Shell**  
Omala S4 WE 320

### Radial and axial loads

Carichi radiali e assiali

#### Output shaft

Albero di uscita

$n_2$ [min <sup>-1</sup> ]	$F_A$ [N]	$F_R$ [N]
200	500	2500
150	580	2900
100	600	3000
75	700	3500
50	800	4000
25	1000	5000
15	1160	5800

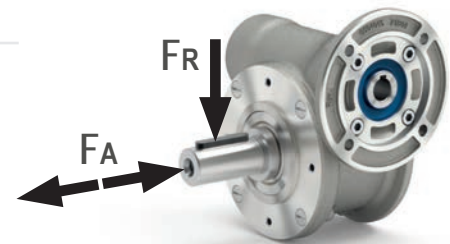

#### Input shaft

Albero in entrata

$n_1$ [min <sup>-1</sup> ]	$F_A$ [N]	$F_R$ [N]
1400	130	650

\* Strong axial loads in the DX direction are not allowed.

\* Non sono consentiti forti carichi assiali con direzione DX

Tab. 1

Tab. 2

347  
Nm

Z85

PZ85UN.. Basic gearbox  
Riduttore base

Gearbox weight 13.00 kg  
Peso riduttore

M. flanges	Kit code	øF	A
80B14	KZ854046	120	118.5
90B14	KZ854045	140	118.5
100/112B14	KZ854047	160	127.5

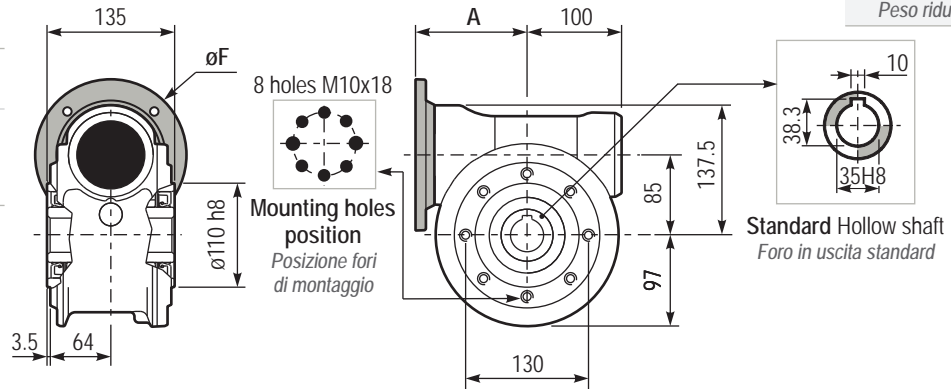

PZ85PA.. Feet  
Piedini

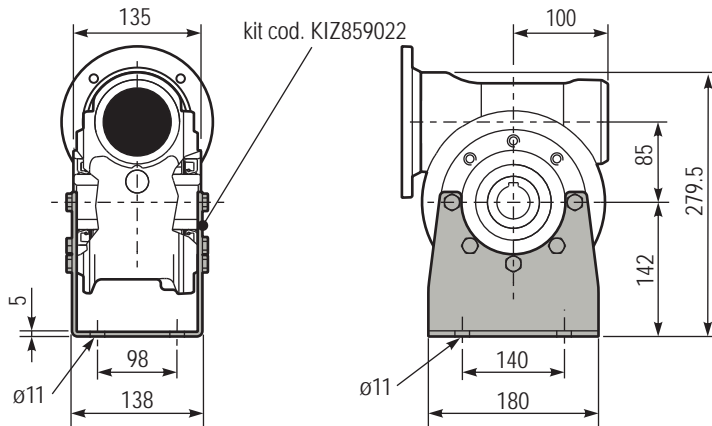

PZ85PV.. Feet  
Piedini

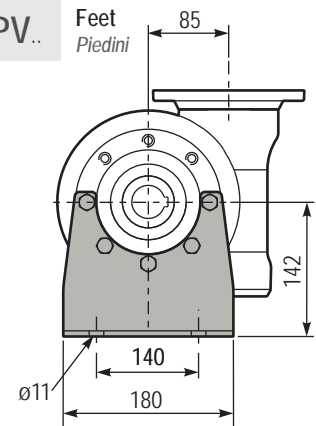

PZ85FC.. Output flange  
Flangia uscita

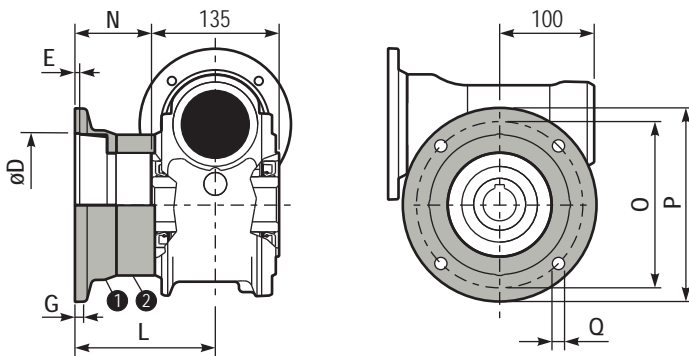

Type	øD	E	G	L	N	O	P	Q	Kit code
FC	152 <sup>+0.06</sup> <sub>-0.00</sub>	5	16	108	40.5	176	205	13	● KZ859010 ●
FL	152 <sup>+0.06</sup> <sub>-0.00</sub>	5	16	148.5	81	176	205	13	● KZ859010 ● KZ850201

PZ85BR.. Reaction arm  
Braccio di reazione

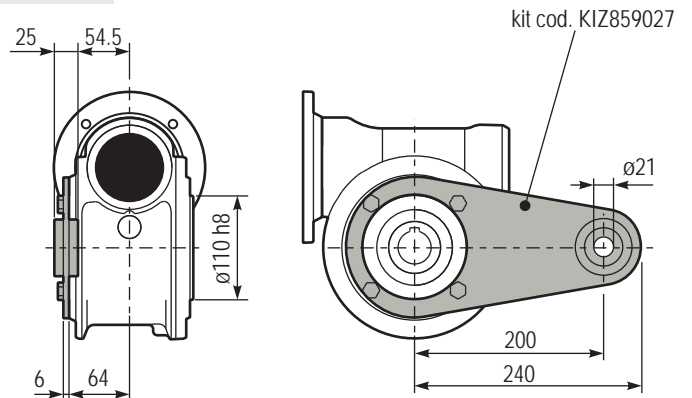

RZ85UN.. Input shaft  
Albero in entrata

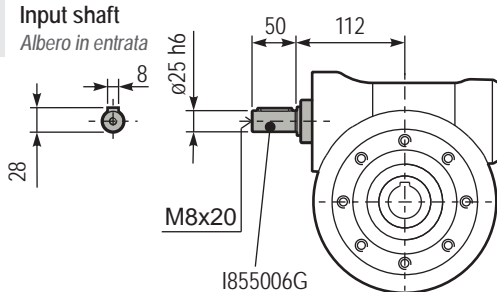

PZ85..S.. Single output shaft  
Albero semplice in uscita

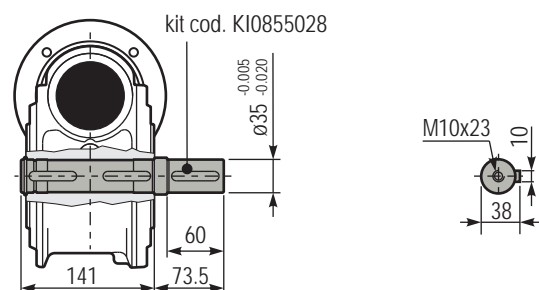





**z** RCZ series  
Aluminum ratio multipliers

*Riduttori ad uno stadio in alluminio*

Section **2**  
Sezione 2

This range is



certified

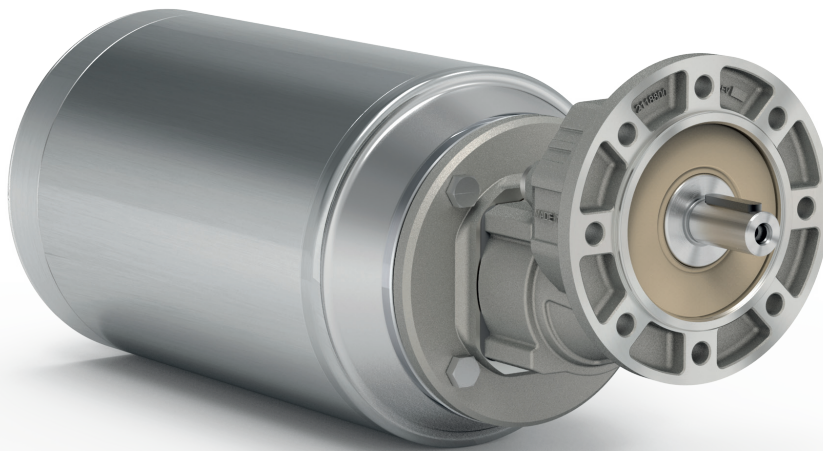

# FEATURES

Caratteristiche

## RCZ series Aluminum ratio multipliers

Riduttori ad uno stadio in alluminio

Type <i>Tipo</i>	Torque <i>Coppia</i>	Center distance <i>Interasse</i>	Input power <i>Potenza in entrata</i>	Output shaft <i>Albero in uscita</i>
211Z	20 Nm	30 mm	0.25 ÷ 0.37 kW	ø14 mm

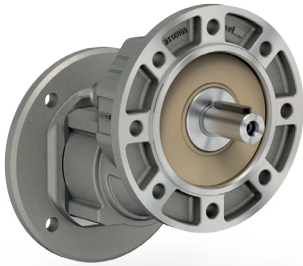

This product is:

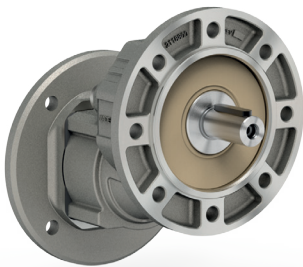

**Stainless steel output shaft.**

*Albero in uscita in acciaio inox.*

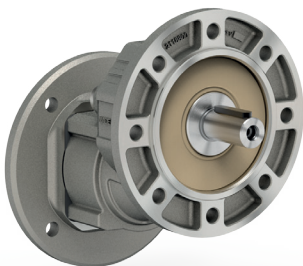

**NTT™ stands for a special surface treatment which results in modified external properties of the complete unit in order to get a smooth surface and an higher corrosion resistance.**

*NTT™ è uno speciale trattamento che come risultato ha la modifica delle proprietà superficiali del riduttore allo scopo di ottenere una superficie liscia e con maggiore resistenza alla corrosione.*

# FEATURES

*Caratteristiche*

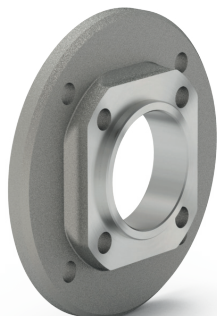

**Fully modular IEC flanges and compact NEMA C motor flanges.**

*Flange IEC e NEMA completamente modulari.*

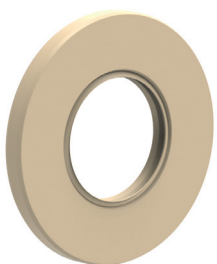

**Standard FPM (fkm) seals are used, since seals will be in a closed area.**

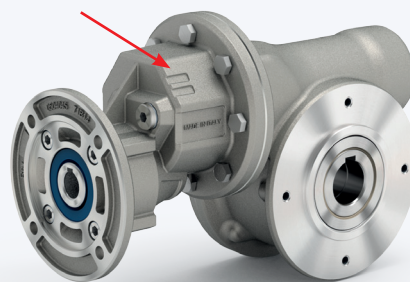

*Anelli di tenuta FPM(fkm) standard.*













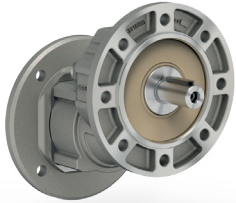

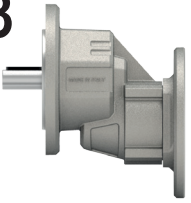

**Hardened and ground gears.**

*Ingranaggi temprati e rettificati.*

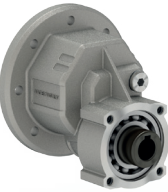
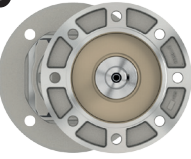
# How to order

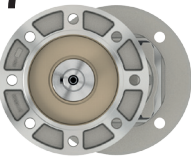
Codifica

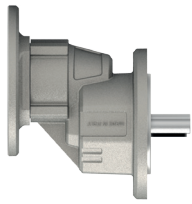
<b>P</b>	<b>211Z</b>	<b>-F</b>	<b>2.05</b>	<b>S</b>
Type <i>Tipo</i>	Size <i>Grandezza</i>	Mounting <i>Montaggio</i>	Ratio <i>Rapporto</i>	Output shaft <i>Albero lento</i>
<b>P</b> 	<b>211Z</b>	<b>-F</b> 	See technical data table <i>Vedi tabelle dati tecnici</i>	
<b>M</b> 				<b>S</b> -> ø14
<b>B</b> 				

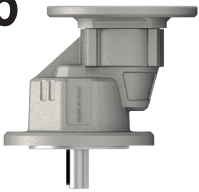
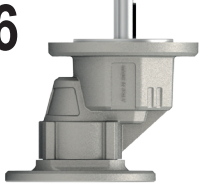
I	-Q	B3	-	With Type M specify terminal box position Con tipo M specificare posizione morsettiera
Output flange Flangia uscita	Motor size Grandezza motore	Mounting position Posizione di montaggio	Input bore Foro entrata	Terminal box position Posizione morsettiera
 <p>I -&gt; <math>\varnothing 105</math></p>	<p><b>Flange</b> Flange</p>  <p><b>IEC B14</b></p> <ul style="list-style-type: none"> <li>-O -&gt; 56 B14 (<math>\varnothing 80</math>)</li> <li>-P -&gt; 63 B14 (<math>\varnothing 90</math>)</li> <li>-Q -&gt; 71 B14 (<math>\varnothing 105</math>)</li> </ul>	<p><b>B3</b></p> 	<p>- <b>Standard bore</b> Foro standard</p>	<p><b>A</b></p> 
	<p><b>Without flange</b> Senza flangia</p>  <p><b>211Z</b></p> <ul style="list-style-type: none"> <li>-Z -&gt; <math>\varnothing 9</math> (56 B5)</li> <li>-0 -&gt; <math>\varnothing 11</math> (63 B5)</li> <li>-1 -&gt; <math>\varnothing 14</math> (71 B5)</li> </ul>	<p><b>B6</b></p> 		<p><b>B</b></p> 
		<p><b>B7</b></p> 		<p><b>C</b></p> 
		<p><b>B8</b></p> 		<p><b>D</b></p> 
		<p><b>V5</b></p> 		
		<p><b>V6</b></p> 		

# Useful formulas

Formule utili

## Required power - Potenza richiesta

Lifting - Sollevamento

Rotation - Rotazione

Linear movement - Traslazione

$$P_{[kW]} = \frac{M_{[Kg]} \cdot g_{[9.81]} \cdot v_{[m/s]}}{1000}$$

$$P_{[kW]} = \frac{M_{[Nm]} \cdot n_{[rpm]}}{9550}$$

$$P_{[kW]} = \frac{F_{[N]} \cdot v_{[m/s]}}{1000}$$

## Torque - Coppia

$$M_{[Nm]} = \frac{9550 \cdot P_{[kW]}}{n_{[rpm]}}$$

$$M_{[lb\ in]} = \frac{63030 \cdot P_{[HP]}}{n_{[rpm]}}$$

## Radial loads - Carichi radiali

**Radial load generated by external transmissions keyed onto input and/or output shafts.**

Forza radiale generata da organi di trasmissione calettati sugli alberi di ingresso e/o uscita.

$$F_{R[N]} = \frac{M_{[Nm]} \cdot 2000}{d_{[mm]}} \cdot f_k$$

$$F_{R[N]} = \frac{M_{[lb\ in]} \cdot 8.9}{d_{[in]}} \cdot f_k$$

**M:** Output torque - *Momento torcente*

**d:** Diam. of driving element - *Diametro primitivo*

**f<sub>k</sub>:** Factor - *Coefficiente di trasformazione*

**1.15:** Gearwheels - *Ingranaggi*

**1.25:** Chain sprochets - *Catena*

**1.75:** Narrow v-belt pulley - *Cinghia Trapezoidale*

**2.50:** Flat-belt pulley - *Cinghia piatta*

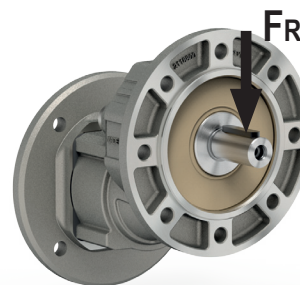

**If your application requires higher radial loads, contact our technical office. Higher loads may be possible.**

Nel caso la vostra applicazione richieda carichi radiali superiori consultare il nostro ufficio tecnico, valori maggiori possono essere accettati.

# How to select a gearbox

Come selezionare un riduttore

## A Select required torque (according to service factor)

Seleziona la coppia desiderata (comprensiva del fattore di servizio)

## B Select output speed

Seleziona la velocità in uscita

## C Select gear ratio in the line corresponding to the chosen motor power

Sulla riga corrispondente alla motorizzazione prescelta si può rilevare il rapporto di riduzione

## D Select motor flange available (if requested)

Scegli la flangia disponibile (se richiesta)

Gear size  
Grandezza  
riduttore

C

Ratio  
Rapporto

Transmitted torque  
Momento torcente  
trasmesso

Nominal power  
Potenza nominale

Flange code  
Codice flangia

Input speed  
Velocità in entrata

211Z



20  
Nm

## RCZ series Aluminum ratio multipliers

Riduttori ad uno stadio in alluminio

The dynamic efficiency is **0.98** for all ratios

Input speed ( $n_1$ ) = 1400 min<sup>-1</sup>

Output speed $n_2$ [min <sup>-1</sup> ]	Ratio $i$	Motor power $P_{1M}$ [kW]	Output torque $M_{2M}$ [Nm]	Service factor f.s	Nominal power $P_{1R}$ [kW]	Nominal torque $M_{2R}$ [Nm]	B5 motor flanges			B14 motor flanges			Output shaft 	Ratios code 
							-B 63	-C 71	-O 71	-P 80	-Q 90			
682	<b>2.05</b>	0.37	5	2.0	<b>0.73</b>	<b>10</b>			C	C		1939	01	
595	<b>2.35</b>	0.37	6	2.1	<b>0.76</b>	<b>12</b>			C	C		1740	02	
500	<b>2.80</b>	0.37	7	2.0	<b>0.75</b>	<b>14</b>			C	C		1542	03	
414	<b>3.38</b>	0.37	8	2.0	<b>0.75</b>	<b>17</b>			C	C		1344	04	
298	<b>4.70</b>	0.37	12	1.7	<b>0.64</b>	<b>20</b>			C	C	standard ø14	1047	05	
225	<b>6.22</b>	0.37	15	1.5	<b>0.55</b>	<b>23</b>			C	C		956	06	
169	<b>8.29</b>	0.37	20	1.0	<b>0.36</b>	<b>20</b>			C	C		758	07	
142	<b>9.83</b>	0.25	16	1.0	<b>0.24</b>	<b>16</b>			C	C		659	08	

B Output speed  
Velocità in uscita

Motor power  
Potenza motore

Service factor  
Fattore di servizio

A Nominal torque  
Momento torcente  
nominale

Output shaft diam.  
Diametro albero uscita

Notes  
Note

### Type of load and starts per hour

Tipo di carico e avviamenti per ora

Oper. hours per day  
Ore di funz. giorn.

		Oper. hours per day		
		3h	10h	24h
Continuous or intermittent application with start / hour <i>Applicazione continua o intermittente con numero operazioni/ora</i>	Uniform - <i>Uniforme</i>	0.8	1	1.25
	Moderate - <i>Moderato</i>	1	1.25	1.5
	Heavy - <i>Forte</i>	1.25	1.5	1.75
Intermittent application with start / hour <i>Applicazione intermittente con numero operazioni/ora</i>	Uniform - <i>Uniforme</i>	1	1.25	1.5
	Moderate - <i>Moderato</i>	1.25	1.5	1.75
	Heavy - <i>Forte</i>	1.5	1.75	2.15

D Motor flange available  
Flange disponibili

B) Mounting with reduction bushing  
*Montaggio con boccia di riduzione*

C) Motor flange holes position/terminal box position  
*Posizione fori flangia/basetta motore*

B) Available without reduction bushing  
*Disponibile anche senza boccia*

# 211Z



## 20 Nm

# RCZ series Aluminum ratio multipliers

Riduttori ad uno stadio in alluminio

The dynamic efficiency is **0.98** for all ratios

Input speed ( $n_1$ ) = 1400 min<sup>-1</sup>

Output speed $n_2$ [min <sup>-1</sup> ]	Ratio $i$	Motor power $P_{1M}$ [kW]	Output torque $M_{2M}$ [Nm]	Service factor $f_s$	Nominal power $P_{1R}$ [kW]	Nominal torque $M_{2R}$ [Nm]	B5 motor flanges			B14 motor flanges			Output shaft 	Ratios code 
							-	-	-	-O	-P	-Q		
682	2.05	0.37	5	2.0	0.73	10				C	C		1939	01
595	2.35	0.37	6	2.1	0.76	12				C	C		1740	02
500	2.80	0.37	7	2.0	0.75	14				C	C		1542	03
414	3.38	0.37	8	2.0	0.75	17				C	C		1344	04
298	4.70	0.37	12	1.7	0.64	20				C	C	standard ø14	1047	05
225	6.22	0.37	15	1.5	0.55	23				C	C		956	06
169	8.29	0.37	20	1.0	0.36	20				C	C		758	07
142	9.83	0.25	16	1.0	0.24	16				C	C		659	08

**Motor flanges available**  
Flange motore disponibili

 **B) Supplied with reduction bushing**  
Fornito con bussola di riduzione

**B) Available on request without reduction bushing**  
Disponibile a richiesta senza bussola di riduzione

 **C) Motor flange holes position**  
Posizione fori flangia motore

## Lubrication

Lubrificazione

Unit 211Z is supplied with synthetic oil to assure long life lubrication. Food grade oil is available on request.

See Table 1 for lubrication and recommended quantity.

See Table 2 for possible radial and axial loads on the gearbox.

Il riduttore tipo 211Z viene fornito con olio sintetico e lubrificazione tipo "long life".

Disponibile a richiesta olio alimentare.

Vedi Tabella 1 per oli e quantità consigliati.

Vedi Tabella 2 per i carichi radiali e assiali applicabili al riduttore.

**Oil quantity for all positions:**  
**0.05Lt.**

Quantità olio per tutte le posizioni: 0.05Lt

**Agip**  
Telium VSF 320

**Shell**  
Omala S4 WE 320

## Radial and axial loads

Carichi radiali e assiali

### Output shaft

Albero di uscita

$n_2$ [min <sup>-1</sup> ]	$F_A$ [N]	$F_R$ [N]
700	101	504
600	120	600
400	138	696
300	151	756
200	175	876
140	192	960

$$F_{eq} = F_R \cdot \frac{34.5}{X + 19.5}$$

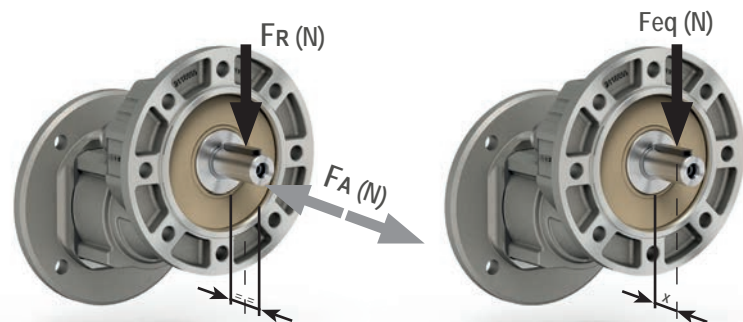

Tab. 1

Tab. 2



20  
Nm

211Z

P211Z-F ...

Basic gearbox  
Riduttore base

Gearbox weight  
Peso riduttore

1.40 kg

M. flanges	Kit code	k1	øF
56 B14	KZ504049	97	80
63 B14	KZ504047	99.5	90
71 B14	KZ504045	97	105

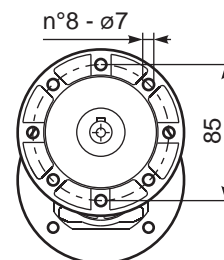
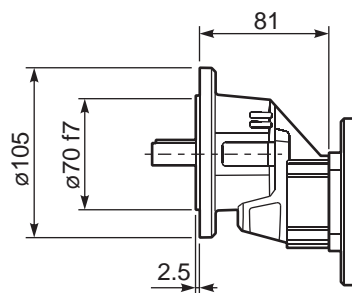
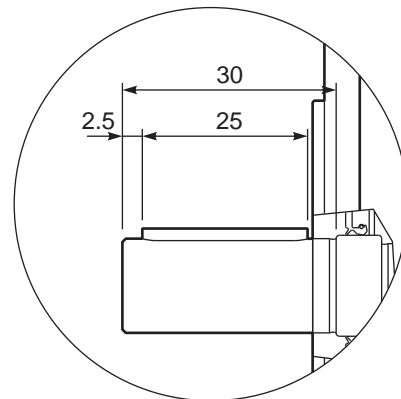
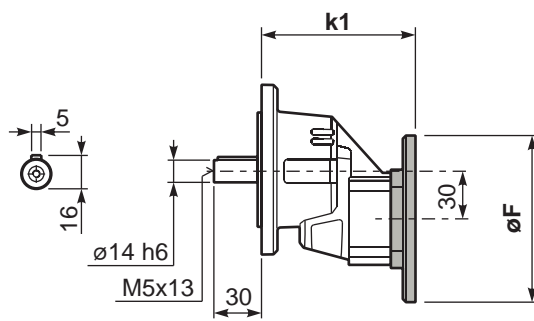



# L VFL series Stainless steel shielded worm gearboxes

*Riduttori a vite senza fine schermati in acciaio inox*

Section **3**  
Sezione 3

This range is    certified

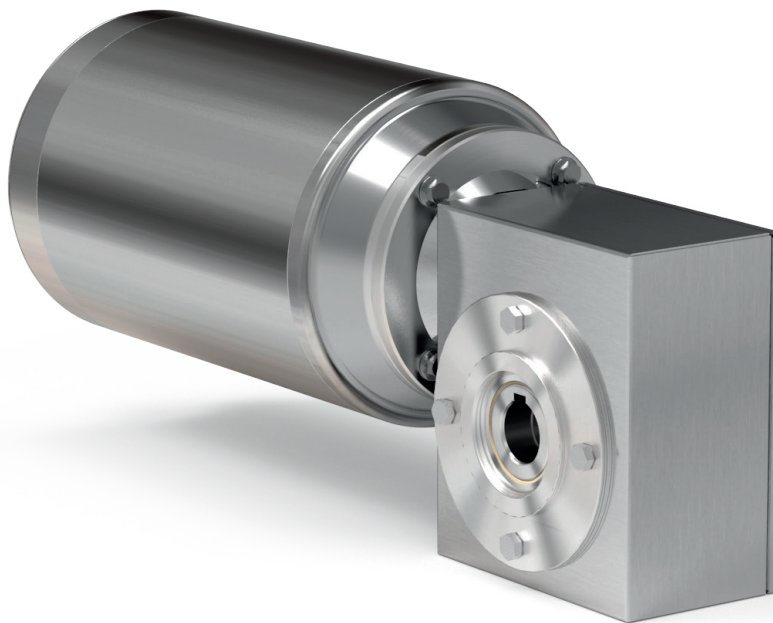

# FEATURES

Caratteristiche

## VFL series Stainless steel shielded worm gearboxes

Riduttori a vite senza fine schermati in acciaio inox

Type <i>Tipo</i>	Torque <i>Coppia</i>	Center distance <i>Interasse</i>	Input power <i>Potenza in entrata</i>	Hollow output shaft <i>Albero cavo in uscita</i>
LD45	41 Nm	45 mm	0.12 ÷ 0.37 kW	ø18 mm
LD50	72 Nm	50 mm	0.12 ÷ 0.75 kW	ø25 mm
LD63	147 Nm	63 mm	0.37 ÷ 1.8 kW	ø25 mm
LD85	347 Nm	85 mm	0.55 ÷ 4.0 kW	ø35 mm

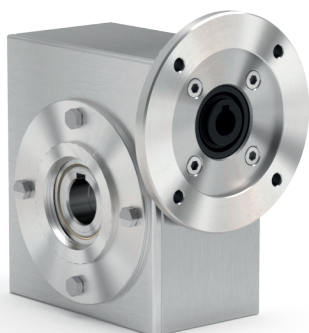

This product is:

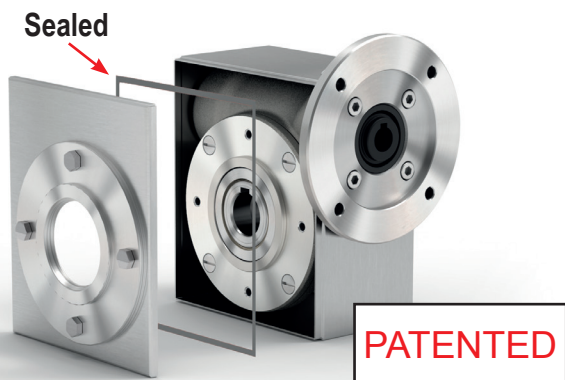

The "L" series is an already totally enclosed aluminum gearboxes, that is shielded and sealed by stainless steel 316L case.

La serie "L" è ottenuta da un riduttore in alluminio che viene incapsulato all'interno di un carter sigillato in inox 316L.

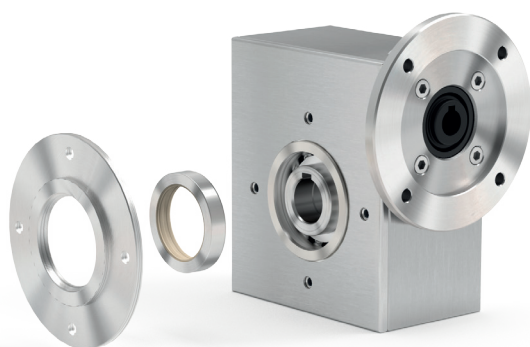

Twin viton seals with stainless steel 316L shield.



Doppio anello di tenuta in viton con schermo protettivo in acciaio inox AISI 316L.

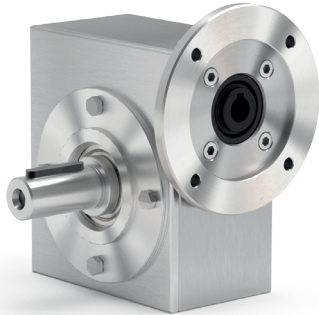

**Output shaft is produced in AISI 316L.**

*Albero in uscita in AISI 316L.*

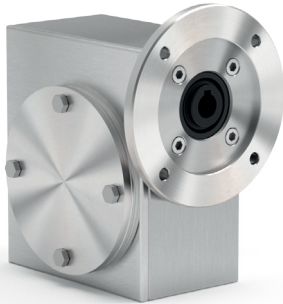

**Protection cap in AISI 316L.**

*Coperchietto di protezione in AISI 316L.*











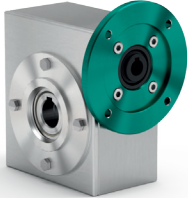
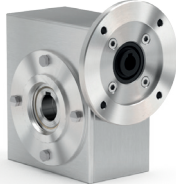
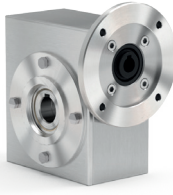

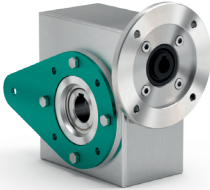

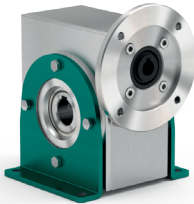
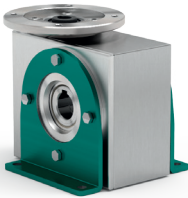
**CuSn12Ni (C91700) Nickel bronze worm gears are centrifugally cast onto an iron hub for maximum strength and superior life. Removable hollow shaft with key for safe torque transmissions.**

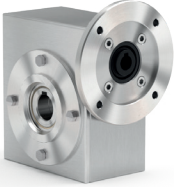
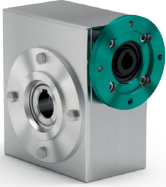
*Corona in bronzo al Nickel CuSn12Ni (C91700) centrifugato e mozzo in acciaio inox per massima resistenza e durata superiore. Albero cavo removibile con chiavetta mozzo/corona.*

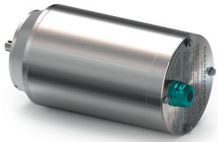
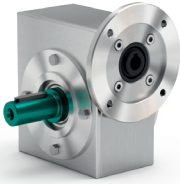
# How to order

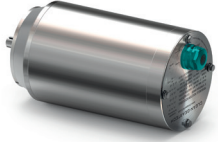
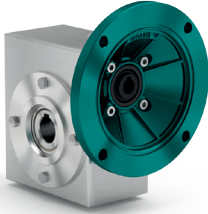
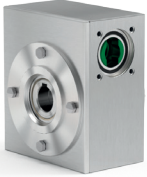
Codifica

<b>P</b>	<b>LD50</b>	<b>UN</b>	<b>10</b>	<b>I</b>
Type <i>Tipo</i>	Size <i>Grandezza</i>	Mounting <i>Montaggio</i>	Ratio <i>Rapporto</i>	Hub <i>Mozzo corona</i>
<b>P</b> 	<b>LD45</b> <b>LD50</b> <b>LD63</b> <b>LD85</b>	<b>UN</b> 	See technical data table <i>Vedi tabelle dati tecnici</i>	<b>I</b> 
<b>M</b> 		<b>BR</b> 		LD45 -> $\varnothing 18$ LD50 -> $\varnothing 25$ LD63 -> $\varnothing 25$ LD85 -> $\varnothing 35$
<b>B</b> 		<b>PA</b> 		<b>Z</b> Inch LD45 -> $\varnothing 0.750''$ LD50 -> $\varnothing 1.000''$ LD63 -> $\varnothing 1.125''$ LD85 -> $\varnothing 1.500''$
		<b>PV</b> 		

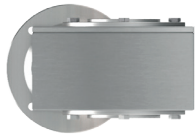
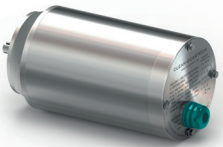
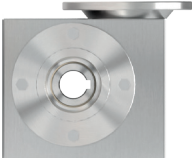
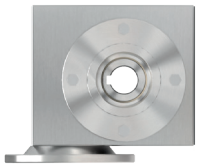
<b>S</b>	<b>-R</b>	<b>B3</b>	<b>D</b>	With Type M specify terminal box position <i>Con tipo M specificare posizione morsettiera</i>
Output shaft <i>Albero lento</i>	Motor size <i>Grandezza motore</i>	Mounting position <i>Posizione di montaggio</i>	Input bore <i>Foro entrata</i>	Terminal box position <i>Posizione morsettiera</i>
<p>Ø</p> 	<p><b>Flange</b> <i>Flange</i></p> 	<p><b>B3</b></p> 	<p><b>With coupling</b> <i>Con giunto</i></p> 	<p><b>A</b></p> 
<p><b>S</b></p> 	<p><b>IEC B14</b></p> <ul style="list-style-type: none"> <li>-P -&gt; 63 B14 (ø90)</li> <li>-Q -&gt; 71 B14 (ø105)</li> <li>-R -&gt; 80 B14 (ø120)</li> <li>-T -&gt; 90 B14 (ø140)</li> <li>-U -&gt; 100-112 B14 (ø160)</li> </ul>	<p><b>B8</b></p> 	<p><b>B</b> -&gt; 11mm  <b>C</b> -&gt; 14mm  <b>D</b> -&gt; 19mm  <b>E</b> -&gt; 24mm  <b>F</b> -&gt; 28mm  <b>W</b> -&gt; ø0.625"  <b>X</b> -&gt; ø0.875"  <b>Y</b> -&gt; ø1.125"</p>	<p><b>B</b></p> 
<p><b>NEMA</b></p> 	<p><b>Without flange</b> <i>Senza flangia</i></p>  <ul style="list-style-type: none"> <li>-W -&gt; 56C (ø6.5")</li> <li>-X -&gt; 143/5TC (ø6.5")</li> <li>-Y -&gt; 182/4TC (ø8.88")</li> </ul>	<p><b>B6</b></p> 	<p><b>0 Ready for input coupling</b> <i>Predisposto per giunto</i></p> 	<p><b>C</b></p> 
<p><b>-M</b> -&gt; Metric <b>-N</b> -&gt; Nema</p>		<p><b>B7</b></p> 		<p><b>D</b></p> 
		<p><b>V5</b></p> 		
		<p><b>V6</b></p> 		

# Useful formulas

Formule utili

## Required power - Potenza richiesta

Lifting - Sollevamento

Rotation - Rotazione

Linear movement - Traslazione

$$P_{[kW]} = \frac{M_{[Kg]} \cdot g_{[9.81]} \cdot v_{[m/s]}}{1000}$$

$$P_{[kW]} = \frac{M_{[Nm]} \cdot n_{[rpm]}}{9550}$$

$$P_{[kW]} = \frac{F_{[N]} \cdot v_{[m/s]}}{1000}$$

## Torque - Coppia

$$M_{[Nm]} = \frac{9550 \cdot P_{[kW]}}{n_{[rpm]}}$$

$$M_{[lb\ in]} = \frac{63030 \cdot P_{[HP]}}{n_{[rpm]}}$$

## Radial loads - Carichi radiali

**Radial load generated by external transmissions keyed onto input and/or output shafts.**

Forza radiale generata da organi di trasmissione calettati sugli alberi di ingresso e/o uscita.

$$F_{R[N]} = \frac{M_{[Nm]} \cdot 2000}{d_{[mm]}} \cdot f_k$$

$$F_{R[N]} = \frac{M_{[lb\ in]} \cdot 8.9}{d_{[in]}} \cdot f_k$$

**M:** Output torque - *Momento torcente*

**d:** Diam. of driving element - *Diametro primitivo*

**f<sub>k</sub>:** Factor - *Coefficiente di trasformazione*

**1.15:** Gearwheels - *Ingranaggi*

**1.25:** Chain sprochets - *Catena*

**1.75:** Narrow v-belt pulley - *Cinghia Trapezoidale*

**2.50:** Flat-belt pulley - *Cinghia piatta*

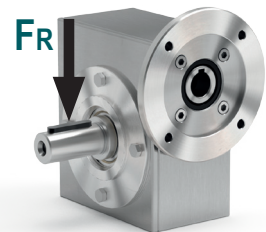

**If your application requires higher radial loads, contact our technical office. Higher loads may be possible.**

Nel caso la vostra applicazione richieda carichi radiali superiori consultare il nostro ufficio tecnico, valori maggiori possono essere accettati.



# How to select a gearbox

Come selezionare un riduttore

## A Select required torque (according to service factor)

Seleziona la coppia desiderata (comprensiva del fattore di servizio)

## B Select output speed

Seleziona la velocità in uscita

## C Select gear ratio in the line corresponding to the chosen motor power

Sulla riga corrispondente alla motorizzazione prescelta si può rilevare il rapporto di riduzione

## D Select motor flange available (if requested)

Scegli la flangia disponibile (se richiesta)

Gear size  
Grandezza  
riduttore

C

Ratio  
Rapporto

Transmitted torque  
Momento torcente  
trasmesso

Nominal power  
Potenza nominale

Flange code  
Codice flangia

Dynamic efficiency  
Rendimento dinamico

Input speed  
Velocità in entrata

LD45

41  
Nm

VFL series

Stainless steel shielded worm gearboxes

Riduttori a vite senza fine schermati in acciaio inox

Input speed ( $n_1$ ) = 1400 min<sup>-1</sup>

Output speed $n_2$ [min <sup>-1</sup> ]	Ratio $i$	Motor power $P_{1M}$ [kW]	Output torque $M_{2M}$ [Nm]	Service factor f.s.	Nominal power $P_{1R}$ [kW]	Nominal torque $M_{2R}$ [Nm]	B5 motor flanges		B14 motor flanges		Dynamic efficiency RD	Tooth module [mm]	Ratio code 
							-	-	-P 63	-Q 71			
200	7	0.37	14	2.2	0.80	30			C		80	2.2	01
140	10	0.37	20	1.5	0.57	30			C		79	2.2	02
100	14	0.37	27	1.1	0.41	30			C		77	2.4	03
67	21	0.37	36	1.2	0.43	41			C		67	1.6	04
50	28	0.25	31	1.3	0.33	41			C		65	2.5	05
38	37	0.25	40	1.0	0.26	41			C		63	1.8	06
30	46	0.25	46	0.9	0.22	41			C		59	1.5	07
23	60	0.18	41	1.0	0.18	41			C		56	1.2	08
20	70	0.12	31	1.0	0.12	30			C		54	1.0	09
13.7	102	0.12	41	0.7	0.09	29			C		49	0.72	10

B Output speed  
Velocità in uscita

Motor power  
Potenza motore

Service factor  
Fattore di servizio

A Nominal torque  
Momento torcente  
nominale

Nominal module  
Modulo nominale

Notes  
Note

### Type of load and starts per hour

Tipo di carico e avviamenti per ora

### Oper. hours per day

Ore di funz. giorn.

		Oper. hours per day		
		<2h	2÷8h	8÷16h
Continuous or intermittent application with start / hour <i>Applicazione continua o intermittente con numero operazioni/ora</i>	Uniform - <i>Uniforme</i>	0.9	1	1.25
	Moderate - <i>Moderato</i>	1	1.25	1.5
	Heavy - <i>Forte</i>	1.25	1.5	1.75
Intermittent application with start / hour <i>Applicazione intermittente con numero operazioni/ora</i>	Uniform - <i>Uniforme</i>	1.25	1.5	1.75
	Moderate - <i>Moderato</i>	1.5	1.75	2
	Heavy - <i>Forte</i>	1.75	2	2.25

D Motor flange available  
Flange disponibili

B) Mounting with reduction bushing  
Montaggio con boccola di riduzione 

C) Motor flange holes position/terminal box position  
Posizione fori flangia/basetta motore 

B) Available without reduction bushing  
Disponibile anche senza boccola

# VFL series Stainless steel shielded worm gearboxes

Riduttori a vite senza fine schermati in acciaio inox

Input speed ( $n_1$ ) = 1400 min<sup>-1</sup>

Output speed $n_2$ [min <sup>-1</sup> ]	Ratio $i$	Motor power $P_{1M}$ [kW]	Output torque $M_{2M}$ [Nm]	Service factor f.s	Nominal power $P_{1R}$ [kW]	Nominal torque $M_{2R}$ [Nm]	B5 motor flanges		B14 motor flanges		Dynamic efficiency RD	Tooth module [mm]	Ratio code
							-	-	-P 63	-Q 71			
200	7	0.37	14	2.2	0.80	30			C		80	2.2	01
140	10	0.37	20	1.5	0.57	30			C		79	2.2	02
100	14	0.37	27	1.1	0.41	30			C		77	2.4	03
67	21	0.37	36	1.2	0.43	41			C		67	1.6	04
50	28	0.25	31	1.3	0.33	41			C		65	2.5	05
38	37	0.25	40	1.0	0.26	41			C		63	1.8	06
30	46	0.25	46	0.9	0.22	41			C		59	1.5	07
23	60	0.18	41	1.0	0.18	41			C		56	1.2	08
20	70	0.12	31	1.0	0.12	30			C		54	1.0	09
13.7	102	0.12	41	0.7	0.09	29			C		49	0.72	10

Motor flanges available  
Flange motore disponibili



B) Supplied with reduction bushing  
Fornito con bussola di riduzione

B) Available on request without reduction bushing  
Disponibile a richiesta senza bussola di riduzione



C) Motor flange holes position  
Posizione fori flangia motore

## Lubrication

Lubrificazione

Unit LD45 is supplied with synthetic oil to assure long life lubrication.

Food grade oil is available on request.

See Table 1 for lubrication and recommended quantity.

See Table 2 for possible radial and axial loads on the gearbox.

Il riduttore tipo LD45 viene fornito con olio sintetico e lubrificazione tipo "long life".

Disponibile a richiesta olio alimentare.

Vedi Tabella 1 per oli e quantità consigliati.

Vedi Tabella 2 per i carichi radiali e assiali applicabili al riduttore.

Oil quantity for  
all positions:  
0.08Lt.

Quantità olio per tutte  
le posizioni: 0.08Lt.

**Agip**  
Telium VSF 320

**Shell**  
Omala S4 WE 320

## Radial and axial loads

Carichi radiali e assiali

### Output shaft

Albero di uscita

$n_2$ [min <sup>-1</sup> ]	$F_A$ [N]	$F_R$ [N]
200	180	900
150	200	1000
100	220	1100
75	240	1200
50	260	1400
25	300	1800
15	400	2000

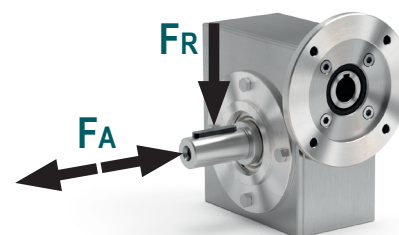

41  
Nm

LD45

PLD45UN..

**Basic gearbox**  
*Riduttore base*

**Gearbox weight**  
*Peso riduttore* **4.50 kg**

M. flanges	Kit code	øF	A
63B14	KI504047	90	74.5
71B14	KI504045	105	72

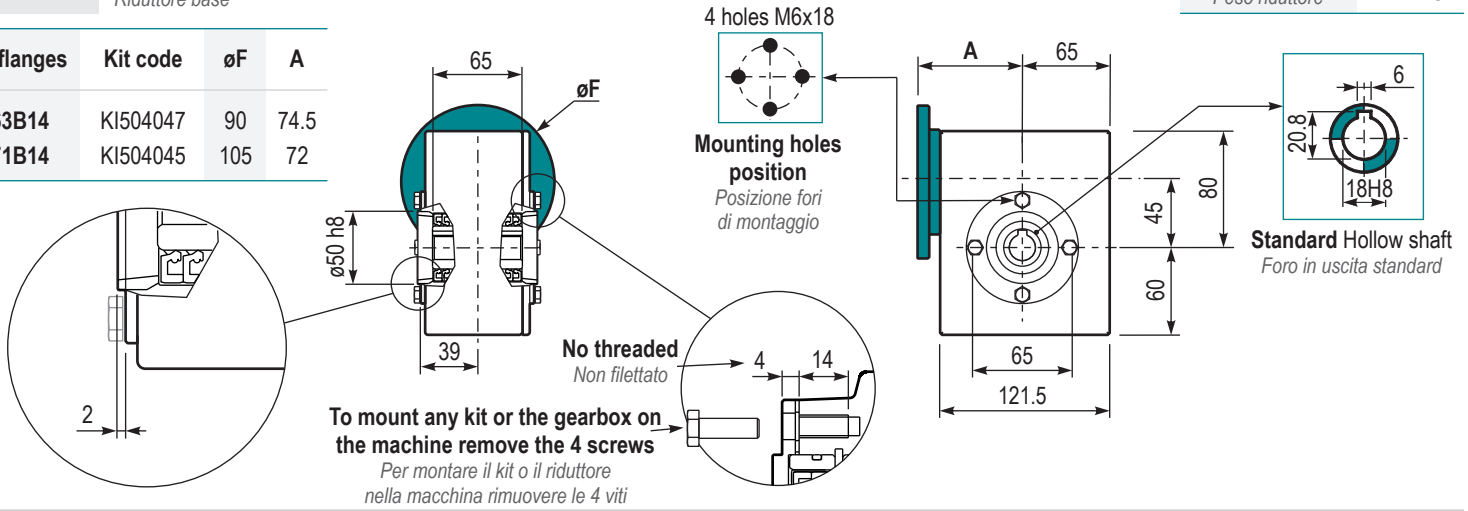

PLD45PA..

**Feet**  
*Piedini*

PLD45PV..

**Feet**  
*Piedini*

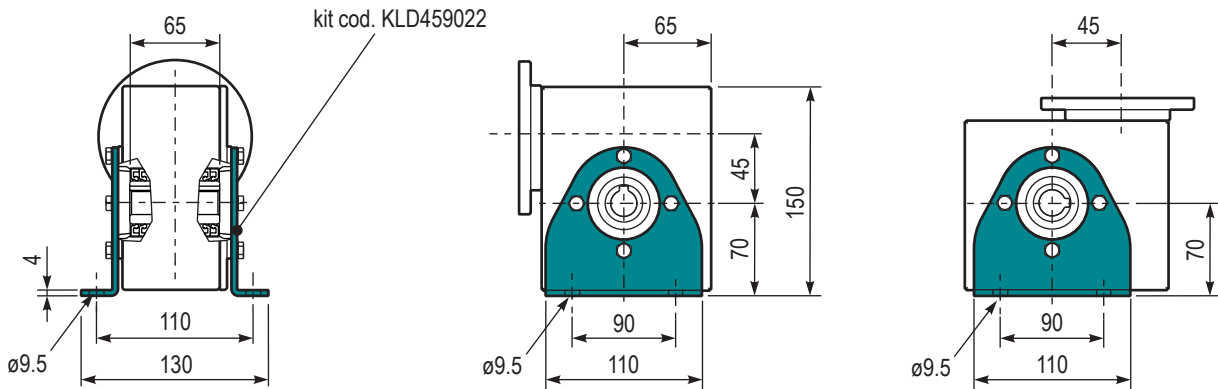

PLD45..S..

**Single output shaft**  
*Albero semplice in uscita*

PLD45BR..

**Reaction arm**  
*Braccio di reazione*

cod. LD450209

**Protection cap ( on request )**  
*A richiesta coperchio di protezione*

kit cod. KI0455028

kit cod. KLD459027

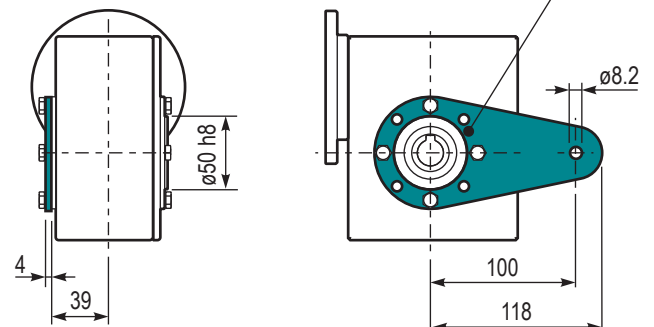
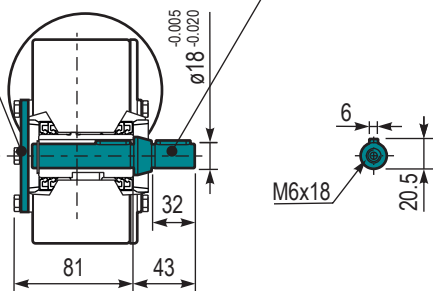

Input speed ( $n_1$ ) = 1400 min<sup>-1</sup>

Output speed $n_2$ [min <sup>-1</sup> ]	Ratio $i$	Motor power $P_{1M}$ [kW]	Output torque $M_{2M}$ [Nm]	Service factor $f_s$	Nominal power $P_{1R}$ [kW]	Nominal torque $M_{2R}$ [Nm]	B5 motor flanges			B14 motor flanges			Dynamic efficiency RD	Tooth module [mm]	Ratios code
							-	-	-	-P 63	-Q 71	-R 80			
200	7	0.75	29	1.9	1.5	57				C			82	2.5	01
140	10	0.75	41	1.5	1.1	62				C			80	2.4	02
100	14	0.75	57	1.2	0.90	68				C			79	2.6	03
78	18	0.55	51	1.2	0.67	62				C			75	2.0	04
54	26	0.55	67	1.0	0.54	66				C			69	2.7	05
47	30	0.55	79	0.9	0.50	72				C			70	2.5	12
39	36	0.37	63	1.2	0.43	72				C			69	2.1	06
33	43	0.37	72	1.0	0.35	68				C			66	1.8	07
28	50	0.25	53	1.2	0.31	66				C			62	1.5	13
23	60	0.25	59	1.0	0.26	62				C			58	1.3	08
21	68	0.25	66	0.9	0.22	58				C			57	1.2	09
17.5	80	0.18	53	1.1	0.19	57				C			54	1.0	10
14	100	0.12	41	1.3	0.15	51				C			50	0.8	11

Motor flanges available  
Flange motore disponibili



B) Supplied with reduction bushing  
Fornito con bussola di riduzione



B) Available on request without reduction bushing  
Disponibile a richiesta senza bussola di riduzione



C) Motor flange holes position  
Posizione fori flangia motore

## Lubrication

Lubrificazione

Unit LD50 is supplied with synthetic oil to assure long life lubrication.  
Food grade oil is available on request.

See Table 1 for lubrication and recommended quantity.

See Table 2 for possible radial and axial loads on the gearbox.

Il riduttore tipo LD50 viene fornito con olio sintetico e lubrificazione tipo "long life".  
Disponibile a richiesta olio alimentare.

Vedi Tabella 1 per oli e quantità consigliati.

Vedi Tabella 2 per i carichi radiali e assiali applicabili al riduttore.

Oil quantity for  
all positions:  
0.12Lt.

Quantità olio per tutte  
le posizioni: 0.12Lt.

**Agip**  
Telium VSF 320

**Shell**  
Omala S4 WE 320

## Radial and axial loads

Carichi radiali e assiali

### Output shaft

Albero di uscita

$n_2$ [min <sup>-1</sup> ]	$F_A$ [N]	$F_R$ [N]
200	240	1200
150	280	1400
100	300	1500
75	340	1700
50	380	1900
25	480	2500
15	560	2800

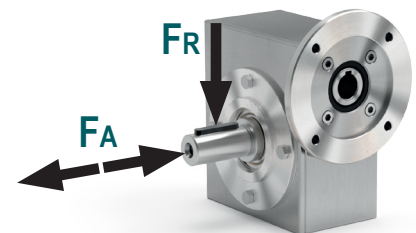

72  
Nm

LD50

PLD50**UN**.. **Basic gearbox**  
*Riduttore base*

**Gearbox weight**  
*Peso riduttore* **6.80 kg**

M. flanges	Kit code	øF	A
63B14	KI504047	90	79
71B14	KI504045	105	76.5
80B14	KI504046	120	77

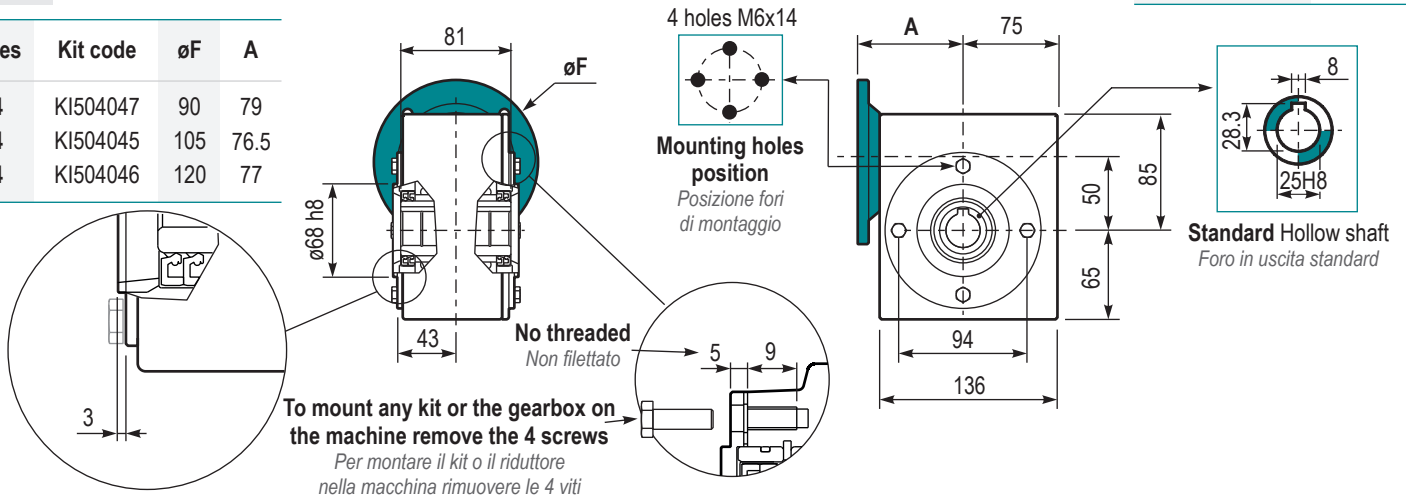

PLD50**PA**.. **Feet**  
*Piedini*

PLD50**PV**.. **Feet**  
*Piedini*

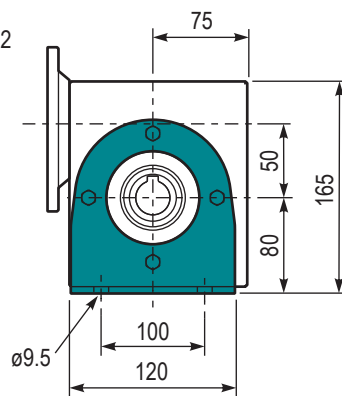
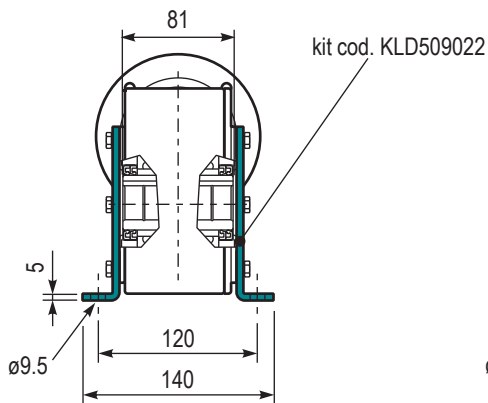

PLD50..**S**.. **Single output shaft**  
*Albero semplice in uscita*

PLD50..**BR**.. **Reaction arm**  
*Braccio di reazione*

cod. LD500209  
**Protection cap ( on request )**  
*A richiesta coperchio di protezione* kit cod. KI0505028

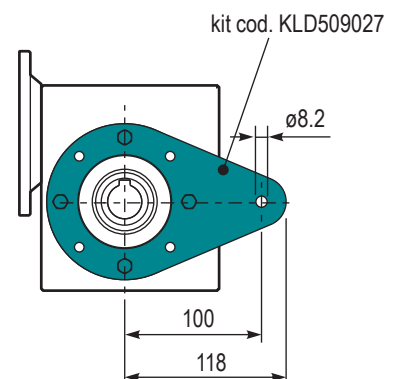
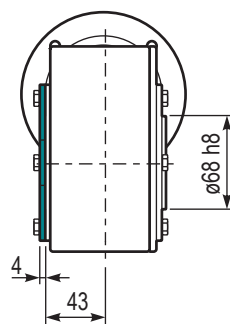
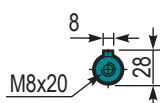
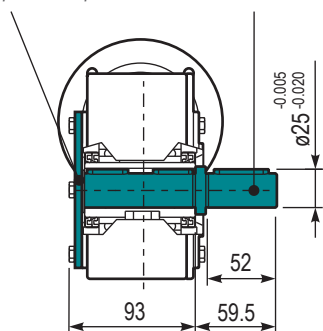

Input speed ( $n_1$ ) = 1400 min<sup>-1</sup>

Output speed $n_2$ [min <sup>-1</sup> ]	Ratio $i$	Motor power $P_{1M}$ [kW]	Output torque $M_{2M}$ [Nm]	Service factor $f_s$	Nominal power $P_{1R}$ [kW]	Nominal torque $M_{2R}$ [Nm]	B5 motor flanges				B14 motor flanges			Dynamic efficiency RD	Tooth module [mm]	Ratio code
							-	-	-	-	-Q	-R	-T			
200	7	1.8	71	1.8	3.2	125	-	-	-	-	C	C		83	3.1	01
140	10	1.8	99	1.4	2.4	134	-	-	-	-	C	C		81	3.1	02
93	15	1.5	121	1.1	1.7	138	-	-	-	-	C	C		79	3.1	03
74	19	1.1	111	1.2	1.4	138	-	-	-	-	C	C		78	2.6	04
58	24	1.1	135	1.0	1.2	142	-	-	-	-	C	C		75	2.0	05
47	30	1.1	167	0.9	0.96	146	-	-	-	-	C	C		74	3.2	06
39	36	0.75	125	1.2	0.88	147	-	-	-	-	C	C		68	2.7	07
35	40	0.75	135	1.0	0.78	140	-	-	-	-	C	C		66	2.5	13
31	45	0.55	111	1.2	0.67	135	-	-	-	-	C	C		66	2.1	08
23	60	0.55	140	0.9	0.51	130	-	-	-	-	C	C		62	1.6	12
21	67	0.55	151	0.8	0.45	124	-	-	-	-	C	C		60	1.5	09
17.5	80	0.37	115	1.0	0.38	119	-	-	-	-	C	C		57	1.3	10
14.9	94	0.37	123	1.0	0.36	119	-	-	-	-	C	C		52	1.1	11

Motor flanges available  
Flange motore disponibili



B) Supplied with reduction bushing  
Fornito con bussola di riduzione



B) Available on request without reduction bushing  
Disponibile a richiesta senza bussola di riduzione



C) Motor flange holes position  
Posizione fori flangia motore

## Lubrication

Lubrificazione

Unit LD63 is supplied with synthetic oil to assure long life lubrication.  
Food grade oil is available on request.

See Table 1 for lubrication and recommended quantity.

See Table 2 for possible radial and axial loads on the gearbox.

Il riduttore tipo LD63 viene fornito con olio sintetico e lubrificazione tipo "long life".

Disponibile a richiesta olio alimentare.

Vedi Tabella 1 per oli e quantità consigliati.

Vedi Tabella 2 per i carichi radiali e assiali applicabili al riduttore.

Oil quantity for  
all positions:  
0.30Lt.

Quantità olio per tutte  
le posizioni: 0.30Lt.

**Agip**  
Telium VSF 320

**Shell**  
Omala S4 WE 320

## Radial and axial loads

Carichi radiali e assiali

### Output shaft

Albero di uscita

$n_2$ [min <sup>-1</sup> ]	$F_A$ [N]	$F_R$ [N]
200	360	1800
150	400	2000
100	460	2300
75	500	2500
50	600	3000
25	700	3800
15	800	4000

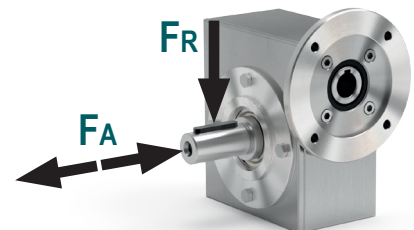

147 Nm

LD63

PLD63UN.. **Basic gearbox**  
Riduttore base

M. flanges	Kit code	øF	A
71B14	KI634047	105	98
80B14	KI634046	120	100
90B14	KI634041	140	100

**Gearbox weight** 12.70 kg  
Peso riduttore

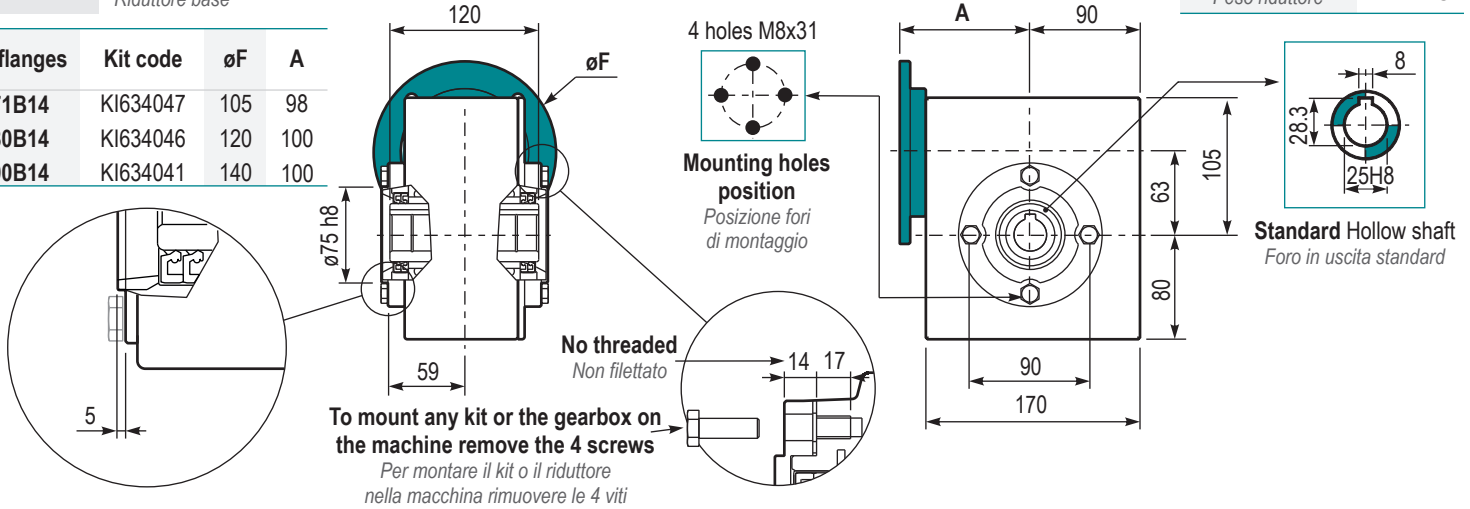

PLD63PA.. **Feet**  
Piedini

PLD63PV.. **Feet**  
Piedini

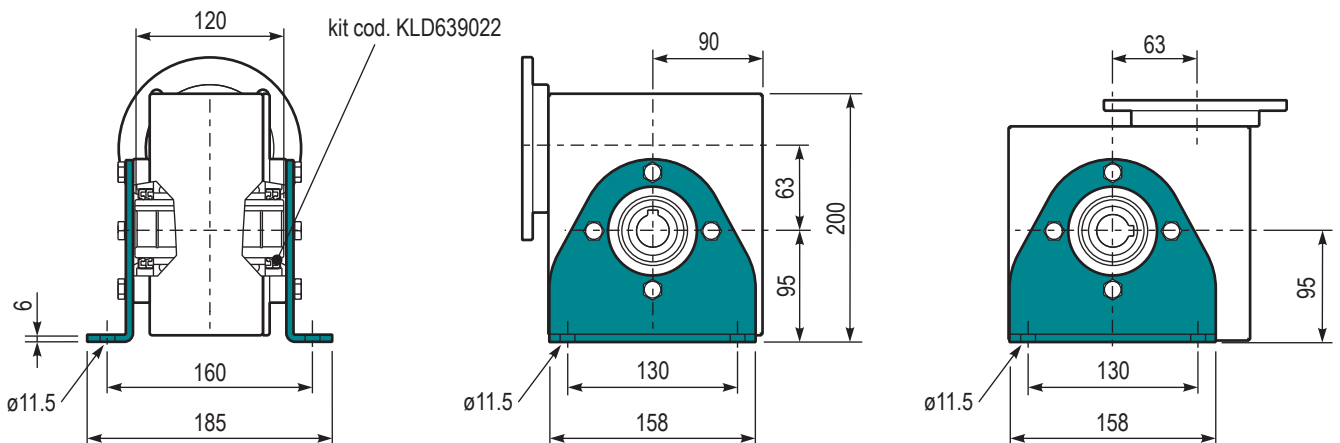

PLD63..S.. **Single output shaft**  
Albero semplice in uscita

PLD63BR.. **Reaction arm**  
Braccio di reazione

cod. LD630209  
**Protection cap ( on request )**  
A richiesta coperchio di protezione

kit cod. KLD639027

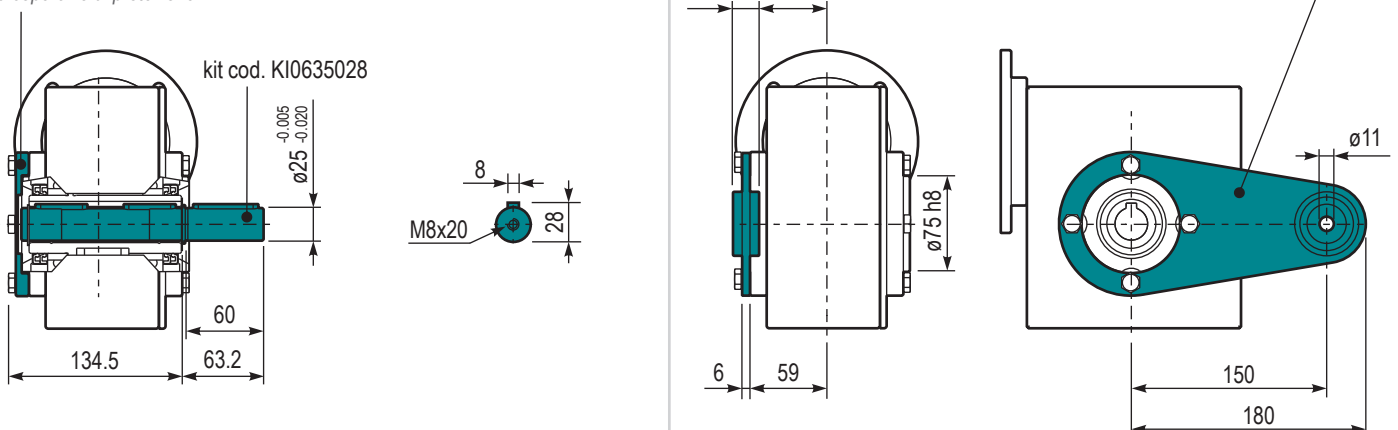

Input speed ( $n_1$ ) = 1400 min<sup>-1</sup>

Output speed $n_2$ [min <sup>-1</sup> ]	Ratio $i$	Motor power $P_{1M}$ [kW]	Output torque $M_{2M}$ [Nm]	Service factor $f_s$	Nominal power $P_{1R}$ [kW]	Nominal torque $M_{2R}$ [Nm]	B5 motor flanges				B14 motor flanges			Dynamic efficiency RD	Tooth module [mm]	Ratios code 
							-	-	-	-	-R	-T	-U			
200	7	4.0	168	1.5	6.1	257								88	4.23	01
140	10	4.0	218	1.3	5.2	284								80	4.2	02
100	14	3.0	223	1.4	4.1	305								78	4.5	03
70	20	2.2	237	1.2	2.7	294								79	3.4	04
64	22	2.2	258	1.1	2.5	294								78	3.1	05
50	28	2.2	315	1.1	2.4	347								75	4.7	06
37	38	1.5	276	1.2	1.8	336								71	3.5	07
30	46	1.5	320	1.0	1.5	326								68	3.1	08
27	52	1.1	258	1.1	1.2	289								66	2.7	09
21	67	1.1	327	0.9	0.97	289								65	2.1	10
18.9	74	0.75	220	1.2	0.91	268								58	1.9	11
14.6	96	0.55	191	1.3	0.70	242								53	1.5	12

**Motor flanges available**  
Flange motore disponibili



**B) Supplied with reduction bushing**  
Fornito con bussola di riduzione



**B) Available on request without reduction bushing**  
Disponibile a richiesta senza bussola di riduzione



**C) Motor flange holes position**  
Posizione fori flangia motore

## Lubrication

Lubrificazione

Unit LD85 is supplied with synthetic oil to assure long life lubrication.  
Food grade oil is available on request.

See Table 1 for lubrication and recommended quantity.

See Table 2 for possible radial and axial loads on the gearbox.

*Il riduttore tipo LD85 viene fornito con olio sintetico e lubrificazione tipo "long life".*

*Disponibile a richiesta olio alimentare.*

*Vedi Tabella 1 per oli e quantità consigliati.*

*Vedi Tabella 2 per i carichi radiali e assiali applicabili al riduttore.*

**Oil quantity for  
all positions:  
0.95Lt.**

*Quantità olio per tutte  
le posizioni: 0.95Lt.*

**Agip**  
*Telium VSF 320*

**Shell**  
*Omala S4 WE 320*

## Radial and axial loads

Carichi radiali e assiali

### Output shaft

Albero di uscita

$n_2$ [min <sup>-1</sup> ]	$F_A$ [N]	$F_R$ [N]
200	500	2500
150	580	2900
100	600	3000
75	700	3500
50	800	4000
25	1000	5000
15	1160	5800

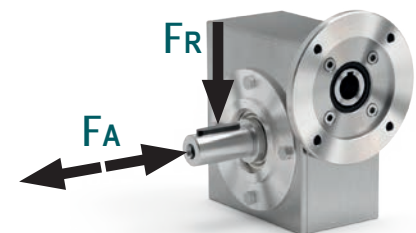



347 Nm

LD85

PLD85 **UN**.. Basic gearbox  
Riduttore base

M. flanges	Kit code	øF	A
80B14	KI854046	120	119
90B14	KI854045	140	119
100/112B14	KI854041	160	128

Gearbox weight  
Peso riduttore 21.00 kg

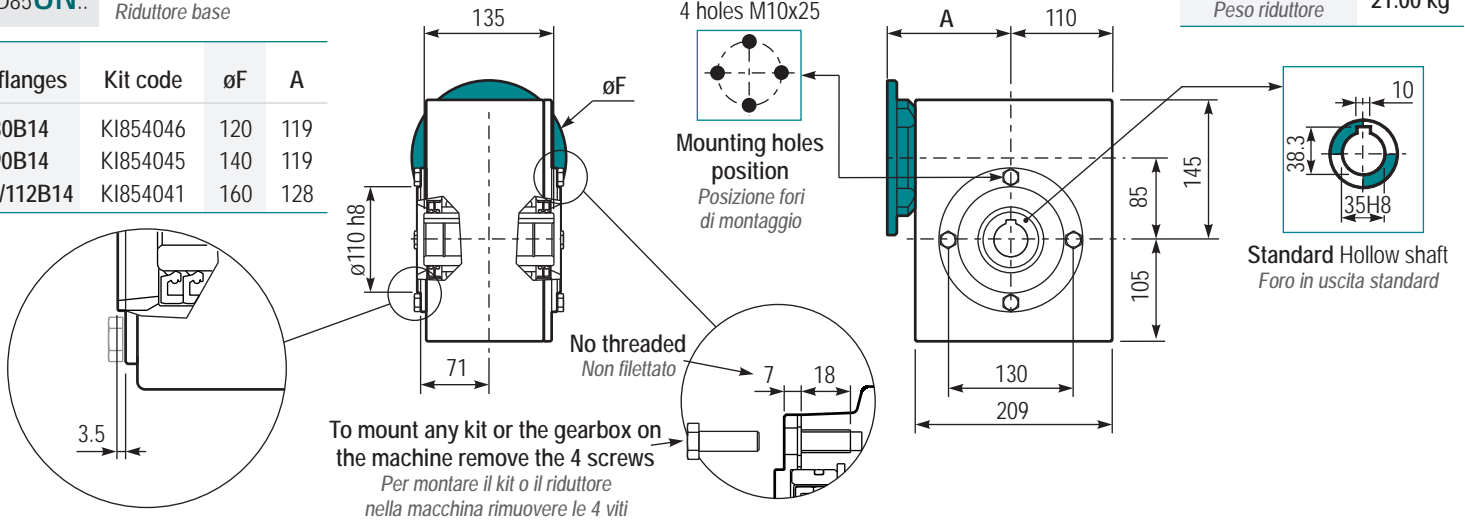

PLD85 **PA**.. Feet  
Piedini

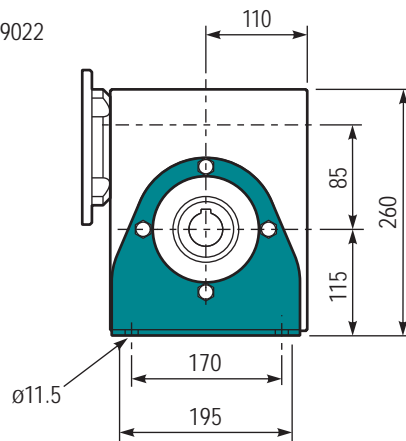
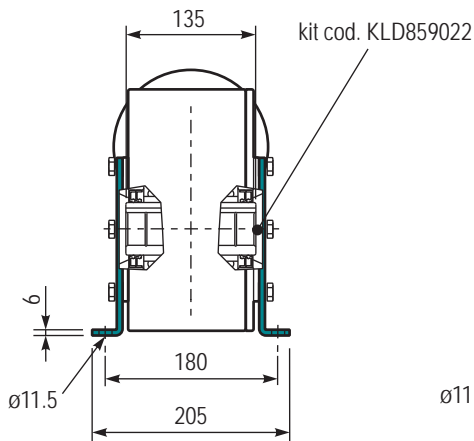

PLD85 **PV**.. Feet  
Piedini

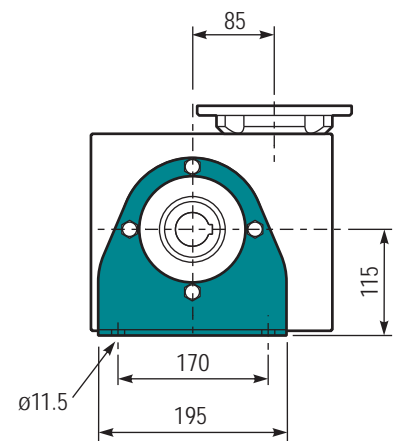

PLD85 **S**.. Single output shaft  
Albero semplice in uscita

cod. LD850209  
Protection cap (on request)  
A richiesta coperchio di protezione

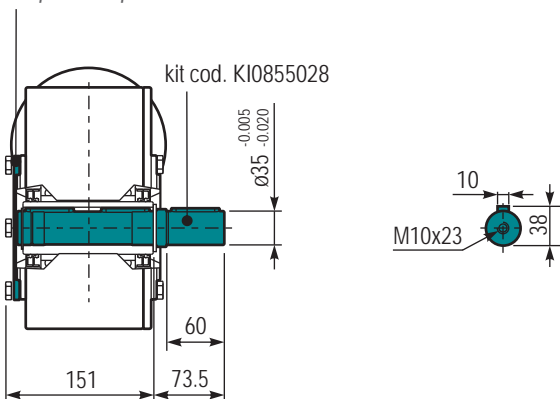

PLD85 **BR**.. Reaction arm  
Braccio di reazione

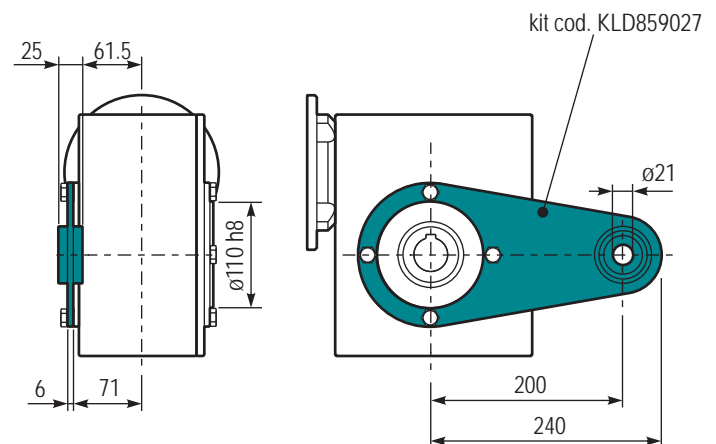



# L RCL series Stainless steel shielded ratio multipliers

*Riduttori ad uno stadio schermati in acciaio inox*

Section **4**  
Sezione 4

This range is   certified

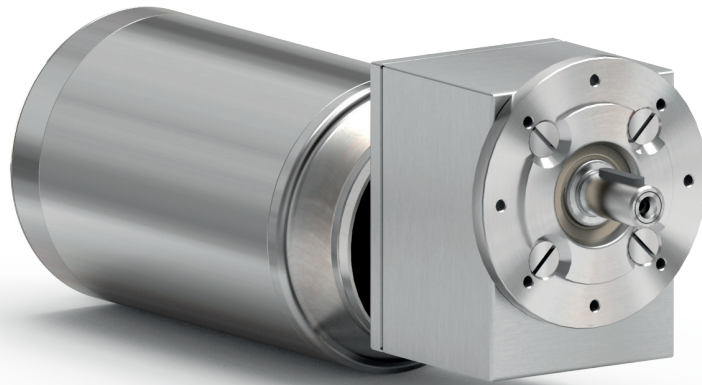

# FEATURES

Caratteristiche

## RCL series Stainless steel shielded ratio multipliers

Riduttori ad uno stadio schermati in acciaio inox

Type <i>Tipo</i>	Torque <i>Coppia</i>	Center distance <i>Interasse</i>	Input power <i>Potenza in entrata</i>	Hollow output shaft <i>Albero cavo in uscita</i>
411L	38 Nm	38 mm	0.37 ÷ 1.5 kW	ø19 mm
511L	110 Nm	50 mm	1.1 ÷ 4.0 kW	ø28 mm

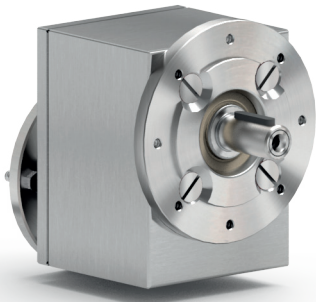

This product is:

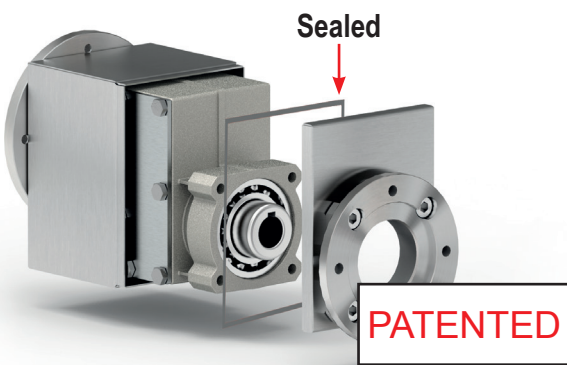

The "L" series is an already totally enclosed aluminum gearboxes, that is shielded and sealed by stainless steel 316L case.

*La serie "L" è ottenuta da un riduttore in alluminio che viene incapsulato all'interno di un carter sigillato in acciaio inox 316L.*

**Output shaft is produced in AISI 316L.**

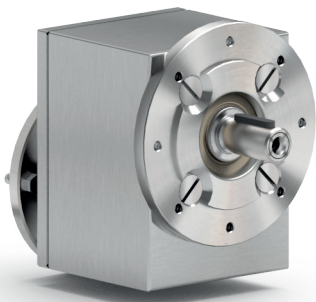

*Albero in uscita in AISI 316L.*



**Fully modular IEC flanges and compact NEMA C motor flanges.**

*Flange IEC e NEMA completamente modulari.*

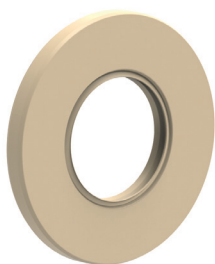

**Standard FPM (FKM) seals are used, since seals will be in a closed area.**

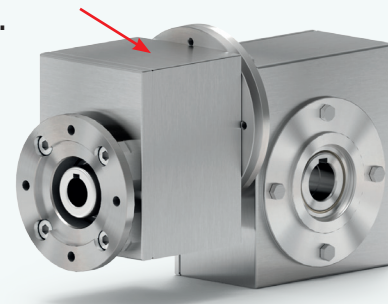

*Anelli di tenuta FPM(FKM) standard.*





**Hardened and ground gears.**

*Ingranaggi temprati e rettificati.*

# How to order

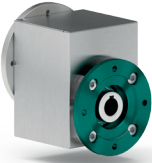
Codifica

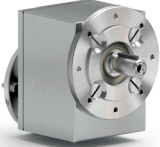
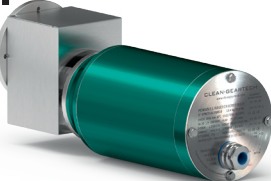
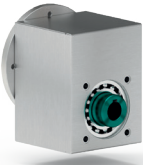
<b>P</b>	<b>411L</b>	<b>-F</b>	<b>1.57</b>	<b>C</b>
Type <i>Tipo</i>	Size <i>Grandezza</i>	Mounting <i>Montaggio</i>	Ratio <i>Rapporto</i>	Output shaft <i>Albero lento</i>
<b>P</b> 	<b>411L</b> <b>511L</b>	<b>-F</b> 	See technical data table <i>Vedi tabelle dati tecnici</i>	
<b>M</b> 		<b>411L</b> <b>C</b> -> $\varnothing 19$		
<b>B</b> 		<b>511L</b> <b>G</b> -> $\varnothing 28$		

**1****-T****B3****-**

**With Type M specify terminal box position**  
 Con tipo M specificare posizione morsetteria

**Output flange**  
 Flangia uscita

**Motor size**  
 Grandezza motore

**Mounting position**  
 Posizione di montaggio

**Input bore**  
 Foro entrata

**Terminal box position**  
 Posizione morsetteria

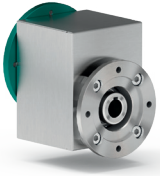

**Flange**  
 Flange

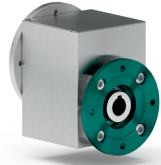
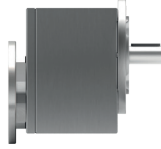
**B3**

**Standard bore**  
 Foro standard

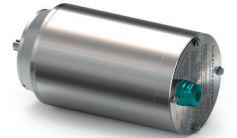
**A**

411L

**1** -> ø120

511L

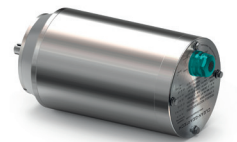
**3** -> ø160**IEC B14****-Q** -> 71 B14 (ø105)**-R** -> 80 B14 (ø120)**-T** -> 90 B14 (ø140)**-U** -> 100-122 B14 (ø160)**B6****B**

**Without flange**  
 Senza flangia

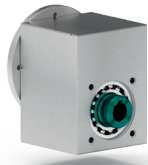
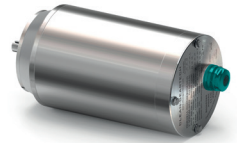
**B7****C**

411L

**-1** -> ø14 (71 B5)**-2** -> ø19 (80 B5)**-3** -> ø24 (90 B5)

511L

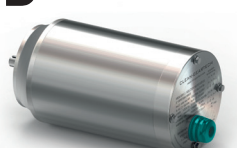
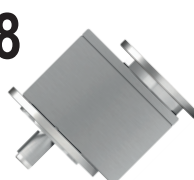
**-2** -> ø19 (80 B5)**-3** -> ø24 (90 B5)**-4** -> ø28 (100 B5)**B8****D****V5****V6****V8**

# Useful formulas

Formule utili

## Required power - Potenza richiesta

Lifting - Sollevamento

Rotation - Rotazione

Linear movement - Traslazione

$$P_{[kW]} = \frac{M_{[Kg]} \cdot g_{[9.81]} \cdot v_{[m/s]}}{1000}$$

$$P_{[kW]} = \frac{M_{[Nm]} \cdot n_{[rpm]}}{9550}$$

$$P_{[kW]} = \frac{F_{[N]} \cdot v_{[m/s]}}{1000}$$

## Torque - Coppia

$$M_{[Nm]} = \frac{9550 \cdot P_{[kW]}}{n_{[rpm]}}$$

$$M_{[lb\ in]} = \frac{63030 \cdot P_{[HP]}}{n_{[rpm]}}$$

## Radial loads - Carichi radiali

Radial load generated by external transmissions keyed onto input and/or output shafts.

Forza radiale generata da organi di trasmissione calettati sugli alberi di ingresso e/o uscita.

$$F_R_{[N]} = \frac{M_{[Nm]} \cdot 2000}{d_{[mm]}} \cdot f_k$$

$$F_R_{[N]} = \frac{M_{[lb\ in]} \cdot 8.9}{d_{[in]}} \cdot f_k$$

**M:** Output torque - *Momento torcente*

**d:** Diam. of driving element - *Diametro primitivo*

**f<sub>k</sub>:** Factor - *Coefficiente di trasformazione*

1.15: Gearwheels - *Ingranaggi*

1.25: Chain sprockets - *Catena*

1.75: Narrow v-belt pulley - *Cinghia Trapezoidale*

2.50: Flat-belt pulley - *Cinghia piatta*



If your application requires higher radial loads, contact our technical office. Higher loads may be possible.

Nel caso la vostra applicazione richieda carichi radiali superiori consultare il nostro ufficio tecnico, valori maggiori possono essere accettati.



# How to select a gearbox

Come selezionare un riduttore

## A Select required torque (according to service factor)

Seleziona la coppia desiderata (comprensiva del fattore di servizio)

## B Select output speed

Seleziona la velocità in uscita

## C Select gear ratio in the line corresponding to the chosen motor power

Sulla riga corrispondente alla motorizzazione prescelta si può rilevare il rapporto di riduzione

## D Select motor flange available (if requested)

Scegli la flangia disponibile (se richiesta)

Gear size  
Grandezza  
riduttore

C

Ratio  
Rapporto

Transmitted torque  
Momento torcente  
trasmesso

Nominal power  
Potenza nominale

Flange code  
Codice flangia

Input speed  
Velocità in entrata

411L

38  
Nm



RCL series

Stainless steel shielded ratio multipliers

Riduttori ad uno stadio schermati in acciaio inox

The dynamic efficiency is **0.98** for all ratios

Input speed ( $n_1$ ) = 1400 min<sup>-1</sup>

Output speed $n_2$ [min <sup>-1</sup> ]	Ratio $i$	Motor power $P_{1M}$ [kW]	Output torque $M_{2M}$ [Nm]	Service factor $f.s$	Nominal power $P_{1R}$ [kW]	Nominal torque $M_{2R}$ [Nm]	B5 motor flanges			B14 motor flanges			Output shaft  standard ø19	Ratios code 
							-	-	-	-Q 71	-R 80	-T 90		
891	<b>1.57</b>	1.5	16	1.3	<b>1.9</b>	<b>20</b>			C	C		2844	01	
493	<b>2.84</b>	1.5	28	1.2	<b>1.8</b>	<b>35</b>			C	C		1954	02	
425	<b>3.29</b>	1.5	33	1.2	<b>1.7</b>	<b>38</b>			C	C		1756	03	
362	<b>3.87</b>	1.5	39	1.0	<b>1.5</b>	<b>40</b>			C	C		1558	04	
303	<b>4.62</b>	1.5	46	1.0	<b>1.5</b>	<b>47</b>			C	C		1360	05	
222	<b>6.30</b>	1.1	46	1.0	<b>1.1</b>	<b>46</b>			C	C		1063	06	
170	<b>8.22</b>	0.55	30	1.3	<b>0.69</b>	<b>38</b>			C	C		974	07	
129	<b>10.86</b>	0.37	27	1.0	<b>0.39</b>	<b>28</b>			C	C		776	08	

B Output speed  
Velocità in uscita

Motor power  
Potenza motore

Service factor  
Fattore di servizio

A Nominal torque  
Momento torcente  
nominale

Output shaft diam.  
Diametro albero uscita

Notes  
Note

### Type of load and starts per hour

Tipo di carico e avviamenti per ora

Oper. hours per day  
Ore di funz. giorn.

		Oper. hours per day		
		3h	10h	24h
Continuous or intermittent application with start / hour <i>Applicazione continua o intermittente con numero operazioni/ora</i>	Uniform - <i>Uniforme</i>	0.8	1	1.25
	Moderate - <i>Moderato</i>	1	1.25	1.5
	Heavy - <i>Forte</i>	1.25	1.5	1.75
Intermittent application with start / hour <i>Applicazione intermittente con numero operazioni/ora</i>	Uniform - <i>Uniforme</i>	1	1.25	1.5
	Moderate - <i>Moderato</i>	1.25	1.5	1.75
	Heavy - <i>Forte</i>	1.5	1.75	2.15

D Motor flange available  
Flange disponibili

B) Mounting with reduction bushing  
*Montaggio con boccia di riduzione*

C) Motor flange holes position/terminal box position  
*Posizione fori flangia/basetta motore*

B) Available without reduction bushing  
*Disponibile anche senza boccia*

# 411L



## 38 Nm

# RCL series Stainless steel shielded ratio multipliers

Riduttori ad uno stadio schermati in acciaio inox

The dynamic efficiency is **0.98** for all ratios

Input speed ( $n_1$ ) = 1400 min<sup>-1</sup>

Output speed $n_2$ [min <sup>-1</sup> ]	Ratio $i$	Motor power $P_{1M}$ [kW]	Output torque $M_{2M}$ [Nm]	Service factor $f_s$	Nominal power $P_{1R}$ [kW]	Nominal torque $M_{2R}$ [Nm]	B5 motor flanges			B14 motor flanges			Output shaft 	Ratios code 
							-	-	-	-Q	-R	-T		
891	1.57	1.5	16	1.3	1.9	20	-	-	-	71	80	90	2844	01
493	2.84	1.5	28	1.2	1.8	35				C	C		1954	02
425	3.29	1.5	33	1.2	1.7	38				C	C		1756	03
362	3.87	1.5	39	1.0	1.5	40				C	C		1558	04
303	4.62	1.5	46	1.0	1.5	47				C	C	standard	1360	05
222	6.30	1.1	46	1.0	1.1	46				C	C	$\varnothing 19$	1063	06
170	8.22	0.55	30	1.3	0.69	38				C	C		974	07
129	10.86	0.37	27	1.0	0.39	28				C	C		776	08

**Motor flanges available**  
Flange motore disponibili

 **B) Supplied with reduction bushing**  
Fornito con bussola di riduzione

**B) Available on request without reduction bushing**  
Disponibile a richiesta senza bussola di riduzione

 **C) Motor flange holes position**  
Posizione fori flangia motore

## Lubrication

Lubrificazione

Unit 411L is supplied with synthetic oil to assure long life lubrication. Food grade oil is available on request.

See Table 1 for lubrication and recommended quantity.

See Table 2 for possible radial and axial loads on the gearbox.

*Il riduttore tipo 411L viene fornito con olio sintetico e lubrificazione tipo "long life".*

*Disponibile a richiesta olio alimentare.*

*Vedi Tabella 1 per oli e quantità consigliati.*

*Vedi Tabella 2 per i carichi radiali e assiali applicabili al riduttore.*

**Oil quantity for all positions: 0.10Lt.**

Quantità olio per tutte le posizioni: 0.10Lt

**Agip**  
Telium VSF 320

**Shell**  
Omala S4 WE 320

## Radial and axial loads

Carichi radiali e assiali

### Output shaft

Albero di uscita

$n_2$ [min <sup>-1</sup> ]	$F_A$ [N]	$F_R$ [N]
700	182	910
600	200	1000
400	230	1150
300	250	1250
200	290	1450
140	320	1600

$$F_{eq} = F_R \cdot \frac{41}{X + 21}$$

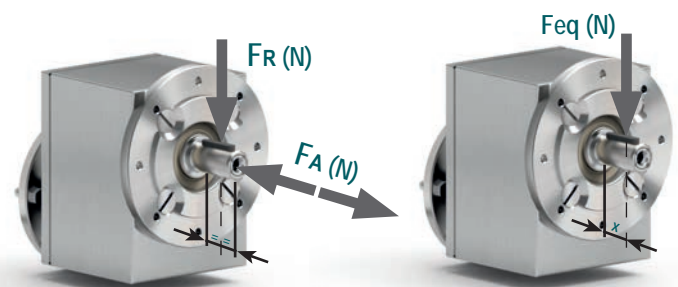

Tab. 1

Tab. 2

38  
Nm

411L

P411L-F... Basic gearbox  
Riduttore base

Gearbox weight 5.0 kg  
Peso riduttore

M. flanges	Kit code	øF	k1
71 B14	KI634047	105	120
80 B14	KI634046	120	122
90 B14	KI634041	140	122

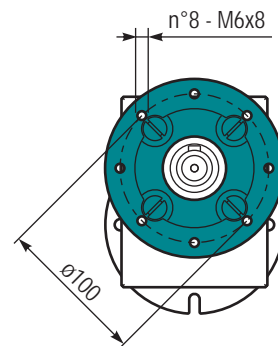
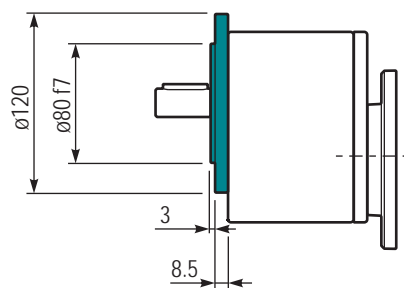
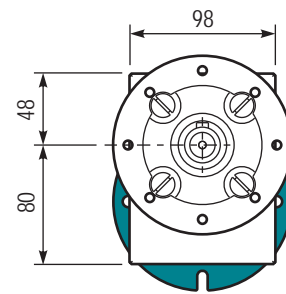
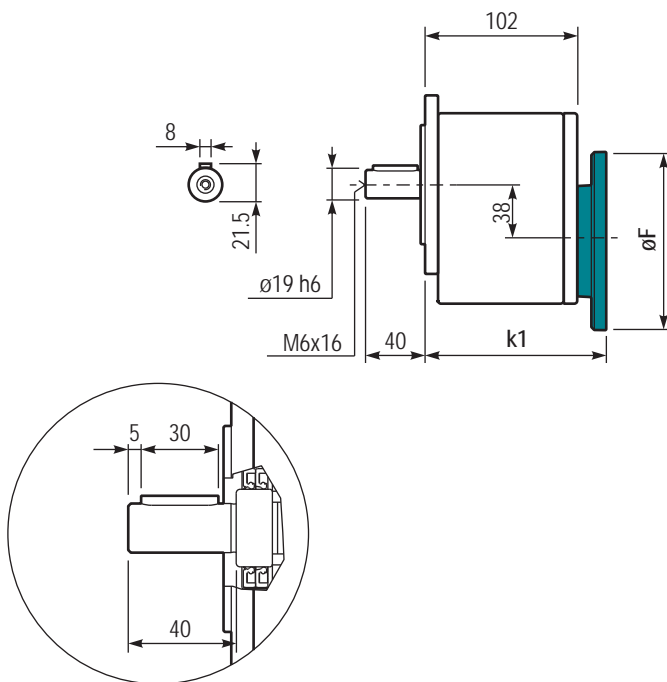

# 511L



## 110 Nm

# RCL series Stainless steel shielded ratio multipliers

Riduttori ad uno stadio schermati in acciaio inox

The dynamic efficiency is **0.98** for all ratios

Input speed ( $n_1$ ) = 1400 min<sup>-1</sup>

Output speed $n_2$ [min <sup>-1</sup> ]	Ratio $i$	Motor power $P_{1M}$ [kW]	Output torque $M_{2M}$ [Nm]	Service factor $f_s$	Nominal power $P_{1R}$ [kW]	Nominal torque $M_{2R}$ [Nm]	B5 motor flanges				B14 motor flanges			Output shaft 	Ratios code 
							-	-	-	-	-R	-T	-U		
1077	1.30	4	34	1.2	4.6	40								3039	01
571	2.45	4	64	1.1	4.3	70								2049	02
423	3.31	4	87	1.0	4.1	90								1653	03
325	4.31	4	113	1.0	3.8	110								1356	04
266	5.27	3	104	1.1	3.1	110								1158	05
184	7.63	2.2	111	1.0	2.2	110								861	06
133	10.50	1.1	77	1.0	1.1	80								663	07

**Motor flanges available**  
Flange motore disponibili

 **B) Supplied with reduction bushing**  
Fornito con bussola di riduzione

**B) Available on request without reduction bushing**  
Disponibile a richiesta senza bussola di riduzione

 **C) Motor flange holes position**  
Posizione fori flangia motore

## Lubrication

Lubrificazione

Unit 511L is supplied with synthetic oil to assure long life lubrication.  
Food grade oil is available on request.

See Table 1 for lubrication and recommended quantity.

See Table 2 for possible radial and axial loads on the gearbox.

Il riduttore tipo 511L viene fornito con olio sintetico e lubrificazione tipo "long life".

Disponibile a richiesta olio alimentare.

Vedi Tabella 1 per oli e quantità consigliati.

Vedi Tabella 2 per i carichi radiali e assiali applicabili al riduttore.

**Oil quantity for  
all positions:  
0.29Lt.**

Quantità olio per tutte  
le posizioni: 0.29Lt

**Agip**  
Telium VSF 320

**Shell**  
Omala S4 WE 320

## Radial and axial loads

Carichi radiali e assiali

### Output shaft

Albero di uscita

$n_2$ [min <sup>-1</sup> ]	FA [N]	FR [N]
700	294	1470
600	320	1600
400	370	1850
300	400	2000
200	460	2300
140	510	2550

$$F_{eq} = F_R \cdot \frac{47.5}{X + 22.5}$$

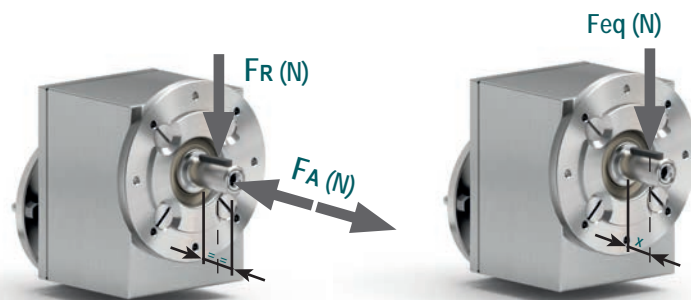

Tab. 1

Tab. 2

110  
Nm

511L

P511L-F ... Basic gearbox  
Riduttore base

Gearbox weight 9.0 kg  
Peso riduttore

M. flanges	Kit code	øF	k1
80 B14	KI854046	120	148.5
90 B14	KI854045	140	148.5
100-112 B14	KI854041	160	157.5

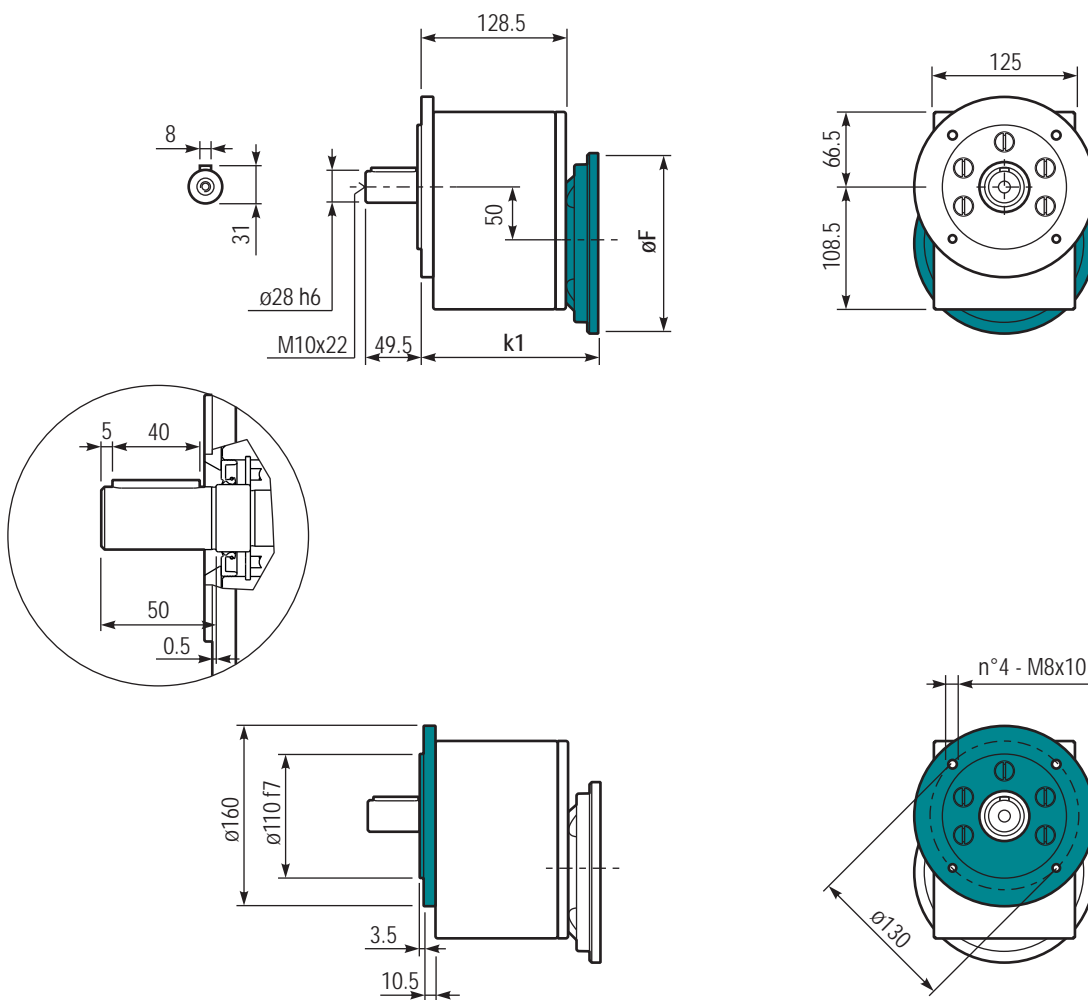



# **L** RCL series Stainless steel shielded coaxial gearboxes

*Riduttori coassiali schermati in acciaio inox*

Section **5**  
Sezione 5

This range is **CE** **NSF** certified  
COMPONENT

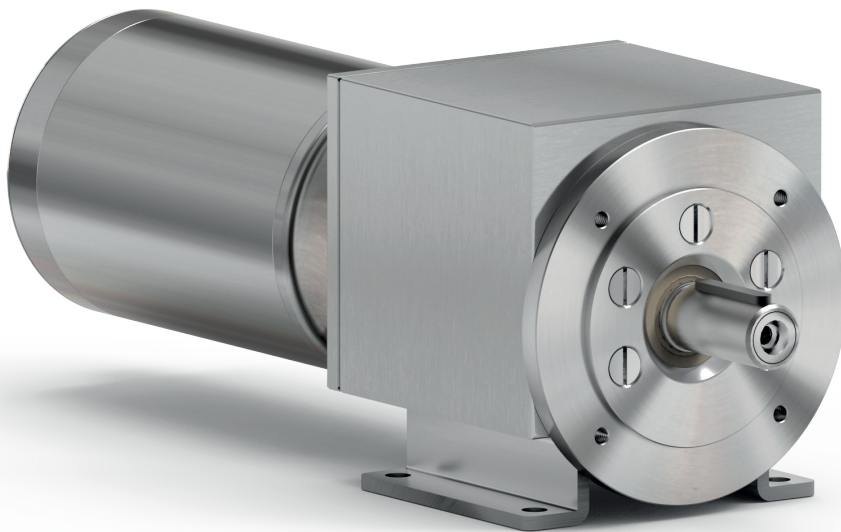

# FEATURES

Caratteristiche

## RCL series Stainless steel shielded coaxial gearboxes

Riduttori coassiali schermati in acciaio inox

Type <i>Tipo</i>	Torque <i>Coppia</i>	Center distance <i>Interasse</i>	Input power <i>Potenza in entrata</i>	Hollow output shaft <i>Albero cavo in uscita</i>
402L	160 Nm	-	0.37 ÷ 1.5 kW	ø25 mm
602L	520 Nm	-	1.1 ÷ 4.0 kW	ø35 mm

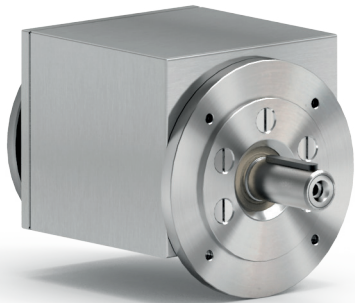

This product is:

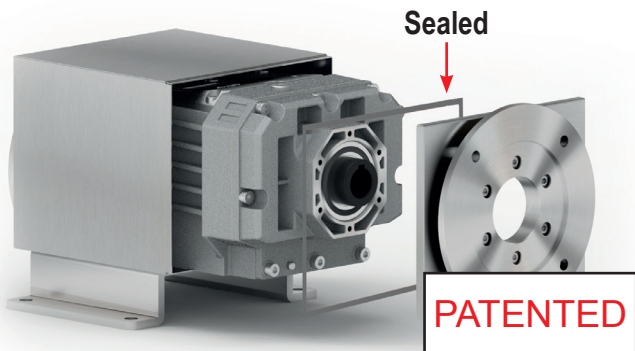

The "L" series is an already totally enclosed aluminum gearboxes, that is shielded and sealed by stainless steel 316L case.

La serie "L" è ottenuta da un riduttore in alluminio che viene incapsulato all'interno di un carter sigillato in inox 316L.

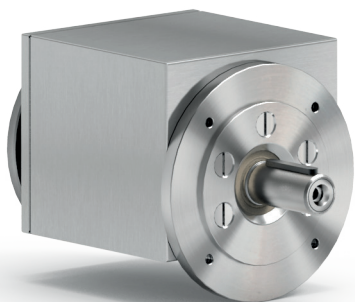

Output shaft is produced in AISI 316L.

Albero in uscita in AISI 316L.





**Fully modular IEC flanges and compact NEMA C motor flanges.**

*Flange IEC e NEMA completamente modulari.*

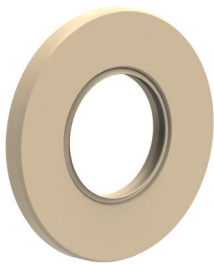

**Standard FPM (fkm) seals.**

*Anelli di tenuta FPM(fkm) standard.*





**Hardened and ground gears.**

*Ingranaggi temprati e rettificati.*

# How to order

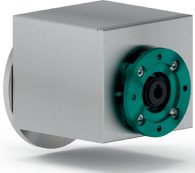
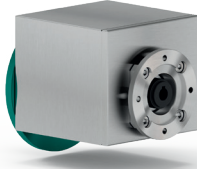
Codifica

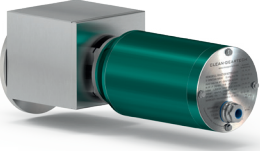
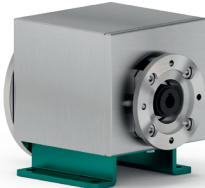
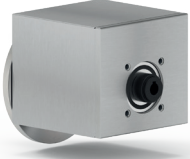
<b>P</b>	<b>402L</b>	<b>-F</b>	<b>3.52</b>	<b>C</b>
Type <i>Tipo</i>	Size <i>Grandezza</i>	Mounting <i>Montaggio</i>	Ratio <i>Rapporto</i>	Output shaft <i>Albero lento</i>
<b>P</b> 	<b>402L</b> <b>602L</b>	<b>-F</b> 	See technical data table <i>Vedi tabelle dati tecnici</i>	
<b>M</b> 				<b>402L</b> <b>V</b> -> $\varnothing 25$  <b>602L</b> <b>I</b> -> $\varnothing 35$
<b>B</b> 		<b>402L</b> <b>H1</b>  <b>602L</b> <b>H2</b>		

**4****-T****B3****E**

**With Type M specify terminal box position**  
*Con tipo M specificare posizione morsetteria*

**Output flange**  
*Flangia uscita*

**Motor size**  
*Grandezza motore*

**Mounting position**  
*Posizione di montaggio*

**Input bore**  
*Foro entrata*

**Terminal box position**  
*Posizione morsetteria*

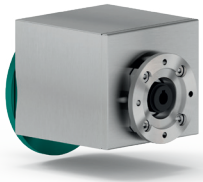

**Flange**  
*Flange*

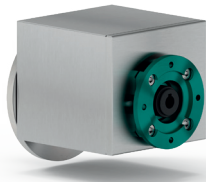
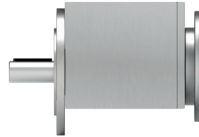
**B3**

**With coupling**  
*Con giunto*

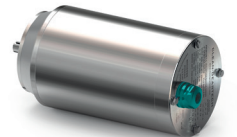
**A**

402L

IEC B14

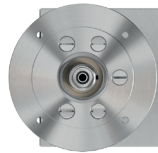
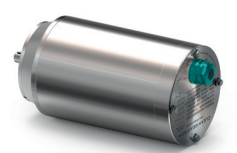
**-Q** -> 71 B14 (ø105)**-R** -> 80 B14 (ø120)**-T** -> 90 B14 (ø140)**-U** -> 100-122 B14 (ø160)**B6****B** -> 11mm**C** -> 14mm**D** -> 19mm**E** -> 24mm**F** -> 28mm**B**

**Without flange**  
*Senza flangia*

**-M** **With coupling**  
*Con giunto*

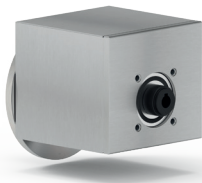
**B7**

**0** **Ready for input coupling**  
*Predisposto per giunto*

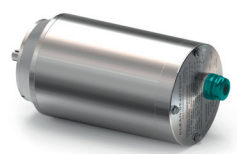
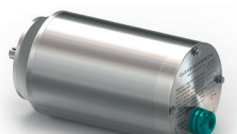
**C****B8****D****V5****V6****V8**

# Useful formulas

Formule utili

## Required power - Potenza richiesta

Lifting - Sollevamento

Rotation - Rotazione

Linear movement - Traslazione

$$P_{[kW]} = \frac{M_{[Kg]} \cdot g_{[9.81]} \cdot v_{[m/s]}}{1000}$$

$$P_{[kW]} = \frac{M_{[Nm]} \cdot n_{[rpm]}}{9550}$$

$$P_{[kW]} = \frac{F_{[N]} \cdot v_{[m/s]}}{1000}$$

## Torque - Coppia

$$M_{[Nm]} = \frac{9550 \cdot P_{[kW]}}{n_{[rpm]}}$$

$$M_{[lb\ in]} = \frac{63030 \cdot P_{[HP]}}{n_{[rpm]}}$$

## Radial loads - Carichi radiali

**Radial load generated by external transmissions keyed onto input and/or output shafts.**

Forza radiale generata da organi di trasmissione calettati sugli alberi di ingresso e/o uscita.

$$F_{R[N]} = \frac{M_{[Nm]} \cdot 2000}{d_{[mm]}} \cdot f_k$$

$$F_{R[N]} = \frac{M_{[lb\ in]} \cdot 8.9}{d_{[in]}} \cdot f_k$$

**M:** Output torque - *Momento torcente*

**d:** Diam. of driving element - *Diametro primitivo*

**f<sub>k</sub>:** Factor - *Coefficiente di trasformazione*

**1.15:** Gearwheels - *Ingranaggi*

**1.25:** Chain sprockets - *Catena*

**1.75:** Narrow v-belt pulley - *Cinghia Trapezoidale*

**2.50:** Flat-belt pulley - *Cinghia piatta*

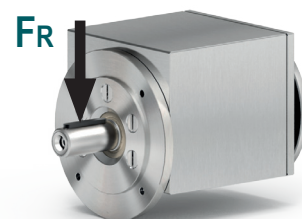

**If your application requires higher radial loads, contact our technical office. Higher loads may be possible.**

Nel caso la vostra applicazione richieda carichi radiali superiori consultare il nostro ufficio tecnico, valori maggiori possono essere accettati.

# How to select a gearbox

Come selezionare un riduttore

## A Select required torque (according to service factor)

Seleziona la coppia desiderata (comprensiva del fattore di servizio)

## B Select output speed

Seleziona la velocità in uscita

## C Select gear ratio in the line corresponding to the chosen motor power

Sulla riga corrispondente alla motorizzazione prescelta si può rilevare il rapporto di riduzione

## D Select motor flange available (if requested)

Scegli la flangia disponibile (se richiesta)

Gear size  
Grandezza  
riduttore

C

Ratio  
Rapporto

Transmitted torque  
Momento torcente  
trasmesse

Nominal power  
Potenza nominale

Flange code  
Codice flangia

Input speed  
Velocità in entrata

402L

160  
Nm



RCL series

Stainless steel shielded coaxial gearboxes

Riduttori coassiali schermati in acciaio inox

The dynamic efficiency is **0.96** for all ratios

Input speed ( $n_1$ ) = 1400 min<sup>-1</sup>

Output speed $n_2$ [min <sup>-1</sup> ]	Ratio $i$	Motor power $P_{1M}$ [kW]	Output torque $M_{2M}$ [Nm]	Service factor f.s	Nominal power $P_{1R}$ [kW]	Nominal torque $M_{2R}$ [Nm]	B5 motor flanges		B14 motor flanges			Output shaft  Standard ø25	Ratio code 
							-	-	-Q 71	-R 80	-T 90		
398	3.52	3	68	1.2	3.5	80			C	C		2821	01
321	4.37	3	84	1.1	3.1	90			C	C		2818	02
252	5.56	3	107	0.9	2.7	100			C	C		2813	03
220	6.36	2.2	90	1.1	2.3	95			C	C		1921	04
191	7.33	2.2	104	1.2	2.5	120			C	C		2812	05
177	7.89	2.2	112	1.1	2.3	120			C	C		1918	06
139	10.06	2.2	143	1.0	2.3	150			C	C		1913	08
120	11.66	1.5	114	1.5	2.3	174			C	C		1713	09
106	13.26	1.5	130	1.2	1.8	160			C	C		1912	10
...	...	...	...	...	...	...			...	...		...	...

B Output speed  
Velocità in uscita

Motor power  
Potenza motore

Service factor  
Fattore di servizio

A Nominal torque  
Momento torcente  
nominale

Output shaft diam.  
Diametro albero uscita

Notes  
Note

### Type of load and starts per hour

Tipo di carico e avviamenti per ora

Oper. hours per day  
Ore di funz. giorn.

		Oper. hours per day		
		3h	10h	24h
Continuous or intermittent application with start / hour Applicazione continua o intermittente con numero operazioni/ora	Uniform - <i>Uniforme</i>	0.8	1	1.25
	Moderate - <i>Moderato</i>	1	1.25	1.5
	Heavy - <i>Forte</i>	1.25	1.5	1.75
Intermittent application with start / hour Applicazione intermittente con numero operazioni/ora	Uniform - <i>Uniforme</i>	1	1.25	1.5
	Moderate - <i>Moderato</i>	1.25	1.5	1.75
	Heavy - <i>Forte</i>	1.5	1.75	2.15

D Motor flange available  
Flange disponibili

B) Mounting with reduction bushing  
Montaggio con boccola di riduzione

C) Motor flange holes position/terminal box position  
Posizione fori flangia/basetta motore

B) Available without reduction bushing  
Disponibile anche senza boccola

# 402L

## 160 Nm

### RCL series

# Stainless steel shielded coaxial gearboxes

Riduttori coassiali schermati in acciaio inox

The dynamic efficiency is **0.96** for all ratios

Input speed ( $n_1$ ) = 1400 min<sup>-1</sup>

Output speed $n_2$ [min <sup>-1</sup> ]	Ratio $i$	Motor power $P_{1M}$ [kW]	Output torque $M_{2M}$ [Nm]	Service factor $f_s$	Nominal power $P_{1R}$ [kW]	Nominal torque $M_{2R}$ [Nm]	B5 motor flanges		B14 motor flanges			Output shaft 	Ratio code
							-	-	-Q 71	-R 80	-T 90		
398	3.52	1.5	34	2.3	3.5	80			C	C		2821	01
321	4.37	1.5	43	2.1	3.1	90			C	C		2818	02
252	5.56	1.5	54	1.8	2.7	100			C	C		2813	03
220	6.36	1.5	62	1.5	2.3	95			C	C		1921	04
191	7.33	1.5	72	1.7	2.5	120			C	C		2812	05
177	7.89	1.5	77	1.6	2.3	120			C	C		1918	06
139	10.06	1.5	99	1.5	2.3	150			C	C		1913	08
120	11.66	1.5	114	1.5	2.3	174			C	C		1713	09
106	13.26	1.5	130	1.2	1.8	160			C	C		1912	10
102	13.68	1.5	134	1.1	1.6	144			C	C		1513	25
91	15.37	1.5	151	1.1	1.6	160			C	C		1712	11
86	16.20	1.5	159	0.9	1.3	138			C	C	Standard ø25	1910	12
78	18.04	1.5	177	0.9	1.4	160			C	C		1512	23
75	18.78	1.1	134	1.0	1.1	138			C	C		1710	24
65	21.54	1.1	154	1.0	1.1	160			C	C		1312	14
63	22.29	1.1	160	1.0	1.1	167			C	C		1013	15
53	26.31	0.75	129	1.1	0.80	138			C	C		1310	16
47.6	29.40	0.75	144	1.1	0.83	160			C	C		1012	17
39	35.91	0.55	130	1.1	0.59	138			C	C		1010	18
36.5	38.37	0.55	139	1.2	0.64	160			C	C		912	19
29.9	46.87	0.55	170	0.8	0.45	138			C	C		910	20
27.6	50.67	0.37	123	1.1	0.40	132			C	C	712	21	
22.6	61.89	0.37	150	0.9	0.34	138			C	C	710	22	

**Motor flanges available**  
Flange motore disponibili

**B) Supplied with reduction bushing**  
Fornito con bussola di riduzione

**B) Available on request without reduction bushing**  
Disponibile a richiesta senza bussola di riduzione

**C) Motor flange holes position**  
Posizione fori flangia motore

## Lubrication

Lubrificazione

**Always specify the mounting position**

Specificare sempre la posizione di montaggio

Unit 402L is supplied with synthetic oil to assure long life lubrication.  
Food grade oil is available on request.

See Table 1 for lubrication and recommended quantity.





See Table 2 for possible radial and axial loads on the gearbox.

Il riduttore tipo 402L viene fornito con olio sintetico e lubrificazione tipo "long life".

Disponibile a richiesta olio alimentare.

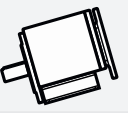
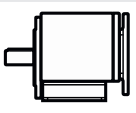
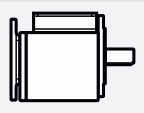
Vedi Tabella 1 per oli e quantità consigliati.

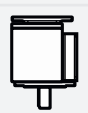
Vedi Tabella 2 per i carichi radiali e assiali applicabili al riduttore.

<b>Agip</b> Tellium VSF 320	<b>Shell</b> Omala S4 WE 320	<b>V8</b> On request ASK	
<b>B3</b> Standard 0.25 LT		<b>B8</b> On request 0.40 LT	
<b>B6</b> On request 0.30 LT		<b>V5</b> On request 0.40 LT	
<b>B7</b> On request 0.40 LT		<b>V6</b> On request 0.50 LT	

Tab. 1

## Radial and axial loads

Carichi radiali e assiali

### Output shaft

Albero di uscita

$n_2$ [min <sup>-1</sup> ]	$F_A$ [N]	$F_R$ [N]
300	310	1550
250	330	1650
200	360	1800
140	406	2030
120	448	2240
85	480	2400
70	540	2700
40	600	3000
15	600	3000

$$F_{eq} = F_R \cdot \frac{51}{X + 21}$$

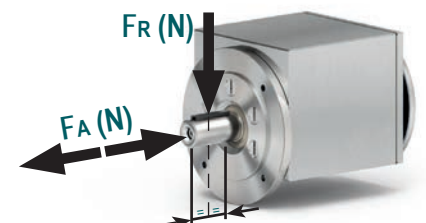
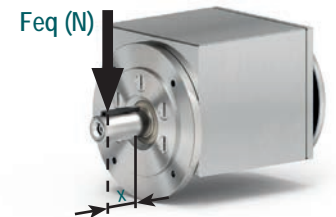

Tab. 2

160  
Nm

402L

P402L-F.. Basic gearbox  
Riduttore base

Gearbox weight 9.2 kg  
Peso riduttore

M. flanges	Kit code	øF	k1
71B14	KI634047	105	179.5
80B14	KI634046	120	180.5
90B14	KI634041	140	181.5

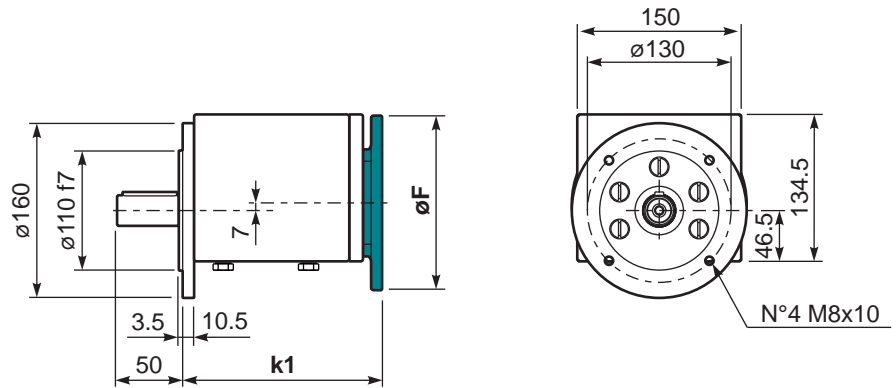

P402LH1.. Feet  
Piedini

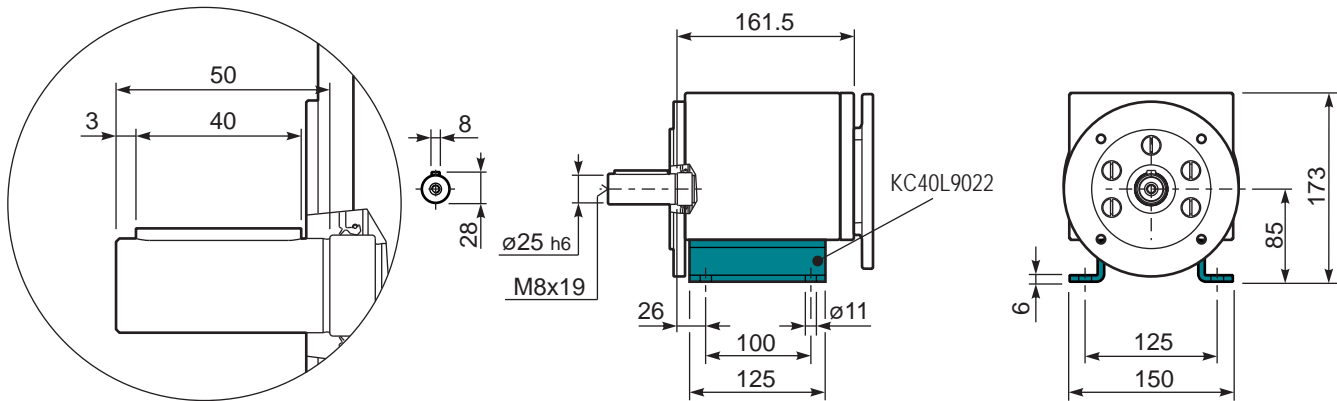

P402L-F.. Basic gearbox  
Riduttore base

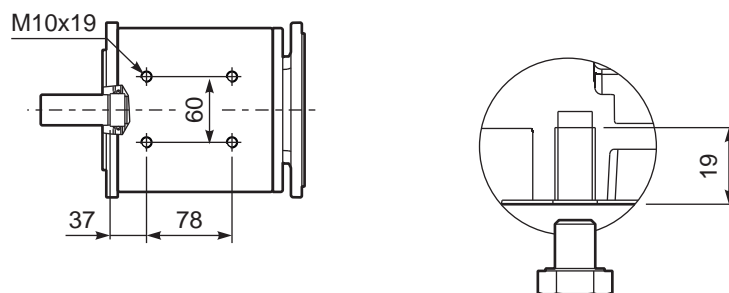

For direct mounting  
of the gearboxes  
remove the 4 screws  
Per un montaggio diretto  
con il riduttore rimuovere le 4 viti

# 602L

## 520 Nm

### RCL series

# Stainless steel shielded coaxial gearboxes

Riduttori coassiali schermati in acciaio inox

The dynamic efficiency is **0.96** for all ratios

Input speed ( $n_1$ ) = 1400 min<sup>-1</sup>

Output speed $n_2$ [min <sup>-1</sup> ]	Ratio $i$	Motor power $P_{1M}$ [kW]	Output torque $M_{2M}$ [Nm]	Service factor $f_s$	Nominal power $P_{1R}$ [kW]	Nominal torque $M_{2R}$ [Nm]	B5 motor flanges				B14 motor flanges			Output shaft 	Ratio code
							-	-	-	-	-R	-T	-U		
388	3.61	4	93	1.9	7.6	180								3018	01
331	4.23	4	108	2.0	8.0	220								3016	02
279	5.01	4	129	2.0	7.9	260								3014	03
231	6.07	4	156	1.9	7.6	300								3012	04
206	6.81	4	175	2.0	7.9	350								2018	05
176	7.96	4	204	1.8	7.1	370								2016	07
148	9.45	4	242	1.7	6.5	400								2014	08
122	11.43	4	293	1.4	5.5	415								2012	09
100	14.00	4	359	1.2	4.7	435								1316	10
84	16.62	4	426	1.2	4.7	515								1314	11
70	20.10	4	515	1.0	4.0	520								1312	12
57	24.61	3	475	1.1	3.2	520								1112	20
47.6	29.41	2.2	418	1.1	2.3	450								814	14
39.3	35.58	2.2	506	1.0	2.2	520								812	15
34.6	40.50	1.1	290	1.1	1.2	320								614	16
31.7	44.23	1.5	433	0.9	1.4	400								810	17
28.6	49.00	1.1	351	1.1	1.2	400								612	18
23.0	60.90	1.1	436	0.9	1.0	400								610	19

**Motor flanges available**  
Flange motore disponibili

**B) Supplied with reduction bushing**  
Fornito con bussola di riduzione

**B) Available on request without reduction bushing**  
Disponibile a richiesta senza bussola di riduzione

**C) Motor flange holes position**  
Posizione fori flangia motore

## Lubrication

Lubrificazione

Always specify the mounting position

Specificare sempre la posizione di montaggio

Unit 602L is supplied with synthetic oil to assure long life lubrication.  
Food grade oil is available on request.

See Table 1 for lubrication and recommended quantity.





See Table 2 for possible radial and axial loads on the gearbox.

Il riduttore tipo 602L viene fornito con olio sintetico e lubrificazione tipo "long life".

Disponibile a richiesta olio alimentare.

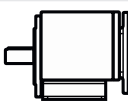
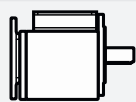
Vedi Tabella 1 per oli e quantità consigliati.

Vedi Tabella 2 per i carichi radiali e assiali applicabili al riduttore.

Agip	Shell	V8	
Telium VSF 320	Omala S4 WE 320	On request ASK	
B3		B8	
Standard 0.55 LT		On request 1.20 LT	
B6		V5	
On request 0.85 LT		On request 1.20 LT	
B7		V6	
On request 1.10 LT		On request 1.25 LT	

## Radial and axial loads

Carichi radiali e assiali

### Output shaft

Albero di uscita

$n_2$ [min <sup>-1</sup> ]	$F_A$ [N]	$F_R$ [N]
300	560	2800
250	600	3000
200	640	3200
140	740	3700
120	760	3800
85	840	4000
70	890	4200
40	1160	5800
15	1300	6500

$$F_{eq} = F_R \cdot \frac{60.5}{X + 25.5}$$

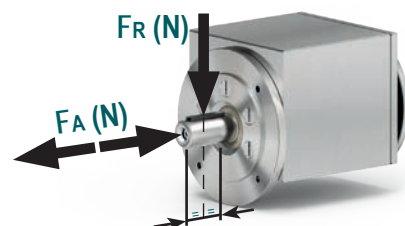
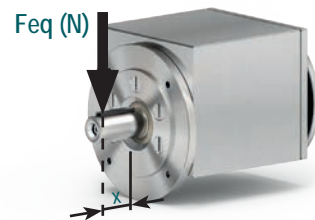

Tab. 1

Tab. 2



520  
Nm

602L

P602L-F..

Basic gearbox  
Riduttore base

Gearbox weight  
Peso riduttore 18.5 kg

M. flanges	Kit code	øF	k1
80 B14	KI854046	120	247
90 B14	KI854045	140	247
100-112 B14	KI854041	160	256

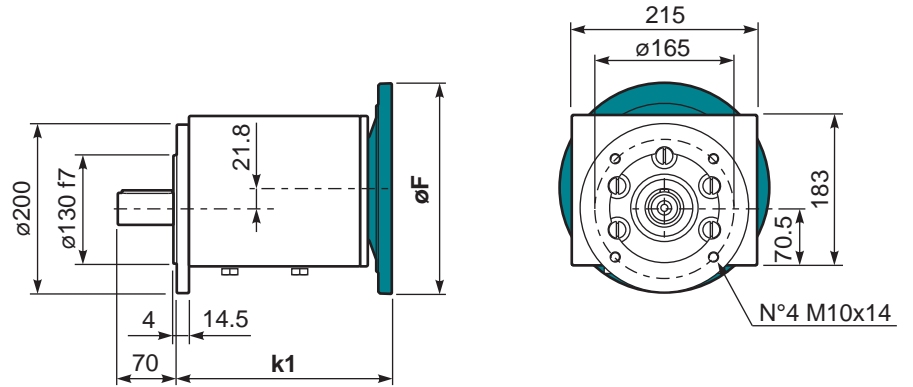

P602LH2..

Feet  
Piedini

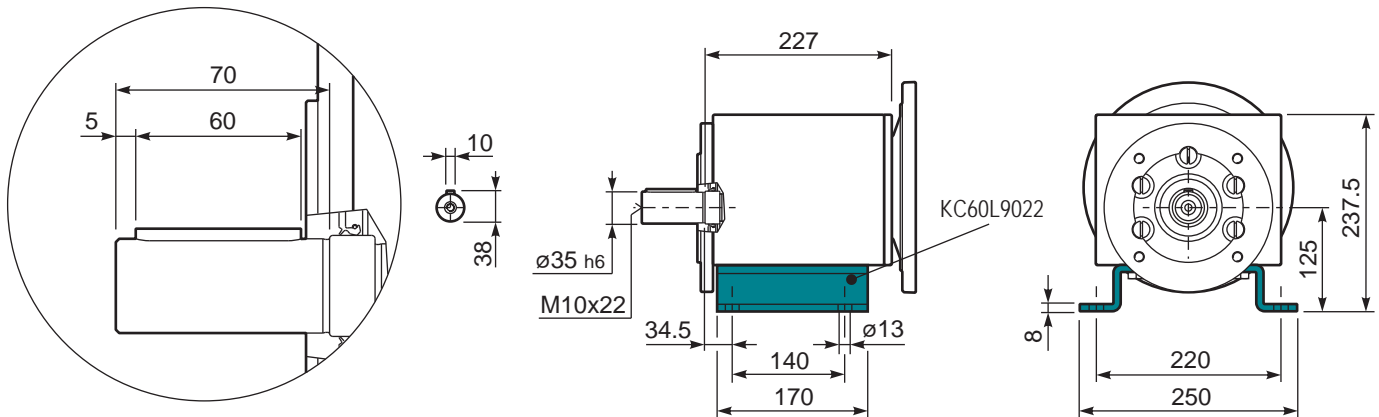

P602L-F..

Basic gearbox  
Riduttore base

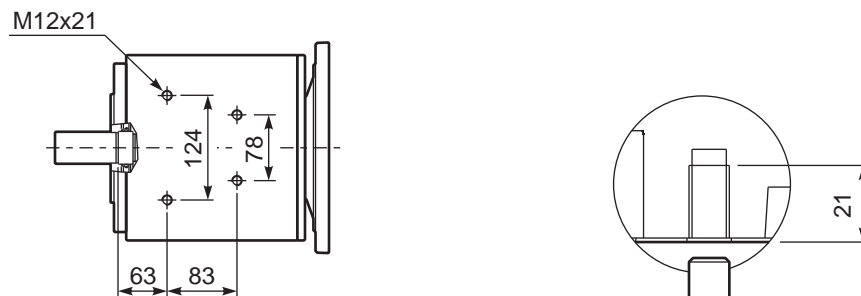



For direct mounting  
of the gearboxes  
remove the 4 screws  
Per un montaggio diretto  
con il riduttore rimuovere le 4 viti



# L BVL series Stainless steel shielded helical bevel gearboxes

*Riduttori a coppia conica schermati in acciaio inox*

Section **6**  
Sezione 6

This range is    certified



# FEATURES

Caratteristiche

## BVL series

# Stainless steel shielded helical bevel gearboxes

Riduttori a coppia conica schermati in acciaio inox

Type Tipo	Torque Coppia	Center distance Interasse	Input power Potenza in entrata	Hollow output shaft Albero cavo in uscita
X22L	50 Nm	-	0.12 ÷ 0.37 kW	ø20
X32L	90 Nm	-	0.25 ÷ 1.5 kW	ø20
X42L	150 Nm	-	0.25 ÷ 1.5 kW	ø25
X52L	250 Nm	-	0.55 ÷ 3.0 kW	ø30
X62L	410 Nm	-	0.75 ÷ 4.0 kW	ø35

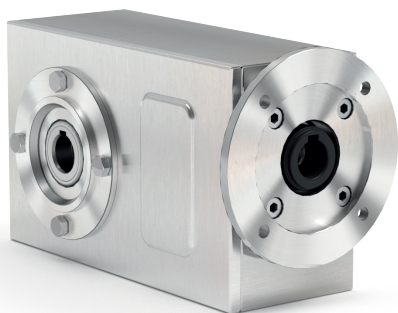

This product is:

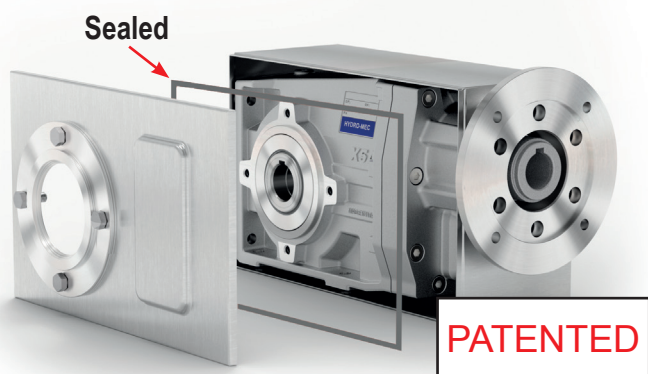

The "L" series is an already totally enclosed aluminum gearboxes, that is shielded and sealed by stainless steel 316L case.

La serie "L" è ottenuta da un riduttore in alluminio che viene incapsulato all'interno di un carter sigillato in inox 316L.



Output shaft is produced in AISI 316L.

Albero in uscita in AISI 316L.



**Protection cap in AISI 316L.**

*Coperchietto di protezione in AISI 316L.*



**Fully modular IEC flanges and compact NEMA C motor flanges.**

*Flange IEC e NEMA completamente modulari.*

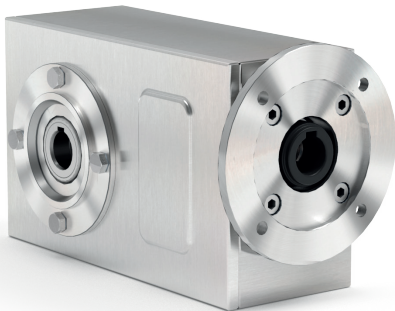

**Stainless steel 316L hollow output shaft.  
Viton seals with stainless steel 316L shield.**



*Albero cavo in uscita in acciaio inox AISI 316L. Anelli di tenuta in viton con schermo protettivo in acciaio inox AISI 316L.*











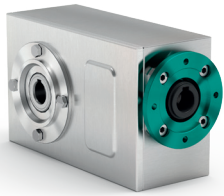
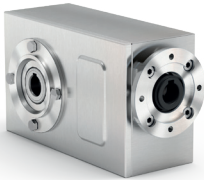
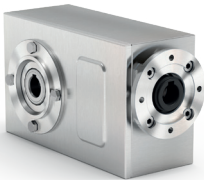
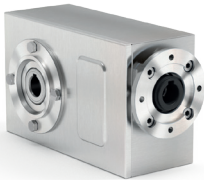

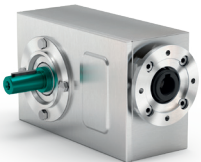
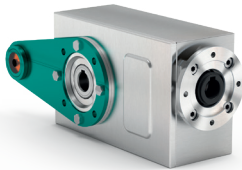
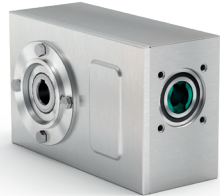
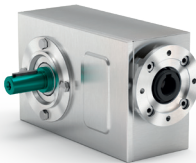
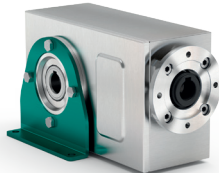

**Hardened and ground gears.**

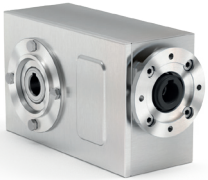
*Ingranaggi temprati e rettificati.*

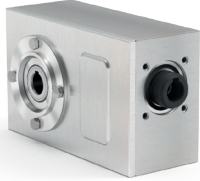
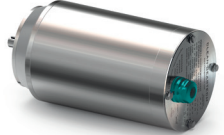
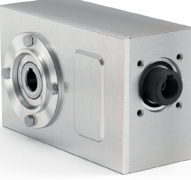
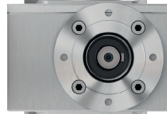
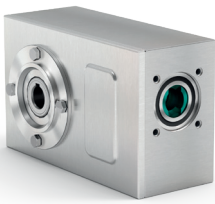
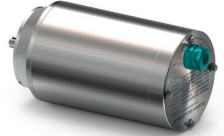
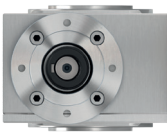
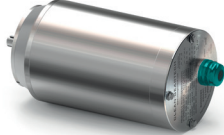
# How to order

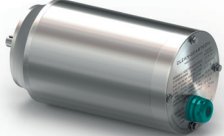
Codifica

<b>M</b>	<b>X42L</b>	<b>I</b>	<b>7.29</b>	<b>-C</b>	<b>BR</b>
Type <i>Tipo</i>	Size <i>Grandezza</i>	Hub <i>Mozzo</i>	Ratio <i>Rapporto</i>	Output shaft <i>Albero uscita</i>	Type <i>Tipo</i>
<p><b>P</b></p> 	<p><b>X22L</b> <b>X32L</b> <b>X42L</b> <b>X52L</b> <b>X62L</b></p>	<p><b>I</b> Hollow output shaft <i>Foro albero uscita</i></p> 	<p>See technical data table <i>Vedi tabelle dati tecnici</i></p>	<p>Hollow output shaft <i>Foro albero uscita</i></p> 	<p><b>FB</b> Universal <i>Forma base</i></p> 
<p><b>M</b></p> 		<p><b>A</b> Single output shaft <i>Albero uscita singolo</i></p> 		<p>X22L X32L <b>-B</b> → <math>\varnothing 20</math> X42L <b>-C</b> → <math>\varnothing 25</math> X52L <b>-D</b> → <math>\varnothing 30</math> X62L <b>-E</b> → <math>\varnothing 35</math></p>	<p><b>BR</b> Reaction arm <i>Braccio di reazione</i></p> 
<p><b>B</b></p> 				<p>Single output shaft <i>Albero uscita singolo</i></p> 	<p><b>PA</b></p> 
				<p>X22L X32L <b>-I</b> → <math>\varnothing 20</math> X42L <b>-L</b> → <math>\varnothing 25</math> X52L <b>-M</b> → <math>\varnothing 30</math> X62L <b>-N</b> → <math>\varnothing 35</math></p>	<p><b>PV</b></p> 

<b>N</b>	<b>-T</b>	<b>B3</b>	<b>E</b>	With Type M specify terminal box position <i>Con tipo M specificare posizione morsettiere</i>
Output flange <i>Flangia in uscita</i>	Motor size <i>Grandezza motore</i>	Mounting position <i>Posizione di montaggio</i>	Input bore <i>Foro entrata</i>	Terminal box position <i>Posizione morsettiere</i>
<p><b>N</b> Without flange <i>Senza flangia</i></p> 	<p><b>Flange</b> <i>Flange</i></p>  <p><b>IEC B14</b></p> <ul style="list-style-type: none"> <li>-P -&gt; 63 B14 (ø90)</li> <li>-Q -&gt; 71 B14 (ø105)</li> <li>-R -&gt; 80 B14 (ø120)</li> <li>-T -&gt; 90 B14 (ø140)</li> <li>-U -&gt; 100÷112 B14 (ø160)</li> </ul>	<p><b>B3</b></p> 	<p><b>With coupling</b> <i>Con giunto</i></p>  <p><b>B</b> -&gt; 11mm <b>C</b> -&gt; 14mm <b>D</b> -&gt; 19mm <b>E</b> -&gt; 24mm <b>F</b> -&gt; 28mm</p>	<p><b>A</b></p> 
<p><b>Without flange</b> <i>Senza flangia</i></p> <p><b>-M</b> With coupling <i>Con giunto</i></p> 		<p><b>B6</b></p> 	<p><b>0</b> Ready for input coupling <i>Predisposto per giunto</i></p> 	<p><b>B</b></p> 
		<p><b>B7</b></p> 		<p><b>C</b></p> 
		<p><b>B8</b></p> 		<p><b>D</b></p> 
		<p><b>V5</b></p> 		
		<p><b>V6</b></p> 		
		<p><b>V8</b></p> 		

# Useful formulas

Formule utili

## Required power - Potenza richiesta

Lifting - Sollevamento

Rotation - Rotazione

Linear movement - Traslazione

$$P_{[kW]} = \frac{M_{[Kg]} \cdot g_{[9.81]} \cdot v_{[m/s]}}{1000}$$

$$P_{[kW]} = \frac{M_{[Nm]} \cdot n_{[rpm]}}{9550}$$

$$P_{[kW]} = \frac{F_{[N]} \cdot v_{[m/s]}}{1000}$$

## Torque - Coppia

$$M_{[Nm]} = \frac{9550 \cdot P_{[kW]}}{n_{[rpm]}}$$

$$M_{[lb\ in]} = \frac{63030 \cdot P_{[HP]}}{n_{[rpm]}}$$

## Radial loads - Carichi radiali

Radial load generated by external transmissions keyed onto input and/or output shafts.

Forza radiale generata da organi di trasmissione calettati sugli alberi di ingresso e/o uscita.

$$F_{R[N]} = \frac{M_{[Nm]} \cdot 2000}{d_{[mm]}} \cdot f_k$$

$$F_{R[N]} = \frac{M_{[lb\ in]} \cdot 8.9}{d_{[in]}} \cdot f_k$$

**M:** Output torque - *Momento torcente*

**d:** Diam. of driving element - *Diametro primitivo*

**f<sub>k</sub>:** Factor - *Coefficiente di trasformazione*

1.15: Gearwheels - *Ingranaggi*

1.25: Chain sprockets - *Catena*

1.75: Narrow v-belt pulley - *Cinghia Trapezoidale*

2.50: Flat-belt pulley - *Cinghia piatta*

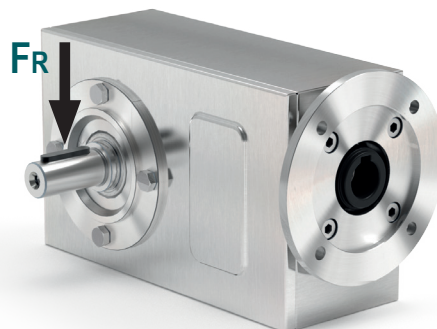

If your application requires higher radial loads, contact our technical office. Higher loads may be possible.

Nel caso la vostra applicazione richieda carichi radiali superiori consultare il nostro ufficio tecnico, valori maggiori possono essere accettati.



# How to select a gearbox

Come selezionare un riduttore

## A Select required torque (according to service factor)

Seleziona la coppia desiderata (comprensiva del fattore di servizio)

## B Select output speed

Seleziona la velocità in uscita

## C Select gear ratio in the line corresponding to the chosen motor power

Sulla riga corrispondente alla motorizzazione prescelta si può rilevare il rapporto di riduzione

## D Select motor flange available (if requested)

Scegli la flangia disponibile (se richiesta)

Gear size  
Grandezza  
riduttore

C

Ratio  
Rapporto

Transmitted torque  
Momento torcente  
trasmesso

Nominal power  
Potenza nominale

Flange code  
Codice flangia

Input speed  
Velocità in entrata

X22L

50  
Nm



BVL series

Stainless steel shielded helical bevel gearboxes

Riduttori a coppia conica schermati in acciaio inox

The dynamic efficiency is **0.96** for all ratios

Input speed ( $n_1$ ) = 1400 min<sup>-1</sup>

Output speed $n_2$ [min <sup>-1</sup> ]	Ratio $i$	Motor power $P_{1M}$ [kW]	Output torque $M_{2M}$ [Nm]	Service factor f.s.	Nominal power $P_{1R}$ [kW]	Nominal torque $M_{2R}$ [Nm]	B5 motor flanges		B14 motor flanges		Output shaft 	Ratio code 
							-	-	-P 63	-Q 71		
290	<b>4.83</b>	0.37	12	2.6	<b>0.95</b>	<b>30</b>			C		289	01
189	<b>7.40</b>	0.37	18	1.7	<b>0.62</b>	<b>30</b>			C		287	02
146	<b>9.58</b>	0.37	23	1.7	<b>0.64</b>	<b>40</b>			C		199	03
128	<b>10.98</b>	0.37	27	1.7	<b>0.63</b>	<b>45</b>			C		179	04
107	<b>13.07</b>	0.37	32	1.4	<b>0.53</b>	<b>45</b>			C		159	05
95	<b>14.66</b>	0.37	35	1.3	<b>0.47</b>	<b>45</b>			C	Standard ø20	197	06
89	<b>15.79</b>	0.37	38	1.2	<b>0.44</b>	<b>45</b>			C		139	07
83	<b>16.81</b>	0.37	41	1.1	<b>0.41</b>	<b>45</b>			C		177	08
70	<b>20.00</b>	0.37	48	1.0	<b>0.37</b>	<b>48</b>			C		157	09
...	...	...	...	...	...	...			...		...	...

B Output speed  
Velocità in uscita

Motor power  
Potenza motore

Service factor  
Fattore di servizio

A Nominal torque  
Momento torcente  
nominale

Output shaft diam.  
Diametro albero uscita

Notes  
Note

### Type of load and starts per hour

Tipo di carico e avviamenti per ora

### Oper. hours per day

Ore di funz. giorn.

		Oper. hours per day		
		3h	10h	24h
Continuous or intermittent application with start / hour Applicazione continua o intermittente con numero operazioni/ora	Uniform - <i>Uniforme</i>	0.8	1	1.25
	Moderate - <i>Moderato</i>	1	1.25	1.5
	Heavy - <i>Forte</i>	1.25	1.5	1.75
Intermittent application with start / hour Applicazione intermittente con numero operazioni/ora	Uniform - <i>Uniforme</i>	1	1.25	1.5
	Moderate - <i>Moderato</i>	1.25	1.5	1.75
	Heavy - <i>Forte</i>	1.5	1.75	2.15

D Motor flange available  
Flange disponibili

B) Mounting with reduction bushing  
Montaggio con boccia di riduzione

C) Motor flange holes position/terminal box position  
Posizione fori flangia/basetta motore

B) Available without reduction bushing  
Disponibile anche senza boccia

The dynamic efficiency is **0.96** for all ratios

Input speed ( $n_1$ ) = 1400 min<sup>-1</sup>

Output speed $n_2$ [min <sup>-1</sup> ]	Ratio $i$	Motor power $P_{1M}$ [kW]	Output torque $M_{2M}$ [Nm]	Service factor $f_s$	Nominal power $P_{1R}$ [kW]	Nominal torque $M_{2R}$ [Nm]	B5 motor flanges		B14 motor flanges		Output shaft 	Ratio code
							-	-	-P 63	-Q 71		
290	<b>4.83</b>	0.37	12	2.6	<b>0.95</b>	<b>30</b>			C		289	01
189	<b>7.40</b>	0.37	18	1.7	<b>0.62</b>	<b>30</b>			C		287	02
146	<b>9.58</b>	0.37	23	1.7	<b>0.64</b>	<b>40</b>			C		199	03
128	<b>10.98</b>	0.37	27	1.7	<b>0.63</b>	<b>45</b>			C		179	04
107	<b>13.07</b>	0.37	32	1.4	<b>0.53</b>	<b>45</b>			C		159	05
95	<b>14.66</b>	0.37	35	1.3	<b>0.47</b>	<b>45</b>			C		197	06
89	<b>15.79</b>	0.37	38	1.2	<b>0.44</b>	<b>45</b>			C		139	07
83	<b>16.81</b>	0.37	41	1.1	<b>0.41</b>	<b>45</b>			C		177	08
70	<b>20.00</b>	0.37	48	1.0	<b>0.37</b>	<b>48</b>			C		157	09
64	<b>21.93</b>	0.37	53	0.9	<b>0.35</b>	<b>50</b>			C		109	10
58	<b>24.18</b>	0.25	39	1.3	<b>0.32</b>	<b>50</b>			C		137	11
48.2	<b>29.04</b>	0.25	47	1.1	<b>0.26</b>	<b>50</b>			C		99	12
41.7	<b>33.57</b>	0.18	42	1.2	<b>0.23</b>	<b>50</b>			C		107	13
36.2	<b>38.67</b>	0.18	48	1.0	<b>0.20</b>	<b>50</b>			C		79	14
31.5	<b>44.44</b>	0.18	55	0.9	<b>0.17</b>	<b>50</b>			C		97	15
23.7	<b>59.18</b>	0.12	48	1.0	<b>0.13</b>	<b>50</b>			C		77	16
19.9	<b>70.24</b>	0.12	57	0.9	<b>0.11</b>	<b>50</b>			C		67	17

-  **Motor flanges available**  
Flange motore disponibili
-  **B) Supplied with reduction bushing**  
Fornito con bussola di riduzione
- B) Available on request without reduction bushing**  
Disponibile a richiesta senza bussola di riduzione
-  **C) Motor flange holes position**  
Posizione fori flangia motore

## Lubrication

Lubrificazione

Always specify the mounting position  
Specificare sempre la posizione di montaggio

Unit X22L is supplied with synthetic oil to assure long life lubrication.  
Food grade oil is available on request.

See Table 1 for lubrication and recommended quantity.

See Table 2 for possible radial and axial loads on the gearbox.

Il riduttore tipo X22L viene fornito con olio sintetico e lubrificazione tipo "long life".

Disponibile a richiesta olio alimentare.

Vedi Tabella 1 per oli e quantità consigliati.

Vedi Tabella 2 per i carichi radiali e assiali applicabili al riduttore.

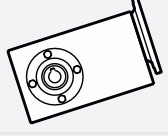
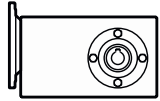
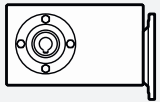
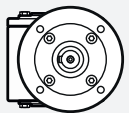
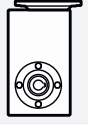
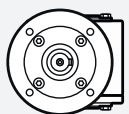
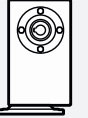
Agip	Shell	V8	
Telium VSF 320	Omala S4 WE 320	On request ASK	
B3		B8	
Standard 0.25 LT		On request 0.25 LT	
B6		V5	
On request 0.25 LT		On request 0.43 LT	
B7		V6	
On request 0.25 LT		On request 0.31 LT	

## Radial and axial loads

Carichi radiali e assiali

### Output shaft

Albero di uscita

$n_2$ [min <sup>-1</sup> ]	$F_A$ [N]	$F_R$ [N]
400	360	1800
250	380	1900
150	420	2100
100	440	2200
75	440	2200
50	440	2200
25	440	2200
15	440	2200

$$F_{eq} = F_R \cdot \frac{42}{X + 23}$$

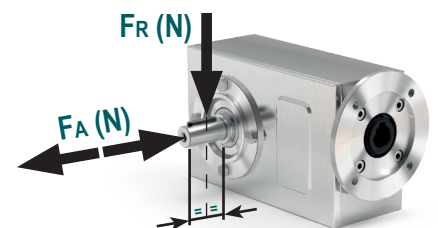
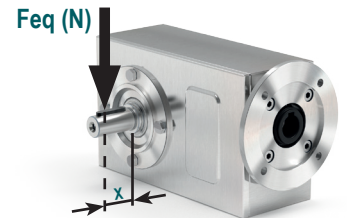

Tab. 1

Tab. 2

50  
Nm

X22L

**P<sub>X22L...</sub>** Basic gearbox  
*Riduttore base*

M. flanges	Kit code	øF	A
63B14	KI504047	90	155
71B14	KI504045	105	152.5

**Gearbox weight** 7.0 kg  
*Peso riduttore*

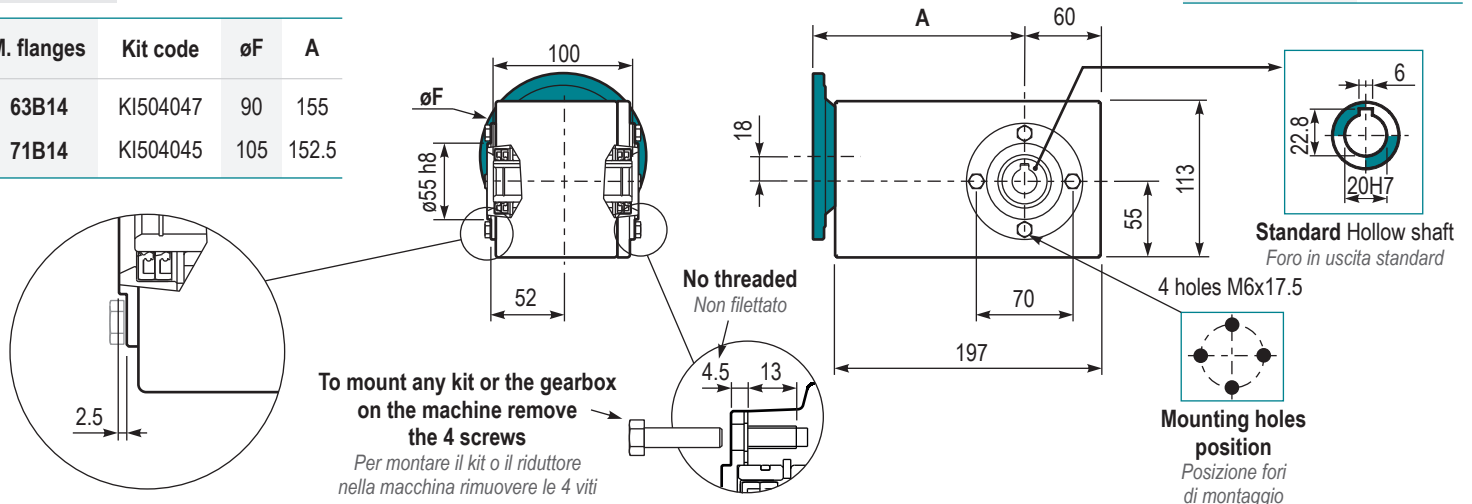

**PX22L PA..** Feet  
*Piedini*

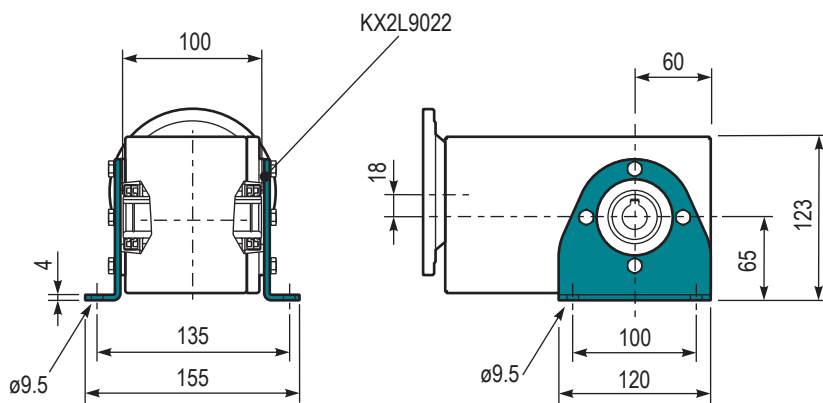

**PX22L PV..** Feet  
*Piedini*

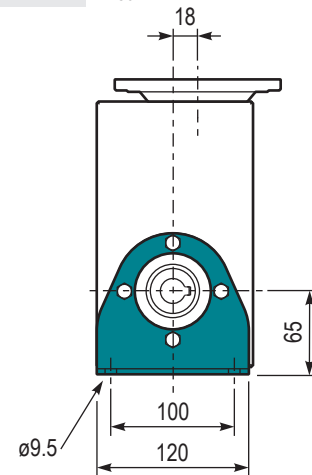

**PX22L A..** Single output shaft  
*Albero semplice in uscita*

cod. X2L0209  
**Protection cap ( on request )**  
*A richiesta coperchio di protezione*

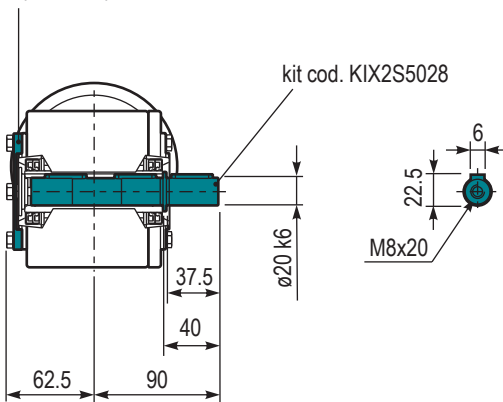

**PX22L BR..** Reaction Arm  
*Braccio di reazione*

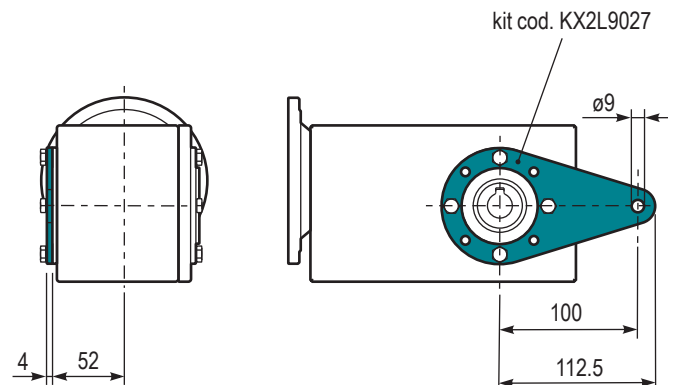

The dynamic efficiency is **0.96** for all ratios

Input speed ( $n_1$ ) = 1400 min<sup>-1</sup>

Output speed $n_2$ [min <sup>-1</sup> ]	Ratio $i$	Motor power $P_{1M}$ [kW]	Output torque $M_{2M}$ [Nm]	Service factor $f.s$	Nominal power $P_{1R}$ [kW]	Nominal torque $M_{2R}$ [Nm]	B5 motor flanges		B14 motor flanges			Output shaft 	Ratio code
							-	-	-Q 71	-R 80	-T 90		
191	<b>7.33</b>	1.5	72	1.0	<b>1.5</b>	<b>70</b>			C	C		289	01
125	<b>11.22</b>	1.1	80	1.1	<b>1.2</b>	<b>85</b>			C	C		287	02
106	<b>13.26</b>	1.1	95	0.9	<b>0.98</b>	<b>85</b>			C	C		199	03
91	<b>15.37</b>	1.1	110	0.8	<b>0.89</b>	<b>90</b>			C	C		179	04
78	<b>18.04</b>	0.75	89	1.0	<b>0.76</b>	<b>90</b>			C	C		159	05
69	<b>20.30</b>	0.75	100	0.9	<b>0.68</b>	<b>90</b>			C	C		197	06
65	<b>21.54</b>	0.75	106	0.9	<b>0.64</b>	<b>90</b>			C	C		139	07
59	<b>23.53</b>	0.55	85	1.1	<b>0.58</b>	<b>90</b>			C	C	Standard ø20	177	08
51	<b>27.62</b>	0.55	100	0.9	<b>0.50</b>	<b>90</b>			C	C		157	09
47.6	<b>29.40</b>	0.55	106	0.8	<b>0.47</b>	<b>90</b>			C	C		109	10
42.5	<b>32.97</b>	0.37	80	1.1	<b>0.42</b>	<b>90</b>			C	C		137	11
36.5	<b>38.37</b>	0.37	93	1.0	<b>0.36</b>	<b>90</b>			C	C		99	12
31.1	<b>45.00</b>	0.25	73	1.2	<b>0.31</b>	<b>90</b>			C	C		107	13
27.6	<b>50.67</b>	0.25	83	1.1	<b>0.27</b>	<b>90</b>			C	C		79	14
23.8	<b>58.73</b>	0.25	96	0.9	<b>0.23</b>	<b>90</b>			C	C		97	15
18.1	<b>77.55</b>	0.25*	127	0.7	<b>0.18</b>	<b>90</b>			C	C		77	16

\* Power higher than the maximum one which can be supported by the gearbox. Select according to the torque  $M_{2R}$

Potenza superiore a quella massima sopportabile dal riduttore. Selezionare in base al momento torcente  $M_{2R}$

-  **Motor flanges available**  
Flange motore disponibili
-  **B) Supplied with reduction bushing**  
Fornito con bussola di riduzione
-  **B) Available on request without reduction bushing**  
Disponibile a richiesta senza bussola di riduzione
-  **C) Motor flange holes position**  
Posizione fori flangia motore

## Lubrication

Lubrificazione

Always specify the mounting position

Specificare sempre la posizione di montaggio

Unit X32L is supplied with synthetic oil to assure long life lubrication.

Food grade oil is available on request.

See Table 1 for lubrication and recommended quantity.

See Table 2 for possible radial and axial loads on the gearbox.

Il riduttore tipo X32L viene fornito con olio sintetico e lubrificazione tipo "long life".

Disponibile a richiesta olio alimentare.

Vedi Tabella 1 per oli e quantità consigliati.

Vedi Tabella 2 per i carichi radiali e assiali applicabili al riduttore.

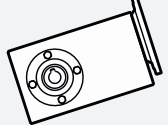
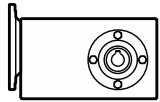
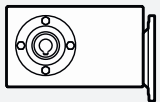
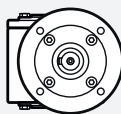
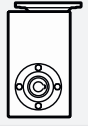
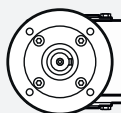
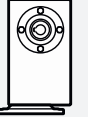
<b>Agip</b> Telium VSF 320	<b>Shell</b> Omala S4 WE 320	<b>V8</b> On request ASK	
<b>B3</b> Standard 0.40 LT		<b>B8</b> On request 0.60 LT	
<b>B6</b> On request 0.60 LT		<b>V5</b> On request 0.85 LT	
<b>B7</b> On request 0.40 LT		<b>V6</b> On request 0.60 LT	

Tab. 1

## Radial and axial loads

Carichi radiali e assiali

### Output shaft

Albero di uscita

$n_2$ [min <sup>-1</sup> ]	$F_A$ [N]	$F_R$ [N]
250	400	2000
150	450	2250
100	500	2500
75	560	2800
50	560	2800
25	560	2800
15	560	2800

$$F_{eq} = F_R \cdot \frac{47.5}{X + 28.5}$$

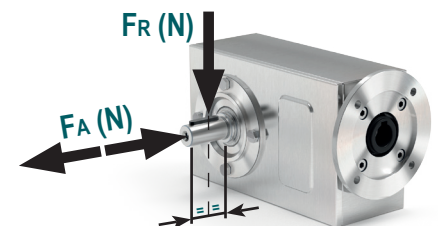
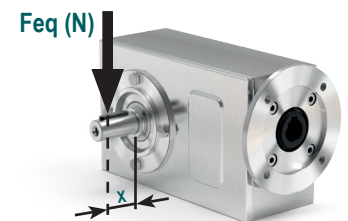

Tab. 2

90  
Nm

X32L

**PX32L...** Basic gearbox  
*Riduttore base*

M. flanges	Kit code	øF	A
71B14	KI634047	105	182.5
80B14	KI634046	120	184.5
90B14	KI634041	140	184.5

**Gearbox weight** 12.0 kg  
*Peso riduttore*

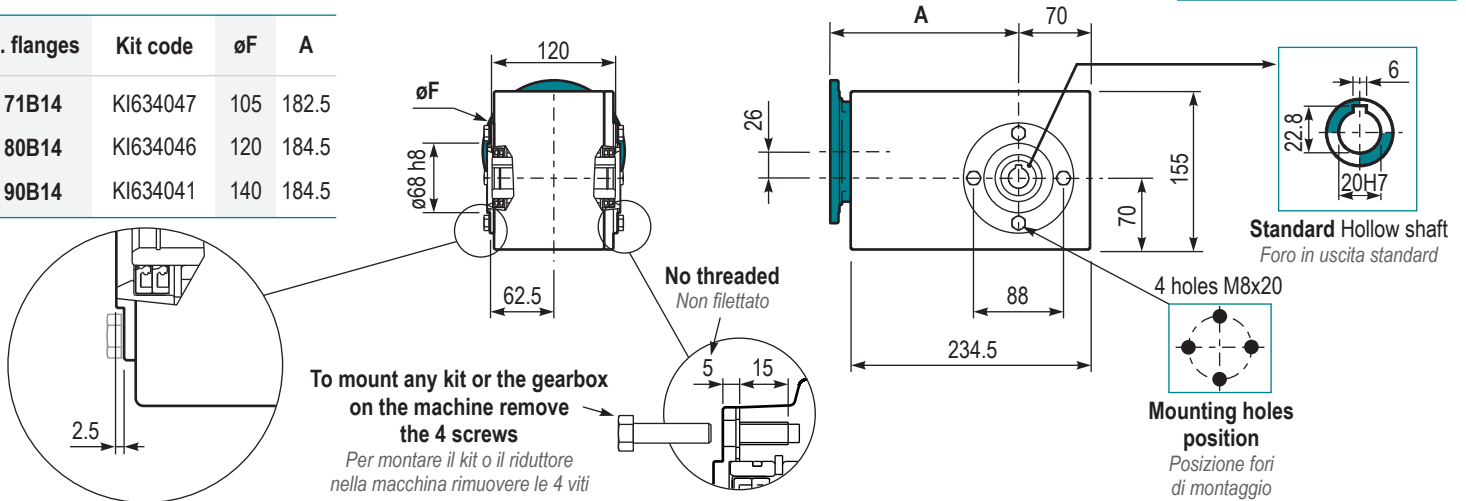

**PX32LPA..** Feet  
*Piedini*

**PX32LPV..** Feet  
*Piedini*

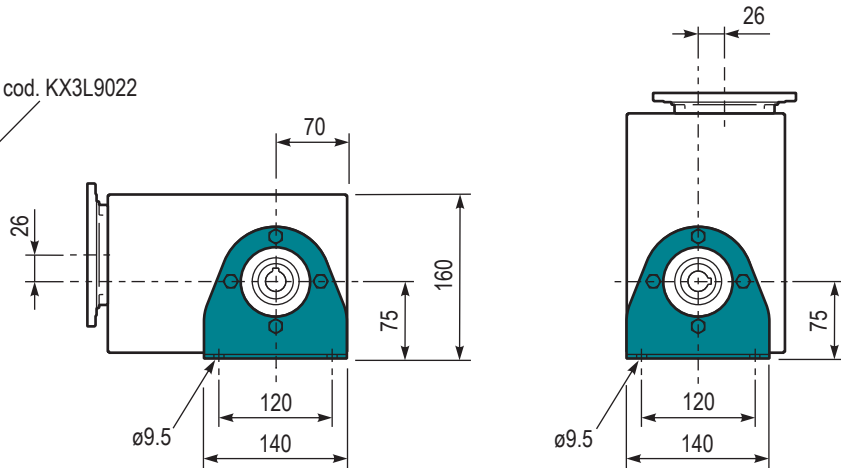
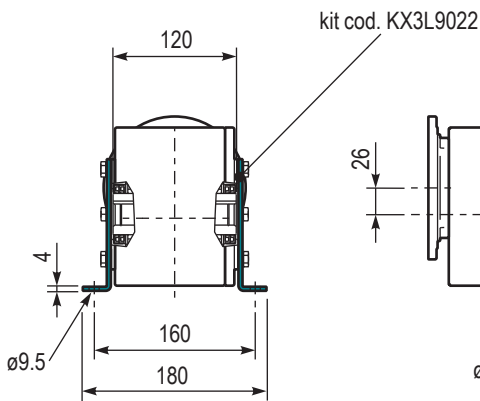

**PX32LA..** Single output shaft  
*Albero semplice in uscita*

**PX32LBR..** Reaction Arm  
*Braccio di reazione*

cod. X3L0209  
**Protection cap ( on request )**  
*A richiesta coperchio di protezione*

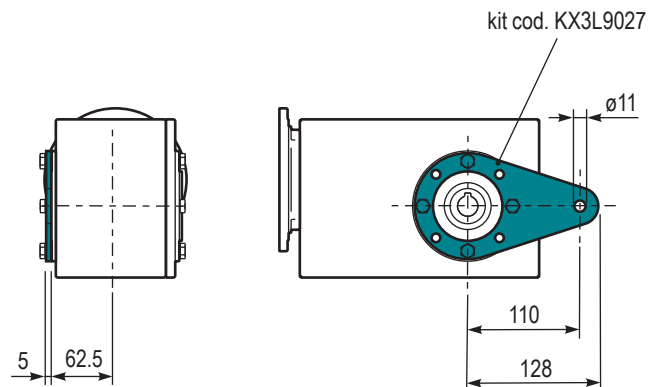
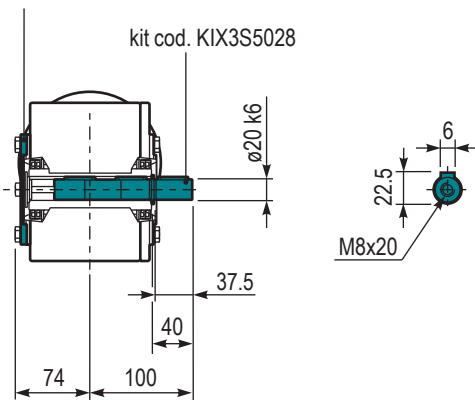

The dynamic efficiency is **0.96** for all ratios

Input speed ( $n_1$ ) = 1400 min<sup>-1</sup>

Output speed $n_2$ [min <sup>-1</sup> ]	Ratio $i$	Motor power $P_{1M}$ [kW]	Output torque $M_{2M}$ [Nm]	Service factor $f_s$	Nominal power $P_{1R}$ [kW]	Nominal torque $M_{2R}$ [Nm]	B5 motor flanges		B14 motor flanges			Output shaft 	Ratio code
							-	-	-Q 71	-R 80	-T 90		
192	<b>7.29</b>	1.5	71	1.3	<b>2.0</b>	<b>95</b>			C	C		2811	01
125	<b>11.20</b>	1.5	110	1.4	<b>2.0</b>	<b>150</b>			C	C		288	02
106	<b>13.18</b>	1.5	129	1.2	<b>1.7</b>	<b>150</b>			C	C		1911	03
92	<b>15.27</b>	1.1	109	1.4	<b>1.5</b>	<b>150</b>			C	C		1711	04
78	<b>17.93</b>	1.1	128	1.2	<b>1.3</b>	<b>150</b>			C	C		1511	05
69	<b>20.25</b>	1.1	145	1.0	<b>1.1</b>	<b>150</b>			C	C		198	06
65	<b>21.40</b>	1.1	153	1.0	<b>1.1</b>	<b>150</b>			C	C		1311	07
60	<b>23.47</b>	0.75	115	1.3	<b>0.98</b>	<b>150</b>			C	C		178	08
51	<b>27.55</b>	0.75	135	1.1	<b>0.83</b>	<b>150</b>			C	C		158	09
47.9	<b>29.21</b>	0.75	143	1.0	<b>0.78</b>	<b>150</b>			C	C		1011	10
42.6	<b>32.88</b>	0.75	161	0.9	<b>0.70</b>	<b>150</b>			C	C		138	11
36.7	<b>38.12</b>	0.55	138	1.1	<b>0.60</b>	<b>150</b>			C	C		911	12
31.2	<b>44.89</b>	0.55	163	0.9	<b>0.51</b>	<b>150</b>			C	C		108	13
27.8	<b>50.34</b>	0.37	122	1.1	<b>0.40</b>	<b>131</b>			C	C		711	14
23.9	<b>58.58</b>	0.37	142	1.1	<b>0.39</b>	<b>150</b>			C	C		98	15
18.1	<b>77.36</b>	0.25	126	1.2	<b>0.30</b>	<b>150</b>			C	C		78	16

Motor flanges available  
Flange motore disponibili

 B) Supplied with reduction bushing  
Fornito con bussola di riduzione

B) Available on request without reduction bushing  
Disponibile a richiesta senza bussola di riduzione

 C) Motor flange holes position  
Posizione fori flangia motore

## Lubrication

Lubrificazione

Always specify the mounting position  
Specificare sempre la posizione di montaggio

Unit X42L is supplied with synthetic oil to assure long life lubrication.  
Food grade oil is available on request.  
See Table 1 for lubrication and recommended quantity.

See Table 2 for possible radial and axial loads on the gearbox.

Il riduttore tipo X42L viene fornito con olio sintetico e lubrificazione tipo "long life".  
Disponibile a richiesta olio alimentare.

Vedi Tabella 1 per oli e quantità consigliati.

Vedi Tabella 2 per i carichi radiali e assiali applicabili al riduttore.

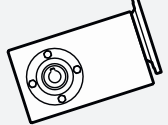
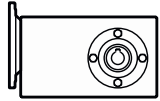
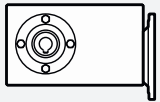
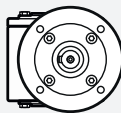
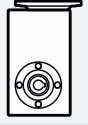
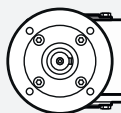
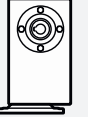
<b>Agip</b> Telium VSF 320	<b>Shell</b> Omala S4 WE 320	<b>V8</b> On request ASK	
<b>B3</b> Standard 0.60 LT		<b>B8</b> On request 0.70 LT	
<b>B6</b> On request 0.75 LT		<b>V5</b> On request 1.10 LT	
<b>B7</b> On request 0.50 LT		<b>V6</b> On request 0.60 LT	

Tab. 1

## Radial and axial loads

Carichi radiali e assiali

### Output shaft

Albero di uscita

$n_2$ [min <sup>-1</sup> ]	$F_A$ [N]	$F_R$ [N]
250	500	2500
150	600	3000
100	700	3500
75	800	4000
50	960	4800
25	960	4800
15	960	4800

$$F_{eq} = F_R \cdot \frac{54}{X + 28}$$

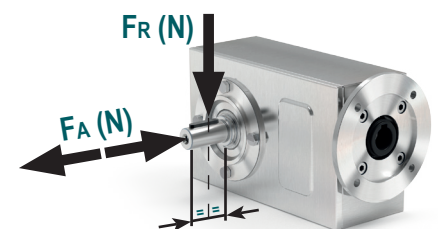
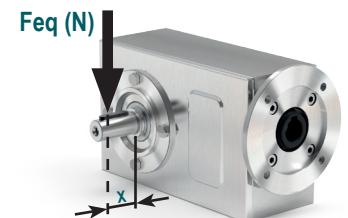

Tab. 2

150  
Nm

X42L

**P**X42L... **Basic gearbox**  
*Riduttore base*

**Gearbox weight** 10.5 kg  
*Peso riduttore*

M. flanges	Kit code	øF	A
71B14	KI634047	105	198
80B14	KI634046	120	200
90B14	KI634041	140	200

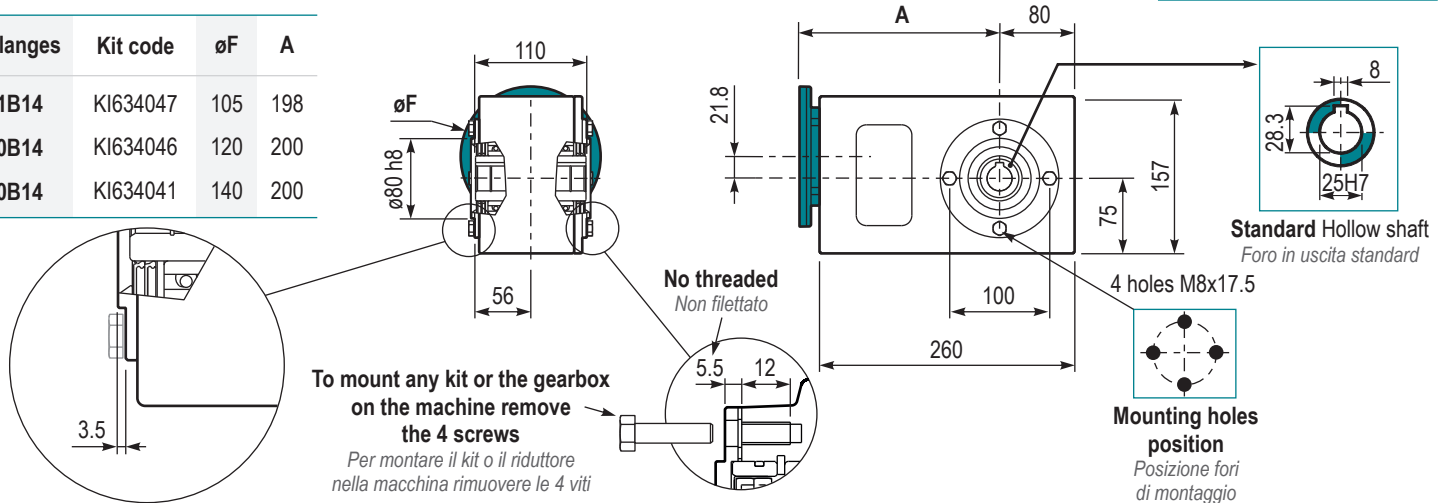

PX42L **PA..** **Feet**  
*Piedini*

PX42L **PV..** **Feet**  
*Piedini*

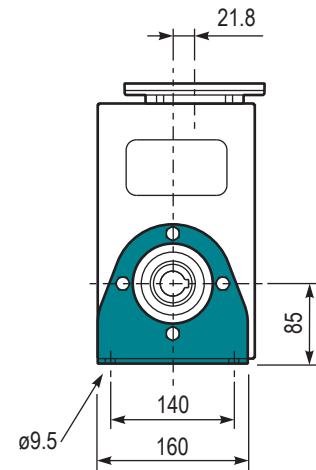
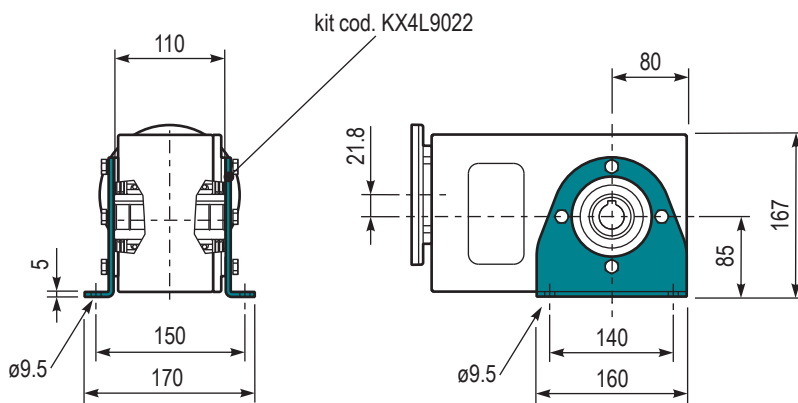

PX42L **A..** **Single output shaft**  
*Albero semplice in uscita*

PX42L **BR..** **Reaction Arm**  
*Braccio di reazione*

cod. X4L0209  
**Protection cap ( on request )**  
*A richiesta coperchio di protezione*

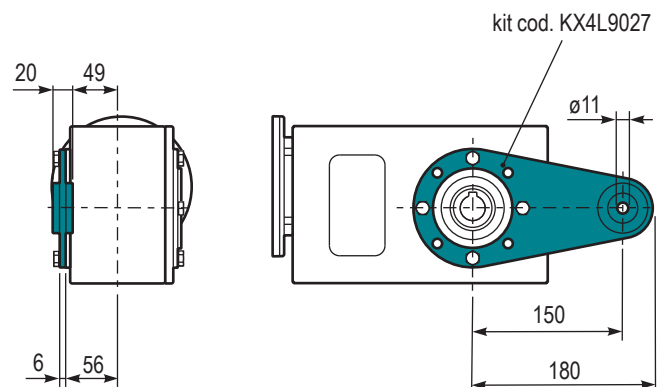
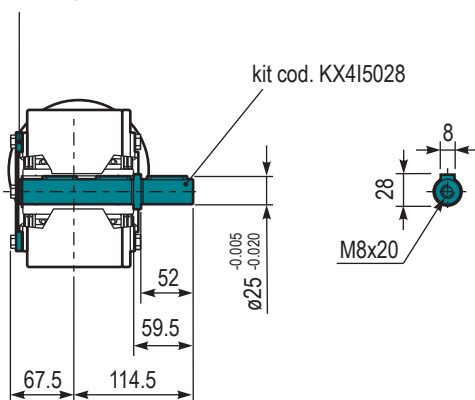

# X52L

## 250 Nm

### BVL series

# Stainless steel shielded helical bevel gearboxes

Riduttori a coppia conica schermati in acciaio inox

The dynamic efficiency is **0.96** for all ratios

Input speed ( $n_1$ ) = 1400 min<sup>-1</sup>

Output speed $n_2$ [min <sup>-1</sup> ]	Ratio $i$	Motor power $P_{1M}$ [kW]	Output torque $M_{2M}$ [Nm]	Service factor $f_s$	Nominal power $P_{1R}$ [kW]	Nominal torque $M_{2R}$ [Nm]	B5 motor flanges				B14 motor flanges			Output shaft 	Ratio code
							-	-	-	-	-R	-T	-U		
232	6.03	3	116	1.2	3.4	135								3011	01
151	9.26	3	179	0.9	2.6	155								308	02
123	11.36	3	219	1.0	3.1	230								2011	03
91	15.36	2.2	218	1.1	2.5	250								1611	04
80	17.46	2.2	248	1.0	2.2	250								208	05
70	19.97	2.2	284	0.9	1.9	250								1311	06
59	23.60	1.5	231	1.1	1.6	250								168	07
57	24.45	1.5	239	1.0	1.6	250								1111	08
45.6	30.69	1.1	220	1.1	1.2	250								138	09
39.6	35.35	1.1	253	1.0	1.1	250								811	10
37.3	37.57	1.1	269	0.9	1.0	250								118	11
28.8	48.68	0.75	239	1.0	0.78	250								611	12
25.8	54.33	0.75	267	0.9	0.70	250								88	13
18.7	74.81	0.55	271	0.8	0.43	210								68	14

Motor flanges available  
Flange motore disponibili

 B) Supplied with reduction bushing  
Fornito con Bussola di Riduzione

B) Available on request without reduction bushing  
Disponibile a Richiesta senza Bussola di Riduzione

 C) Motor flange holes position  
Posizione Fori Flangia Motore

## Lubrication

Lubrificazione

Always specify the mounting position

Specificare sempre la posizione di montaggio

Unit X52L is supplied with synthetic oil to assure long life lubrication.  
Food grade oil is available on request.

See Table 1 for lubrication and recommended quantity.



See Table 2 for possible radial and axial loads on the gearbox.

Il riduttore tipo X52L viene fornito con olio sintetico e lubrificazione tipo "long life".

Disponibile a richiesta olio alimentare.

Vedi Tabella 1 per oli e quantità consigliati.

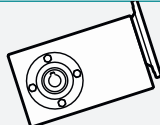
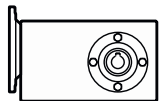
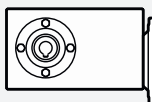
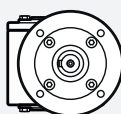
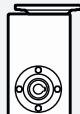
Vedi Tabella 2 per i carichi radiali e assiali applicabili al riduttore.

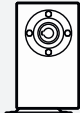
<b>Agip</b> Telium VSF 320	<b>Shell</b> Omala S4 WE 320	<b>V8</b> On request ASK	
<b>B3</b> Standard 0.90 LT		<b>B8</b> On request 1.40 LT	
<b>B6</b> On request 1.50 LT		<b>V5</b> On request 1.95 LT	
<b>B7</b> On request 0.75 LT		<b>V6</b> On request 1.15 LT	

Tab. 1

## Radial and axial loads

Carichi radiali e assiali

### Output shaft

Albero di uscita

$n_2$ [min <sup>-1</sup> ]	$F_A$ [N]	$F_R$ [N]
250	600	3000
150	700	3500
100	800	4000
75	820	4100
50	960	4800
25	1350	6750
15	1660	8300

$$F_{eq} = F_R \cdot \frac{61.5}{X + 31}$$

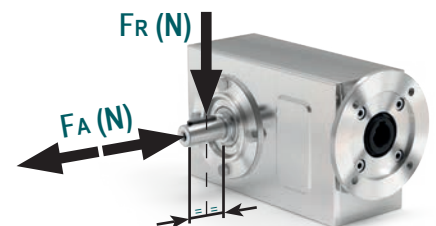
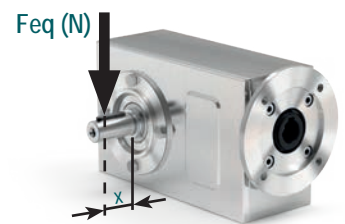

Tab. 2



250  
Nm

X52L

PX52L...

Basic gearbox  
Riduttore base

Gearbox weight  
Peso riduttore 15.8 kg

M. flanges	Kit code	øF	A
80 B14	KI854046	120	236.5
90 B14	KI854045	140	236.5
100-112 B14	KI854041	160	245.5

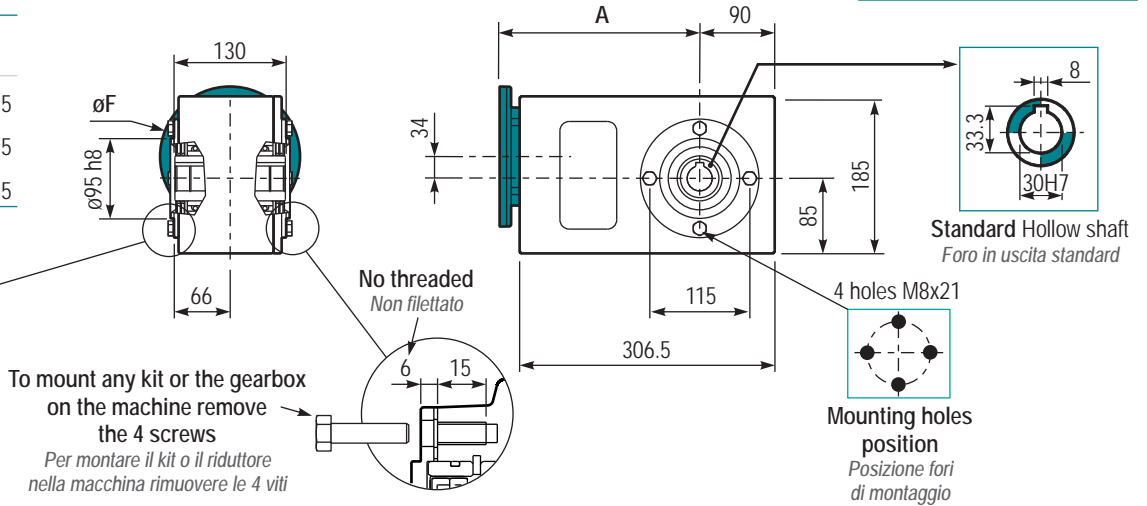
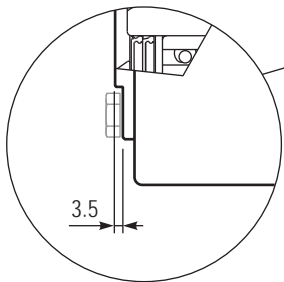

PX52L PA..

Feet  
Piedini

PX52L PV..

Feet  
Piedini

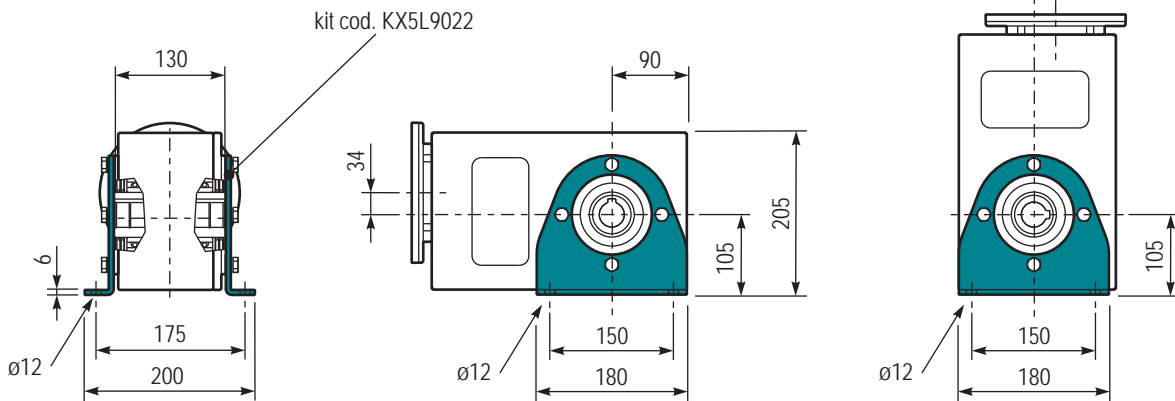

PX52L A..

Single output shaft  
Albero semplice in uscita

cod. X5L0209

Protection cap (on request)

A richiesta coperchio di protezione

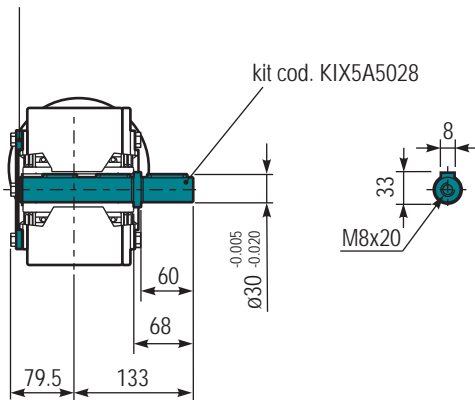

PX52L BR..

Reaction Arm  
Braccio di reazione

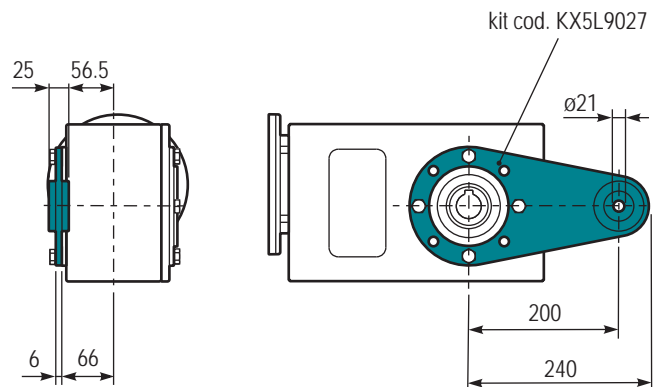

# X62L

## 410 Nm

### BVL series

# Stainless steel shielded helical bevel gearboxes

Riduttori a coppia conica schermati in acciaio inox

The dynamic efficiency is **0.96** for all ratios

Input speed ( $n_1$ ) = 1400 min<sup>-1</sup>

Output speed $n_2$ [min <sup>-1</sup> ]	Ratio $i$	Motor power $P_{1M}$ [kW]	Output torque $M_{2M}$ [Nm]	Service factor $f_s$	Nominal power $P_{1R}$ [kW]	Nominal torque $M_{2R}$ [Nm]	B5 motor flanges				B14 motor flanges			Output shaft 	Ratio code
							-	-	-	-	-R	-T	-U		
232	6.03	4	155	1.6	6.1	240	-	-	-	-	-R	-T	-U	3011	01
151	9.26	4	238	1.1	4.5	270	-	-	-	-	80	90	100-112	308	02
123	11.36	4	291	1.2	4.7	350	-	-	-	-	-	-	-	2011	03
91	15.36	4	394	1.0	3.8	385	-	-	-	-	-	-	-	1611	04
80	17.46	4	448	0.9	3.5	400	-	-	-	-	-	-	-	208	05
70	19.97	3	386	1.1	3.1	410	-	-	-	-	-	-	-	1311	06
59	23.60	3	456	0.9	2.7	410	-	-	-	-	-	-	-	168	07
57	24.45	3	472	0.9	2.6	410	-	-	-	-	-	-	-	1111	08
45.6	30.69	2.2	436	0.9	2.0	410	-	-	-	-	-	-	-	138	09
39.6	35.35	1.5	346	1.2	1.8	410	-	-	-	-	-	-	-	811	10
37.3	37.57	1.5	368	1.1	1.7	410	-	-	-	-	-	-	-	118	11
28.8	48.68	1.1	348	1.0	1.1	365	-	-	-	-	-	-	-	611	12
25.8	54.33	1.1	389	1.1	1.2	410	-	-	-	-	-	-	-	88	13
18.7	74.81	0.75	367	1.0	0.73	360	-	-	-	-	-	-	-	68	14

Motor flanges available  
Flange motore disponibili

 B) Supplied with reduction bushing  
Fornito con Bussola di Riduzione

B) Available on request without reduction bushing  
Disponibile a Richiesta senza Bussola di Riduzione

 C) Motor flange holes position  
Posizione Fori Flangia Motore

## Lubrication

Lubrificazione

Always specify the mounting position

Specificare sempre la posizione di montaggio

Unit X62L is supplied with synthetic oil to assure long life lubrication.  
Food grade oil is available on request.

See Table 1 for lubrication and recommended quantity.

See Table 2 for possible radial and axial loads on the gearbox.

Il riduttore tipo X62L viene fornito con olio sintetico e lubrificazione tipo "long life".

Disponibile a richiesta olio alimentare.

Vedi Tabella 1 per oli e quantità consigliati.

Vedi Tabella 2 per i carichi radiali e assiali applicabili al riduttore.

**Agip**

Telium VSF 320

**Shell**

Omala S4 WE 320

**V8**

On request

ASK

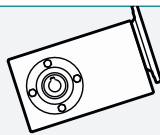

**B3**

Standard

1.25 LT

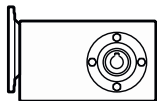

**B8**

On request

1.60 LT

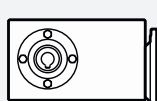

**B6**

On request

1.70 LT

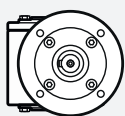

**V5**

On request

2.45 LT

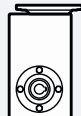

**B7**

On request

0.95 LT

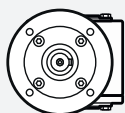

**V6**

On request

1.50 LT

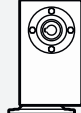

## Radial and axial loads

Carichi radiali e assiali

### Output shaft

Albero di uscita

$n_2$ [min <sup>-1</sup> ]	$F_A$ [N]	$F_R$ [N]
250	600	3000
150	700	3500
100	780	3900
75	890	4450
50	1140	5700
25	1330	6650
15	1660	8300

$$F_{eq} = F_R \cdot \frac{69}{X + 39}$$

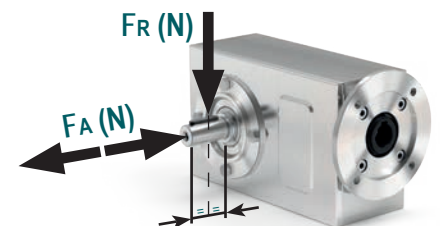
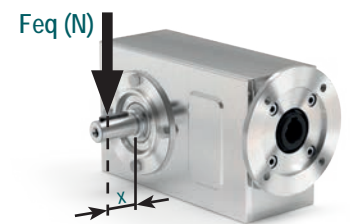

Tab. 1

Tab. 2

410  
Nm

X62L

**P**X62L... Basic gearbox  
*Riduttore base*

**Gearbox weight** 19.5 kg  
*Peso riduttore*

M. flanges	Kit code	øF	A
80 B14	KI854046	120	255.5
90 B14	KI854045	140	255.5
100-112 B14	KI854041	160	264.5

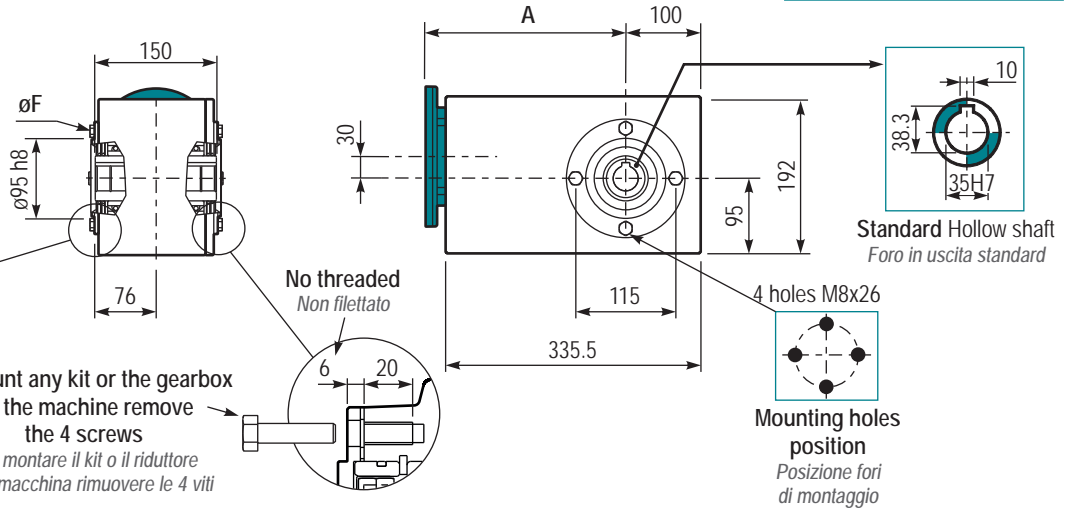
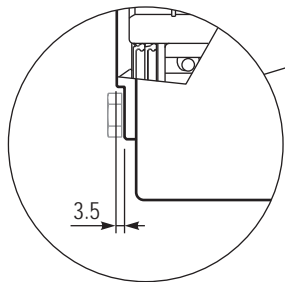

**PX62LPA..** Feet  
*Piedini*

**PX62LPV..** Feet  
*Piedini*

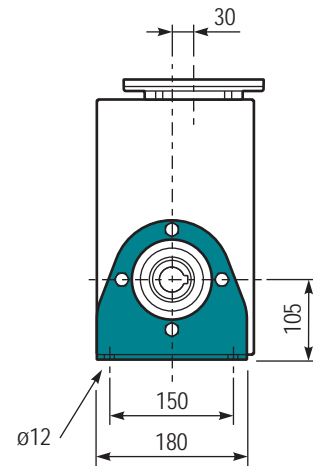
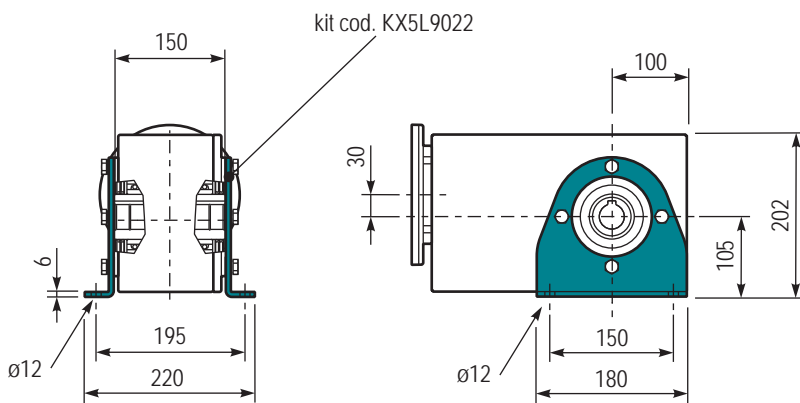

**PX62LA..** Single output shaft  
*Albero semplice in uscita*

**PX62LBR..** Reaction Arm  
*Braccio di reazione*

cod. X5L0209  
Protection cap (on request)  
*A richiesta coperchio di protezione*

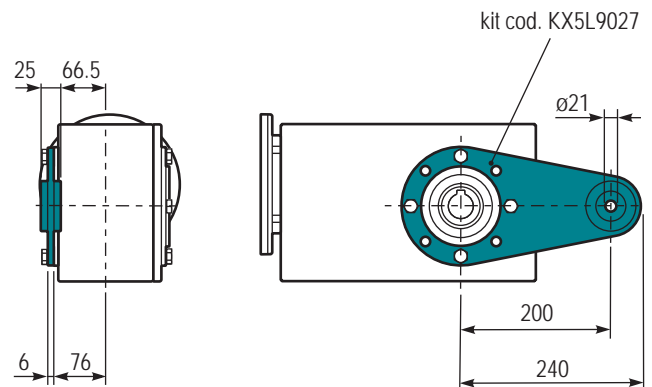
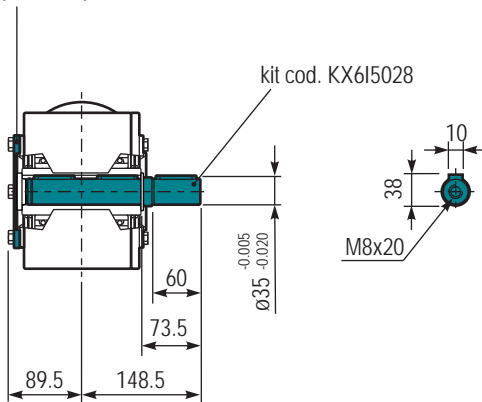



# I VFI series Full stainless steel worm gearboxes

*Riduttori a vite senza fine completamente in acciaio inox*

Section **7**  
Sezione 7

This range is



certified

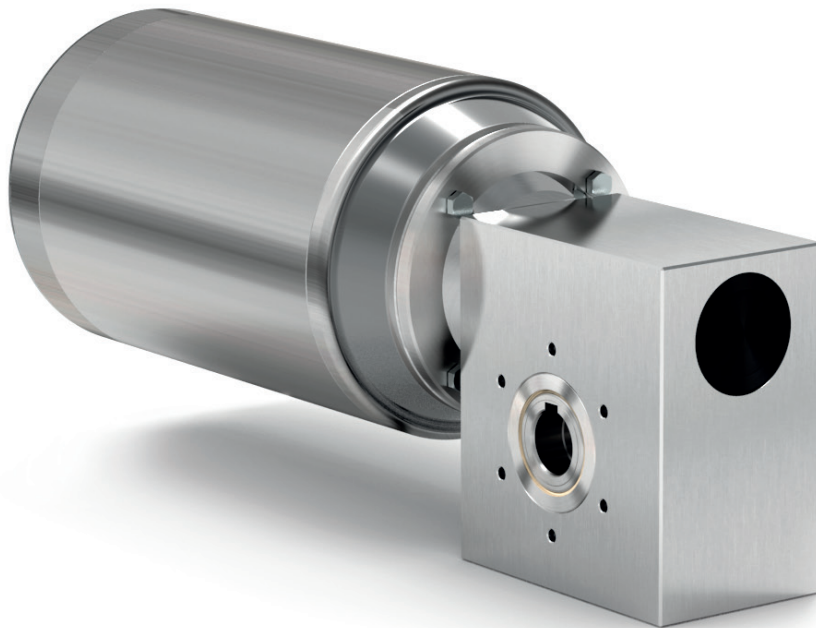

# FEATURES

Caratteristiche

## VFI series Full stainless steel worm gearboxes

Riduttori a vite senza fine completamente in acciaio inox

Type <i>Tipo</i>	Torque <i>Coppia</i>	Center distance <i>Interasse</i>	Input power <i>Potenza in entrata</i>	Hollow output shaft <i>Albero cavo in uscita</i>
I30	21 Nm	30 mm	0.06 ÷ 0.18 kW	ø14 mm
I45	41 Nm	45 mm	0.12 ÷ 0.37 kW	ø18 mm ø19 mm
I50	72 Nm	50 mm	0.12 ÷ 0.75 kW	ø25 mm ø24 mm
I63	147 Nm	63 mm	0.37 ÷ 1.8 kW	ø25 mm ø28 mm
I85	347 Nm	85 mm	0.55 ÷ 4.0 kW	ø35 mm
I11	651 Nm	110 mm	1.1 ÷ 4.0 kW	ø42 mm

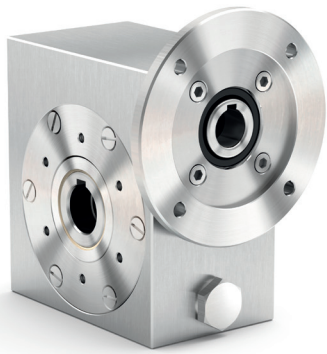

This product is:

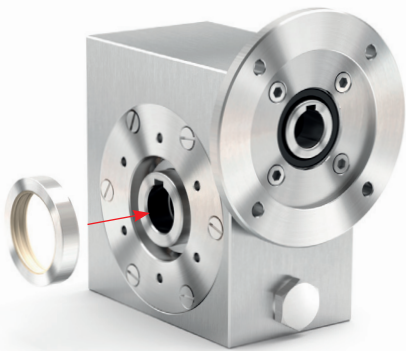

Twin viton seals with stainless steel 316L shield.



Doppio anello di tenuta in viton con schermo protettivo in acciaio inox AISI 316L.

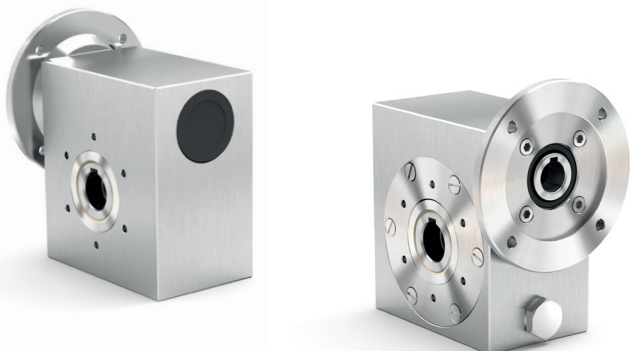

Mounting holes on both sides of the housing for versatile mounting.

Fori di montaggio in entrambi i lati della cassa.

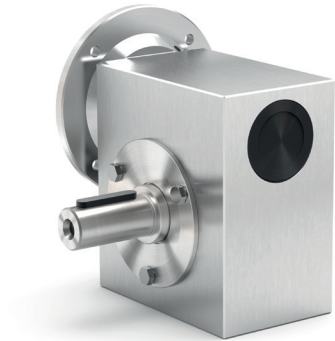

**Output shaft is produced in AISI 316L.  
Special cover assures full protection of oil seals.**

*Albero in uscita in AISI 316L e coperchietto protettivo per anelli di tenuta.*



**Closed protection cap in AISI 316L with o-ring.**

*Coperchietto di protezione chiuso in AISI 316L con o-ring.*



**CuSn12Ni (C91700) Nickel bronze worm gears are centrifugally cast onto an iron hub for maximum strength and superior life. Removable hollow shaft with key for safe torque transmissions.**

*Corona in bronzo al Nickel CuSn12Ni (C91700) centrifugato e mozzo in acciaio inox per massima resistenza e durata superiore. Albero cavo removibile con chiavetta mozzo/corona.*

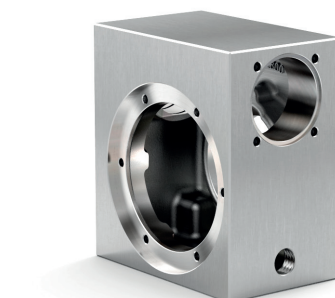





**Special high tech full stainless steel housing with accurate finishing and strong rigidity.**



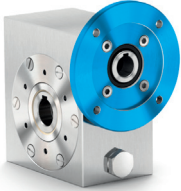
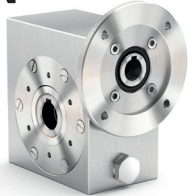
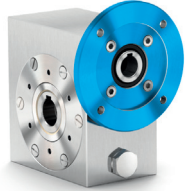

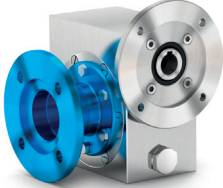
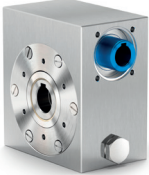
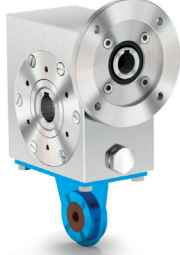



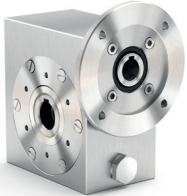
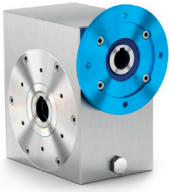

*Finitura speciale su una cassa inox che presenta un'alta rigidità strutturale.*

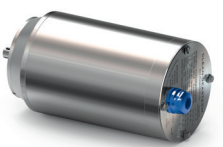
# How to order

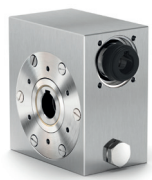
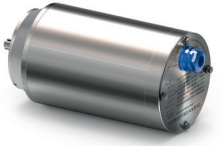
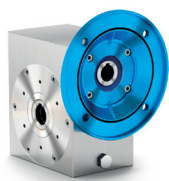
Codifica

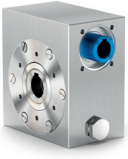
<b>P</b>	<b>I50</b>	<b>UN</b>	<b>10</b>	<b>I</b>
Type <i>Tipo</i>	Size <i>Grandezza</i>	Mounting <i>Montaggio</i>	Ratio <i>Rapporto</i>	Hub <i>Mozzo corona</i>
<b>P</b> 	<b>I30</b> <b>I45</b> <b>I50</b> <b>I63</b> <b>I85</b> <b>I11</b>	<b>UN</b> 	See technical data table <i>Vedi tabelle dati tecnici</i>	<b>I</b> 
<b>M</b> 		<b>FL</b> 		<b>Standard</b> <i>I30 -&gt; ø14</i> <i>I45 -&gt; ø18</i> <i>I50 -&gt; ø25</i> <i>I63 -&gt; ø25</i> <i>I85 -&gt; ø35</i> <i>I11 -&gt; ø42</i>
<b>B</b> 		<b>BR</b> 		<b>Z</b> <b>Inch</b> <i>I45 -&gt; ø0.750"</i> <i>I50 -&gt; ø1.000"</i> <i>I63 -&gt; ø1.250"</i> <i>I85 -&gt; ø1.500"</i> <i>I11 -&gt; ø2.000"</i>
<b>R</b> 				

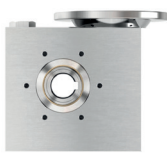
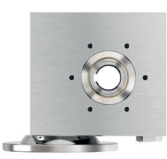

<b>S</b>	<b>-R</b>	<b>B3</b>	<b>-</b>	With Type M specify terminal box position <i>Con tipo M specificare posizione morsetti</i>
Output shaft <i>Albero lento</i>	Motor size <i>Grandezza motore</i>	Mounting position <i>Posizione di montaggio</i>	Input bore <i>Foro entrata</i>	Terminal box position <i>Posizione morsetti</i>
<p><b>Ø</b></p> 	<p><b>Flange</b> <i>Flange</i></p> 	<p><b>B3</b></p> 	<p><b>-</b> Standard bore <i>Foro standard</i></p> <p><b>P</b> Input bore reduced one size <i>Foro entrata ridotto di una entrata</i></p>	<p><b>A</b></p> 
<p><b>S</b></p> 	<p><b>IEC B14</b></p> <ul style="list-style-type: none"> <li>-P -&gt; 63B14 (ø90)</li> <li>-Q -&gt; 71 B14 (ø105)</li> <li>-R -&gt; 80 B14 (ø120)</li> <li>-T -&gt; 90 B14 (ø140)</li> <li>-U -&gt; 100-112B14 (ø160)</li> </ul>	<p><b>B8</b></p> 	<p><b>Q</b> Input bore reduced two size <i>Foro entrata ridotto di due misure</i></p> <p><b>With coupling</b> <i>Con giunto</i></p> 	<p><b>B</b></p> 
<p><b>NEMA</b></p>  <ul style="list-style-type: none"> <li>-W -&gt; 56C (ø6.5")</li> <li>-X -&gt; 143/5TC (ø6.5")</li> <li>-Y -&gt; 182/4TC (ø8.88")</li> <li><b>AA</b> -&gt; 213/5TC (ø8.88")</li> </ul>		<p><b>B6</b></p> 	<p><b>B</b> -&gt; 11mm</p> <p><b>C</b> -&gt; 14mm</p> <p><b>D</b> -&gt; 19mm</p> <p><b>E</b> -&gt; 24mm</p> <p><b>F</b> -&gt; 28mm</p> <p><b>W</b> -&gt; ø0.625"</p> <p><b>X</b> -&gt; ø0.875"</p> <p><b>Y</b> -&gt; ø1.125"</p>	<p><b>C</b></p> 
<p><b>Without flange</b> <i>Senza flangia</i></p>  <ul style="list-style-type: none"> <li>-M -&gt; Metric</li> <li>-N -&gt; Nema</li> </ul>		<p><b>B7</b></p> 	<p><b>0</b> Ready for input coupling <i>Predisposto per giunto</i></p> 	<p><b>D</b></p> 
<p><b>Type R</b> <i>Tipo R</i></p>  <ul style="list-style-type: none"> <li>-O -&gt; Metric</li> </ul>		<p><b>V5</b></p>  <p><b>V6</b></p> 		

# Useful formulas

Formule utili

## Required power - Potenza richiesta

Lifting - Sollevamento

Rotation - Rotazione

Linear movement - Traslazione

$$P_{[kW]} = \frac{M_{[Kg]} \cdot g_{[9.81]} \cdot v_{[m/s]}}{1000}$$

$$P_{[kW]} = \frac{M_{[Nm]} \cdot n_{[rpm]}}{9550}$$

$$P_{[kW]} = \frac{F_{[N]} \cdot v_{[m/s]}}{1000}$$

## Torque - Coppia

$$M_{[Nm]} = \frac{9550 \cdot P_{[kW]}}{n_{[rpm]}}$$

$$M_{[lb\ in]} = \frac{63030 \cdot P_{[HP]}}{n_{[rpm]}}$$

## Radial loads - Carichi radiali

Radial load generated by external transmissions keyed onto input and/or output shafts.

Forza radiale generata da organi di trasmissione calettati sugli alberi di ingresso e/o uscita.

$$F_{R[N]} = \frac{M_{[Nm]} \cdot 2000}{d_{[mm]}} \cdot f_k$$

$$F_{R[N]} = \frac{M_{[lb\ in]} \cdot 8.9}{d_{[in]}} \cdot f_k$$

**M:** Output torque - *Momento torcente*

**d:** Diam. of driving element - *Diametro primitivo*

**f<sub>k</sub>:** Factor - *Coefficiente di trasformazione*

1.15: Gearwheels - *Ingranaggi*

1.25: Chain sprockets - *Catena*

1.75: Narrow v-belt pulley - *Cinghia Trapezoidale*

2.50: Flat-belt pulley - *Cinghia piatta*

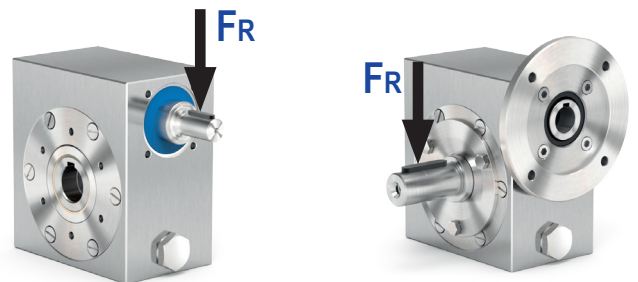

If your application requires higher radial loads, contact our technical office. Higher loads may be possible.

Nel caso la vostra applicazione richieda carichi radiali superiori consultare il nostro ufficio tecnico, valori maggiori possono essere accettati.

# How to select a gearbox

Come selezionare un riduttore

- A** Select required torque (according to service factor)  
*Seleziona la coppia desiderata (comprensiva del fattore di servizio)*
- B** Select output speed  
*Seleziona la velocità in uscita*
- C** Select gear ratio in the line corresponding to the chosen motor power  
*Sulla riga corrispondente alla motorizzazione prescelta si può rilevare il rapporto di riduzione*
- D** Select motor flange available (if requested)  
*Scegli la flangia disponibile (se richiesta)*

Gear size <i>Grandezza riduttore</i>	<b>C</b>	Ratio <i>Rapporto</i>	Transmitted torque <i>Momento torcente trasmesso</i>	Nominal power <i>Potenza nominale</i>	Flange code <i>Codice flangia</i>	Dynamic efficiency <i>Rendimento dinamico</i>	Input speed <i>Velocità in entrata</i>
---	----------	--------------------------	---	--	--------------------------------------	--	---

**130**

**21 Nm**

## VFI series Full stainless steel worm gearboxes

*Riduttori a vite senza fine completamente in acciaio inox*

Input speed (n<sub>1</sub>) = 1400 min<sup>-1</sup>

Output speed n <sub>2</sub> [min <sup>-1</sup> ]	Ratio i	Motor power P <sub>1M</sub> [kW]	Output torque M <sub>2M</sub> [Nm]	Service factor f.s	Nominal power P <sub>1R</sub> [kW]	Nominal torque M <sub>2R</sub> [Nm]	B5 motor flanges		B14 motor flanges		Dynamic efficiency RD	Tooth module [mm]	Ratios code
							-	-	-O 56	-P 63			
280	5	0.18	5	3.3	0.60	17			B-C		82	1.26	01
200	7	0.18	7	2.4	0.44	17			B-C		80	1.44	02
140	10	0.18	10	1.8	0.32	17			B-C		78	1.44	03
93	15	0.18	13	1.4	0.25	19			B-C		73	1.44	04
70	20	0.18	17	1.1	0.20	19			B-C		70	1.09	05
47	30	0.12	15	1.4	0.17	21			B-C		62	1.44	06
35	40	0.12	19	1.1	0.13	20			B-C		57	1.09	07
23	61	0.09	19	1.1	0.10	20			B-C		50	0.72	08
17.5	80	0.06	16	1.0	0.06	16			B-C		48	0.56	09
14	100	0.06*	16	0.5	0.03	8			B-C		40	0.45	10

<b>B</b> Output speed <i>Velocità in uscita</i>	Motor power <i>Potenza motore</i>	Service factor <i>Fattore di servizio</i>	<b>A</b> Nominal torque <i>Momento torcente nominale</i>	Nominal module <i>Modulo nominale</i>	Notes <i>Note</i>
--	--------------------------------------	--	---	--	----------------------

### Type of load and starts per hour *Tipo di carico e avviamenti per ora*

	Type of load	Oper. hours per day <i>Ore di funz. giorn.</i>		
		<2h	2÷8h	8÷16h
Continuous or intermittent application with start / hour <i>Applicazione continua o intermittente con numero operazioni/ora</i>	Uniform - <i>Uniforme</i>	0.9	1	1.25
	Moderate - <i>Moderato</i>	1	1.25	1.5
	Heavy - <i>Forte</i>	1.25	1.5	1.75
Intermittent application with start / hour <i>Applicazione intermittente con numero operazioni/ora</i>	Uniform - <i>Uniforme</i>	1.25	1.5	1.75
	Moderate - <i>Moderato</i>	1.5	1.75	2
	Heavy - <i>Forte</i>	1.75	2	2.25

**D** Motor flange available  
*Flange disponibili*

**B)** Mounting with reduction bushing  
*Montaggio con boccia di riduzione*

**C)** Motor flange holes position/terminal box position  
*Posizione fori flangia/basetta motore*

**B)** Available without reduction bushing  
*Disponibile anche senza boccia*



# I30

# 21 Nm

## VFI series Full stainless steel worm gearboxes

Riduttori a vite senza fine completamente in acciaio inox

Input speed ( $n_1$ ) = 1400 min<sup>-1</sup>

Output speed	Ratio	Motor power	Output torque	Service factor	Nominal power	Nominal torque	B5 motor flanges		B14 motor flanges		Dynamic efficiency	Tooth module	Ratios code
$n_2$ [min <sup>-1</sup> ]	$i$	$P_{1M}$ [kW]	$M_{2M}$ [Nm]	f.s	$P_{1R}$ [kW]	$M_{2R}$ [Nm]	-	-	-O	-P	RD		
							-	-	56	63		[mm]	
280	5	0.18	5	3.3	0.60	17			B-C		82	1.26	01
200	7	0.18	7	2.4	0.44	17			B-C		80	1.44	02
140	10	0.18	10	1.8	0.32	17			B-C		78	1.44	03
93	15	0.18	13	1.4	0.25	19			B-C		73	1.44	04
70	20	0.18	17	1.1	0.20	19			B-C		70	1.09	05
47	30	0.12	15	1.4	0.17	21			B-C		62	1.44	06
35	40	0.12	19	1.1	0.13	20			B-C		57	1.09	07
23	61	0.09	19	1.1	0.10	20			B-C		50	0.72	08
17.5	80	0.06	16	1.0	0.06	16			B-C		48	0.56	09
14	100	0.06*	16	0.5	0.03	8			B-C		40	0.45	10

\* Power higher than the maximum one which can be supported by the gearbox. Select according to the torque  $M_{2R}$

Potenza superiore a quella massima sopportabile dal riduttore. Selezionare in base al momento torcente  $M_{2R}$

**Motor flanges available**  
Flange motore disponibili

**B) Supplied with reduction bushing**  
Fornito con bussola di riduzione

**B) Available on request without reduction bushing**  
Disponibile a richiesta senza bussola di riduzione

**C) Motor flange holes position**  
Posizione fori flangia motore

### Lubrication

Lubrificazione

Unit I30 is supplied with synthetic oil to assure long life lubrication.

Food grade oil is available on request.

See Table 1 for lubrication and recommended quantity.

See Table 2 for possible radial and axial loads on the gearbox.

Il riduttore tipo I30 viene fornito con olio sintetico e lubrificazione tipo "long life".  
Disponibile a richiesta olio alimentare.

Vedi Tabella 1 per oli e quantità consigliati.

Vedi Tabella 2 per i carichi radiali e assiali applicabili al riduttore.

Vedi Tabella 2 per i carichi radiali e assiali applicabili al riduttore.

**Oil quantity for all positions: 0.06Lt.**

Quantità olio per tutte le posizioni: 0.06Lt

**Agip**  
Telium VSF 320

**Shell**  
Omala S4 WE 320

\* For more details on lubrication and plugs check our website.

\* Per maggiori dettagli su lubrificazione e tappi olio vedi il nostro sito web.

### Radial and axial loads

Carichi radiali e assiali

#### Output shaft

Albero di uscita

$n_2$ [min <sup>-1</sup> ]	$F_A$ [N]	$F_R$ [N]
200	120	600
150	140	700
100	160	800
75	180	900
50	200	1000
25	250	1250
15	280	1400

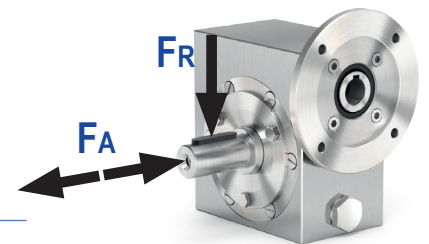

#### Input shaft

Albero in entrata

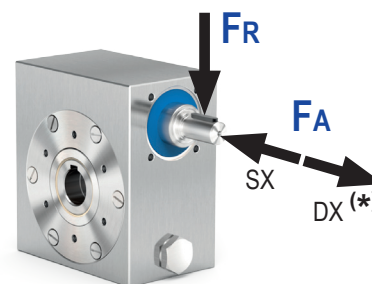

$n_1$ [min <sup>-1</sup> ]	$F_A$ [N]	$F_R$ [N]
1400	20	100

\* Strong axial loads in the DX direction are not allowed.

\* Non sono consentiti forti carichi assiali con direzione DX

Tab. 1

Tab. 2

PI30UN...

**Basic gearbox**  
Riduttore base

Gearbox weight  
peso riduttore **2.5 kg**

M. flanges	Kit code	øF	A
56B14	KI304046	80	61.5
63B14	KI304045	90	62.5

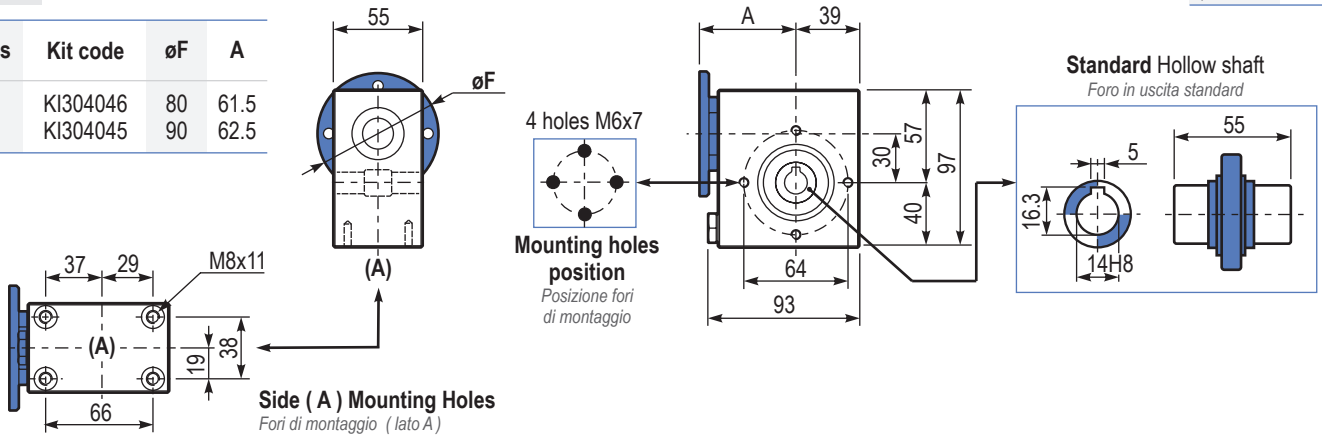

BI30UN...

**Modular base**  
Base modulare

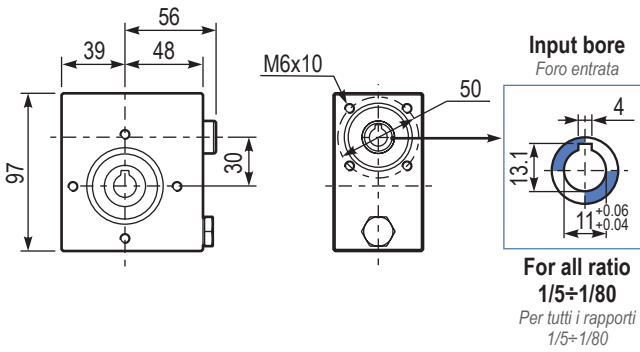

PI30FL...

**Output flange**  
Flangia uscita

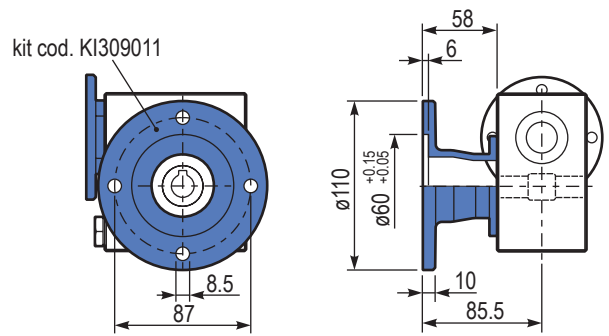

RI30UN...

**Input shaft**  
Albero in entrata

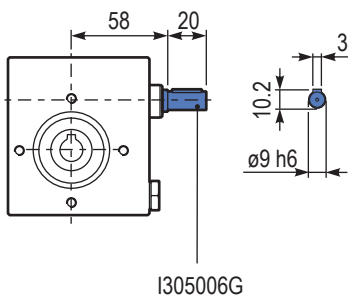

PI30BR...

**Reaction arm**  
Braccio di reazione

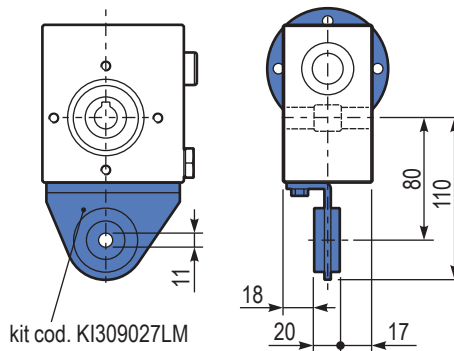

PI30.....S...

**Single Shaft**  
Albero lento semplice

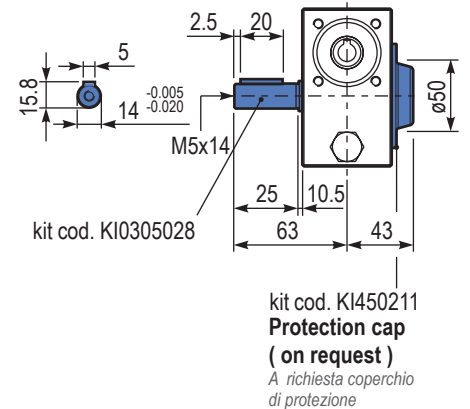

# I45

# 41 Nm

## VFI series Full stainless steel worm gearboxes

Riduttori a vite senza fine completamente in acciaio inox

Input speed ( $n_1$ ) = 1400 min<sup>-1</sup>

Output speed $n_2$ [min <sup>-1</sup> ]	Ratio $i$	Motor power $P_{1M}$ [kW]	Output torque $M_{2M}$ [Nm]	Service factor f.s	Nominal power $P_{1R}$ [kW]	Nominal torque $M_{2R}$ [Nm]	B5 motor flanges		B14 motor flanges		Dynamic efficiency RD	Tooth module [mm]	Ratios code
							-	-	-P 63	-Q 71			
200	7	0.37	14	2.2	0.80	30			B-C		80	2.2	01
140	10	0.37	20	1.5	0.57	30			B-C		79	2.2	02
100	14	0.37	27	1.1	0.41	30			B-C		77	2.4	03
67	21	0.37	36	1.2	0.43	41			B-C		67	1.6	04
50	28	0.25	31	1.3	0.33	41			B-C		65	2.5	05
38	37	0.25	40	1.0	0.26	41			B-C		63	1.8	06
30	46	0.25	46	0.9	0.22	41			B-C		59	1.5	07
23	60	0.18	41	1.0	0.18	41			B-C		56	1.2	08
20	70	0.12	31	1.0	0.12	30			B-C		54	1.0	09
13.7	102	0.12	41	0.7	0.09	29			B-C		49	0.72	10

Motor flanges available  
Flange motore disponibili



B) Supplied with reduction bushing  
Fornito con bussola di riduzione



B) Available on request without reduction bushing  
Disponibile a richiesta senza bussola di riduzione



C) Motor flange holes position  
Posizione fori flangia motore

### Lubrication

Lubrificazione

Unit I45 is supplied with synthetic oil to assure long life lubrication.  
Food grade oil is available on request.

See Table 1 for lubrication and recommended quantity.

See Table 2 for possible radial and axial loads on the gearbox.

Il riduttore tipo I45 viene fornito con olio sintetico e lubrificazione tipo "long life".

Disponibile a richiesta olio alimentare.

Vedi Tabella 1 per oli e quantità consigliati.

Vedi Tabella 2 per i carichi radiali e assiali applicabili al riduttore.

Agip

Telium VSF 320

Shell

Omala S4 WE 320

B3

Standard  
0.15 LT

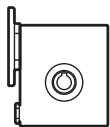

B8

On request  
0.15 LT

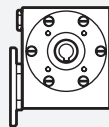

B6

On request  
0.15 LT

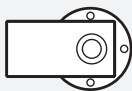

V5

On request  
0.15 LT

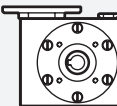

B7

On request  
0.20 LT

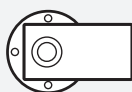

V6

On request  
0.15 LT

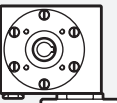

For more details on lubrication and plugs check our website.

Per maggiori dettagli su lubrificazione e tappi olio vedi il nostro sito web.

### Radial and axial loads

Carichi radiali e assiali

#### Output shaft

Albero di uscita

$n_2$ [min <sup>-1</sup> ]	$F_A$ [N]	$F_R$ [N]
200	180	900
150	200	1000
100	220	1100
75	240	1200
50	260	1400
25	300	1800
15	400	2000

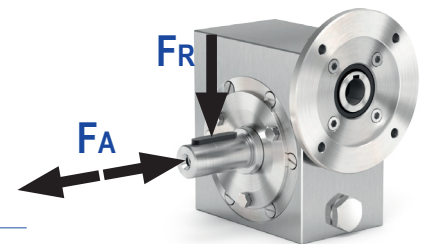

#### Input shaft

Albero in entrata

$n_1$ [min <sup>-1</sup> ]	$F_A$ [N]	$F_R$ [N]
1400	42	210

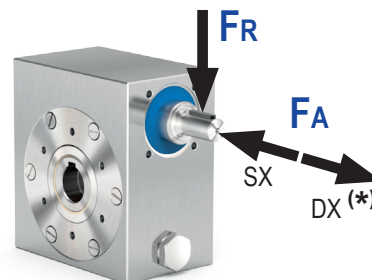

\* Strong axial loads in the DX direction are not allowed.

\* Non sono consentiti forti carichi assiali con direzione DX

Tab. 1

Tab. 2

41 Nm

145

PI45UN...

**Basic gearbox**  
Riduttore base

**Gearbox weight**  
peso riduttore **5.0 kg**

M. flanges	Kit code	øF	A
63B14	KI504047	90	73.5
71B14	KI504045	105	71

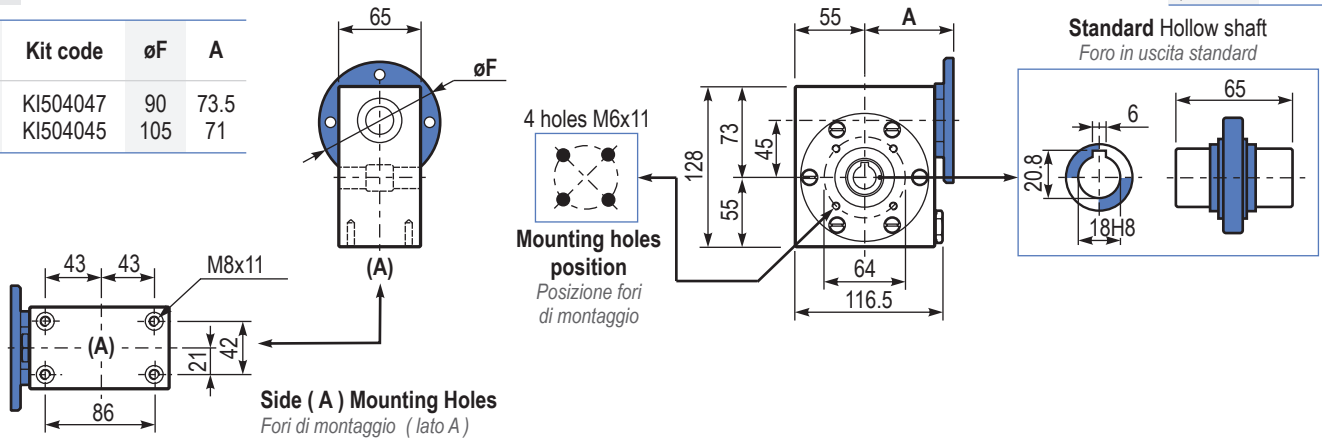

BI45UN...

**Modular base**  
Base modulare

PI45FL...

**Output flange**  
Flangia uscita

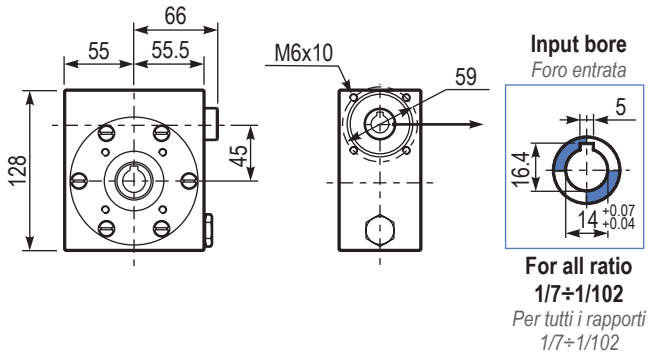

kit cod. KI459011

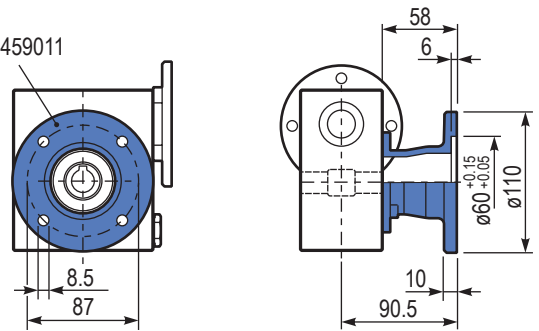

RI45UN...

**Input shaft**  
Albero in entrata

PI45BR...

**Reaction arm**  
Braccio di reazione

PI45.....S...

**Single Shaft**  
Albero lento semplice

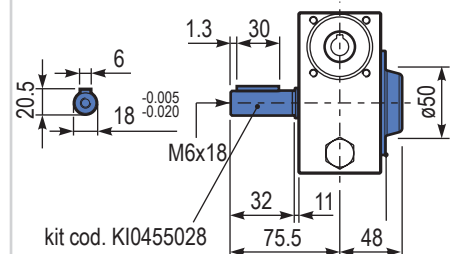
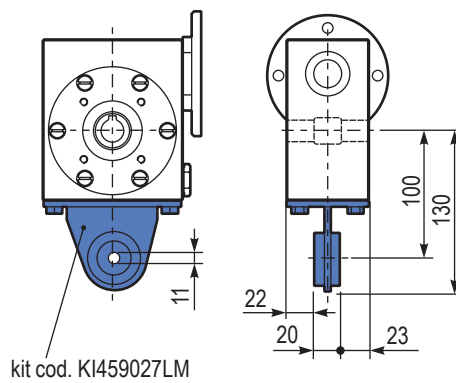
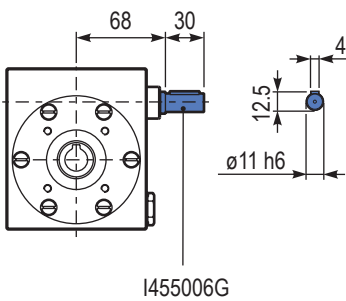

kit cod. KI450211  
**Protection cap**  
( on request )  
A richiesta coperchio di protezione

# 150

# 72 Nm

## VFI series Full stainless steel worm gearboxes

Riduttori a vite senza fine completamente in acciaio inox

Input speed ( $n_1$ ) = 1400 min<sup>-1</sup>

Output speed $n_2$ [min <sup>-1</sup> ]	Ratio $i$	Motor power $P_{1M}$ [kW]	Output torque $M_{2M}$ [Nm]	Service factor $f_s$	Nominal power $P_{1R}$ [kW]	Nominal torque $M_{2R}$ [Nm]	B5 motor flanges			B14 motor flanges			Dynamic efficiency RD	Tooth module [mm]	Ratios code
							-	-	-	-P 63	-Q 71	-R 80			
200	7	0.75	29	1.9	1.5	57				B-C	<b>B</b>		82	2.5	01
140	10	0.75	41	1.5	1.1	62				B-C	<b>B</b>		80	2.4	02
100	14	0.75	57	1.2	0.90	68				B-C	<b>B</b>		79	2.6	03
78	18	0.55	51	1.2	0.67	62				B-C	<b>B</b>		75	2.0	04
54	26	0.55	67	1.0	0.54	66				B-C	<b>B</b>		69	2.7	05
47	30	0.55	79	0.9	0.50	72				B-C	<b>B</b>		70	2.5	12
39	36	0.37	63	1.2	0.43	72				B-C			69	2.1	06
33	43	0.37	72	1.0	0.35	68				B-C			66	1.8	07
28	50	0.25	53	1.2	0.31	66				B-C			62	1.5	13
23	60	0.25	59	1.0	0.26	62				B-C			58	1.3	08
21	68	0.25	66	0.9	0.22	58				B-C			57	1.2	09
17.5	80	0.18	53	1.1	0.19	57				B-C			54	1.0	10
14	100	0.12	41	1.3	0.15	51				B-C			50	0.8	11

Motor flanges available  
Flange motore disponibili



B) Supplied with reduction bushing  
Fornito con bussola di riduzione



B) Available on request without reduction bushing  
Disponibile a richiesta senza bussola di riduzione



C) Motor flange holes position  
Posizione fori flangia motore

### Lubrication

Lubrificazione

Unit 150 is supplied with synthetic oil to assure long life lubrication. Food grade oil is available on request.

See Table 1 for lubrication and recommended quantity.

See Table 2 for possible radial and axial loads on the gearbox.

Il riduttore tipo 150 viene fornito con olio sintetico e lubrificazione tipo "long life".

Disponibile a richiesta olio alimentare.

Vedi Tabella 1 per oli e quantità consigliati.

Vedi Tabella 2 per i carichi radiali e assiali applicabili al riduttore.

Agip

Telium VSF 320

Shell

Omala S4 WE 320

**B3**  
Standard  
0.22 LT

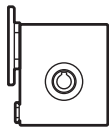

**B8**  
On request  
0.22 LT

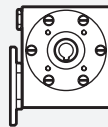

**B6**  
On request  
0.22 LT

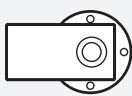

**V5**  
On request  
0.22 LT

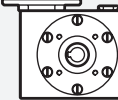

**B7**  
On request  
0.28 LT

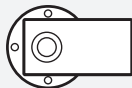

**V6**  
On request  
0.22 LT

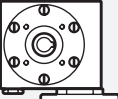

For more details on lubrication and plugs check our website.

Per maggiori dettagli su lubrificazione e tappi olio vedi il nostro sito web.

Tab. 1

### Radial and axial loads

Carichi radiali e assiali

#### Output shaft

Albero di uscita

$n_2$ [min <sup>-1</sup> ]	$F_A$ [N]	$F_R$ [N]
200	240	1200
150	280	1400
100	300	1500
75	340	1700
50	380	1900
25	480	2500
15	560	2800

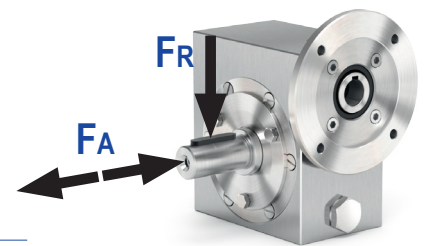

#### Input shaft

Albero in entrata

$n_1$ [min <sup>-1</sup> ]	$F_A$ [N]	$F_R$ [N]
1400	76	380

\* Strong axial loads in the DX direction are not allowed.

\* Non sono consentiti forti carichi assiali con direzione DX

Tab. 2



72  
Nm

150

PI50UN...

**Basic gearbox**  
*Riduttore base*

**Gearbox weight**  
*peso riduttore* **7.3 kg**

M. flanges	Kit code	øF	A
63B14	KI504047	90	78
71B14	KI504045	105	78
80B14	KI504046	120	

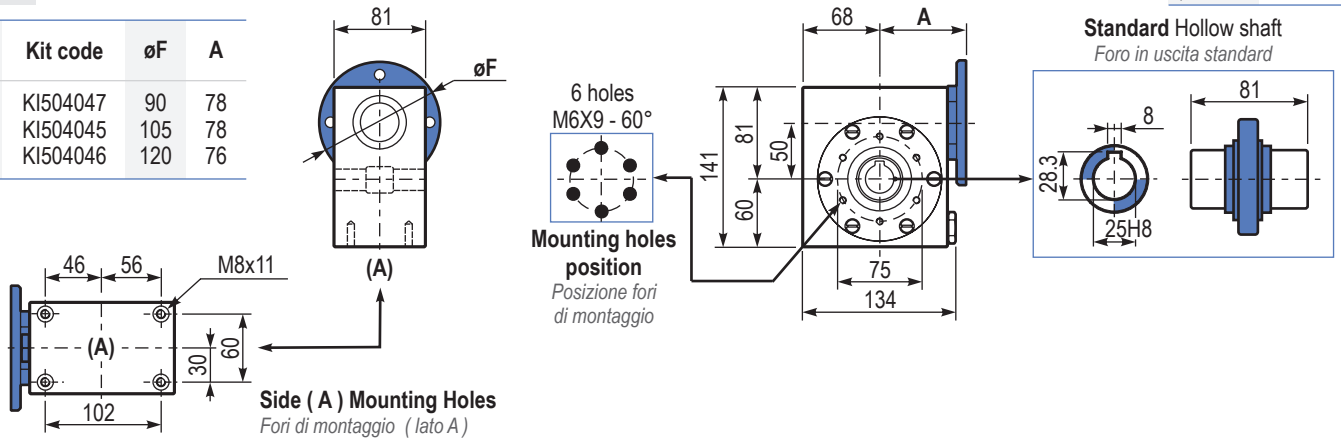

BI50UN...

**Modular base**  
*Base modulare*

**Input bore**  
*Foro entrata*

PI50FL...

**Output flange**  
*Flangia uscita*

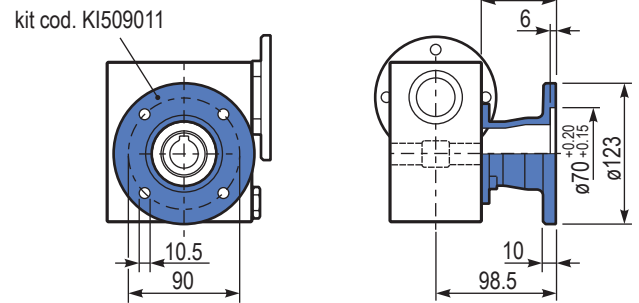
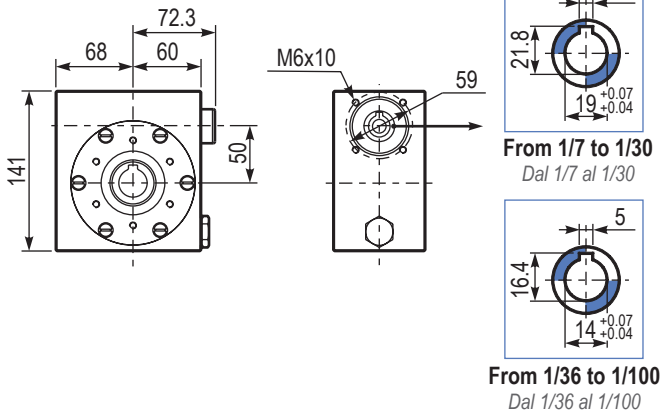

RI50UN...

**Input shaft**  
*Albero in entrata*

PI50BR...

**Reaction arm**  
*Braccio di reazione*

PI50.....S...

**Single Shaft**  
*Albero lento semplice*

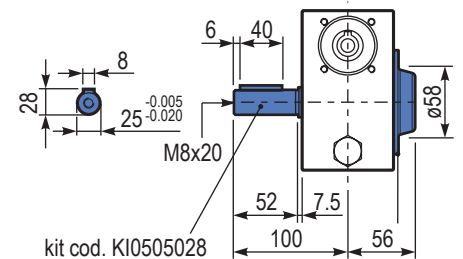
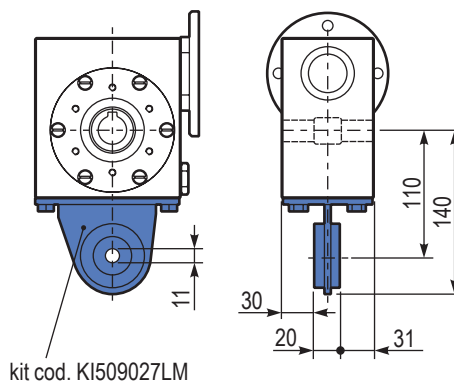
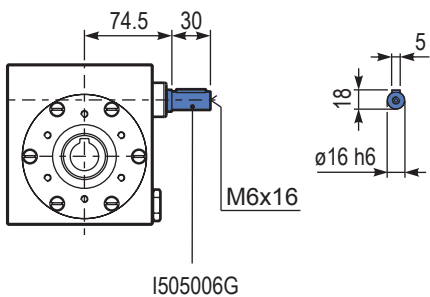

kit cod. KI500211  
**Protection cap**  
**( on request )**  
*A richiesta coperchio di protezione*

## VFI series Full stainless steel worm gearboxes

Riduttori a vite senza fine completamente in acciaio inox

Input speed ( $n_1$ ) = 1400 min<sup>-1</sup>

Output speed $n_2$ [min <sup>-1</sup> ]	Ratio $i$	Motor power $P_{1M}$ [kW]	Output torque $M_{2M}$ [Nm]	Service factor $f_s$	Nominal power $P_{1R}$ [kW]	Nominal torque $M_{2R}$ [Nm]	B5 motor flanges			B14 motor flanges			Dynamic efficiency RD	Tooth module [mm]	Ratios code
							-	-	-	-Q	-R	-T			
200	7	1.8	71	1.8	3.2	125				B-C	B-C		83	3.1	01
140	10	1.8	99	1.4	2.4	134				B-C	B-C		81	3.1	02
93	15	1.5	121	1.1	1.7	138				B-C	B-C		79	3.1	03
74	19	1.1	111	1.2	1.4	138				B-C	B-C		78	2.6	04
58	24	1.1	135	1.0	1.2	142				B-C	B-C		75	2.0	05
47	30	1.1	167	0.9	0.96	146				B-C	B-C		74	3.2	06
39	36	0.75	125	1.2	0.88	147				B-C	B-C		68	2.7	07
35	40	0.75	135	1.0	0.78	140				B-C	B-C		66	2.5	13
31	45	0.55	111	1.2	0.67	135				B-C	C		66	2.1	08
23	60	0.55	140	0.9	0.51	130				B-C	C		62	1.6	12
21	67	0.55	151	0.8	0.45	124				B-C	C		60	1.5	09
17.5	80	0.37	115	1.0	0.38	119				B-C	C		57	1.3	10
14.9	94	0.37	123	1.0	0.36	119				B-C	C		52	1.1	11

Motor flanges available  
Flange motore disponibili



B) Supplied with reduction bushing  
Fornito con bussola di riduzione

B) Available on request without reduction bushing  
Disponibile a richiesta senza bussola di riduzione



C) Motor flange holes position  
Posizione fori flangia motore

### Lubrication

Lubrificazione

Unit I63 is supplied with synthetic oil to assure long life lubrication.  
Food grade oil is available on request.

See Table 1 for lubrication and recommended quantity.

See Table 2 for possible radial and axial loads on the gearbox.

Il riduttore tipo I63 viene fornito con olio sintetico e lubrificazione tipo "long life".

Disponibile a richiesta olio alimentare.

Vedi Tabella 1 per oli e quantità consigliati.

Vedi Tabella 2 per i carichi radiali e assiali applicabili al riduttore.

Agip

Telium VSF 320

Shell

Omala S4 WE 320

B3

Standard  
0.60 LT

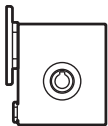

B8

On request  
0.60 LT

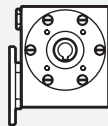

B6

On request  
0.60 LT

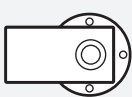

V5

On request  
0.60 LT

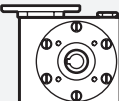

B7

On request  
0.82 LT

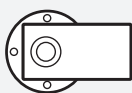

V6

On request  
0.60 LT

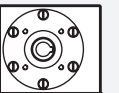

For more details on lubrication and plugs check our website.  
Per maggiori dettagli su lubrificazione e tappi olio vedi il nostro sito web.

Tab. 1

### Radial and axial loads

Carichi radiali e assiali

#### Output shaft

Albero di uscita

$n_2$ [min <sup>-1</sup> ]	$F_A$ [N]	$F_R$ [N]
200	360	1800
150	400	2000
100	460	2300
75	500	2500
50	600	3000
25	700	3800
15	800	4000

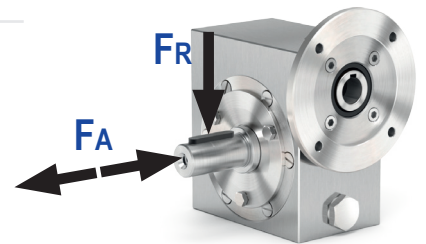

#### Input shaft

Albero in entrata

$n_1$ [min <sup>-1</sup> ]	$F_A$ [N]	$F_R$ [N]
1400	90	450

\* Strong axial loads in the DX direction are not allowed.

\* Non sono consentiti forti carichi assiali con direzione DX

Tab. 2

147  
Nm

163

PI63UN... **Basic gearbox**  
*Riduttore base*

Gearbox weight  
*peso riduttore* **14.6 kg**

M. flanges	Kit code	øF	A
71B14	KI634047	105	97
80B14	KI634046	120	99
90B14	KI634041	140	99

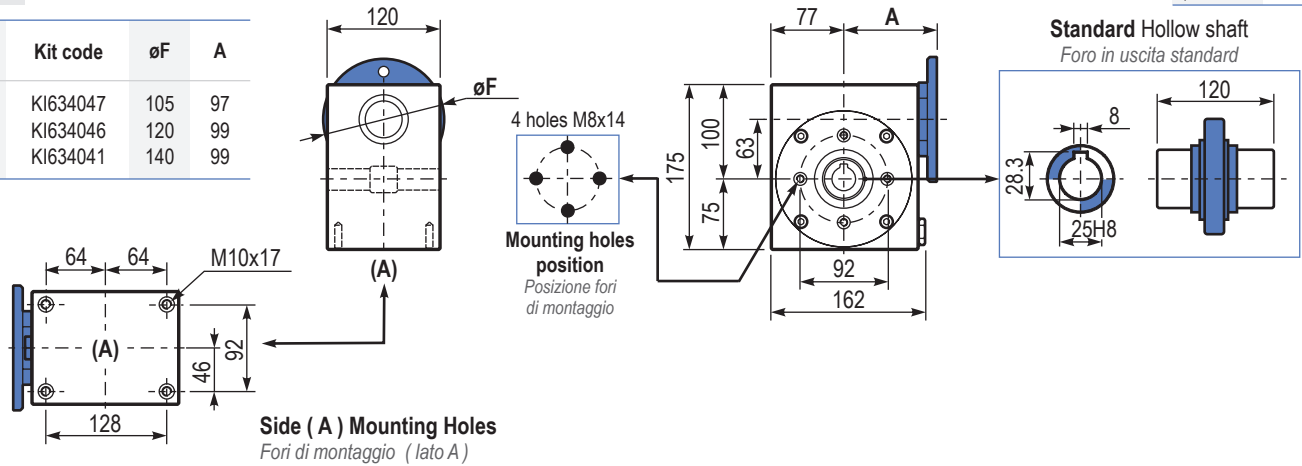

B163UN... **Modular base**  
*Base modulare*

**Input bore**  
*Foro entrata*

PI63FL... **Output flange**  
*Flangia uscita*

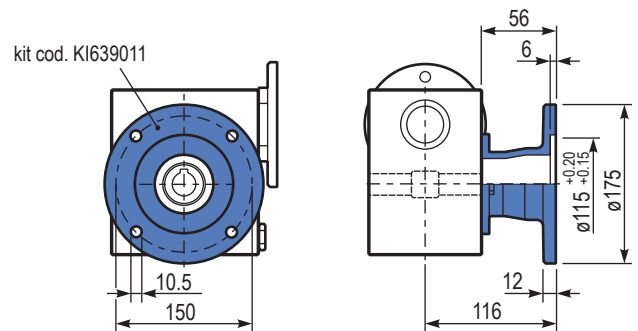
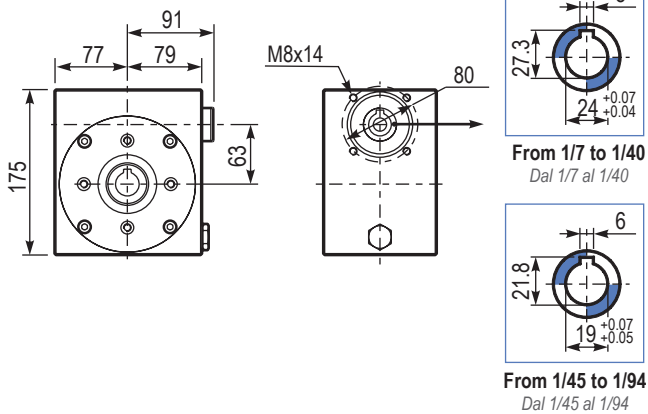

R163UN... **Input shaft**  
*Albero in entrata*

PI63BR... **Reaction arm**  
*Braccio di reazione*

PI63.....S... **Single Shaft**  
*Albero lento semplice*

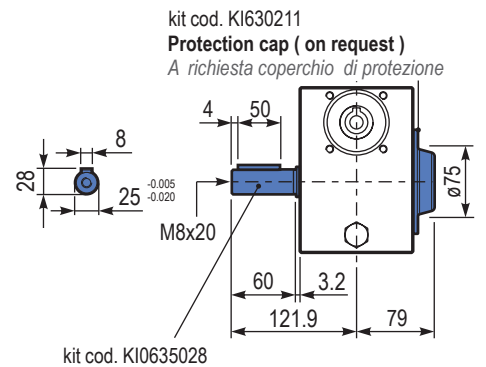
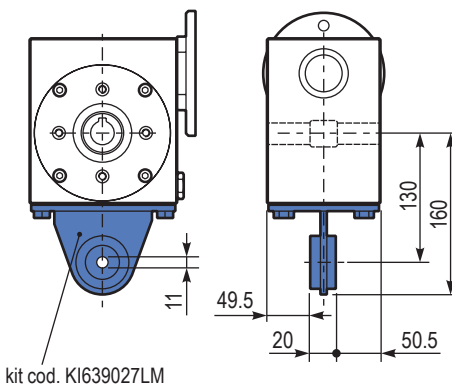
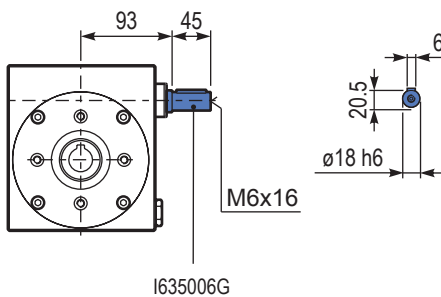

## VFI series Full stainless steel worm gearboxes

Riduttori a vite senza fine completamente in acciaio inox

Input speed ( $n_1$ ) = 1400 min<sup>-1</sup>

Output speed $n_2$ [min <sup>-1</sup> ]	Ratio $i$	Motor power $P_{1M}$ [kW]	Output torque $M_{2M}$ [Nm]	Service factor $f_s$	Nominal power $P_{1R}$ [kW]	Nominal torque $M_{2R}$ [Nm]	B5 motor flanges			B14 motor flanges			Dynamic efficiency RD	Tooth module [mm]	Ratios code
							-	-	-	-R	-T	-U			
200	7	4.0	168	1.5	6.1	257	-	-	-	B	B		88	4.23	01
140	10	4.0	218	1.3	5.2	284	-	-	-	B	B		80	4.2	02
100	14	3.0	223	1.4	4.1	305	-	-	-	B	B		78	4.5	03
70	20	2.2	237	1.2	2.7	294	-	-	-	B	B		79	3.4	04
64	22	2.2	258	1.1	2.5	294	-	-	-	B	B		78	3.1	05
50	28	2.2	315	1.1	2.4	347	-	-	-	B	B		75	4.7	06
37	38	1.5	276	1.2	1.8	336	-	-	-	B	B		71	3.5	07
30	46	1.5	320	1.0	1.5	326	-	-	-	B	B		68	3.1	08
27	52	1.1	258	1.1	1.2	289	-	-	-	B	B		66	2.7	09
21	67	1.1	327	0.9	0.97	289	-	-	-	B	B		65	2.1	10
18.9	74	0.75	220	1.2	0.91	268	-	-	-	B	B		58	1.9	11
14.6	96	0.55	191	1.3	0.70	242	-	-	-	B	B		53	1.5	12

**Motor flanges available**  
Flange motore disponibili

**B)** Supplied with reduction bushing  
Fornito con bussola di riduzione

**B)** Available on request without reduction bushing  
Disponibile a richiesta senza bussola di riduzione

**C)** Motor flange holes position  
Posizione fori flangia motore

### Lubrication

Lubrificazione

Unit I85 is supplied with synthetic oil to assure long life lubrication. Food grade oil is available on request.

See Table 1 for lubrication and recommended quantity.

See Table 2 for possible radial and axial loads on the gearbox.

Il riduttore tipo I85 viene fornito con olio sintetico e lubrificazione tipo "long life".

Disponibile a richiesta olio alimentare.

Vedi Tabella 1 per oli e quantità consigliati.

Vedi Tabella 2 per i carichi radiali e assiali applicabili al riduttore.

**Agip**

Telium VSF 320

**Shell**

Omala S4 WE 320

**B3**

Standard  
1.40 LT

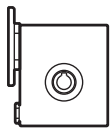

**B8**

On request  
1.40 LT

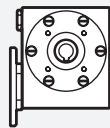

**B6**

On request  
1.40 LT

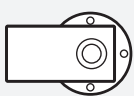

**V5**

On request  
1.40 LT

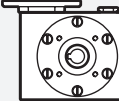

**B7**

On request  
1.70 LT

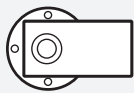

**V6**

On request  
1.40 LT

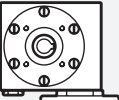

For more details on lubrication and plugs check our website.  
Per maggiori dettagli su lubrificazione e tappi olio vedi il nostro sito web.

### Radial and axial loads

Carichi radiali e assiali

#### Output shaft

Albero di uscita

$n_2$ [min <sup>-1</sup> ]	$F_A$ [N]	$F_R$ [N]
200	500	2500
150	580	2900
100	600	3000
75	700	3500
50	800	4000
25	1000	5000
15	1160	5800

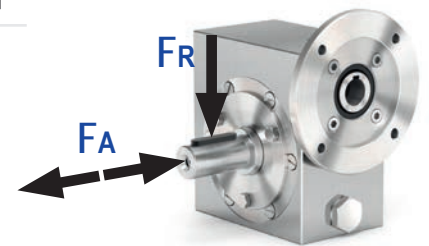

#### Input shaft

Albero in entrata

$n_1$ [min <sup>-1</sup> ]	$F_A$ [N]	$F_R$ [N]
1400	130	650

\* Strong axial loads in the DX direction are not allowed.

\* Non sono consentiti forti carichi assiali con direzione DX

347  
Nm

185

PI85UN... Basic gearbox  
Riduttore base

Gearbox weight  
peso riduttore 23.3 kg

M. flanges	Kit code	øF	A
80B14	KI854046	120	118
90B14	KI854045	140	118
100-112B14	KI854041	160	127

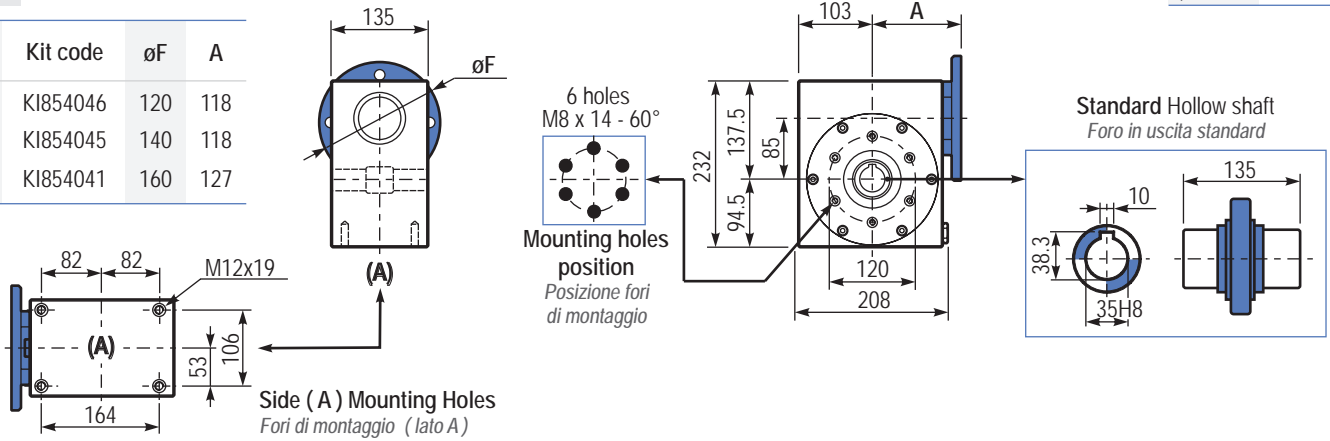

BI85UN... Modular base  
Base modulare

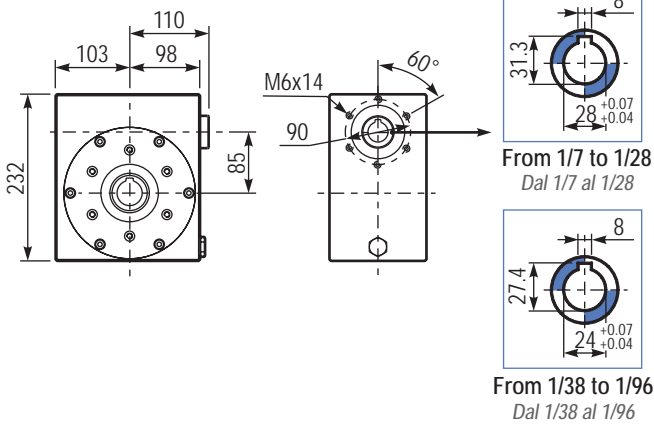

PI85FL... Output flange  
Flangia uscita

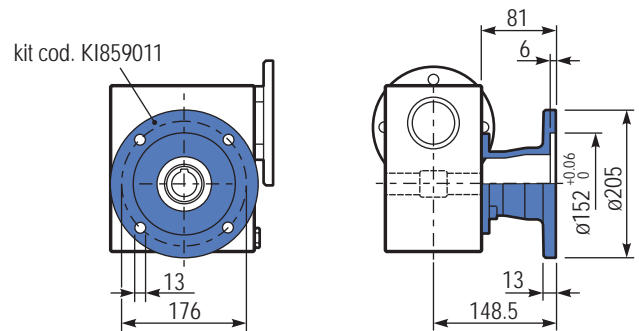

RI85UN... Input shaft  
Albero in entrata

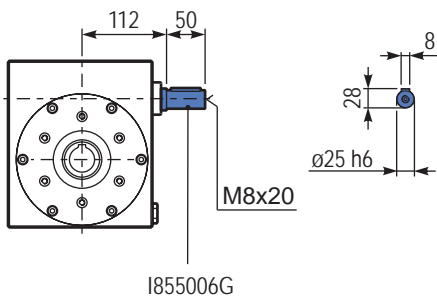

PI85BR... Reaction arm  
Braccio di reazione

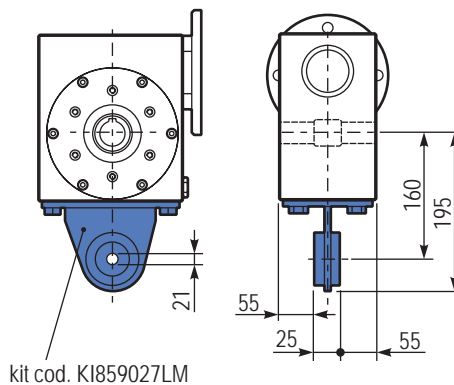

PI85.....S... Single Shaft  
Albero lento semplice

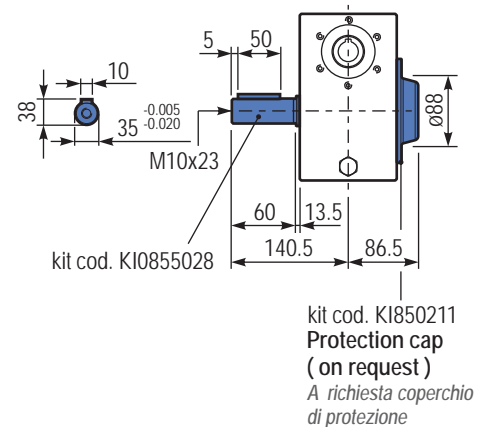

## VFI series Full stainless steel worm gearboxes

Riduttori a vite senza fine completamente in acciaio inox

Input speed ( $n_1$ ) = 1400 min<sup>-1</sup>

Output speed $n_2$ [min <sup>-1</sup> ]	Ratio $i$	Motor power $P_{1M}$ [kW]	Output torque $M_{2M}$ [Nm]	Service factor $f_s$	Nominal power $P_{1R}$ [kW]	Nominal torque $M_{2R}$ [Nm]	B5 motor flanges			B14 motor flanges			Dynamic efficiency RD	Tooth module [mm]	Ratios code
							-	-	-	-R	-T	-U			
200	7	4.0	168	2.9	11.5	483	-	-	-	B	B		88	5.5	01
140	10	4.0	235	2.2	9.0	525	-	-	-	B	B		86	5.4	02
88	16	4.0	358	1.5	6.0	536	-	-	-	B	B		82	5.3	03
70	20	4.0	447	1.2	4.9	546	-	-	-	B	B		82	4.5	04
61	23	3.0	377	1.4	4.1	515	-	-	-	B	B		80	3.9	05
47	30	3.0	467	1.4	4.2	651	-	-	-	B	B		76	5.6	06
37	38	3.0	583	1.1	3.3	641	-	-	-	B	B		75	4.7	07
31	45	2.2	493	1.2	2.7	599	-	-	-	B	B		73	4.0	08
26	53	2.2	557	1.1	2.5	620	-	-	-	B	B		70	3.5	09
22	64	1.5	452	1.2	1.8	536	-	-	-	B			69	2.9	10
16.7	84	1.1	410	1.2	1.3	494	-	-	-	B			65	2.2	11
14.1	99	1.1	446	1.1	1.2	483	-	-	-	B			60	1.9	12

**Motor flanges available**  
Flange motore disponibili

**B) Supplied with reduction bushing**  
Fornito con bussola di riduzione

**B) Available on request without reduction bushing**  
Disponibile a richiesta senza bussola di riduzione

**C) Motor flange holes position**  
Posizione fori flangia motore

### Lubrication

Lubrificazione

Unit I11 is supplied with synthetic oil to assure long life lubrication. Food grade oil is available on request.

See Table 1 for lubrication and recommended quantity.

See Table 2 for possible radial and axial loads on the gearbox.

Il riduttore tipo I11 viene fornito con olio sintetico e lubrificazione tipo "long life".

Disponibile a richiesta olio alimentare.

Vedi Tabella 1 per oli e quantità consigliati.

Vedi Tabella 2 per i carichi radiali e assiali applicabili al riduttore.

**Agip**

Telium VSF 320

**Shell**

Omala S4 WE 320

**B3**  
Standard  
3.50 LT

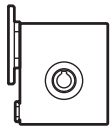

**B8**  
On request  
2.10 LT

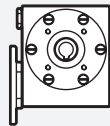

**B6**  
On request  
2.50 LT



**V5**  
On request  
1.60 LT

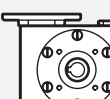

**B7**  
On request  
2.50 LT



**V6**  
On request  
1.60 LT



For more details on lubrication and plugs check our website.  
Per maggiori dettagli su lubrificazione e tappi olio vedi il nostro sito web.

### Radial and axial loads

Carichi radiali e assiali

#### Output shaft

Albero di uscita

$n_2$ [min <sup>-1</sup> ]	$F_A$ [N]	$F_R$ [N]
200	600	2900
150	700	3300
100	750	3600
75	800	4000
50	920	4600
25	1200	6000
15	1400	7000

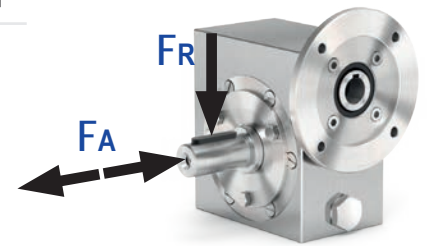

#### Input shaft

Albero in entrata

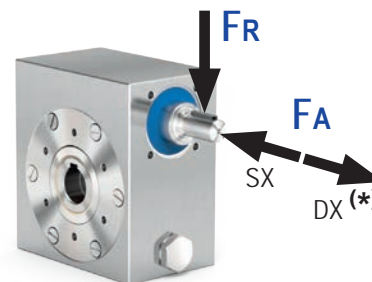

$n_1$ [min <sup>-1</sup> ]	$F_A$ [N]	$F_R$ [N]
1400	228	1140

\* Strong axial loads in the DX direction are not allowed.

\* Non sono consentiti forti carichi assiali con direzione DX

PI11UN... Basic gearbox  
Riduttore base

Gearbox weight  
peso riduttore 38.5 kg

M. flanges	Kit code	øF	A
80B14	KI854046	120	137.5
90B14	KI854045	140	137.5
100-112B14	KI854041	160	146.5

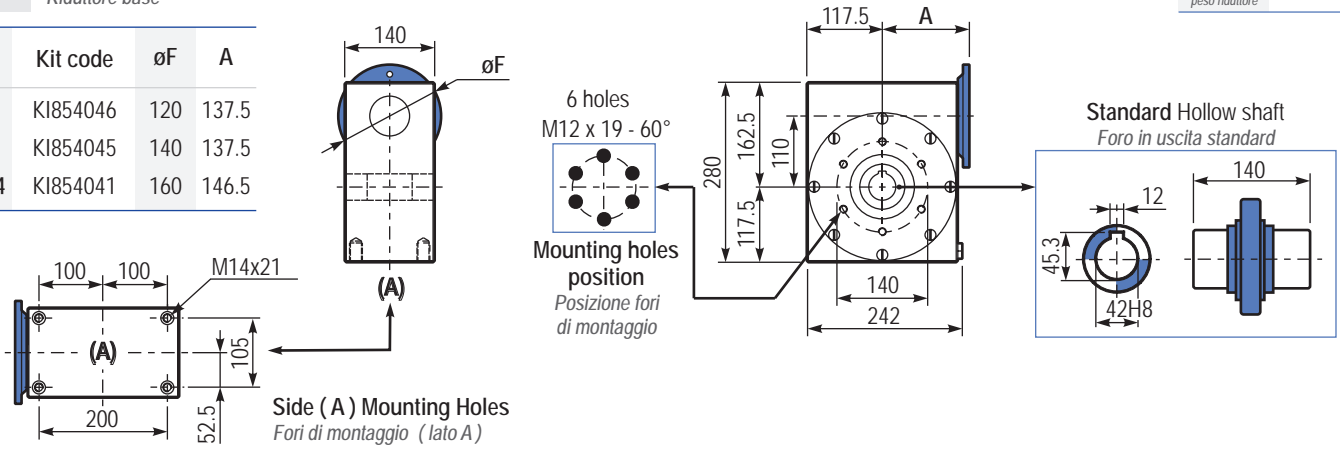

B111UN... Modular base  
Base modulare

PI11BR... Reaction arm  
Braccio di reazione

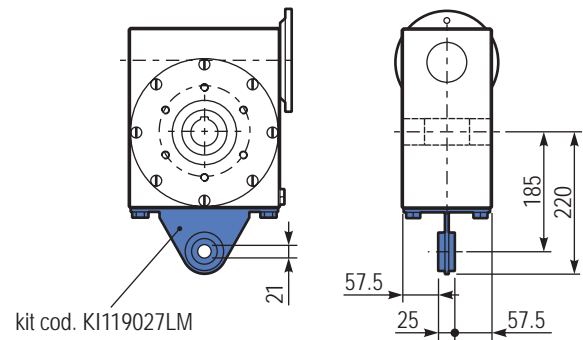
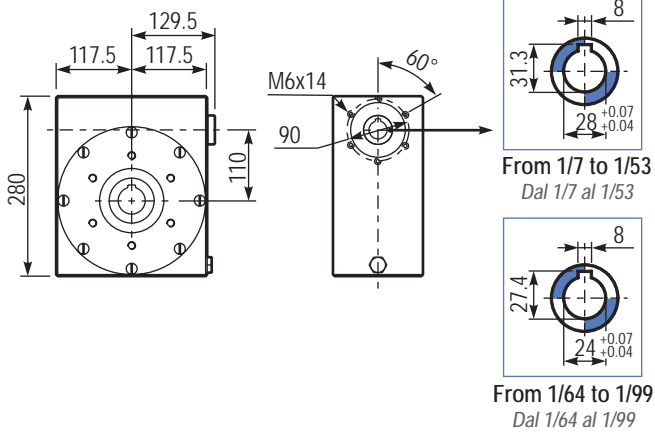

R111UN... Input shaft  
Albero in entrata

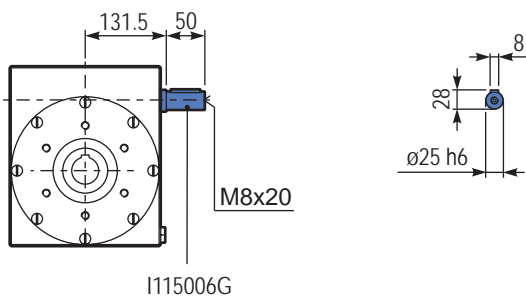





# I RCI series Full stainless steel ratio multipliers

*Riduttori ad uno stadio completamente in acciaio inox*

Section **8**  
Sezione 8

This range is



certified

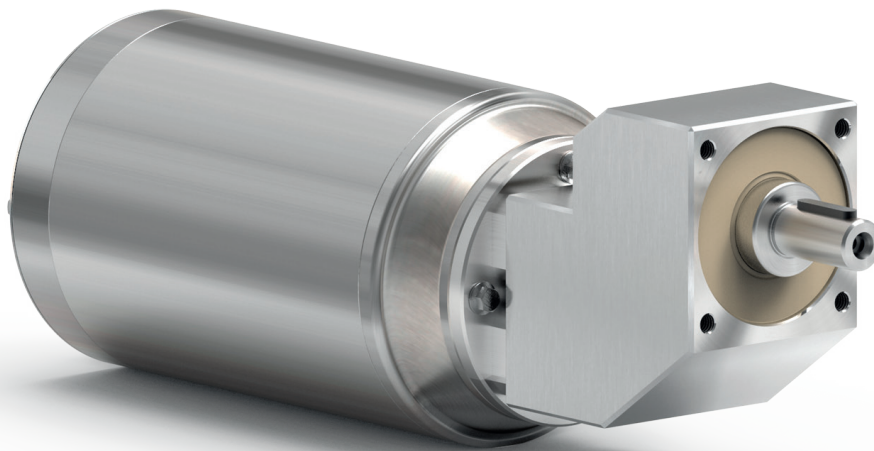

# FEATURES

Caratteristiche

## RCI series Full stainless steel ratio multipliers

*Riduttori ad uno stadio completamente in acciaio inox*

Type <i>Tipo</i>	Torque <i>Coppia</i>	Center distance <i>Interasse</i>	Input power <i>Potenza in entrata</i>	Output shaft <i>Albero in uscita</i>
411I	38 Nm	38 mm	0.37 ÷ 1.5 kW	ø19 mm

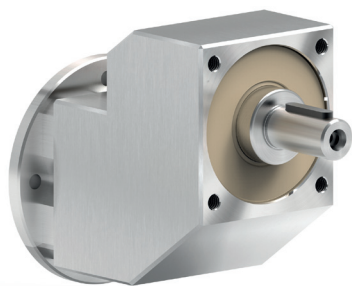

This product is:

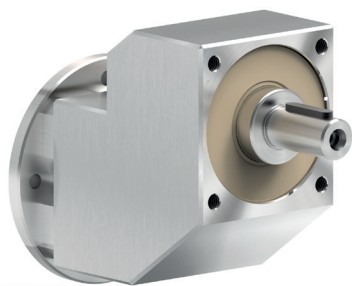

Output shaft is produced in AISI 316L.

*Albero in uscita in AISI 316L*



Hardened and ground gears.

*Ingranaggi temprati e rettificati.*

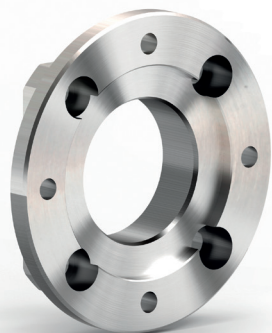

**Fully modular IEC flanges and compact NEMA C motor flanges.**

*Flange IEC e NEMA completamente modulari.*

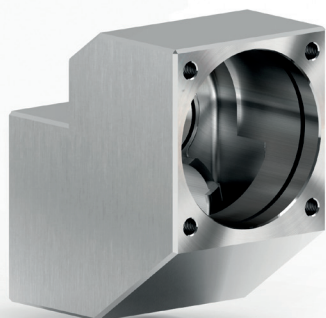

**Special high tech full stainless steel housing with accurate finishing and strong rigidity.**

*Finitura speciale su una cassa inox che presenta un'alta rigidità strutturale.*

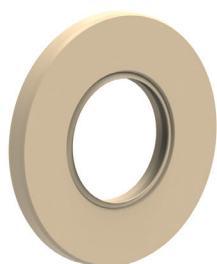



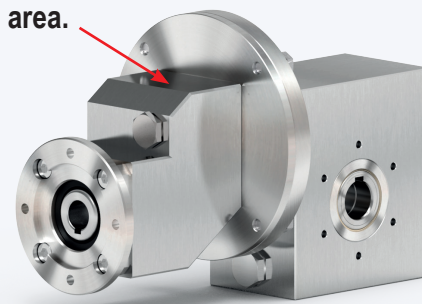

**Standard FPM (fkm) seals are used, since seals will be in a closed area.**





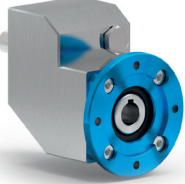

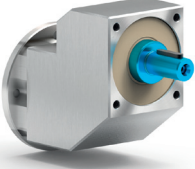

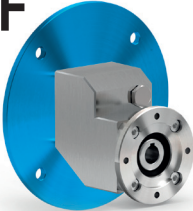
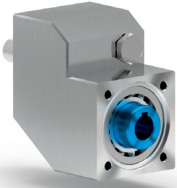

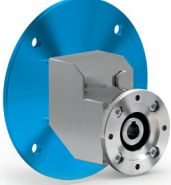
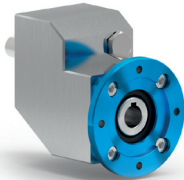
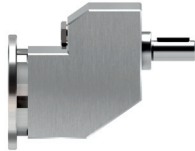
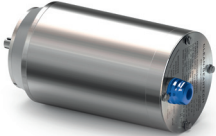
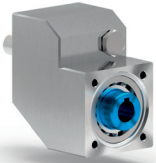
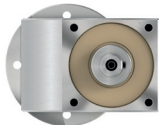
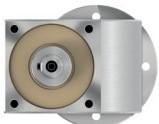
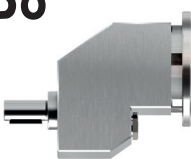
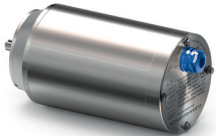

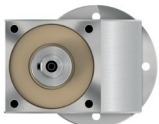
*Anelli di tenuta FPM(fkm) standard.*

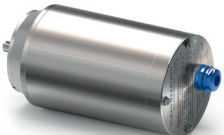
# How to order

Codifica

<b>P</b>	<b>411I</b>	<b>-F</b>	<b>1.57</b>	<b>C</b>
Type <i>Tipo</i>	Size <i>Grandezza</i>	Mounting <i>Montaggio</i>	Ratio <i>Rapporto</i>	Output shaft <i>Albero lento</i>
<b>P</b> 	<b>411I</b>	<b>-N</b> 	See technical data table <i>Vedi tabelle dati tecnici</i>	
<b>M</b> 		<b>-F</b> 		<b>C</b> -> ø19
<b>B</b> 				

4	-T	B3	-	With Type M specify terminal box position <i>Con tipo M specificare posizione morsettiera</i>
Output flange <i>Flangia uscita</i>	Motor size <i>Grandezza motore</i>	Mounting position <i>Posizione di montaggio</i>	Input bore <i>Foro entrata</i>	Terminal box position <i>Posizione morsettiera</i>
 <p><b>N</b> Without flange <i>Senza flangia</i></p> <p><b>4</b> -&gt; <math>\varnothing 200</math></p>	<p><b>Flange</b> <i>Flange</i></p>  <p>IEC B14</p> <p><b>-Q</b> -&gt; 71 B14 (<math>\varnothing 105</math>)</p> <p><b>-R</b> -&gt; 80 B14 (<math>\varnothing 120</math>)</p> <p><b>-T</b> -&gt; 90 B14 (<math>\varnothing 140</math>)</p>	<p><b>B3</b></p> 	<p><b>-</b> Standard bore <i>Foro standard</i></p>	<p><b>A</b></p> 
<p><b>Without flange</b> <i>Senza flangia</i></p>  <p><b>-1</b> -&gt; <math>\varnothing 14</math> (71 B5)</p> <p><b>-2</b> -&gt; <math>\varnothing 19</math> (80 B5)</p> <p><b>-3</b> -&gt; <math>\varnothing 24</math> (90 B5)</p>	<p><b>B6</b></p> 	<p><b>B7</b></p> 	<p><b>B8</b></p> 	<p><b>B</b></p> 
<p><b>V5</b></p> 	<p><b>B7</b></p> 	<p><b>V6</b></p> 	<p><b>C</b></p> 	<p><b>D</b></p> 
<p><b>V8</b></p> 	<p><b>V8</b></p> 	<p><b>V8</b></p> 	<p><b>D</b></p> 	<p><b>D</b></p> 

# Useful formulas

Formule utili

## Required power - Potenza richiesta

Lifting - Sollevamento

Rotation - Rotazione

Linear movement - Traslazione

$$P_{[kW]} = \frac{M_{[Kg]} \cdot g_{[9.81]} \cdot v_{[m/s]}}{1000}$$

$$P_{[kW]} = \frac{M_{[Nm]} \cdot n_{[rpm]}}{9550}$$

$$P_{[kW]} = \frac{F_{[N]} \cdot v_{[m/s]}}{1000}$$

## Torque - Coppia

$$M_{[Nm]} = \frac{9550 \cdot P_{[kW]}}{n_{[rpm]}}$$

$$M_{[lb\ in]} = \frac{63030 \cdot P_{[HP]}}{n_{[rpm]}}$$

## Radial loads - Carichi radiali

**Radial load generated by external transmissions keyed onto input and/or output shafts.**

Forza radiale generata da organi di trasmissione calettati sugli alberi di ingresso e/o uscita.

$$FR_{[N]} = \frac{M_{[Nm]} \cdot 2000}{d_{[mm]}} \cdot f_k$$

$$FR_{[N]} = \frac{M_{[lb\ in]} \cdot 8.9}{d_{[in]}} \cdot f_k$$

**M:** Output torque - *Momento torcente*

**d:** Diam. of driving element - *Diametro primitivo*

**f<sub>k</sub>:** Factor - *Coefficiente di trasformazione*

**1.15:** Gearwheels - *Ingranaggi*

**1.25:** Chain sprochets - *Catena*

**1.75:** Narrow v-belt pulley - *Cinghia Trapezoidale*

**2.50:** Flat-belt pulley - *Cinghia piatta*

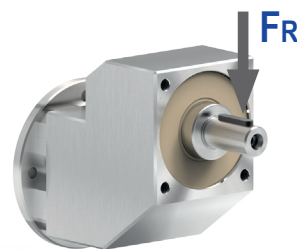

**If your application requires higher radial loads, contact our technical office. Higher loads may be possible.**

Nel caso la vostra applicazione richieda carichi radiali superiori consultare il nostro ufficio tecnico, valori maggiori possono essere accettati.

# How to select a gearbox

Come selezionare un riduttore

## A Select required torque (according to service factor)

Seleziona la coppia desiderata (comprensiva del fattore di servizio)

## B Select output speed

Seleziona la velocità in uscita

## C Select gear ratio in the line corresponding to the chosen motor power

Sulla riga corrispondente alla motorizzazione prescelta si può rilevare il rapporto di riduzione

## D Select motor flange available (if requested)

Scegli la flangia disponibile (se richiesta)

Gear size  
Grandezza  
riduttore

C

Ratio  
Rapporto

Transmitted torque  
Momento torcente  
trasmesso

Nominal power  
Potenza nominale

Flange code  
Codice flangia

Input speed  
Velocità in entrata



4111

38  
Nm

## RCI series Full stainless steel ratio multipliers

Riduttori ad uno stadio completamente in acciaio inox

Input speed ( $n_1$ ) = 1400 min<sup>-1</sup>

Output speed $n_2$ [min <sup>-1</sup> ]	Ratio i	Motor power $P_{1M}$ [kW]	Output torque $M_{2M}$ [Nm]	Service factor f.s	Nominal power $P_{1R}$ [kW]	Nominal torque $M_{2R}$ [Nm]	B5 motor flanges		B14 motor flanges			Output shaft 	Ratios code 
							-	-	-Q 71	-R 80	-T 90		
891	1.57	1.5	16	1.3	1.9	20	-	-	C	C	-	2844	01
493	2.84	1.5	28	1.2	1.8	35	-	-	C	C	-	1954	02
425	3.29	1.5	33	1.2	1.7	38	-	-	C	C	-	1756	03
362	3.87	1.5	39	1.0	1.5	40	-	-	C	C	-	1558	04
303	4.62	1.5	46	1.0	1.5	47	-	-	C	C	standard ø19	1360	05
222	6.30	1.1	46	1.0	1.1	46	-	-	C	C	-	1063	06
170	8.22	0.55	30	1.3	0.69	38	-	-	C	C	-	974	07
129	10.86	0.37	27	1.0	0.39	28	-	-	C	C	-	776	08

B Output speed  
Velocità in uscita

Motor power  
Potenza motore

Service factor  
Fattore di servizio

A Nominal torque  
Momento torcente  
nominale

Output shaft diam.  
Diametro albero uscita

Notes  
Note

### Type of load and starts per hour

Tipo di carico e avviamenti per ora

Oper. hours per day  
Ore di funz. giorn.

		Oper. hours per day		
		3h	10h	24h
Continuous or intermittent application with start / hour Applicazione continua o intermittente con numero operazioni/ora	Uniform - <i>Uniforme</i>	0.8	1	1.25
	Moderate - <i>Moderato</i>	1	1.25	1.5
	Heavy - <i>Forte</i>	1.25	1.5	1.75
Intermittent application with start / hour Applicazione intermittente con numero operazioni/ora	Uniform - <i>Uniforme</i>	1	1.25	1.5
	Moderate - <i>Moderato</i>	1.25	1.5	1.75
	Heavy - <i>Forte</i>	1.5	1.75	2.15

D Motor flange available  
Flange disponibili

B) Mounting with reduction bushing  
Montaggio con boccola di riduzione

C) Motor flange holes position/terminal box position  
Posizione fori flangia/basetta motore

B) Available without reduction bushing  
Disponibile anche senza boccola

# 4111



## 38 Nm

# RCI series Full stainless steel ratio multipliers

Riduttori ad uno stadio completamente in acciaio inox

The dynamic efficiency is **0.98** for all ratios

Input speed ( $n_1$ ) = 1400 min<sup>-1</sup>

Output speed $n_2$ [min <sup>-1</sup> ]	Ratio $i$	Motor power $P_{1M}$ [kW]	Output torque $M_{2M}$ [Nm]	Service factor f.s	Nominal power $P_{1R}$ [kW]	Nominal torque $M_{2R}$ [Nm]	B5 motor flanges			B14 motor flanges			Output shaft 	Ratios code 
							-	-	-	-Q	-R	-T		
891	<b>1.57</b>	1.5	16	1.3	<b>1.9</b>	<b>20</b>	-	-	-	C	C		standard ø19	01
493	<b>2.84</b>	1.5	28	1.2	<b>1.8</b>	<b>35</b>	-	-	-	C	C			02
425	<b>3.29</b>	1.5	33	1.2	<b>1.7</b>	<b>38</b>	-	-	-	C	C			03
362	<b>3.87</b>	1.5	39	1.0	<b>1.5</b>	<b>40</b>	-	-	-	C	C			04
303	<b>4.62</b>	1.5	46	1.0	<b>1.5</b>	<b>47</b>	-	-	-	C	C			05
222	<b>6.30</b>	1.1	46	1.0	<b>1.1</b>	<b>46</b>	-	-	-	C	C			06
170	<b>8.22</b>	0.55	30	1.3	<b>0.69</b>	<b>38</b>	-	-	-	C	C			07
129	<b>10.86</b>	0.37	27	1.0	<b>0.39</b>	<b>28</b>	-	-	-	C	C			08

Motor flanges available  
Flange motore disponibili

 B) Supplied with reduction bushing  
Fornito con bussola di riduzione

B) Available on request without reduction bushing  
Disponibile a richiesta senza bussola di riduzione

 C) Motor flange holes position  
Posizione fori flangia motore

## Lubrication

Lubrificazione

Unit 4111 is supplied with synthetic oil to assure long life lubrication.  
Food grade oil is available on request.

See Table 1 for lubrication and recommended quantity.

See Table 2 for possible radial and axial loads on the gearbox.

Il riduttore tipo 4111 viene fornito con olio sintetico e lubrificazione tipo "long life".

Disponibile a richiesta olio alimentare.

Vedi Tabella 1 per oli e quantità consigliati.

Vedi Tabella 2 per i carichi radiali e assiali applicabili al riduttore.

**Oil quantity for  
all positions:  
0.14Lt.**

Quantità olio per tutte  
le posizioni: 0.14Lt

**Agip**  
Telium VSF 320

**Shell**  
Omala S4 WE 320

## Radial and axial loads

Carichi radiali e assiali

### Output shaft

Albero di uscita

$n_2$ [min <sup>-1</sup> ]	$F_A$ [N]	$F_R$ [N]
700	182	910
600	200	1000
400	230	1150
300	250	1250
200	290	1450
140	320	1600

$$F_{eq} = F_R \cdot \frac{48.5}{X + 28.5}$$

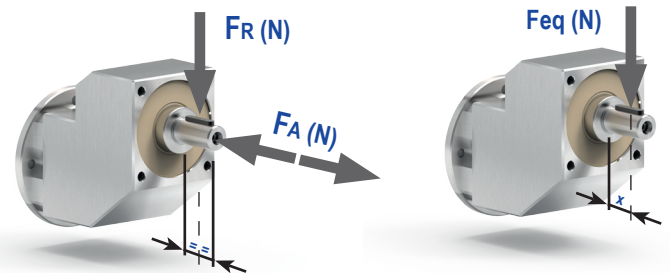

Tab. 1

Tab. 2



38  
Nm

4111

**P4111-N...** Basic gearbox  
*Riduttore base*

Gearbox weight  
*peso riduttore* **5.5 kg**

**Output shafts** / *albero di uscita*

	Shaft - d1	p1	h1	x
<b>Standard</b>	∅ 19x40	6	21.5	M6x16

**Input flanges** / *flange di entrata*

	Kit code	k1	g6
<b>71 B14</b>	KI634047	128.5	105
<b>80 B14</b>	KI634046	129.5	120
<b>90 B14</b>	KI634041	130.5	140

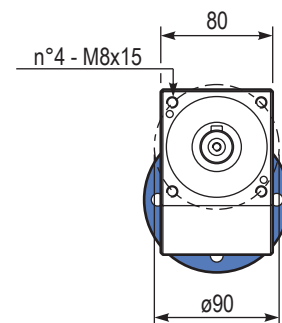
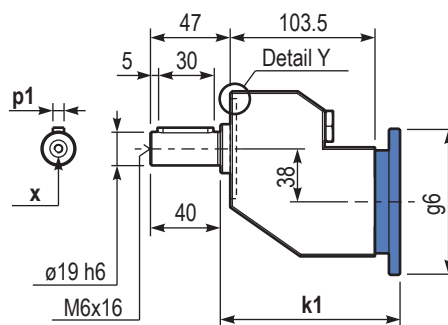
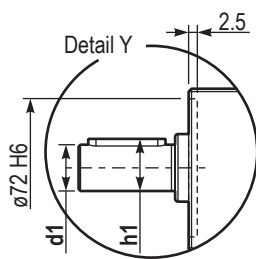

**P4111-F...** Output flange  
*Flangia di uscita*

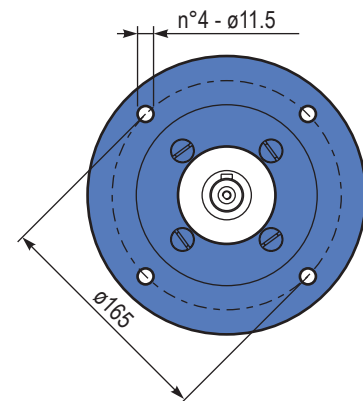
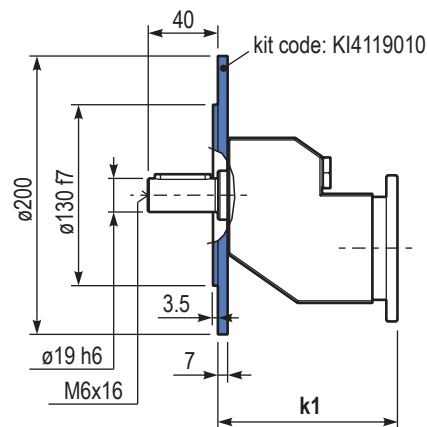



# I BVI series Full stainless steel helical bevel gearboxes

*Riduttori a coppia conica completamente in acciaio inox*

Section **9**  
Sezione 9

This range is  IP69K  **ATEX**  
(on request)  **CE**  NSF  
COMPONENT certified



# FEATURES

Caratteristiche

## BVI series

### Full stainless steel helical bevel gearboxes

Riduttori a coppia conica completamente in acciaio inox

Type <i>Tipo</i>	Torque <i>Coppia</i>	Center distance <i>Interasse</i>	Input power <i>Potenza in entrata</i>	Hollow output shaft <i>Albero cavo in uscita</i>
X42I	150 Nm	-	0.25 ÷ 1.5 kW	ø25
X62I	410 Nm	-	0.75 ÷ 4.0 kW	ø35

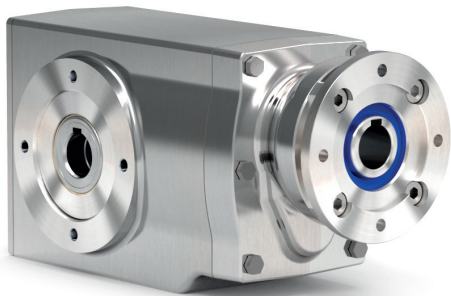

This product is:

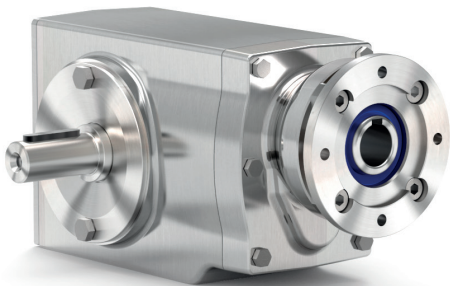

Output shaft in AISI 316L and special cover for full seals protection.

*Albero in uscita in AISI 316L e coperchietto protettivo per anelli di tenuta.*

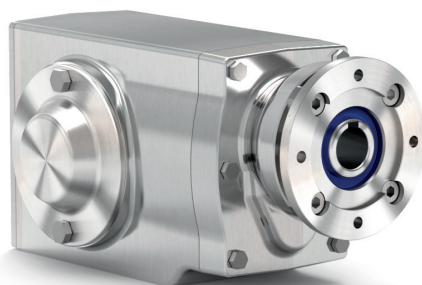

Closed protection cap with o-ring in AISI 316L.

*Coperchietto di protezione chiuso in AISI 316L con o-ring.*

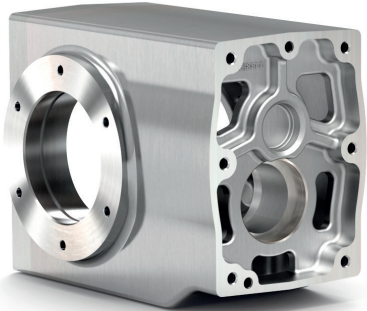

**Special high tech full stainless steel housing with accurate finishing and strong rigidity.**

*Finitura speciale su una cassa inox che presenta un'alta rigidità strutturale.*



**Fully modular IEC flanges and compact NEMA C motor flanges.**

*Flange IEC e NEMA completamente modulari.*

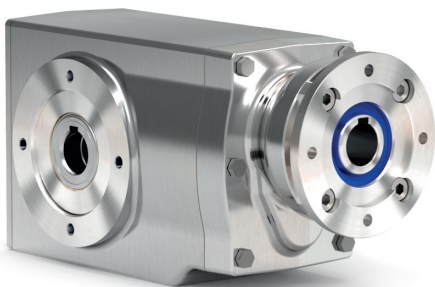

**Stainless steel 316L hollow input/output shaft.  
Viton seals with stainless steel 316L shield.**



*Albero cavo in uscita in acciaio inox in AISI 316L. Anelli di tenuta in viton con schermo protettivo in acciaio inox in AISI 316L.*











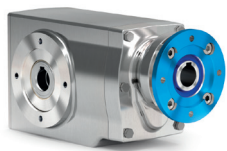
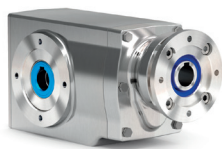
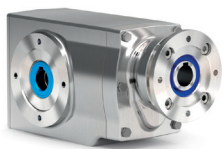
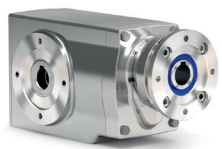

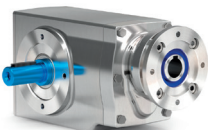
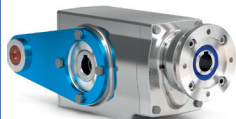
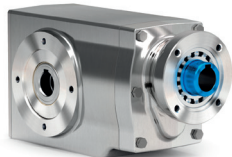
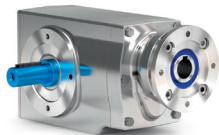
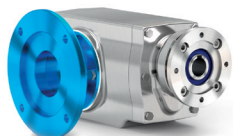

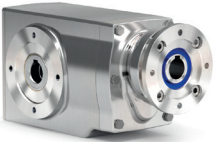
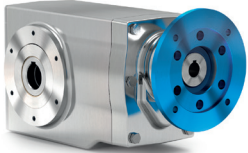
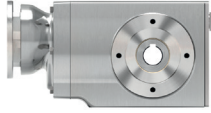

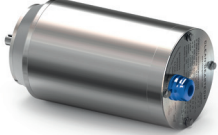
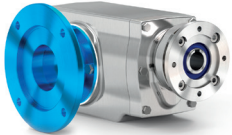
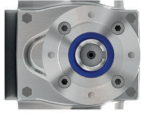
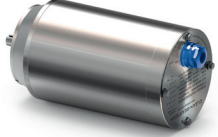
**Hardened and ground gears.**

*Ingranaggi temprati e rettificati.*

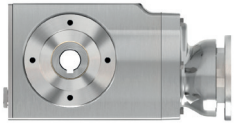
# How to order

Codifica

<b>M</b>	<b>X42I</b>	<b>I</b>	<b>7.29</b>	<b>-C</b>	<b>BR</b>
Type <i>Tipo</i>	Size <i>Grandezza</i>	Hub <i>Mozzo</i>	Ratio <i>Rapporto</i>	Output shaft <i>Albero uscita</i>	Type <i>Tipo</i>
<p><b>P</b></p> 	<p><b>X42I</b> <b>X62I</b></p>	<p><b>I</b> Hollow output shaft <i>Foro albero uscita</i></p> 	<p>See technical data table <i>Vedi tabelle dati tecnici</i></p>	<p>Hollow output shaft <i>Foro albero uscita</i></p> 	<p><b>FB</b> Universal <i>Forma base</i></p> 
<p><b>M</b></p> 		<p><b>A</b> Single output shaft <i>Albero uscita singolo</i></p> 		<p>→ Standard X42I <b>-C</b> → <math>\varnothing 25</math></p> <p>X62I <b>-E</b> → <math>\varnothing 35</math></p>	<p><b>BR</b> Reaction arm <i>Braccio di reazione</i></p> 
<p><b>B</b></p> 				<p>Single output shaft <i>Albero uscita singolo</i></p>  <p>X42I <b>-L</b> → <math>\varnothing 25</math></p> <p>X62I <b>-N</b> → <math>\varnothing 35</math></p>	<p><b>-F</b> Output flange <i>Flangia uscita</i></p> 

<b>N</b>	<b>-T</b>	<b>B3</b>	<b>E</b>	With Type M specify terminal box position <i>Con tipo M specificare posizione morsettiera</i>
Output flange <i>Flangia in uscita</i>	Motor size <i>Grandezza motore</i>	Mounting position <i>Posizione di montaggio</i>	Input bore <i>Foro entrata</i>	Terminal box position <i>Posizione morsettiera</i>
<b>N</b> Without flange <i>Senza flangia</i>  	<b>Flange</b> <i>Flange</i>  	<b>B3</b>  	<b>With coupling</b> <i>Con giunto</i>  	<b>A</b>  
	<b>IEC B14</b> <b>-Q</b> -> 71 B14 (ø105) <b>-R</b> -> 80 B14 (ø120) <b>-T</b> -> 90 B14 (ø140) <b>-U</b> -> 100÷112 B14 (ø160)	<b>B6</b>  	<b>B</b> -> 11mm <b>C</b> -> 14mm <b>D</b> -> 19mm <b>E</b> -> 24mm <b>F</b> -> 28mm	<b>B</b>  
<b>2</b> X42I -> ø175	<b>Without flange</b> <i>Senza flangia</i>	<b>B7</b>  	<b>0</b> Ready for input coupling <i>Predisposto per giunto</i>	<b>C</b>  
<b>3</b> X62I -> ø205	<b>-M</b> With coupling <i>Con giunto</i>  	<b>B8</b>  		<b>D</b>  
		<b>V5</b>  		
		<b>V6</b>  		
		<b>V8</b>  		

# Useful formulas

Formule utili

## Required power - Potenza richiesta

Lifting - Sollevamento

Rotation - Rotazione

Linear movement - Traslazione

$$P_{[kW]} = \frac{M_{[Kg]} \cdot g_{[9.81]} \cdot v_{[m/s]}}{1000}$$

$$P_{[kW]} = \frac{M_{[Nm]} \cdot n_{[rpm]}}{9550}$$

$$P_{[kW]} = \frac{F_{[N]} \cdot v_{[m/s]}}{1000}$$

## Torque - Coppia

$$M_{[Nm]} = \frac{9550 \cdot P_{[kW]}}{n_{[rpm]}}$$

$$M_{[lb\ in]} = \frac{63030 \cdot P_{[HP]}}{n_{[rpm]}}$$

## Radial loads - Carichi radiali

**Radial load generated by external transmissions keyed onto input and/or output shafts.**

Forza radiale generata da organi di trasmissione calettati sugli alberi di ingresso e/o uscita.

$$F_{R[N]} = \frac{M_{[Nm]} \cdot 2000}{d_{[mm]}} \cdot f_k$$

$$F_{R[N]} = \frac{M_{[lb\ in]} \cdot 8.9}{d_{[in]}} \cdot f_k$$

**M:** Output torque - *Momento torcente*

**d:** Diam. of driving element - *Diametro primitivo*

**f<sub>k</sub>:** Factor - *Coefficiente di trasformazione*

**1.15:** Gearwheels - *Ingranaggi*

**1.25:** Chain sprockets - *Catena*

**1.75:** Narrow v-belt pulley - *Cinghia Trapezoidale*

**2.50:** Flat-belt pulley - *Cinghia piatta*



**If your application requires higher radial loads, contact our technical office. Higher loads may be possible.**

Nel caso la vostra applicazione richieda carichi radiali superiori consultare il nostro ufficio tecnico, valori maggiori possono essere accettati.



# How to select a gearbox

Come selezionare un riduttore

## A Select required torque (according to service factor)

Seleziona la coppia desiderata (comprensiva del fattore di servizio)

## B Select output speed

Seleziona la velocità in uscita

## C Select gear ratio in the line corresponding to the chosen motor power

Sulla riga corrispondente alla motorizzazione prescelta si può rilevare il rapporto di riduzione

## D Select motor flange available (if requested)

Scegli la flangia disponibile (se richiesta)

Gear size  
Grandezza  
riduttore

C

Ratio  
Rapporto

Transmitted torque  
Momento torcente  
trasmesso

Nominal power  
Potenza nominale

Flange code  
Codice flangia

Input speed  
Velocità in entrata

X421

150  
Nm



BVI series

Full stainless steel helical bevel gearboxes

Riduttori a coppia conica completamente in acciaio inox

The dynamic efficiency is **0.96** for all ratios

Input speed ( $n_1$ ) = 1400 min<sup>-1</sup>

Output speed $n_2$ [min <sup>-1</sup> ]	Ratio $i$	Motor power $P_{1M}$ [kW]	Output torque $M_{2M}$ [Nm]	Service factor $f.s$	Nominal power $P_{1R}$ [kW]	Nominal torque $M_{2R}$ [Nm]	B5 motor flanges		B14 motor flanges			Output shaft 	Ratio code 
							-	-	Q	-R	-T		
192	<b>7.29</b>	1.5	71	1.3	2.0	95	-	-	71	80	90	2811	01
125	<b>11.20</b>	1.5	110	1.4	2.0	150	-	-	C	C	-	288	02
106	<b>13.18</b>	1.5	129	1.2	1.7	150	-	-	C	C	-	1911	03
92	<b>15.27</b>	1.1	109	1.4	1.5	150	-	-	C	C	-	1711	04
78	<b>17.93</b>	1.1	128	1.2	1.3	150	-	-	C	C	-	1511	05
69	<b>20.25</b>	1.1	145	1.0	1.1	150	-	-	C	C	-	198	06
65	<b>21.40</b>	1.1	153	1.0	1.1	150	-	-	C	C	-	1311	07
60	<b>23.47</b>	0.75	115	1.3	0.98	150	-	-	C	C	-	178	08
51	<b>27.55</b>	0.75	135	1.1	0.83	150	-	-	C	C	-	158	09
...	...	...	...	...	...	...	-	-	...	...	-	...	...

B Output speed  
Velocità in uscita

Motor power  
Potenza motore

Service factor  
Fattore di servizio

A Nominal torque  
Momento torcente  
nominale

Output shaft diam.  
Diametro albero uscita

Notes  
Note

### Type of load and starts per hour

Tipo di carico e avviamenti per ora

Oper. hours per day  
Ore di funz. giorn.

		Oper. hours per day		
		3h	10h	24h
Continuous or intermittent application with start / hour <i>Applicazione continua o intermittente con numero operazioni/ora</i>	Uniform - <i>Uniforme</i>	0.8	1	1.25
	Moderate - <i>Moderato</i>	1	1.25	1.5
	Heavy - <i>Forte</i>	1.25	1.5	1.75
Intermittent application with start / hour <i>Applicazione intermittente con numero operazioni/ora</i>	Uniform - <i>Uniforme</i>	1	1.25	1.5
	Moderate - <i>Moderato</i>	1.25	1.5	1.75
	Heavy - <i>Forte</i>	1.5	1.75	2.15

D Motor flange available  
Flange disponibili

B) Mounting with reduction bushing  
Montaggio con boccia di riduzione 

C) Motor flange holes position/terminal box position  
Posizione fori flangia/basetta motore 

B) Available without reduction bushing  
Disponibile anche senza boccia

# X42I

## 150 Nm

### BVI series

### Full stainless steel helical bevel gearboxes

Riduttori a coppia conica completamente in acciaio inox

The dynamic efficiency is **0.96** for all ratios

Input speed ( $n_1$ ) = 1400 min<sup>-1</sup>

Output speed $n_2$ [min <sup>-1</sup> ]	Ratio $i$	Motor power $P_{1M}$ [kW]	Output torque $M_{2M}$ [Nm]	Service factor $f.s$	Nominal power $P_{1R}$ [kW]	Nominal torque $M_{2R}$ [Nm]	B5 motor flanges		B14 motor flanges			Output shaft 	Ratio code
							-	-	-Q 71	-R 80	-T 90		
192	<b>7.29</b>	1.5	71	1.3	<b>2.0</b>	<b>95</b>	-	-	C	C	-	2811	01
125	<b>11.20</b>	1.5	110	1.4	<b>2.0</b>	<b>150</b>	-	-	C	C	-	288	02
106	<b>13.18</b>	1.5	129	1.2	<b>1.7</b>	<b>150</b>	-	-	C	C	-	1911	03
92	<b>15.27</b>	1.1	109	1.4	<b>1.5</b>	<b>150</b>	-	-	C	C	-	1711	04
78	<b>17.93</b>	1.1	128	1.2	<b>1.3</b>	<b>150</b>	-	-	C	C	-	1511	05
69	<b>20.25</b>	1.1	145	1.0	<b>1.1</b>	<b>150</b>	-	-	C	C	-	198	06
65	<b>21.40</b>	1.1	153	1.0	<b>1.1</b>	<b>150</b>	-	-	C	C	-	1311	07
60	<b>23.47</b>	0.75	115	1.3	<b>0.98</b>	<b>150</b>	-	-	C	C	-	178	08
51	<b>27.55</b>	0.75	135	1.1	<b>0.83</b>	<b>150</b>	-	-	C	C	-	158	09
47.9	<b>29.21</b>	0.75	143	1.0	<b>0.78</b>	<b>150</b>	-	-	C	C	-	1011	10
42.6	<b>32.88</b>	0.75	161	0.9	<b>0.70</b>	<b>150</b>	-	-	C	C	-	138	11
36.7	<b>38.12</b>	0.55	138	1.1	<b>0.60</b>	<b>150</b>	-	-	C	C	-	911	12
31.2	<b>44.89</b>	0.55	163	0.9	<b>0.51</b>	<b>150</b>	-	-	C	C	-	108	13
27.8	<b>50.34</b>	0.37	122	1.1	<b>0.40</b>	<b>131</b>	-	-	C	C	-	711	14
23.9	<b>58.58</b>	0.37	142	1.1	<b>0.39</b>	<b>150</b>	-	-	C	C	-	98	15
18.1	<b>77.36</b>	0.25	126	1.2	<b>0.30</b>	<b>150</b>	-	-	C	C	-	78	16

Motor flanges available  
Flange motore disponibili

 B) Supplied with reduction bushing  
Fornito con bussola di riduzione

B) Available on request without reduction bushing  
Disponibile a richiesta senza bussola di riduzione

 C) Motor flange holes position  
Posizione fori flangia motore

## Lubrication

Lubrificazione

Unit X42I is supplied with synthetic oil to assure long life lubrication. Food grade oil is available on request.

See Table 1 for lubrication and recommended quantity.



See Table 2 for possible radial and axial loads on the gearbox.

Il riduttore tipo X42I viene fornito con olio sintetico e lubrificazione tipo "long life".

Disponibile a richiesta olio alimentare.

Vedi Tabella 1 per oli e quantità consigliati.

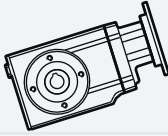
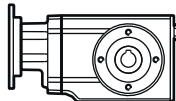
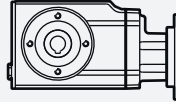
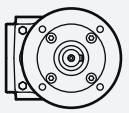
Vedi Tabella 2 per i carichi radiali e assiali applicabili al riduttore.

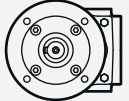
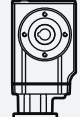
<b>Agip</b> Telium VSF 320	<b>Shell</b> Omala S4 WE 320	<b>V8</b> On request ASK	
<b>B3</b> Standard 0.85 LT		<b>B8</b> On request 1.00 LT	
<b>B6</b> On request 0.95 LT		<b>V5</b> On request 1.60 LT	
<b>B7</b> On request 0.85 LT		<b>V6</b> On request 1.00 LT	

For more details on lubrication and plugs check our website.

Per maggiori dettagli su lubrificazione e tappi olio vedi il nostro sito web.

Tab. 1

## Radial and axial loads

Carichi radiali e assiali

### Output shaft

Albero di uscita

$n_2$ [min <sup>-1</sup> ]	$F_A$ [N]	$F_R$ [N]
250	500	2500
150	600	3000
100	700	3500
75	800	4000
50	960	4800
25	960	4800
15	960	4800

$$F_{eq} = F_R \cdot \frac{54}{X + 28}$$

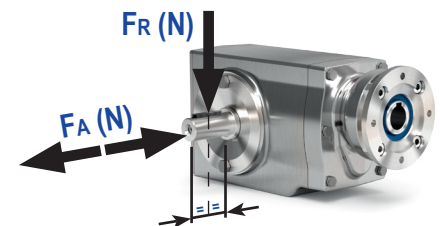
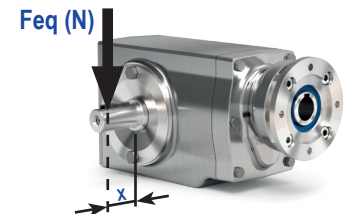

Tab. 2

150  
Nm

X421

PX421I...

**Basic gearbox**  
*Riduttore base*

**Gearbox weight**  
*peso riduttore* **13.0 kg**

M. flanges	Kit code	øF	A
71B14	KI634047	105	197.5
80B14	KI634046	120	199.5
90B14	KI634041	140	199.5

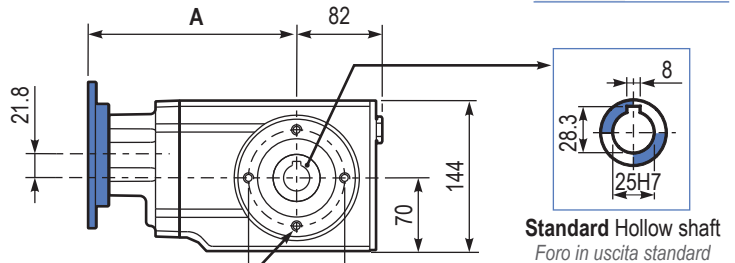
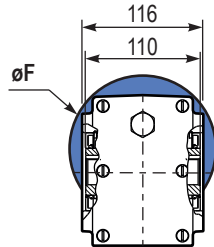

**Standard Hollow shaft**  
*Foro in uscita standard*

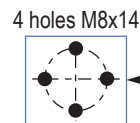

**Mounting holes position**  
*Posizione fori di montaggio*

PX421-FB..

**Feet**  
*Piedini*

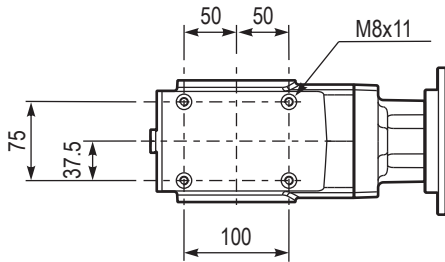

PX421-FL..

**Output flange**  
*Flangia uscita*

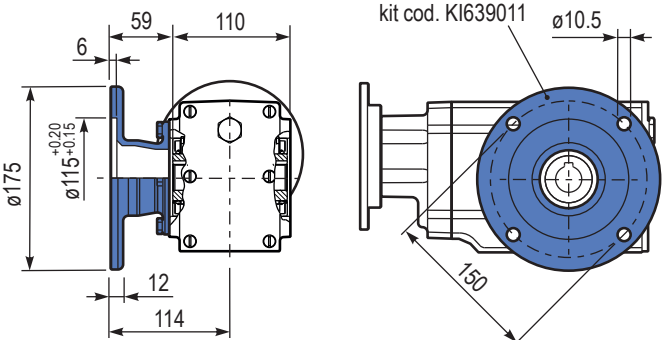

PX421..A..

**Single output shaft**  
*Albero semplice in uscita*

kit cod. KI630211

**Protection cap (on request)**

*A richiesta coperchio di protezione*

kit cod. KX4I5028

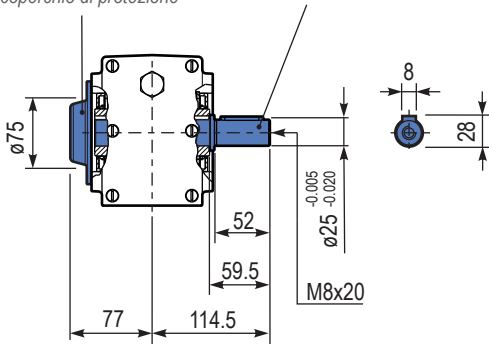

PX421BR..

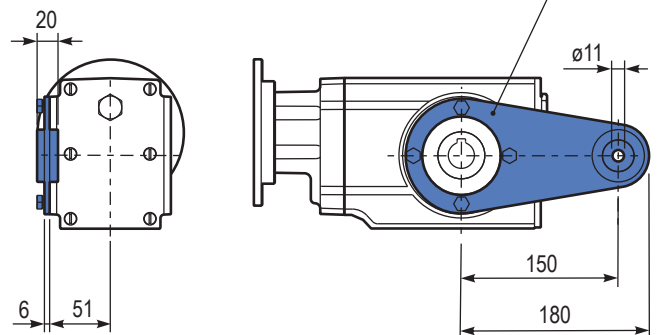

**Reaction Arm**  
*Braccio di reazione*

kit cod. KX4I9027



The dynamic efficiency is **0.96** for all ratios

Input speed ( $n_1$ ) = 1400 min<sup>-1</sup>

Output speed $n_2$ [min <sup>-1</sup> ]	Ratio $i$	Motor power $P_{1M}$ [kW]	Output torque $M_{2M}$ [Nm]	Service factor $f_s$	Nominal power $P_{1R}$ [kW]	Nominal torque $M_{2R}$ [Nm]	B5 motor flanges				B14 motor flanges			Output shaft 	Ratio code 
							-	-	-	-	-R	-T	-U		
232	6.03	4	155	1.6	6.1	240								3011	01
151	9.26	4	238	1.1	4.5	270								308	02
123	11.36	4	291	1.2	4.7	350								2011	03
91	15.36	4	394	1.0	3.8	385								1611	04
80	17.46	4	448	0.9	3.5	400								208	05
70	19.97	3	386	1.1	3.1	410								1311	06
59	23.60	3	456	0.9	2.7	410								168	07
57	24.45	3	472	0.9	2.6	410								1111	08
45.6	30.69	2.2	436	0.9	2.0	410								138	09
39.6	35.35	1.5	346	1.2	1.8	410								811	10
37.3	37.57	1.5	368	1.1	1.7	410								118	11
28.8	48.68	1.1	348	1.0	1.1	365								611	12
25.8	54.33	1.1	389	1.1	1.2	410								88	13
18.7	74.81	0.75	367	1.0	0.73	360								68	14

Motor flanges available  
Flange motore disponibili

 B) Supplied with reduction bushing  
Fornito con Bussola di Riduzione

B) Available on request without reduction bushing  
Disponibile a Richiesta senza Bussola di Riduzione

 C) Motor flange holes position  
Posizione Fori Flangia Motore

### Lubrication

Lubrificazione

Unit X621 is supplied with synthetic oil to assure long life lubrication. Food grade oil is available on request.

See Table 1 for lubrication and recommended quantity.

See Table 2 for possible radial and axial loads on the gearbox.

Il riduttore tipo X621 viene fornito con olio sintetico e lubrificazione tipo "long life".

Disponibile a richiesta olio alimentare.

Vedi Tabella 1 per oli e quantità consigliati.

Vedi Tabella 2 per i carichi radiali e assiali applicabili al riduttore.

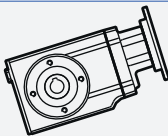
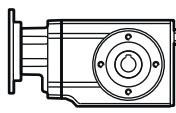
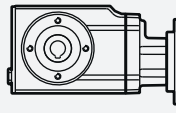
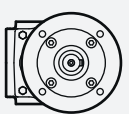
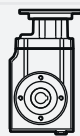
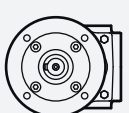
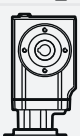
<b>Agip</b> Telium VSF 320	<b>Shell</b> Omala S4 WE 320	<b>V8</b> On request ASK	
<b>B3</b> Standard 1.85 LT		<b>B8</b> On request 2.00 LT	
<b>B6</b> On request 2.00 LT		<b>V5</b> On request 3.35 LT	
<b>B7</b> On request 1.70 LT		<b>V6</b> On request 2.30 LT	

For more details on lubrication and plugs check our website.

Per maggiori dettagli su lubrificazione e tappi olio vedi il nostro sito web.

### Radial and axial loads

Carichi radiali e assiali

#### Output shaft

Albero di uscita

$n_2$ [min <sup>-1</sup> ]	$F_A$ [N]	$F_R$ [N]
250	600	3000
150	700	3500
100	780	3900
75	890	4450
50	1140	5700
25	1330	6650
15	1660	8300

$$F_{eq} = F_R \cdot \frac{69}{X + 39}$$

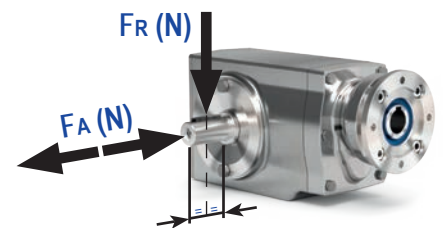
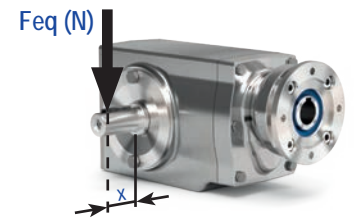

410  
Nm

X621

**PX621I...** Basic gearbox  
*Riduttore base*

Gearbox weight  
*peso riduttore* 25.8 kg

M. flanges	Kit code	øF	A
80B14	KI854046	120	255
90B14	KI854045	140	255
100-112B14	KI854041	160	264

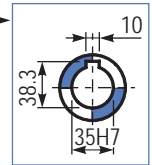
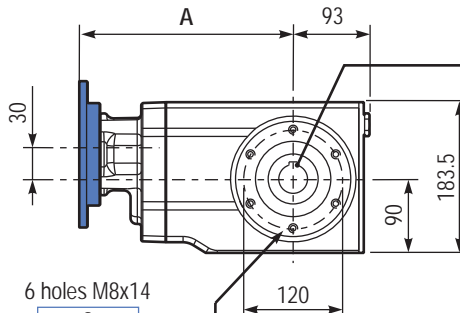
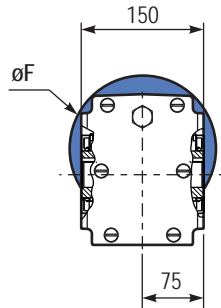

Standard Hollow shaft  
*Foro in uscita standard*

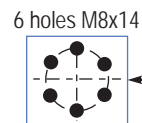

6 holes M8x14  
Mounting holes position  
*Posizione fori di montaggio*

**PX621-FB..** Feet  
*Piedini*

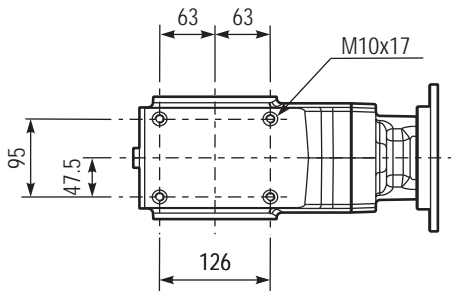

**PX621-FL..** Output flange  
*Flangia uscita*

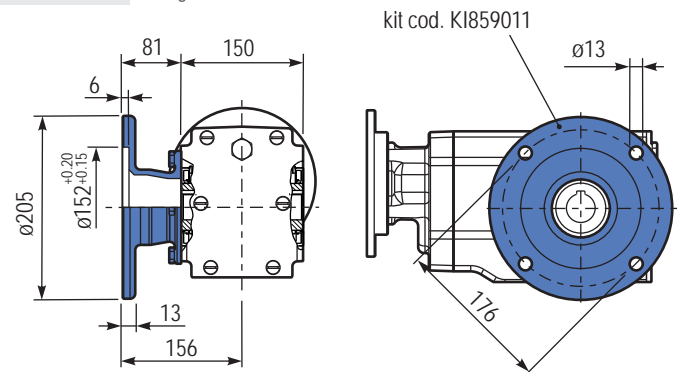

**PX621..A..** Single output shaft  
*Albero semplice in uscita*

kit cod. KI850211  
Protection cap  
(on request)

*A richiesta coperchio di protezione*

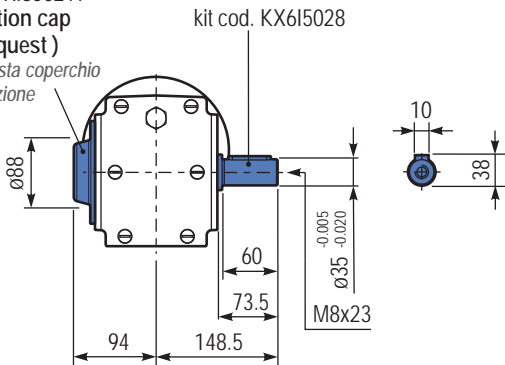

**PX621BR..** Reaction Arm  
*Braccio di reazione*

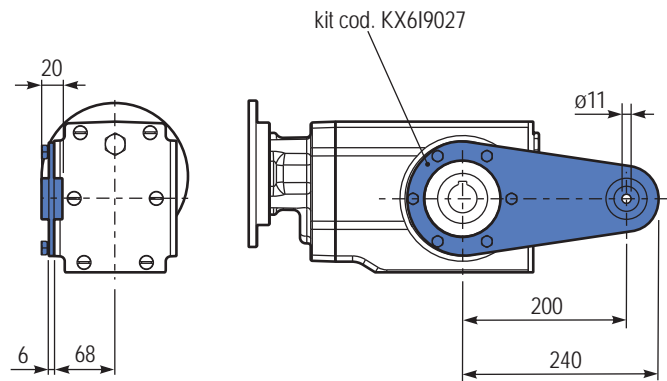

# Electric motors

# APM series Aluminum premium electric motors

*Motori elettrici in alluminio*

Section **AM**  
Sezione AM



Sizes: IEC 63..90L, 4 poles  
Voltage:  $\Delta/Y$  230/400V - 50Hz  
Protection: I.Cl.F - IP69k - IC410  
Efficiency: IE3 (IEC60034-30, IEC60034-2-1,  $P_n \geq 0,75kW$ )  
Duty cycle: S1  
Other features: INVERTER DUTY, HYGIENIC, PTO PROTECTION INCLUDED



# FEATURES

Caratteristiche

## APM series Aluminum premium electric motors

*Motori elettrici in alluminio*

**Electrical motors of the APM series have no cooling fins and are treated with the innovative “Hi-Cleaning” coating applying nano particles (patented system), which makes the surface very easy to clean and resistant to major aggressive agents used in sanitizing.**

*La gamma APM non ha alette di raffreddamento ed è trattata con un innovativo rivestimento «Hi-Cleaning» alle nano particelle (sistema brevettato) che rende la superficie estremamente facile da pulire e resistente ai principali agenti aggressivi usati nella sanificazione.*

**All external components are manufactured in aluminium while motor shaft is produced in 420 stainless steel with magnetic properties and all screws are made of 316L stainless steel.**

*Tutti i componenti esterni sono realizzati in alluminio, l'albero motore è in acciaio AISI420 con proprietà magnetiche, tutte le viterie in AISI316L.*

**Standard plastic Hygienic cable gland.**

*Pressacavo “igienico” standard in plastica.*

**Product label on the back cover**

*Etichetta sul coperchio posteriore.*

**Easy connection with Wire-to-Wire heat-shrinkable splicings.**

*L' utilizzo di connettori testa-testa termo-sigillanti rende semplice il collegamento dei cavi.*



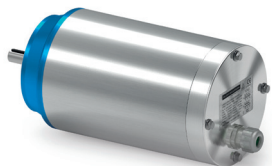

**Totally enclosed and non-ventilated (IC410) design along with completely smooth surfaces ensures the highest hygienic standards.**

*Totamente chiuso, non ventilato (IC410), le superfici completamente lisce garantiscono gli standard di igienicità più elevati richiesti dal mercato.*

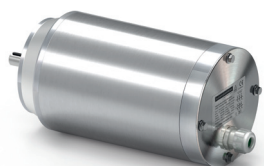

**The surface temperature is rather low thanks to an accurate electromagnetic design and additional internal active material. The efficiency class is IE3.**

*La temperatura di superficie è contenuta grazie ad una progettazione accurata. La classe di efficienza è IE3 ( $\geq 0.75kW$ ).*

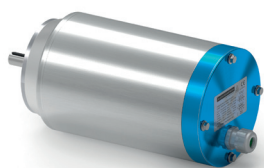

**Pipe housing without weldings and terminal box on the NDE enhance the impact of an eye-catching design.**

*Carcassa tubolare senza saldature, coprimorsettiera posteriore e look accattivante.*

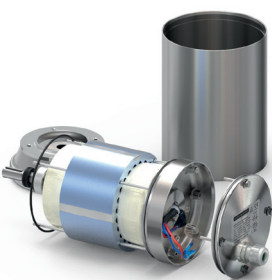

**Motors are suitable for INVERTER DUTY OPERATION with large range at constant torque, thanks to low loss laminations, vacuum impregnation of the windings and inverter duty magnet wires. Stator and rotor are coated with anti-oxidant painting.**

*I motori sono idonei al funzionamento con INVERTER con ampio range a coppia costante, grazie a lamiere a basse perdite e all'impregnazione degli avvolgimenti sottovuoto. Statore e rotore sono rivestiti con vernice antiossidante.*

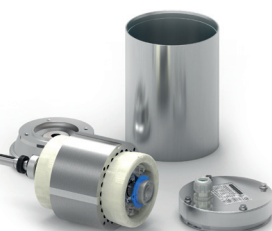

**NDE bearing is axially locked. Precise mechanical execution.**

*Cuscinetto posteriore bloccato assialmente, esecuzione meccanica precisa.*

### B14

### Dimensions Dimensioni

#### 63A÷90L

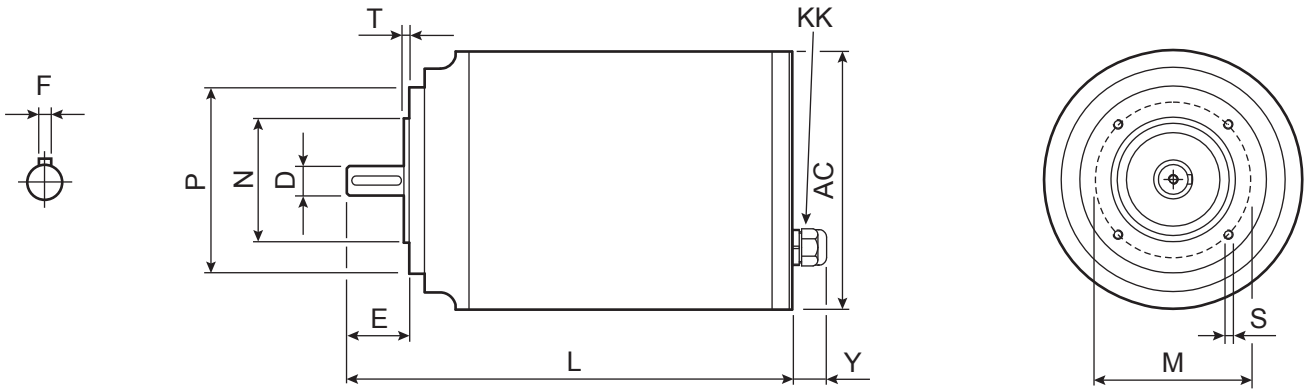

Sizes: IEC 63..90L, 4 poles  
Voltage:  $\Delta/Y$  230/400V - 50Hz  
Protection: I.C.I.F - IP69k - IC410  
Efficiency: IE3 (IEC60034-30, IEC60034-2-1,  $P_n \geq 0,75kW$ )  
Duty cycle: S1  
Other features: INVERTER DUTY, HYGIENIC, PTO PROTECTION INCLUDED

#### 4 poles B14

Motor	kW	IE3	rpm (min <sup>-1</sup> )	Nm	A (400V)	COS ( $\phi$ )	D	F	E	L	AC	Y	N	M	P	T	S	Kg	KK
63A	0.12		1440	0.80	0.44	0.57	11 j6	4	23	229	131	24	60 j6	75	90	2.5	4xM5	6.9	M16x1.5 ø4-8 Tightening: 2 Nm
63B	0.18			1.19	0.58	0.62	M4											8.0	
71A	0.25		1440	1.66	0.72	0.64	14 j6	5	30	266	131	27	70 j6	85	105	2.5	4xM6	9.4	M20x1.5 ø6-12 Tightening: 3 Nm
71B	0.37			2.45	1.10	M5	11.1												
80A	0.55		1460	3.60	1.50	0.67	19 j6	6	40	280	166		80 j6	100	120	3	4xM6	15.3	M25x1.5 ø13-18 Tightening: 4 Nm
80B	0.75			4.91	2.10	M6	18.0												
90S	1.1		1460	7.20	2.90	0.70	24 j6	8	50	345	166	30	95 j6	115	140	3	4xM8	22.7	M25x1.5 ø13-18 Tightening: 4 Nm
90L	1.5			9.81	4.00	M8	28.4												

# SPM series Stainless steel premium electric motors

*Motori elettrici in acciaio inox*

Section **SM**  
Sezione SM



Sizes: IEC 63..100LA, 4 poles

Voltage:  $\Delta/Y$  230/400V - 50Hz

Protection: I.C.I.F - IP69k - IC410

Efficiency: IE3 (IEC60034-30, IEC60034-2-1,  $P_n \geq 0,75kW$ )

Duty cycle: S1

Other features: INVERTER DUTY, HYGIENIC, PTO PROTECTION INCLUDED

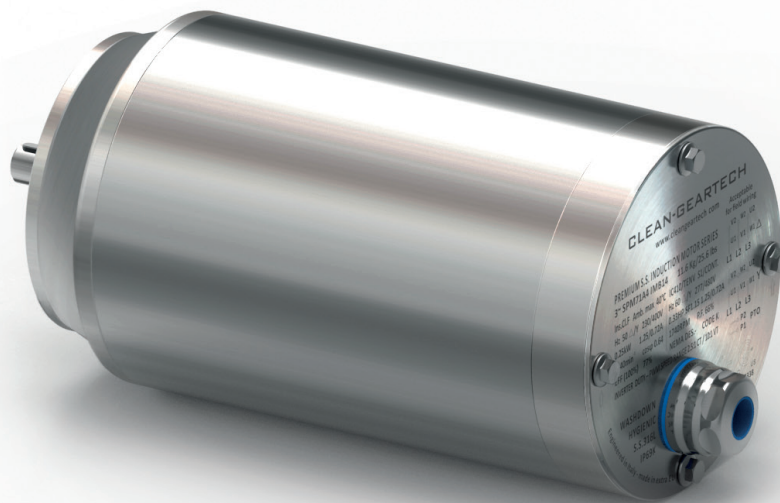

# FEATURES

Caratteristiche

## SPM series Stainless steel premium electric motors

*Motori elettrici in acciaio inox*

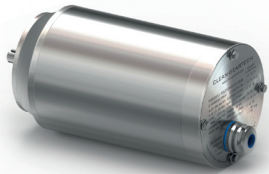

All external components are manufactured in AISI 316L stainless steel while motor shaft is made of 420 stainless steel with magnetic properties. Completely smooth surfaces with nothing to break off and excellent resistance to corrosion represent a reliable and durable solution for numerous applications where hygiene and cleanliness are essential.

*Tutti i componenti esterni sono realizzati in acciaio inox AISI 316L, l'albero motore è in acciaio inox 420 con proprietà magnetiche. Tutte le superfici sono completamente lisce. Questo dà eccellente resistenza alla corrosione e una soluzione affidabile e duratura laddove l'igiene è fondamentale.*



**Stainless steel Hygienic cable gland certified EHEDG.**

*Pressacavo in acciaio inox, con design igienico, certificato EHEDG.*

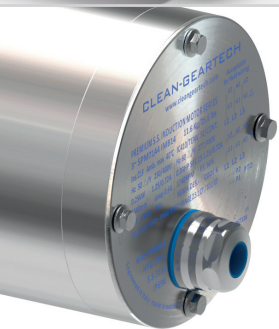

**Product label is laser engraved.**

*Targhettatura laser sul coperchio posteriore.*



**IP69K is guaranteed by Viton oil seals and O-rings.**

*Anelli di tenuta e O-Rings in Viton garantiscono un grado di protezione IP69K.*



**Easy connection with Wire-to-Wire heat-shrinkable splicings.**

*L' utilizzo di connettori testa-testa termo-sigillanti rende semplice il collegamento dei cavi.*

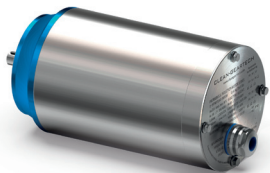

**Totally enclosed and non-ventilated (IC410) design along with completely smooth surfaces ensures the highest hygienic standards.**

*Totamente chiuso non ventilato (IC410), le superfici completamente lisce garantiscono gli standard di igienicità più elevati richiesti dal mercato.*



**The surface temperature is rather low thanks to an accurate electromagnetic design and additional internal active material. The efficiency class is IE3.**

*La temperatura di superficie è contenuta grazie ad una progettazione accurata. La classe di efficienza è IE3 ( $\geq 0.75kW$ ).*

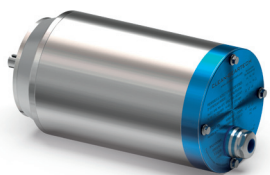

**Pipe housing without weldings and terminal box on the NDE enhance the impact of an eye-catching design.**

*Carcassa tubolare senza saldature, coprimorsettiera posteriore e look accattivante.*

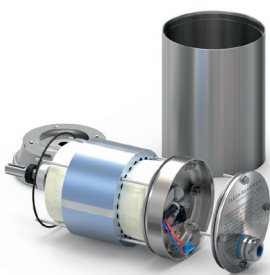

**Motors are suitable for INVERTER DUTY OPERATION with large range at constant torque, thanks to low loss laminations, vacuum impregnation of the windings and inverter duty magnet wires. Stator and rotor are coated with anti-oxidant painting.**

*I motori sono idonei al funzionamento con INVERTER con ampio range a coppia costante, grazie a lamierini a basse perdite e all'impregnazione degli avvolgimenti sottovuoto. Statore e rotore sono rivestiti con vernice antiossidante.*



**NDE bearing is axially locked. Precise mechanical execution.**

*Cuscinetto posteriore bloccato assialmente, esecuzione meccanica precisa.*

### B14

### Dimensions

Dimensioni

63A÷90L (Totally enclosed, not ventilated)

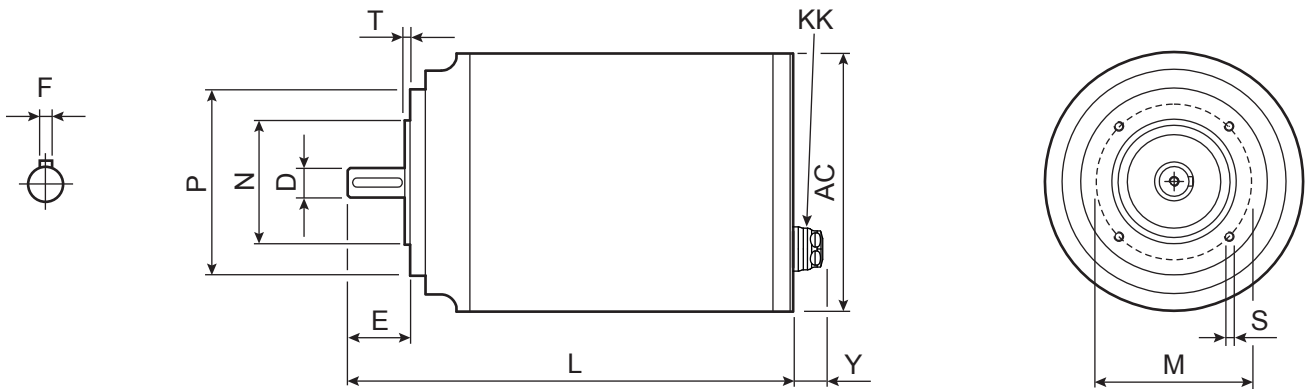

100LA (Ventilated)

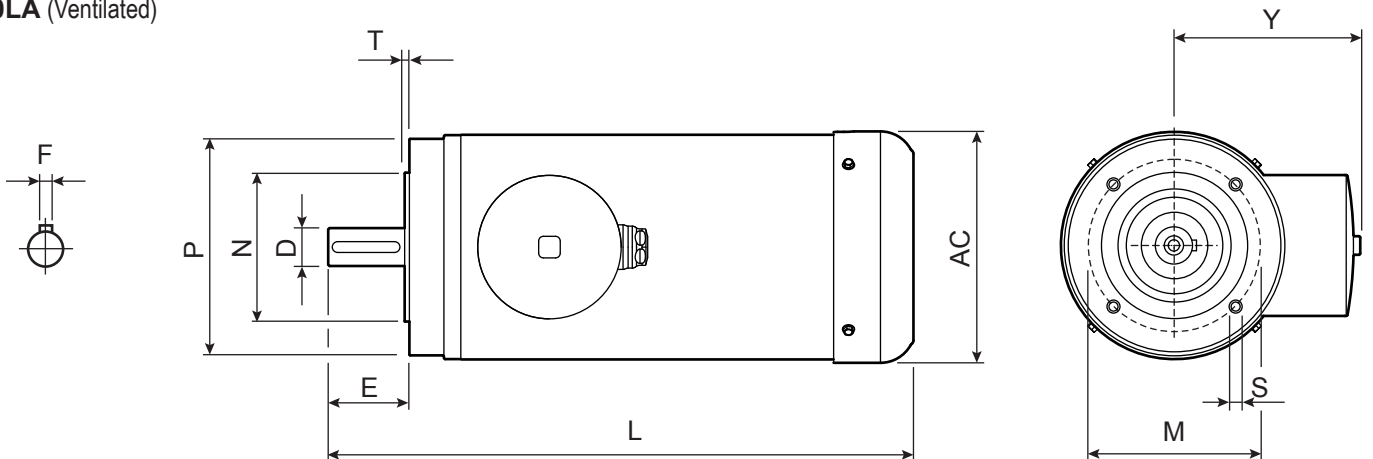

4 poles B14

Motor	kW	IE3	rpm (min <sup>-1</sup> )	Nm	A (400V)	COS (φ)	D	F	E	L	AC	Y	N	M	P	T	S	Kg	KK
63A	0.12		1440	0.80	0.44	0.57	11 j6	4	23	229	131	24	60 j6	75	90	2.5	4xM5	8.7	M16x1.5 ø7.5-10 Tightening: 15 Nm
63B	0.18		1440	1.19	0.58	0.62	M4			244								10.0	
71A	0.25		1440	1.66	0.72	0.64	14 j6	5	30	266	131	27	70 j6	85	105	2.5	4xM6	11.6	M20x1.5 ø11-13.5
71B	0.37		1440	2.45	1.10		M5			286								13.5	
80A	0.55		1460	3.60	1.50	0.67	19 j6	6	40	280	166		80 j6	100	120	3	4xM6	19.0	Tightening: 18 Nm
80B	0.75		1460	4.91	2.10		M6			305								22.0	
90S	1.1		1460	7.20	2.90	0.70	24 j6	8	50	345	166	30	95 j6	115	140	3	4xM8	27.0	M25x1.5 ø11-13.5 Tightening: 35 Nm
90L	1.5		1460	9.81	4.00		M8			390								33.0	
100LA	2.2		1440	14.6	4.80	0.79	28 j6	8	60	432.5	171	140	110 j6	130	160	3.5	4xM8	34.0	M20x1.5 ø11-13.5 Tightening: 18 Nm

Ventilated

# IEC B5 only on request

Sizes: IEC 63..100LA, 4 poles  
 Voltage:  $\Delta/Y$  230/400V - 50Hz  
 Protection: I.C.I.F - IP69k - IC410  
 Efficiency: IE3 (IEC60034-30, IEC60034-2-1,  $P_n \geq 0,75kW$ )  
 Duty cycle: S1  
 Other features: INVERTER DUTY, HYGIENIC, PTO PROTECTION INCLUDED

**B5**

## Dimensions

*Dimensioni*

**63A÷90L** (Totally enclosed, not ventilated)

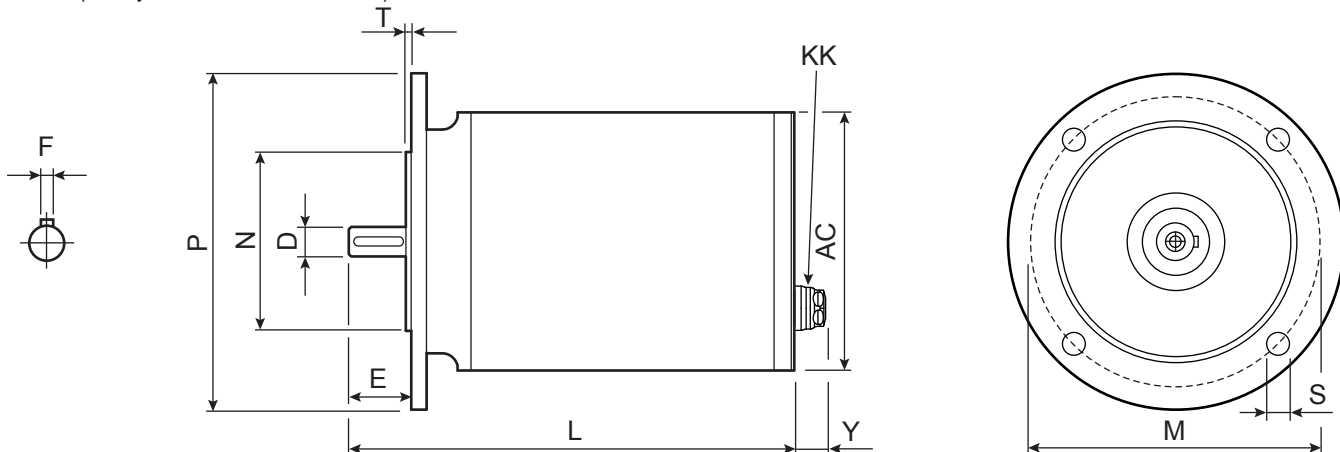

**100LA** (Ventilated)

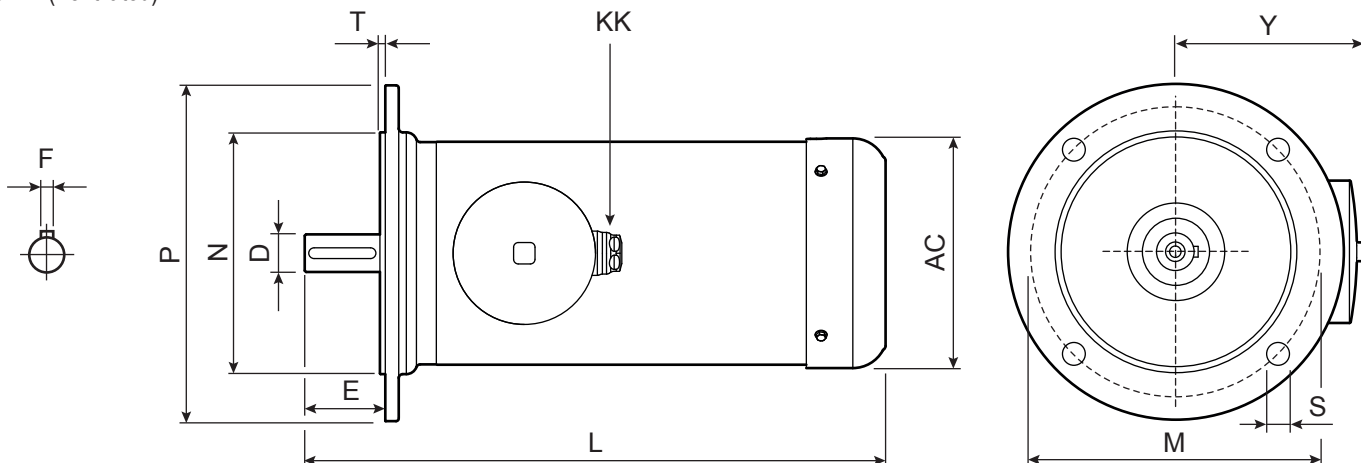

4 poles B5

Motor	kW	IE3	rpm (min <sup>-1</sup> )	Nm	A (400V)	COS (φ)	D	F	E	L	AC	Y	N	M	P	T	S	Kg	KK
63A	0.12		1440	0.80	0.44	0.57	11 j6	4	23	229	131	24	95 j6	115	140	3	4x10	9.4	M16x1.5 ø7.5-10 Tightening: 15 Nm
63B	0.18			1.19	0.58	0.62	M4			244								10.7	
71A	0.25		1440	1.66	0.72	0.64	14 j6	5	30	266	131	27	110 j6	130	160	3.5	4x10	12.5	M20x1.5 ø11-13.5 Tightening: 18 Nm
71B	0.37			2.45	1.10	0.67	M5		40	286			130 j6	165	200	3.5	4x12	14.4	
80A	0.55		1460	3.60	1.50	0.67	19 j6	6	40	280	166	30	130 j6	165	200	3.5	4x12	21.0	Tightening: 18 Nm
80B	0.75			4.91	2.10	0.70	M6		50	305			130 j6	165	200	3.5	4x12	24.0	
90S	1.1		1460	7.20	2.90	0.70	24 j6	8	50	345	166	30	130 j6	165	200	3.5	4x12	28.5	M25x1.5 ø15-18 Tightening: 35 Nm
90L	1.5			9.81	4.00	0.79	M8		60	390			130 j6	165	200	3.5	4x12	34.5	
100LA	2.2			14.6	4.80	0.79	28 j6	8	60	432.5	171	140	180 j6	215	250	4	4x15	36.0	M20x1.5 ø11-13.5 Tightening: 18 Nm

Ventilated



**IP69k is a rating of German standard DIN 40050-9 extending the IEC 60529 that provides the maximum protection degree against close range high pressure (100 bar), high temperature (80°C) spray downs, applied at a variety of angles, as well as against dust penetration. In many industries, where dust and dirt can be an issue or where hygiene and cleanliness are essential, like in food and beverage industry, this certification is indispensable for the equipment that must be sanitized, withstanding rigorous high pressure and high temperature wash-down procedures.**

*Il codice IP indica il grado di protezione del prodotto contro l'intrusione di particelle solide e di liquidi. IP69K è il massimo grado di protezione: contro la penetrazione della polvere e dei getti d'acqua/vapore ad alta pressione (100 bar) ed alta temperatura (80°C), da angolazioni differenti.*

*In molte industrie dove la polvere e la sporcizia possono essere un problema oppure dove l'igiene e la pulizia sono essenziali, come nell'industria alimentare, questa certificazione è indispensabile per la sanitizzazione dell'apparecchiatura, in grado di sopportare le procedure di lavaggio ad alta pressione e temperatura.*



**Products marked cCSAus are certified to be manufactured in accordance with the requirements of Canadian CSA and American UL and approved to be used in Canada and USA. This certification means that the products were tested and resulted compliant regarding potential flammability, electrical shock and mechanical hazard.**

*I prodotti marchiati cCSAus hanno la certificazione di essere stati costruiti in accordo ai requisiti della CSA Canadese e UL Americana, sono approvati per l'uso in Canada e Stati Uniti. Significa che sono stati testati e risultano idonei, in relazione ai loro potenziali rischi di incendio, shock elettrico e pericoli meccanici.*



**NTT™ stands for a special treatment which results in modified external properties of the mechanical parts with complex geometry. It is a highly technological process which benefits from the expertise in many industrial and scientific fields. An excellent resistance to corrosion and long durability are the main features of NTT™ finishing, which makes NTT™ treated products a first choice and unique solution for variety of applications in many industries.**

*NTT™ è uno speciale trattamento che come risultato ha la modifica delle proprietà superficiali delle parti meccaniche con geometria complessa. E' un processo altamente tecnologico che trae benefici dalle competenze in vari campi sia industriali che scientifici. Ottima resistenza alla corrosione e durabilità sono le caratteristiche principali della finitura NTT™ che fa del trattamento la soluzione unica e di prima scelta per la molteplicità delle applicazioni in numerosi settori industriali.*



**By applying CE mark a manufacture declares the conformity of the product to the safety requirements settled in European regulations. It means that the product is compliant to all the directives of European Community regarding its usage: from design and manufacturing to release to the market, functioning and recycling.**

*Mediante l'applicazione della marcatura CE al prodotto, si dichiara alle autorità che esso è conforme ai requisiti di sicurezza previsti dalle norme Europee.*

*La marcatura CE indica che il prodotto è conforme a tutte le disposizioni della Comunità Europea che prevedono il suo utilizzo: dalla progettazione, alla fabbricazione, all'immissione sul mercato, alla messa in servizio del prodotto fino allo smaltimento.*





**IE mark indicates the efficiency class for electrical motor (Standard IEC 60034-30:2008 for three-phase low tension motors) “IE” code stands for “International Efficiency”: IE1 = Standard Efficiency; IE2 = High Efficiency; IE3 = Premium Efficiency.**

**Starting from the 1st January 2017 IE3 efficiency is mandatory for the motors between 0,75 and 375 kW and IE2 in case the motor powered by inverter.**

*Con la sigla IE si definisce la classe di rendimento del motore elettrico (Norma IEC 60034-30:2008, per motori trifase a bassa tensione). Il Codice “IE” sta per “Efficienza Internazionale”: IE1 = Rendimento Standard; IE2 = Rendimento Elevato; IE3 = Rendimento Premium. Dall’1 Gennaio 2017 i motori con potenza da 0,75 a 375 kW dovranno avere efficienza IE3, o IE2 nel caso il motore sia alimentato da inverter.*



**ATEX abbreviation, which stands for French “Atmosphere Explosible”, identifies the Directive 2014/34/UE that replaced the previous 94/9/CE. The field of application of ATEX Directive extends to all equipment exploited in a potentially explosive environment on the territory of European Union. ATEX Directive appoints the notified European bodies (CESI, TÜV, KEMA, INERIS, Nemko, etc.) qualified for examination and verification of technical documentation, special testing and filing of relative documentation; once this procedure terminated successfully a manufacture is authorized to declare the conformity of its products to ATEX and use the ATEX mark on them.**

*Con ATEX si identifica la Direttiva 2014/34/UE, che ha sostituito la precedente 94/9/CE (il nome deriva dalla contrazione delle parole francesi “Atmosphere Explosible”). Il campo di applicazione della Direttiva ATEX comprende tutti gli apparecchi che devono essere installati, all’interno della Unione Europea, in ambienti potenzialmente a rischio di esplosione. La Direttiva ATEX stabilisce gli organismi europei notificati in EU (CESI, TÜV, KEMA, INERIS, Nemko, etc.) abilitati all’esame e verifica della documentazione tecnica, esecuzione di test specifici ed archiviazione della relativa documentazione; la procedura a seguito della quale, il produttore è autorizzato a rilasciare la dichiarazione di conformità dei propri prodotti alla normativa ATEX e l’utilizzo del marchio ATEX su di essi.*



**NSF International is an accredited, independent third-party certification organization that tests and certifies products to verify they meet these public health and safety standards. The NSF certification mark on a product means that the product complies with all standard requirements referring to the hygienic and health. NSF conducts periodic unannounced inspections and product testing to verify that the product continues to comply with the standard.**

*NSF International è un’organizzazione indipendente accreditata di certificazione che testa e certifica i prodotti per verificare che essi garantiscano i requisiti delle norme di Salute e Sicurezza. Il marchio NSF su un prodotto significa che il prodotto stesso è conforme agli standard richiesti in riferimento alle norme di igiene e salute. NSF esegue controlli periodici non annunciati per verificare che il prodotto continui ad essere conforme agli standard delle norme.*

**SINCE CLEAN-GEARTECH IS A DIVISION OF HYDRO-MEC SPA,  
HYDROMECS SPA IS THE LEGAL RESPONSABLE FOR WARRANTY ISSUES.**

#### PLEASE READ CAREFULLY

The following WARNING and CAUTION information are supplied to you for the proper functioning of your product.

Read ALL instructions prior to operating reducer.

Injury to personnel or reducer failure may be caused by improper installation, maintenance or operation.

#### WARNING:

- Written authorization is required to operate or use reducers in man lift or people moving devices.
  - Check to make sure that certain applications do not exceed the allowable load capacities published in the current catalog.
  - Buyer shall be solely responsible for determining the adequacy of the product for any and all uses to which Buyer shall apply the product. The application by Buyer shall not be subject to any implied warranty of fitness for a particular purpose.
  - For safety, Buyer or User should provide protective guards over all shaft extensions and any moving apparatus mounted thereon. The User is responsible for checking all applicable safety codes in his area and providing suitable guards. Failure to do so may result in bodily injury and/or damage to equipment.
  - Gearboxes operating in high position should have a protective shield for any possible parts falling down for casual accidents where people are moving under them.
  - Hot oil and reducers can cause severe burns. Use extreme care when removing lubrication plugs and vents.
  - Make certain that the power supply is disconnected before attempting to service or remove any components. Lock out the power supply and tag it to prevent unexpected application power.
  - Reducers are not to be considered fail safe or self-locking devices. If these features are required, a properly sized, independent holding device should be utilized.
- Reducers should not be used as a brake.
- Any brakes that are used in conjunction with a reducer must be sized or positioned in such a way so as to not subject the reducer to loads beyond the catalog rating.
  - Lifting supports including eyebolts are to be used for vertically lifting the gearbox only and not other associated attachments or motors.
  - Use of an oil with an EP additive on units with backstops may prevent proper operation of the backstop. Injury to personnel, damage to the reducer or other equipment may result.
  - Overhung loads subject shaft bearings and shafts to stress which may cause premature bearing failure and or shaft breakage from bending fatigue, if not sized properly.

#### SELLING CONDITIONS

Warranty for manufacturing defects will expire one-year after the invoicing date. Cleangeartech will replace or repair defective parts but will not accept any further changes for direct or indirect damages of any kind. The warranty will become null and void if repairs or changes are carried out without our prior written authorization.

**Our company will not be responsible for any direct or indirect damages, caused by a wrong use of the products or for not observing the catalogue/web indication.**

**If the process requires total protections the customers should consider additional measures to avoid any contaminations arising from the gearboxes.**

**CLEAN-GEARTECH È UNA DIVISIONE DI HYDRO-MEC SPA PER QUESTO MOTIVO HYDROMECS SPA È LEGALMENTE IL RESPONSABILE DEI PROBLEMI DI GARANZIA**

#### LEGGERE ATTENTAMENTE

Le seguenti raccomandazioni sono fondamentali per un buon funzionamento del vostro prodotto.

Leggere attentamente tutte le istruzioni prima di azionare il riduttore.

L'inappropriata installazione, manutenzione o funzionamento del riduttore può causare incidenti al personale addetto edanni al riduttore stesso.

#### ATTENZIONE:

- E' richiesta autorizzazione scritta per azionare riduttori in ascensori o dispositivi per il movimento delle persone.
- Controllare che alcune applicazioni non eccedano la massima capacità di carico ammessa pubblicata in questo catalogo.
- L'acquirente è l'unico responsabile per la determinazione dell'adeguatezza del prodotto per qualcuna o tutte le utilizzazioni che l'acquirente stesso farà del riduttore. L'applicazione dell'acquirente non potrà essere soggetta ad alcuna implicita garanzia di montaggio per uno scopo particolare.
- Per ragioni di sicurezza l'acquirente dovrà provvedere a porre protezioni adeguate su tutta la lunghezza dell'albero a tutti gli organi in movimento. L'utilizzatore è responsabile del controllo di tutti i codici di sicurezza e la predisposizione di protezioni adeguate. In assenza di tali precauzioni si possono verificare incidenti alle persone e danni agli apparati.
- Su riduttori installati in posizioni elevate utilizzare protezioni adeguate per qualsiasi distacco accidentale di parti nel caso di passaggio di persone al di sotto.
- Olio e riduttori bollenti possono causare gravi ustioni. Usare estrema cautela nella rimozione dei tappi e delle ventole.
- Assicurarsi che la corrente di alimentazione sia scollegata prima di riparare o rimuovere alcun componente. Chiudere l'alimentazione e contrassegnare tale operazione per evitare accensioni accidentali.
- I riduttori non devono essere considerati esenti da guasti o a bloccaggio automatico. Se sono indispensabili queste caratteristiche, deve essere utilizzato un dispositivo indipendente della dimensione adatta. I riduttori non devono essere utilizzati come freni.
- Qualsiasi freno sia utilizzato insieme al riduttore deve essere della giusta grandezza e posizionato in modo da non causare carichi eccessivi non previsti dai dati forniti nel catalogo.
- I dispositivi di sollevamento come le golfare devono essere usati solo per sollevare verticalmente il riduttore e non altri dispositivi associati o motori.
- L'utilizzo di un olio con un additivo EP su gruppi provvisti di dispositivo di arresto possono inficiare l'uso corretto del freno e provocare danni alle persone, alle cose ed al riduttore stesso nonché ad altri apparecchi.
- I Carichi sospesi assoggettano i cuscinetti della vite e la vite stessa a sollecitazioni che possono causare, se non adeguatamente dimensionati, l'usura prematura dei cuscinetti e/o l'arottura della vite a causa della resistenza alla flessione.

#### CONDIZIONI DI VENDITA

La garanzia relativa a difetti di costruzione ha la durata di un anno dalla data di fatturazione della merce. Tale garanzia comporta per Cleangeartech l'onere della sostituzione o riparazione delle parti difettose ma non ammette ulteriori addebiti per eventuali danni diretti o indiretti di qualsiasi natura. La garanzia decade nel caso in cui siano state eseguite riparazioni o apportate modifiche senza nostro consenso scritto.

**La nostra ditta non si ritiene responsabile per eventuali danni diretti o indiretti derivanti da un uso improprio dei prodotti e dalla mancata osservanza delle indicazioni riportate a catalogo o web.**

**Se il processo richiede una protezione totale, i clienti dovrebbero prendere in considerazione misure aggiuntive per evitare qualsiasi contaminazione derivante dai riduttori.**

# International General sales and warranty conditions

## **Quotations:**

Unless differently agreed, the validity of all quotations is 2 months. The quotations are provided according to the RFQ (request for quotation) which shall contain the complete and detailed specification of the Product, the correctness of which is fully under responsibility of RFQ applicant.

## **Orders:**

Only official orders issued on the Customer's letter-head are accepted. The Order Confirmation (OC) is issued within few days from the order receipt unless the Products configuration issues arise. The OC shall be confirmed in writing within few working days from the OC date and in all its parts – the product code and description, quantities and price, other specific information, if any. The OC is considered confirmed by tacit approval in case no written confirmation is provided by the Customer within 7 days.

## **Production time:**

The average production time for the standard Products is normally 3-4 weeks from the OC confirmation date and/or payment receipt in case of advanced payment term. For some configurations of the standard Products the production time can be longer and shall be advised in the quotation and/or in any case in OC. In the period of Christmas holidays and August holidays the days of company closure are excluded from the abovementioned production term.

Possible delays due to production picks, do not give the buyer a right to require any kind of penalty or indemnity.

## **Delivery terms:**

FCA Sovizzo, Italy (Incoterms 2016)

## **Packaging:**

The products are packed in wooden boxes as a standard packaging. Europallets can be also used on request. The prices and details of the packaging are indicated in the specific section of the Price List.

## **Payment terms:**

The payment should be performed in terms indicated in the invoice and by wire transfer.

## **Prices:**

The prices are indicated in the invoice and intended ex-works, unless differently specified, and do not include any kind of taxes, shipment or other type of costs.

## **Standard Products orders cancellation:**

Modification or cancellation of the orders is accepted only if notified to the Manufacturer in writing and not later than 5 days from the Order Confirmation and in any case before the production of the ordered Products is launched.

## **Special execution of customized products:**

The Products that are not included in the catalogue or configurations of the products that can not be realized using catalogue, options and accessories brochure and/or online configurator are considered Customized Products.

(a) The Manufacturer is entitled to examine feasibility of Special Execution of Customized Products and define the minimum quantity, production time and eventually other special sales and production conditions issuing thereafter a Special Execution Quotation that shall be confirmed by the Customer in writing.

(b) Once the Quotation is confirmed, The Manufacturer shall realize a Special Execution (SE) data sheet with its unique code for each Customized product. The SE data sheet shall be confirmed in full and in writing by the Customer.

(c) The production time of SE is definitely settled by The Manufacturer and notified to the Customer after the SE data sheet confirmation. As a rule, the production time for SE of Customized products is longer than standard.

(d) The orders of Special Execution of Customized products cannot be cancelled unless special written agreement is made before the production of SE is launched.

## **WARRANTY Conditions:**

(a) Warranty period is 12 months from the shipment date.

(b) Warranty period could be extended to 18 months prior written agreement of the parties and in any case excluding wearable parts.

(c) Warranty covers only manufacturing defects. Wearable parts (for example, oil seals or lubricants leakages caused by normal wear) and failures due to the wrong assembling by the Customer are not covered by warranty.

(d) This warranty is also void in any case in which the products have been misused, used in improper environment conditions, configured beyond design limits indicated in the catalogue (especially service factor, loads and type of motors) or damaged, even accidentally or whenever installation instructions have not been strictly followed and in case of any natural disasters, in case of negligence of the Customer and the end user.

(e) The Customer is fully responsible to assure the compatibility of applications and correct mechanical couplings and electrical connections with the specifications of the Products according to The Manufacturer catalogues and technical documentation.

(f) The liability of The Manufacturer is strictly limited to the above-stated obligations and it is therefore clearly agreed that The Manufacturer takes no responsibility for any damage to persons and/or property deriving from accidents of any nature that may occur during use of the Products, whether the warranty is confirmed or otherwise, also in cases of the choice of the Product configuration being recommended by The Manufacturer.

## **WARRANTY Procedure:**

(a) The Customer shall fill in the COMPLAINT FORM and forward it to The Manufacturer along with other relevant information.

(b) The Manufacturer examines the COMPLAINT FORM and confirms or declines the warranty.

(c) The Manufacturer has the right to ask the Customer to send the malfunctioning product back to the Seller for further examination. In case the warranty is not confirmed the Product will be shipped back to the Customer at the Customer expense. If the warranty is confirmed, The Manufacturer shall compensate the shipment costs to the Customer within the limits of the best shipment quotation.

(d) In case the warranty is confirmed the Products shall be substituted at The Manufacturer's expense using ordinary shipment procedure. The express shipment can be used prior the agreement of the parties.

(e) In case the Product cannot be substituted The Manufacturer shall reimburse the value of the Product by issuing of Credit Note or in any other way agreed by the Parties.

## 1) Definizioni

1.1 Ai fini delle presenti condizioni generali di vendita (di seguito denominate "Condizioni di Vendita"), i seguenti termini avranno il significato di seguito ad essi attribuito:

- "Cliente": qualunque società, ente o entità giuridica che acquisti i nostri prodotti;
- "Prodotti": i nostri beni prodotti, assemblati e/o venduti;
- "Ordine/i": ciascuna proposta di acquisto dei Prodotti inoltrata dal Cliente esclusivamente tramite e-mail, fax o web;
- "Vendita/e": ciascun contratto di vendita concluso a seguito del ricevimento da parte del Cliente dell'accettazione scritta dell'Ordine da parte nostra;

## 2) Scopi

2.1 Le presenti Condizioni di Vendita si applicano a tutte le Vendite di Prodotti. Nel caso di contrasto tra le condizioni e i termini di cui alle presenti Condizioni di Vendita e le condizioni e i termini pattuiti nella singola Vendita, quest'ultimi prevarranno. Non saremo vincolati da condizioni generali di acquisto del Cliente (di seguito, "CGA"), neanche nell'ipotesi in cui si faccia loro riferimento o siano contenute negli ordini o in qualsiasi altra documentazione di provenienza del Cliente, senza il preventivo consenso scritto. Le CGA non saranno vincolanti neppure per effetto di tacito consenso.

2.2 Ci riserviamo il diritto di aggiungere, modificare o eliminare qualsiasi previsione delle presenti Condizioni di Vendita, restando inteso che tali aggiunte, modifiche o cancellazioni si applicheranno a tutte le Vendite concluse a partire dal trentesimo giorno successivo alla notifica al Cliente delle nuove Condizioni di Vendita.

## 3) Ordini e Vendite

3.1 Il Cliente dovrà inoltrarci Ordini specifici contenenti la descrizione dei Prodotti, la quantità richiesta, il prezzo ed i termini richiesti per la consegna.

3.2 La Vendita dovrà ritenersi conclusa: (i) nel momento in cui il Cliente riceva una nostra conferma scritta (tale conferma potrà essere inviata via e-mail, fax o mezzi telematici) conforme ai termini e alle condizioni dell'Ordine (ii) o, nel caso in cui il Cliente riceva da parte nostra una conferma scritta contenente termini difformi da quelli contenuti nell'Ordine, decorsi tre giorni lavorativi dalla data di ricezione della conferma contenente termini difformi senza che nel suddetto periodo ci pervenga contestazione scritta da parte del Cliente; (iii) o, in assenza di conferma scritta da parte nostra, nel momento in cui i Prodotti saranno consegnati al Cliente.

3.3 Gli Ordini regolarmente accettati non potranno essere annullati dal Cliente senza il nostro consenso scritto.

## 4) Prezzo dei Prodotti

4.1 I prezzi dei Prodotti saranno quelli indicati nel nostro listino prezzi in vigore al momento dell'inoltro dell'Ordine da parte del Cliente o, qualora il Prodotto non sia inserito nel listino prezzi o il listino prezzi non sia disponibile, quelli indicati nell'Ordine e confermati per iscritto al momento dell'accettazione dell'Ordine. Eccetto quanto diversamente concordato per iscritto tra le parti, i predetti prezzi saranno calcolati franco fabbrica, al netto dell'IVA e degli sconti. Tali prezzi non comprendono i costi di imballaggio, spedizione e trasporto dai nostri locali a quelli del Cliente. Tali costi dovranno essere sostenuti separatamente dal Cliente.

4.2 Manterremo la proprietà dei Prodotti fino alla completa corresponsione del prezzo degli stessi. Il Cliente dovrà compiere tutti gli adempimenti richiesti dalle leggi locali al fine di rendere valida ed eseguibile nei confronti di tutti i terzi la presente clausola di riserva della proprietà anche operando l'iscrizione in ogni apposito registro, ove localmente richiesto.

## 5) Termini di consegna

5.1 Eccetto quanto eventualmente diversamente concordato per iscritto tra le parti, consegneremo i prodotti franco fabbrica presso i propri stabilimenti, così come questo termine è definito negli INCOTERMS 2010 pubblicati dalla Camera di Commercio internazionale nella loro versione più aggiornata, in vigore al momento della consegna. Se richiesto, ci occuperemo del trasporto dei Prodotti a rischio, costi e spese del Cliente.

5.2 La consegna dovrà avvenire entro il termine indicato nell'Ordine come accettato nella conferma d'ordine. I termini di consegna sono indicativi e non sono termini essenziali ai sensi dell'art. 1457 del Codice Civile e, in ogni caso, non includono i tempi di trasporto.

5.3 Salvo quanto previsto dal precedente art. 5.2, non saremo considerati responsabili dei ritardi o della mancata consegna ascrivibili a circostanze che siano fuori dal suo controllo, quali a titolo meramente esemplificativo e senza pretesa di esaustività:

- a) dati tecnici inadeguati o imprecisioni o ritardi del Cliente nella trasmissione di informazioni o dati necessari alla spedizione dei Prodotti;
- b) difficoltà nell'ottenere rifornimenti delle materie prime;
- c) problemi legati alla produzione o alla pianificazione degli ordini;
- d) scioperi parziali o totali, mancanza di energia elettrica, calamità naturali, misure imposte dalle autorità pubbliche, difficoltà nel trasporto, cause di forza maggiore, disordini, attacchi terroristici e tutte le altre cause di forza maggiore;
- e) ritardi da parte dello spedizioniere.

5.4 Il verificarsi di alcuni degli eventi sopra elencati non darà diritto al Cliente di richiedere il risarcimento degli eventuali danni o indennizzi di alcun genere.

## 6) Trasporto

6.1 Eccetto quanto eventualmente diversamente concordato per iscritto tra le parti, il trasporto avverrà sempre a spese e rischio del Cliente. Nel caso in cui, ai sensi dell'art. 5.1, ci venga richiesto di occuparsi del trasporto dei Prodotti, sceglieremo il mezzo di trasporto che si riterrà più appropriato in mancanza di specifiche istruzioni del Cliente.

## 7) Pagamenti

7.1 Salvo diverso accordo scritto tra le parti, emetteremo le fatture al momento della consegna dei Prodotti.

7.2 Il mancato pagamento nel tempo concordato ci darà diritto a di chiedere al Cliente il pagamento degli interessi scaduti al tasso stabilito dal Decreto Legislativo n. 231/02.

7.3 Il mancato pagamento o il ritardo nei pagamenti superiore a 30 giorni ci daranno il diritto di sospendere la consegna dei Prodotti e risolvere ogni singola Vendita sottoscritta. La sospensione della consegna dei Prodotti o la risoluzione delle Vendite non darà il diritto al Cliente di pretendere alcun risarcimento dei danni.

7.4 Ogni reclamo relativo ai Prodotti e/o alla consegna dei medesimi non potrà in alcun caso giustificare la sospensione o il ritardo nel pagamento.

## 8) Non-conformità

8.1 Qualsiasi difformità dei Prodotti consegnati al Cliente rispetto al tipo ed alla quantità indicata nell'Ordine ci dovrà essere denunciata per iscritto entro cinque giorni dalla data di consegna. Qualora la denuncia non venga comunicata entro il predetto termine, i Prodotti consegnati verranno considerati come conformi a quelli ordinati dal Cliente.

## 9) Garanzia

9.1 Salvo diverso accordo scritto tra le parti, garantiamo che i Prodotti sono esenti da vizi/difetti (con esclusione di quelle parti dei Prodotti che non sono di nostra produzione) per un periodo di 12 mesi decorrente dalla data di consegna dei medesimi al Cliente.

9.2 La garanzia non opererà con riferimento a quei Prodotti i cui difetti sono dovuti a (i) danni causati durante il trasporto; (ii) un uso negligente o improprio degli stessi; (iii) inosservanza delle nostre istruzioni relative al funzionamento, manutenzione ed alla conservazione dei Prodotti; (iv) riparazioni o modifiche apportate dal Cliente o da soggetti terzi senza la previa autorizzazione scritta.

9.3 A condizione che il reclamo del Cliente sia coperto dalla garanzia e notificato nei termini di cui al presente articolo, ci impegneremo, a nostra discrezione, a sostituire o riparare ciascun Prodotto o le parti di questo che presentino vizi o difetti.

9.4 Il Cliente dovrà denunciare per iscritto, la presenza di vizi o difetti entro 8 giorni dalla consegna dei Prodotti se si tratta di vizi o difetti palesi, oppure, entro 8 giorni dalla scoperta in caso di vizi o difetti occulti o non rilevabili da una persona di media diligenza.

9.5 I Prodotti oggetto di denuncia dovranno essere immediatamente inviati presso la nostra fabbrica, o in qualsiasi altro luogo che quest'ultima indicherà di volta in volta, a costi e spese a carico del Cliente salvo diverso accordo tra le parti, al fine di consentire l'espletamento dei necessari controlli. La garanzia non copre danni e/o difetti dei Prodotti derivanti da anomalie causate da, o connesse a, parti assemblate/aggiunte direttamente dal Cliente o dal consumatore finale. Qualora, nell'ambito della presente garanzia, un Prodotto o un componente difettoso venisse sostituito, la proprietà del Prodotto o del componente sostituito sarà ritrasferita dal Cliente a noi.

9.6 In ogni caso il Cliente non potrà far valere i diritti di garanzia se il prezzo dei Prodotti non sia stato corrisposto alle condizioni e nei termini pattuiti, anche nel caso in cui la mancata corresponsione del prezzo alle condizioni e nei termini pattuiti si riferisca a Prodotti diversi da quelli per i quali il Cliente intende far valere la garanzia.

9.7 Non riconosciamo alcuna garanzia circa la conformità dei Prodotti alle norme e ai regolamenti di Paesi che non rientrano o non appartengono all'Unione Europea. Nessun'altra garanzia, espressa o implicita, quale, a titolo esemplificativo, la garanzia di buon funzionamento o di idoneità per uno scopo specifico, è concessa con riferimento ai Prodotti.

9.8 Senza pregiudizio a quanto indicato nel precedente art. 9.3 e salvo il caso di dolo o colpa grave, non saremo responsabili per qualsivoglia danno derivante e/connesso ai vizi dei Prodotti. In ogni caso, non saremo ritenuti responsabili per danni indiretti o consequenziali di qualsiasi natura quali, a titolo esemplificativo, le perdite derivanti dall'inattività del Cliente o il mancato guadagno.

## 10) Diritti di Proprietà Intellettuale

10.1 I Diritti di Proprietà Intellettuale sono di totale ed esclusiva nostra proprietà e la loro comunicazione o utilizzo nell'ambito delle presenti Condizioni di Vendita non crea, in relazione ad essi, alcun diritto o pretesa in capo al Cliente. Il Cliente si obbliga a non compiere alcun atto incompatibile con la titolarità dei Diritti di Proprietà Intellettuale.

## 11) Clausola risolutiva espressa

11.1 Avremo facoltà di risolvere, ai sensi e per gli effetti dell'art. 1456 del Codice Civile Italiano, in qualsiasi momento mediante comunicazione scritta da inviare al Cliente, la singola Vendita nel caso di inadempimento delle obbligazioni previste dagli articoli: 4 (Prezzo dei Prodotti); 7 (Pagamenti); 10 (Diritti di Proprietà Intellettuale).

## 12) Mutamento nelle condizioni patrimoniali del Cliente

12.1 Avremo diritto a sospendere l'adempimento delle obbligazioni derivanti dalla Vendita dei prodotti, in base all'art. 1461 del Codice Civile Italiano, nel caso in cui le condizioni patrimoniali del Cliente divenissero tali da porre in serio pericolo il conseguimento della controprestazione salvo che sia prestata idonea garanzia.

## 13) Domicilio legale, legge applicabile e giurisdizione

13.1 Siamo legalmente domiciliati presso la nostra sede principale.

13.2 Le Condizioni di Vendita e ogni singola Vendita saranno regolate e interpretate in conformità alla Legge Italiana.

13.3 Tutte le controversie derivanti da o connesse alle presenti Condizioni di Vendita e/o ad ogni Vendita saranno soggette alla esclusiva giurisdizione del Tribunale di Vicenza.

13.4 Salvo quanto pattuito nel precedente art. 13.3, ci riserviamo il diritto, quando promotore di una azione legale in qualità di attore, di promuovere tale azione nel luogo di residenza del Cliente.

Note



Note





Via della scienza, 13 - 36050 Sovizzo(VI) - ITALY - Tel. +39 0444 1240920 - Fax +39 0444 1240921 - info@cleangeartech.com - www.cleangeartech.com

Distributed from

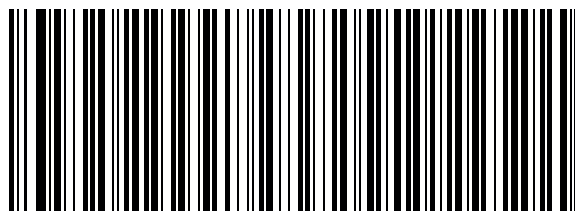

CT-S S MI - CGT019-ML