

Delekatalog

TOR15T50

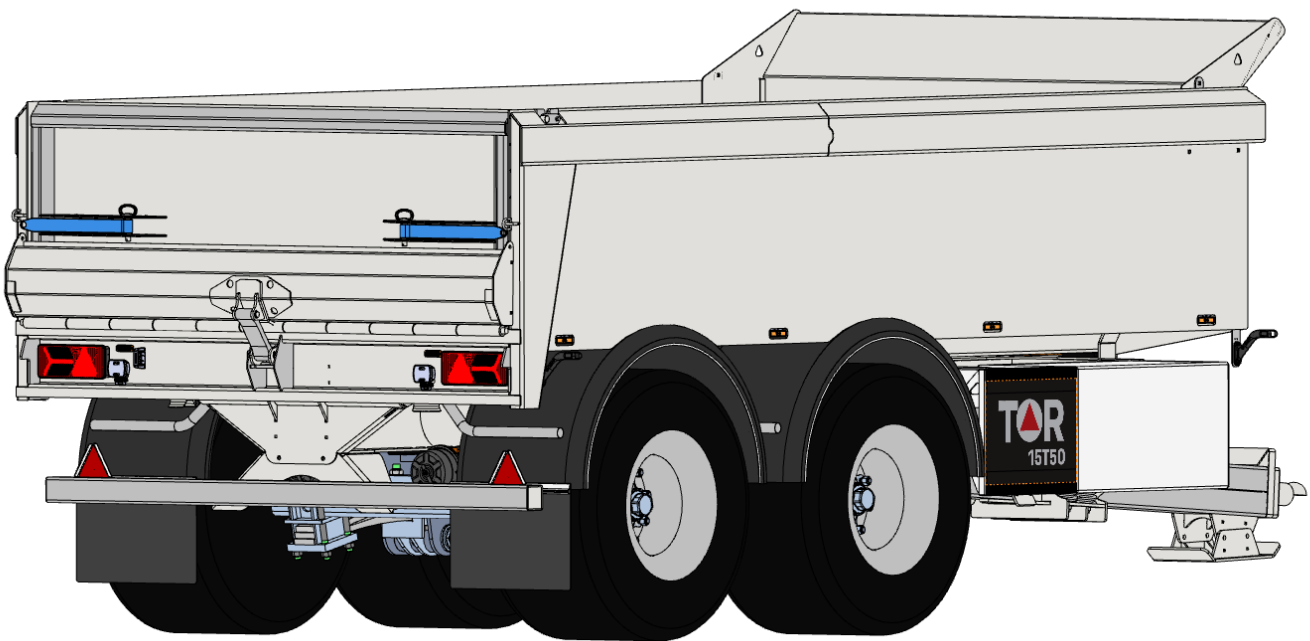

Oppgi alltid serienummer ved bestilling av deler!

Serienummeret finner du på typeskiltet foran på høyre side ved tippsylider.

Bestilling av deler gjøres hos Felleskjøpet.

Innhold

<i>Chassis</i>	3
<i>Kasse</i>	6
<i>Hydraulikk</i>	8
<i>Elektrisk</i>	10
<i>Bremseanlegg</i>	14
<i>Fjæring</i>	16
<i>Bremser</i>	18
<i>ABS</i>	22

Chassis

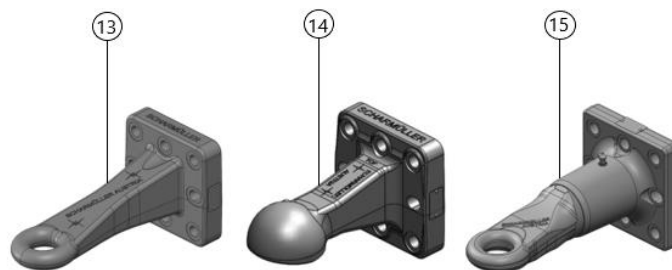
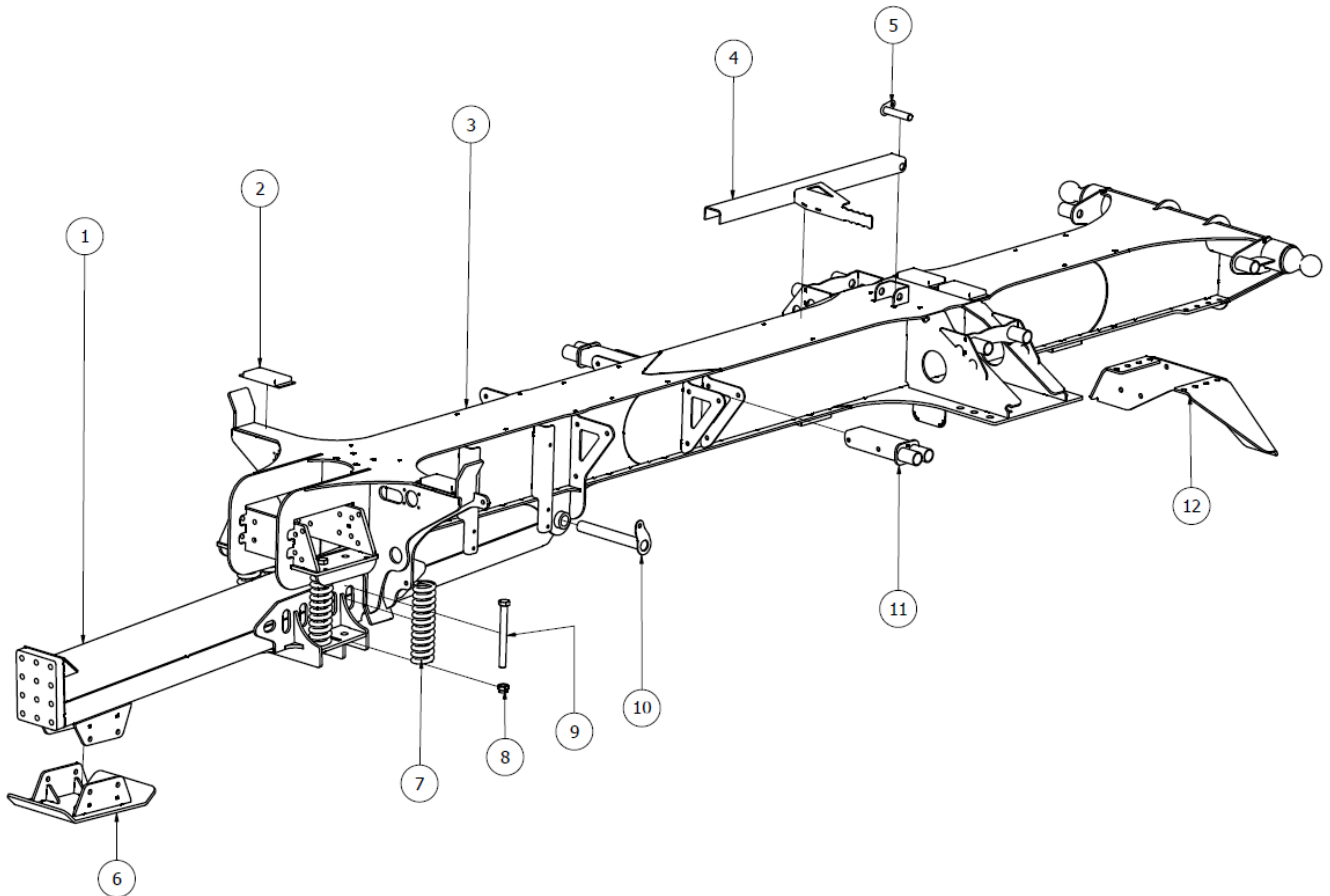

Chassis

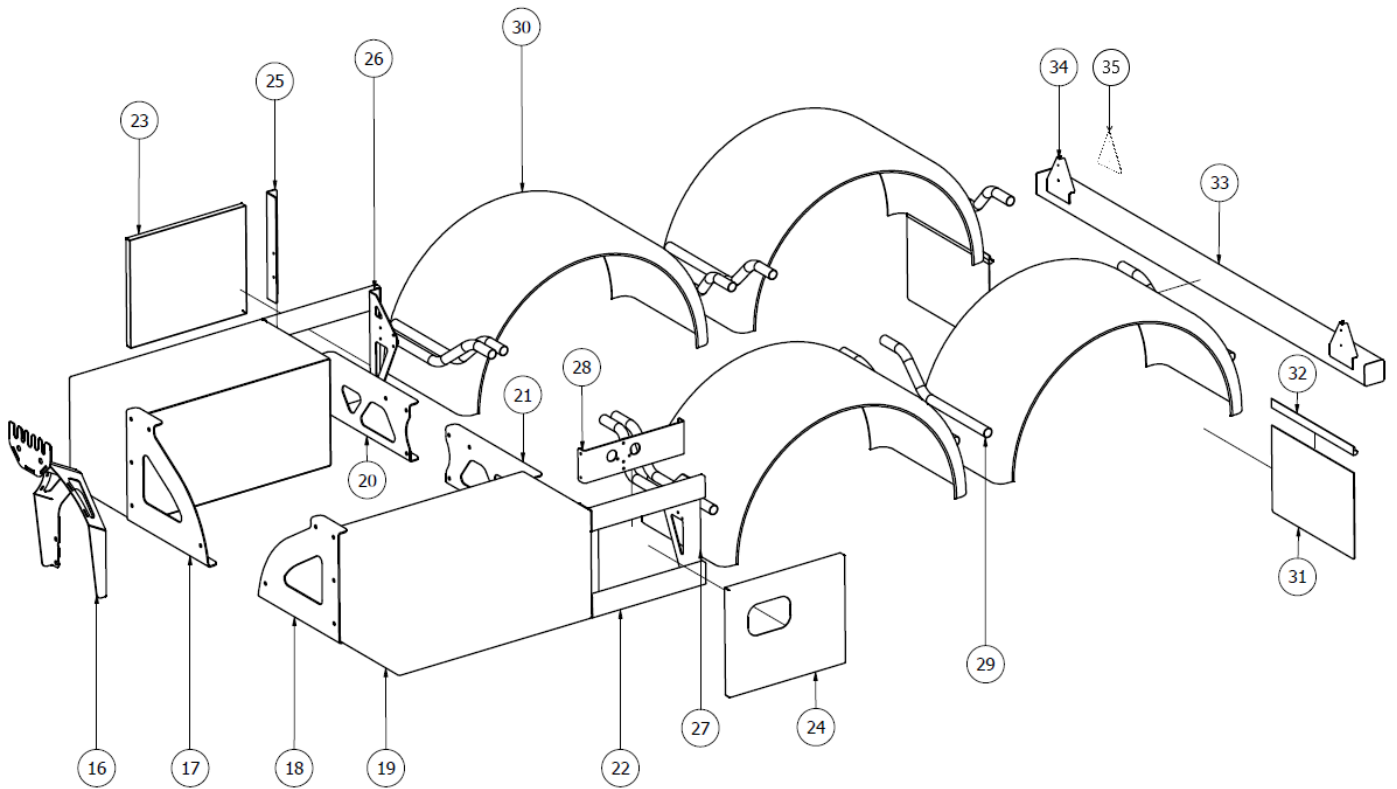

Deler

Pos	Ant	Artikkelnr	Beskrivelse
1	1	R 151002	Drag
2	8	R 151112	Gummibuffer/chassieblock
3	1	R 151001	Senter-ramme
4	1	R 151004	Tippstøtte
5	1	R 151115	Bolt for tippstøtte
6	1	R 151003	Støttefot
7	4	R 151111	Trykkfjær
8	4	R 151117	Mutter M24 8
9	4	R 151116	Bolt DIN931 M24 x 340mm 8,8
10	1	R 151023	Bolt
11	2	R 151022	Feste for skjermbrakett
12	1	R 151005	Festebrakett for U-hinder
13	1	R 151101	Trekkøye 50mm Fast
14	1	R 151102	Kulekobling-K80
15	1	R 151100	Trekkøye 50mm Vribart
16	1	R 151006	Slangetårn
17	1	R 151008	Kassefeste H foran Alu
18	1	R 151009	Kassefeste V foran Alu
19	2	R 151103	Verktøykasse (1000x500x500mm) Alu med rustfri dør
20	1	R 151010	Kassefeste H bak Alu
21	1	R 151011	Kassefeste V bak Alu
22	4	R 151113	Sidehinderplanke 585mm
23	1	R 151020	Deksel H side. Rustfritt
24	1	R 151021	Deksel V side. Rustfritt
25	2	R 151012	Sidehinderfeste H+V skrudd i kasse Alu
26	1	R 151013	Sidehinderfeste H bak Alu
27	1	R 151014	Sidehinderfeste V bak Alu
28	1	R 151015	Festebrakett for Wabco PREV Alu
29	10	R 151105	Skjermbrakett
30	4	R 151104	Skjerm
31	2	R 151106	Skvettlapp
32	2	R 151107	Opphengsprofil skvettlapp
33	1	R 151108	Underkjøringshinder komplett
34	2	R 151007	Refleksbrakett
35	2	R 151201	Trekantrefleks

Kasse

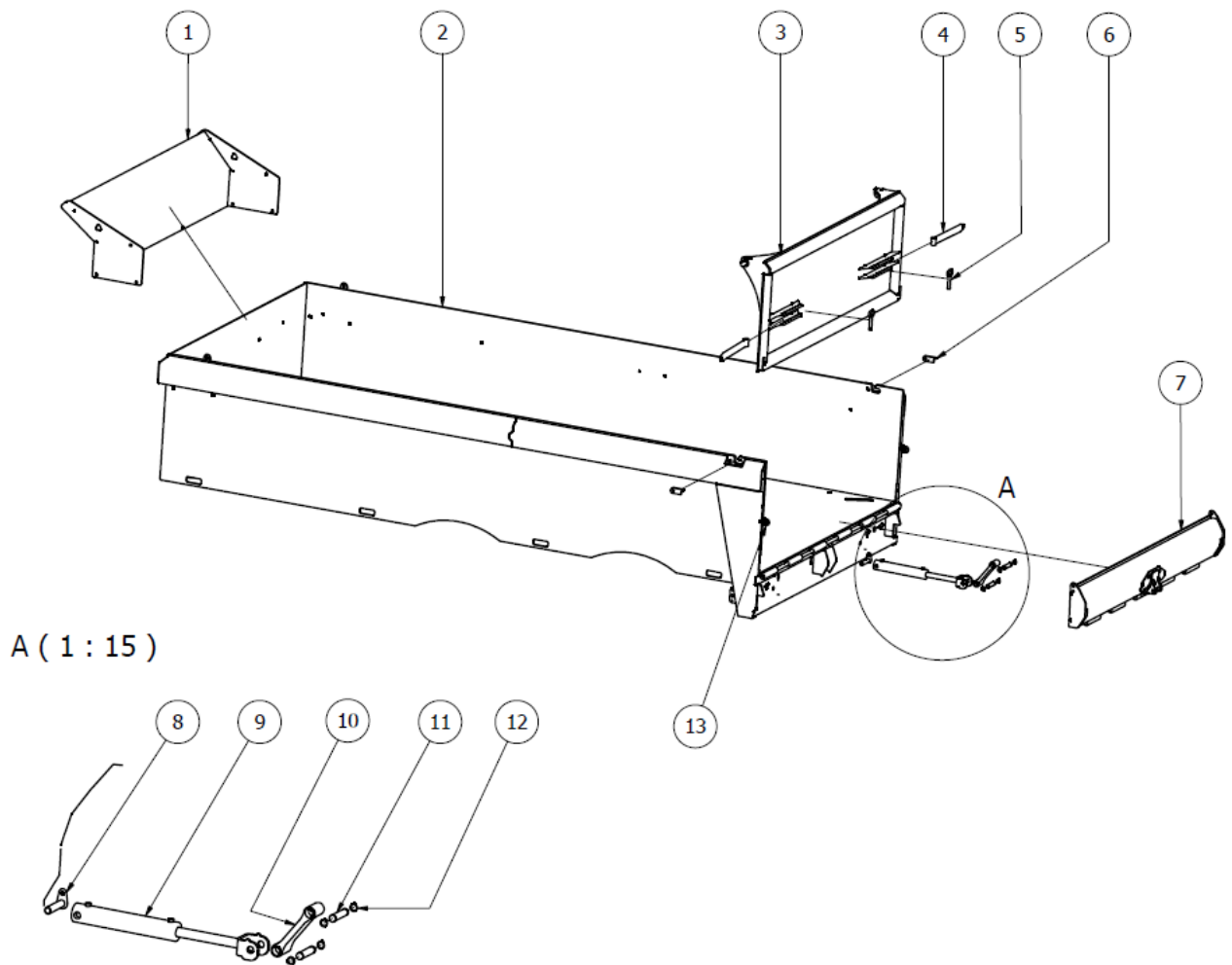

Deler

Pos	Ant	Artikkelnr	Beskrivelse
1	1	R 152005	Frontskjerm
2	1	R 152002	Dumperkasse
3	1	R 152004	Spredelerm
4	2	R 152101	Nylonstropper for spredelerm
5	2	R 152007	Bolt for nylonstropper
6	2	R 152009	Låsklaffer for spredelerm
7	1	R 152003	Automatlem
8	1	R 151115	Bolt
9	1	R 152301	Sylinder
10	1	R 152104	Alu-stag
11	2	R 152010	Bolt
12	4	R 152103	Segerring
13	2	R 152102	Sjakkell

Hydraulikk

Tippsylinder

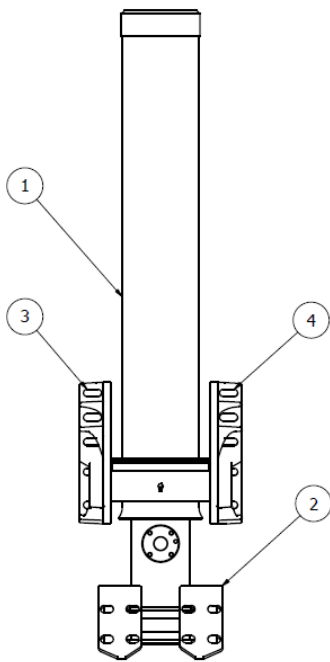

Automatlem sylinder

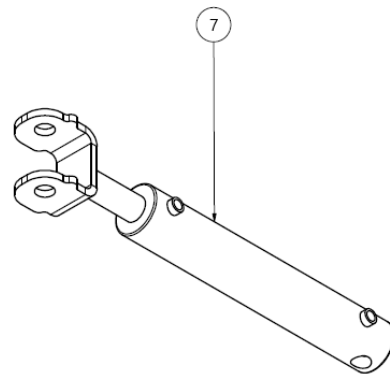

Skjema

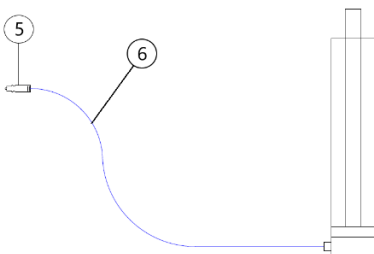

Skjema

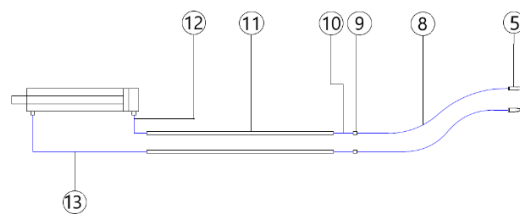

Deler

Pos	Ant	Artikkelnr	Beskrivelse
1	1	R 151301	Tippsylinder
2	2	R 151302	Nedre tippsylinderfeste
3	1	R 151303	Øvre tippsylinderfeste H
4	1	R 151304	Øvre tippsylinderfeste V
5	3	R 151312	1/2" ISO Male
6	1	R 151305	3/4" Hydraulikkslange
7	1	R 152301	Sylinder
8	2	R 151309	3/8" Slange
9	2	R 151311	12mm Skottgjennomføring
10	2	R 151308	3/8" Slange
11	2	R 151310	12mm Hydraulikkør
12	1	R 151306	3/8" Slange
13	1	R 151307	3/8" Slange

Elektrisk Chassis

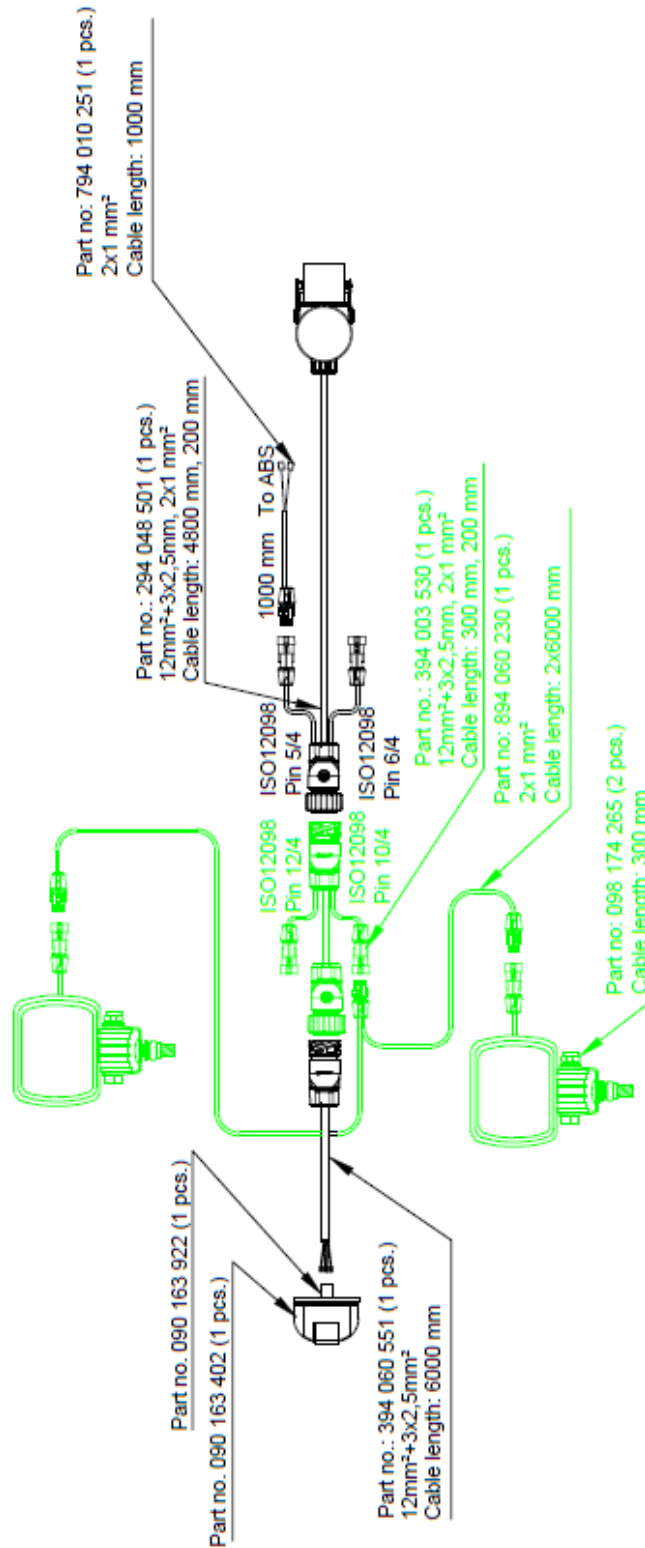

Green parts are optional, NOT included in kit!

Kasse

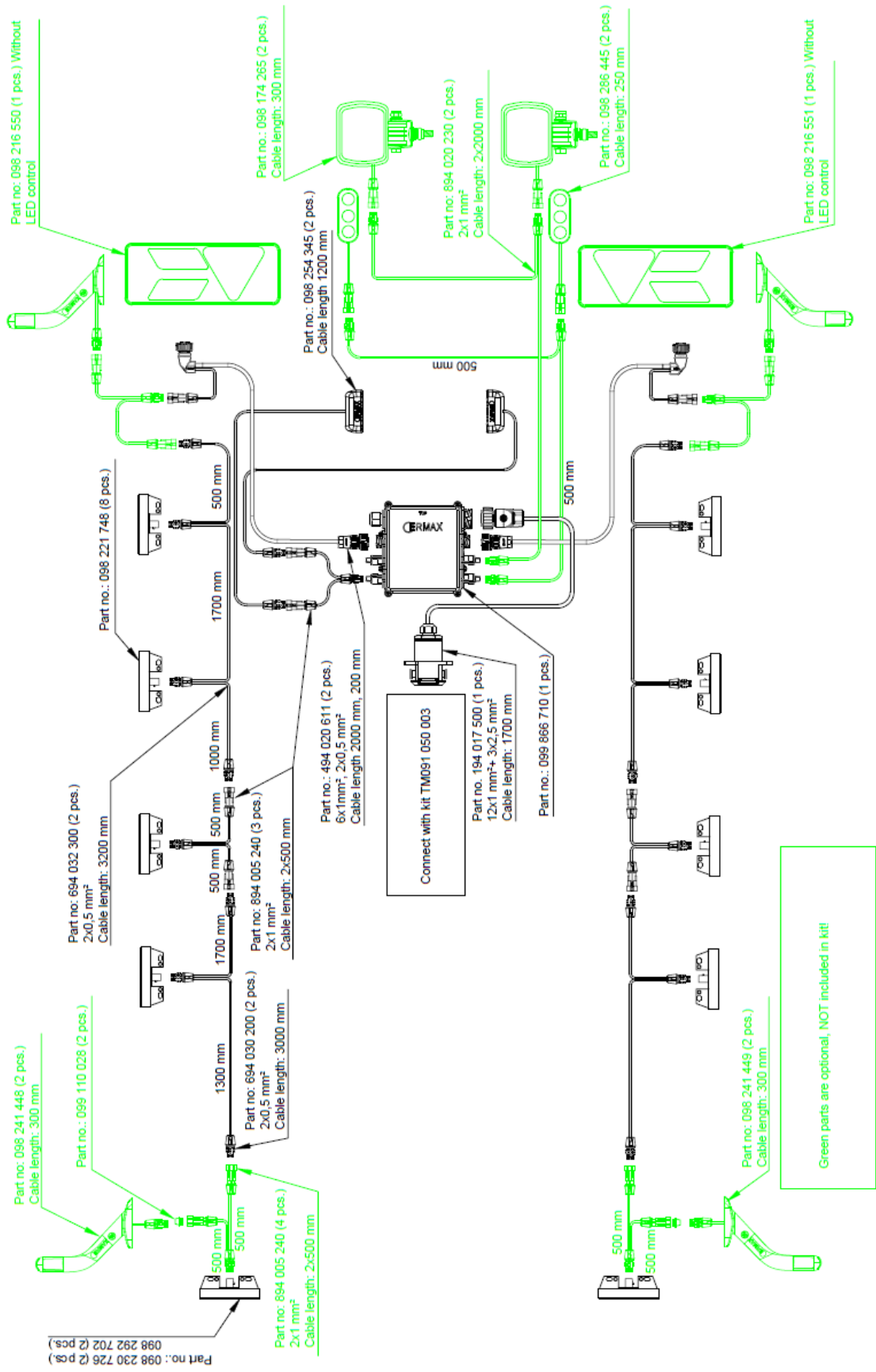

Deler

Pos	Ant	Artikkelnr	Beskrivelse
098216550	1	R 152201	Baklykt Høyre
098216551	1	R 152202	Baklykt Venstre
098221748	8	R 152203	Markeringslys - side. Oransje
098230726	2	R 152204	Markeringslys - foran. Hvit
098292702	2	R 152205	Feste for markeringslys foran
098174265	2	R 152206	Arbeidslys
098254345	2	R 152207	Skiltlys
098286445	2	R 152208	Varsellys
098241448	2	R 152209	Markeringslys - Gummiarm Høyre
098241449	2	R 152210	Markeringslys - Gummiarm Venstre

Bremseanlegg

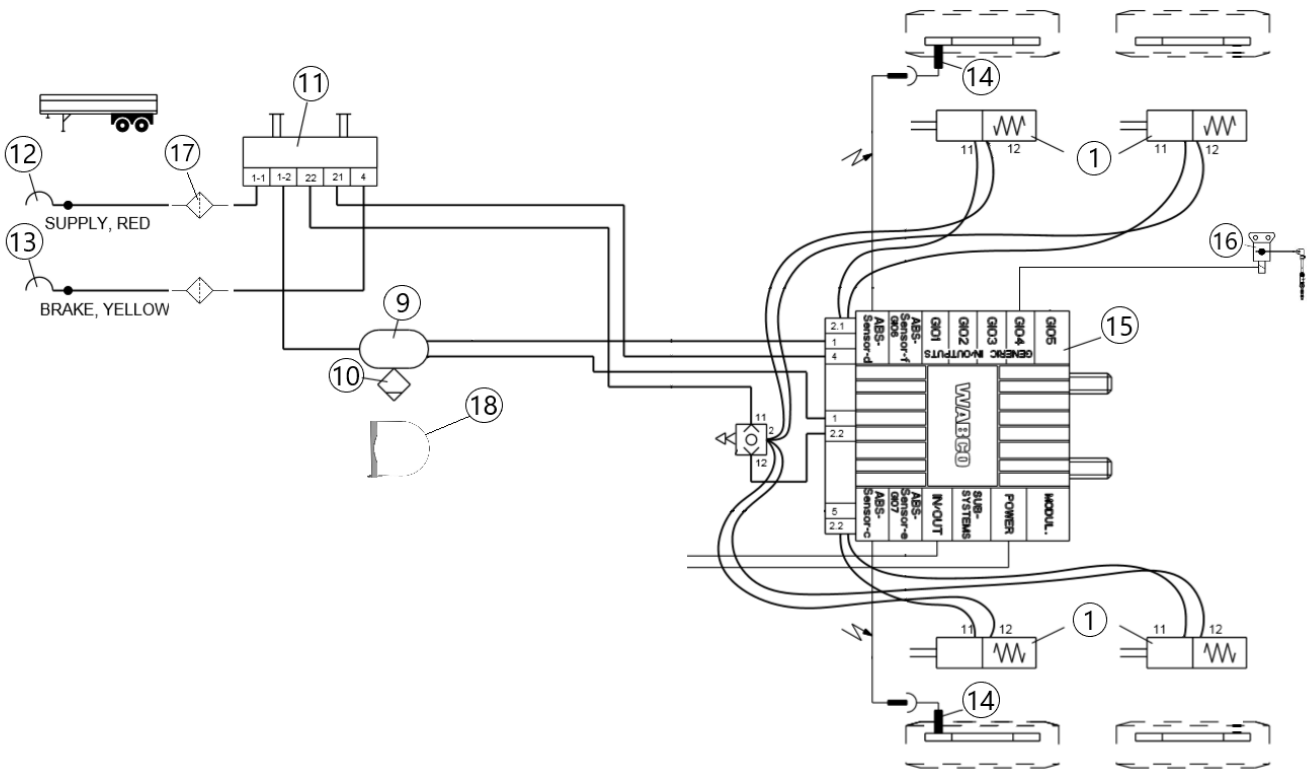
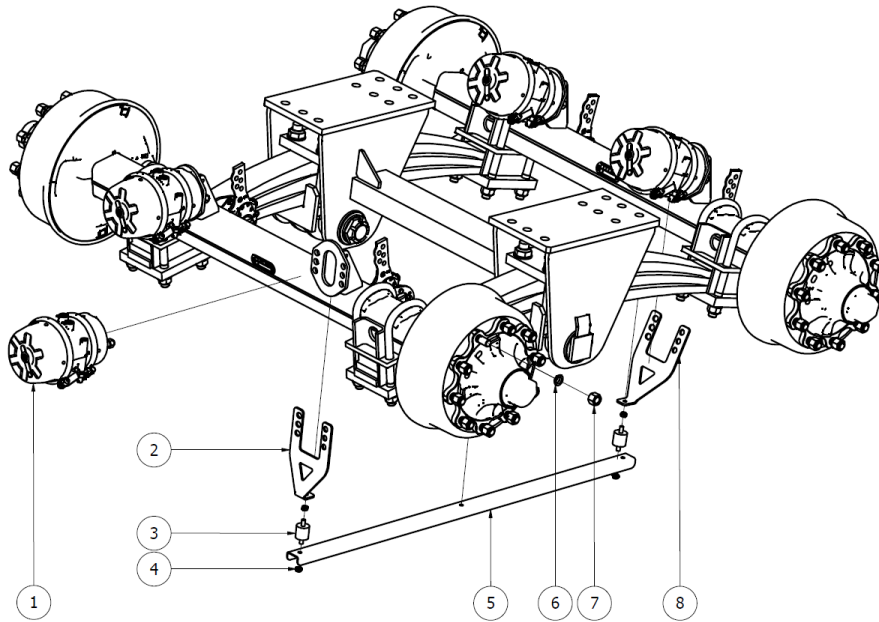

Deler

Pos	Ant	Artikkelnr	Beskrivelse
1	4	R 151404	Fjærbremseklokke DDSB 30/30"
2	1	R 151018	Feste - bak
3	2	R 151114	Gummioppheng
4	4		Mutter M8
5	1	R 151016	Kanal
6	40		Kon
7	40		Hjulmutter
8	1	R 151017	Feste - foran
9	1	R 151405	Lufttank 80L
10	1	R 151409	Dreneringsventil
11	1	R 151408	Wabco PREV
12	1	R 151406	Bremsekobling Rød - Service
13	1	R 151407	Bremsekobling Gul - Brems
14	2		ABS sensor
15	1	R 151401	Wabco TEBS-E Modulator
16	1	R 151402	Wabco veiesensor
17	2	R 151410	Rørfilter
18	2	R 151411	Tankfestebånd Ø396mm

Akselaggregat

Fjæring



BPW Bergische Achsen Kommanditgesellschaft
D-51656 Wiehl, Postfach 1280

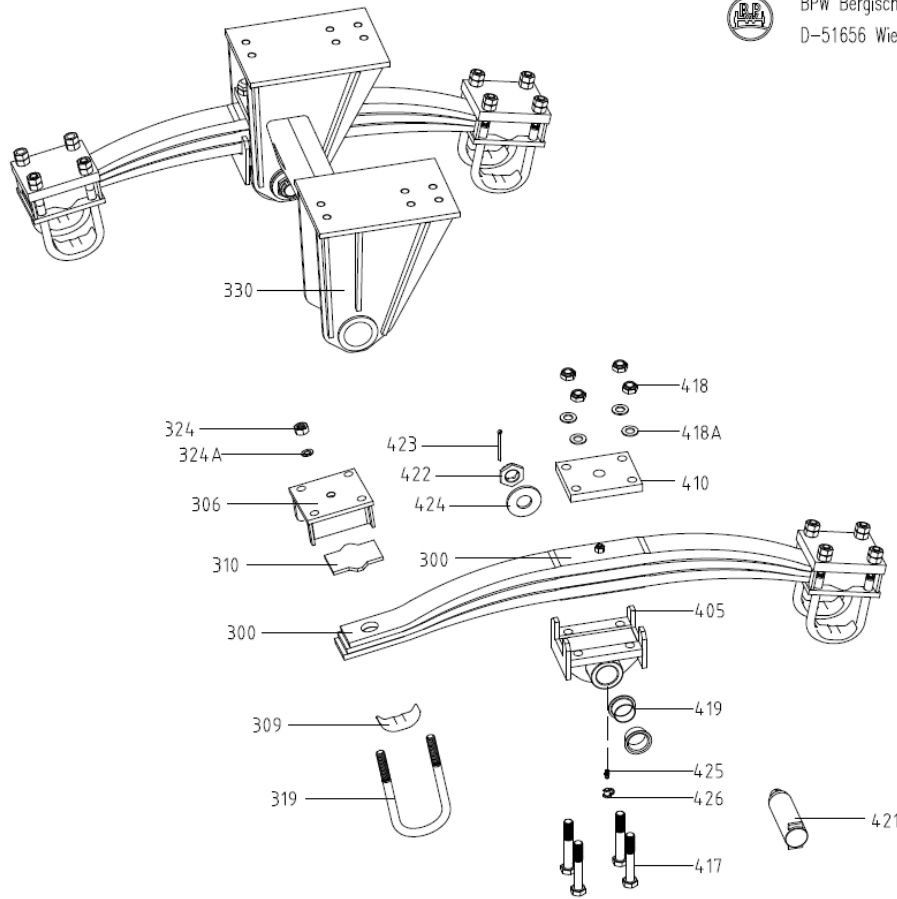

BPW-Doppelachsaggregat GSGWLA

Bild Nr.: 20.096/2

Deler



5688050393_UK.txt

SPARE PARTS LIST

56.88.05.0393

07.01.20

 BPW TANDEM AXLE SUSPENSION GSBW 2/11010-1
 TRACK: 1950 MM
 WITH GSK

VIEW NO.: 20.096/2

ITEM	PART	MEASUREMENT	SERIAL-NO	PER UNIT
1	AXLE		55.88.460.960	1
2	AXLE		55.82.460.009	1
300	LEAF SPRING	12T W1450	05.082.50.49.0	2
306	SPRING SHOE		05.144.13.04.0	4
309	SEGMENT	VK120	03.345.23.02.1	8
310	GUMMI PLATE	T15	03.666.51.77.0	2
319	U-BOLT	M24X310X152	03.138.41.16.4	8
324	LOCK NUT	VM24/980	02.5220.74.12	16
324A	DISC	25/125	02.5401.25.07	16
330	When ordering axle beam assembly please state axle type and BPW-code-no.			1
405	BEARING	FB100	05.030.40.24.0	2
410	SPRING PLATE		03.032.61.78.0	2
417	HEXAGON SCREW	M30X240/931	02.5023.64.80	8
418	HEXAGON NUT	M30	03.260.15.01.0	8
418A	DISC	31/125	02.5401.31.04	8
419	BUSH	70/75/75X40	02.0314.14.00	4
421	THREAD BOLT	D70 L319	03.178.51.12.0	2
422	CASTLE NUT	M52X2	03.262.17.15.0	2
423	SPLIT	8X71/ISO 1234	02.6201.83.03	2
424	DISC	90/53X8	03.321.50.57.0	2
425	GREASE NIPPLE	AS8/71412	02.6850.01.02	2
426	COVER	GPN 985/0201	02.3505.20.00	2

Bremser

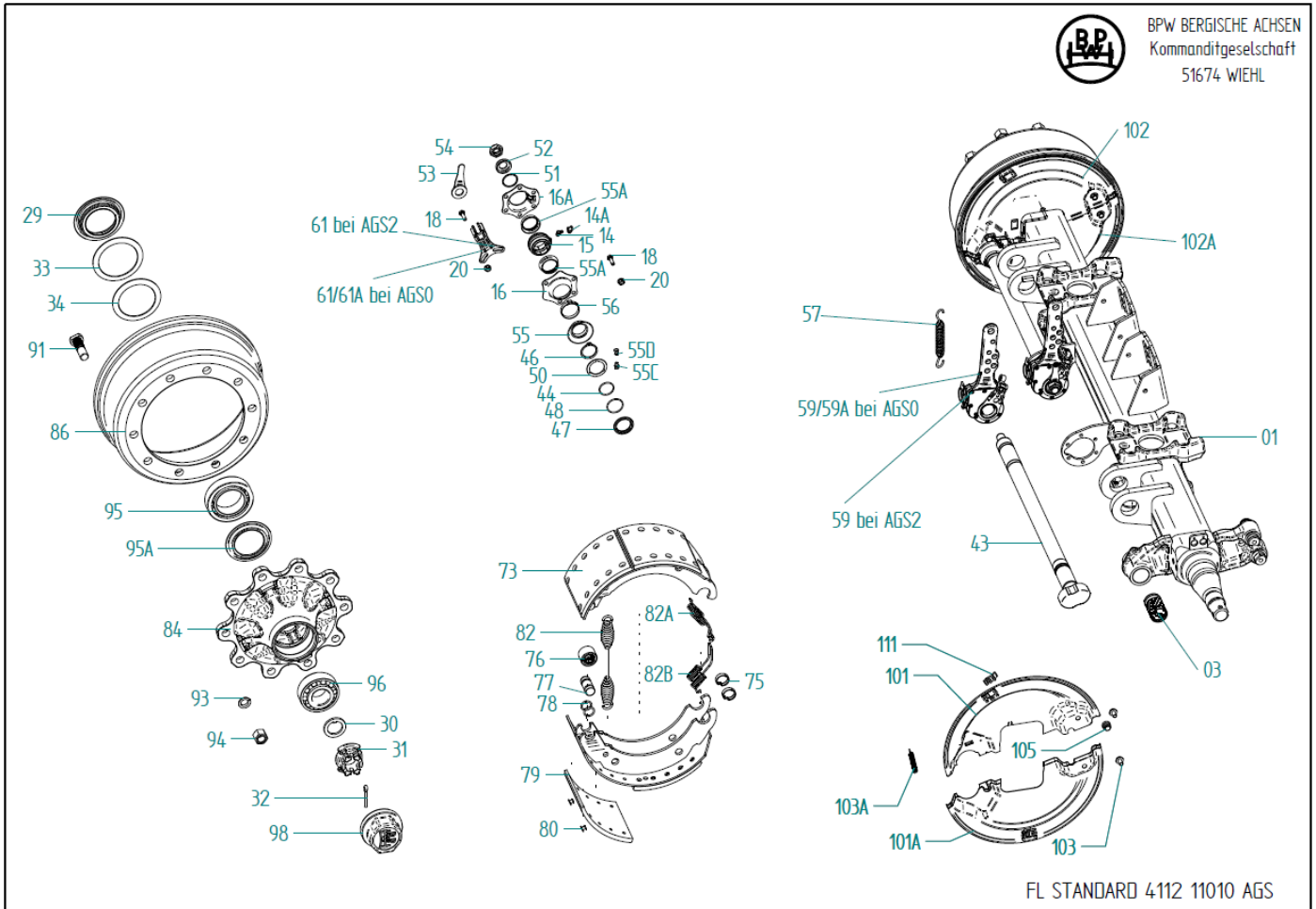

Deler



5582460009_UK.txt

SPARE PARTS LIST

55.82.460.009

06.01.20

BPW-TRAILER AXLE GS 11010-1
BRAKE FL 4112
TRACK 1950 FM 1030
AXLE STUB VK 120X15
WITH Automatic slack adjuster
WHEEL STUD M22X1,5

VIEW NO: FL STANDARD 4112 11010 AGS

ITEM	PART	MEASUREMENT	SERIAL-NO	PER UNIT
1	When ordering axle beam assembly please state axle type and BPW-code-no. (ITEM. 3)			1
3	BUSH	42/46X72.6	03.112.44.34.0	2
13	ASSEMBLY KIT (ITEM.14-20,44-56)	KIT	09.803.80.20.0	1
14	GREASE NIPPLE	BS8X1	02.6850.02.02	2
14A	COVER		02.3505.20.00	2
15	BUSH		03.113.14.04.0	2
16	BEARING BOX		03.229.02.19.0	2
16A	BEARING BOX		03.229.02.18.0	2
18	HEXAGON SCREW	M8X30	02.5025.31.88	8
20	LOCK NUT	M8	02.5273.49.88	8
28	ASSEMBLY KIT (ITEM.29-34,95-96)	KIT	09.803.67.25.0	1
29	THRUST WASHER	33116	05.370.06.48.0	2
30	DISC		03.320.73.13.0	2
31	CASTLE NUT	M42X2	03.262.16.15.0	2
32	SPLIT PIN	8X50/ISO 1234	02.6201.82.01	2
33	RING	136/105X2.5	03.310.97.32.0	2
34	RING	142/111X2,5	03.310.97.31.0	2
43	CAM SHAFT	L=600 A=481,5	05.097.27.36.3	2
44	O-RING	37X2.6	02.5677.37.42	2
46	LOCK RING	42X2,5/471-FST	02.5676.01.00	4
47	RING	55/42X7	03.310.12.24.0	2
48	O-RING	40X2,5	02.5679.23.00	2
50	SEAL		03.120.42.02.0	2
51	CIRCLIP	SW 40	02.5659.40.71	2
52	DISC		03.320.11.16.1	2
53	LEVER		03.190.14.07.1	2
54	LOCK NUT	M22X1,5	05.260.14.12.0	2
55	DISC		03.120.43.14.0	2
55A	SEAL		03.120.42.09.0	4
55C	GREASE NIPPLE	AM10X1/71412	02.6802.03.50	2
55D	COVER		02.3505.20.00	2
56	CIRCLIP		03.350.30.01.0	2
57	RETURN SPRING	D=4 LO=148	05.397.26.03.0	2
59	Automatic slack adjuster	120-165(180=11)	05.174.45.07.3	2
61	SHAPEG PLATE		03.165.25.28.0	2
72	ASSEMBLY KIT (ITEM.73,75,82-82B,)	KIT FL4112	09.803.62.09.0	1
73	BRAKE SHOE ASSEMBLY (ITEM.POS. 75-78,79,80)		05.091.30.04.0	4
75	LOCKING RING		03.188.02.02.0	8
76	ROLLER		05.331.44.02.0	4
77	PIN		03.084.75.24.0	4
78	RING		03.310.70.15.0	8
79	BRAKE LINING		03.092.29.76.0	8
80	RIVET	B8X15/7338	02.5805.80.35	80
82	RETURN SPRING		05.397.58.03.0	2
82A	RETURN SPRING		03.397.33.12.0	2
82B	RETURN SPRING		03.397.33.13.0	2



		5582460009_UK.txt		
84	HUB		03.271.54.90.0	2
86	BRAKE DRUM		03.106.00.10.0	2
91	WHEEL STUD	M22X1, 5X80	03.296.33.11.1	20
92	ASSEMBLY KIT (ITEM.91,93,94)	KIT	09.803.80.14.0	20
93	SPRING WASHER	C22, 5/74361	02.5615.22.94	20
94	NUT	M22X1.5 10 A3C	03.261.50.02.0	20
95	ROLLER BEARING	33116/720	02.6408.80.00	2
95A	COVER		03.010.93.33.0	2
96	ROLLER BEARING	32310/720	02.6406.50.00	2
98	HUB CAP	BPW 115X2	03.212.23.09.0	2
101	DUST COVER		03.010.81.73.0	1
101A	DUST COVER		03.010.81.74.0	1
102	DUST COVER		03.010.81.71.0	1
102A	DUST COVER		03.010.81.72.0	1
103	SCREW	M 10 x 15 / SW 13	02.5071.22.00	4
103A	RETURN SPRING		03.397.11.02.0	2
105	PLUG	GPN 320 - GL22 D22	02.3704.57.00	2
111	PLUG		03.379.00.23.0	4

ABS



BPW BERGISCHE AXSEN
Kommanditgesellschaft
51674 WIEHL

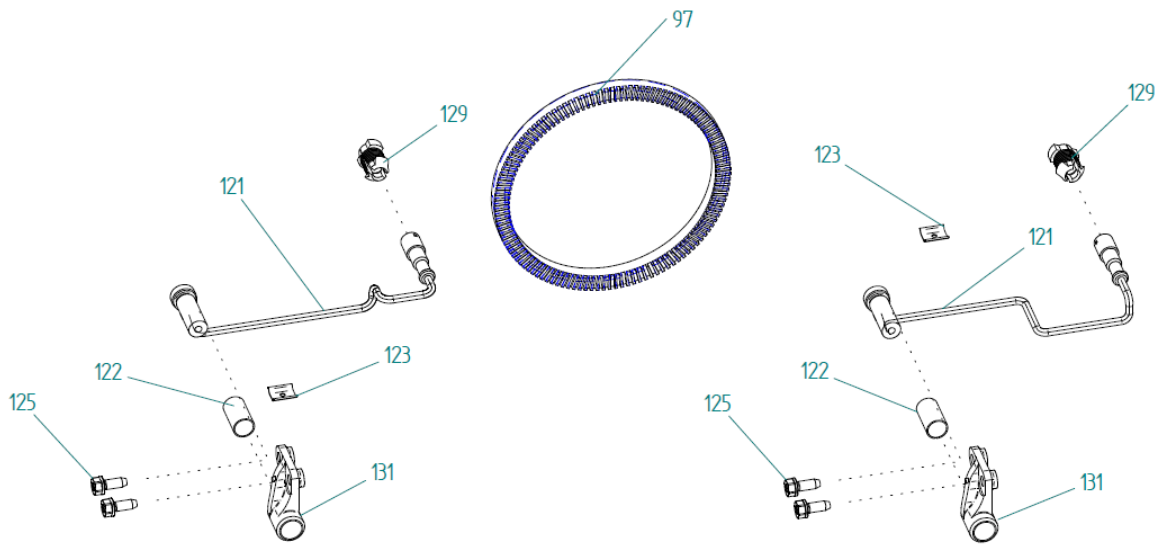
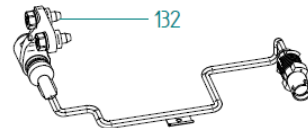
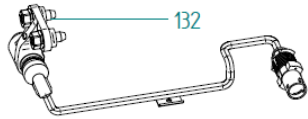

VK 150

VK 150 Luft

Deler



0580361710_UK.txt

SPARE PARTS LIST 05.803.61.71.0 25.04.16

BPW ASSEMBLY KIT SENSOR

VIEW NO: ABS VK 150

ITEM	PART	MEASUREMENT	SERIAL-NO	PER UNIT
121	SENSOR		02.3317.05.00	1
122	BUSH		02.0316.59.00	1
123	CLAMP		02.3707.32.00	1
125	HEXAGON SCREW	M8x20/SW13/Torx Plus 40IP	02.5071.23.00	2
129	SUPPORT		03.189.13.90.0	1
132	SENSOR BRACKET	LE	03.189.07.59.0	1



0580361720_UK.txt

SPARE PARTS LIST 05.803.61.72.0 13.03.18

BPW ASSEMBLY SENSOR

VIEW NO.: ABS VK 150

ITEM	PART	MEASUREMENT	SERIAL-NO	PER UNIT
121	SENSOR		02.3317.05.00	1
122	BOLT		02.0316.59.00	1
123	CLAMP		02.3707.32.00	1
125	LOCKING SCHREW	M8x20/SW13/Torx Plus 40IP	02.5071.23.00	2
129	BRACKET		03.189.13.90.0	1
131	SENSOR BRACKET	RE	03.189.07.58.0	1