

# TANDBERG®

## Programmable FM Tuner 3001

### Circuit Diagrams and Alignment Instructions

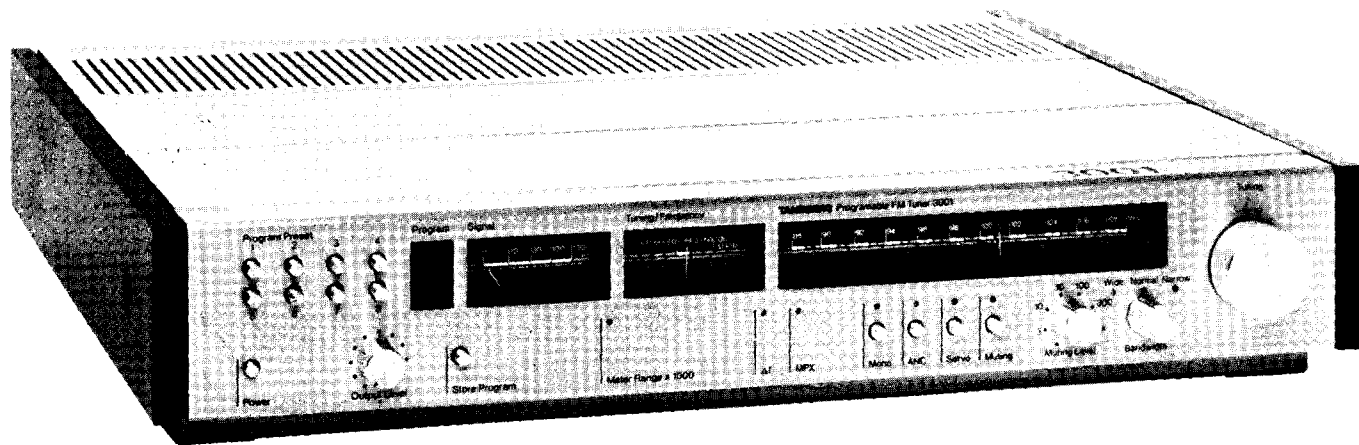

**TANDBERG®** — The European Alternative

## Contents

	Page
Mechanical service .....	3
Electrical service .....	6
Main circuit diagram .....	7
Power supply and dial pointer adjustments .....	8
Oscillator and front end .....	10
Limiter/Detector below serial No. 00700 .....	12
Limiter/Detector above serial No. 00700 .....	14
Selectivity below serial No. 00700 .....	16
Selectivity above serial No. 00700 .....	18
Signal meter, muting level .....	20
Tuning system 1 .....	24
Tuning system 2 .....	26
Stereo decoder .....	28
Integrated circuits .....	32
Other PC boards .....	34
Modifications .....	35
Technical data .....	36

# 1.0 Mechanical service

## 1.1 Dismantling

- Top cover, rear (1).
- Top cover, front (2).
- Rear panel (3).
- Front panel (4). Remove rotary knobs.
- Bottom cover (5).

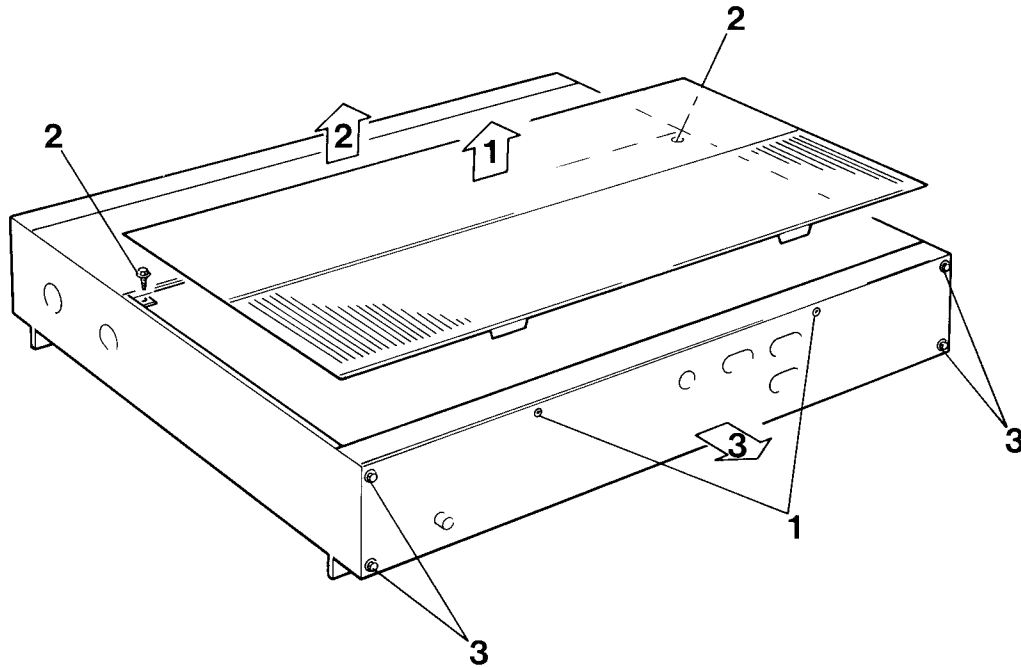

Figure 1 Dismantling the rear and top covers

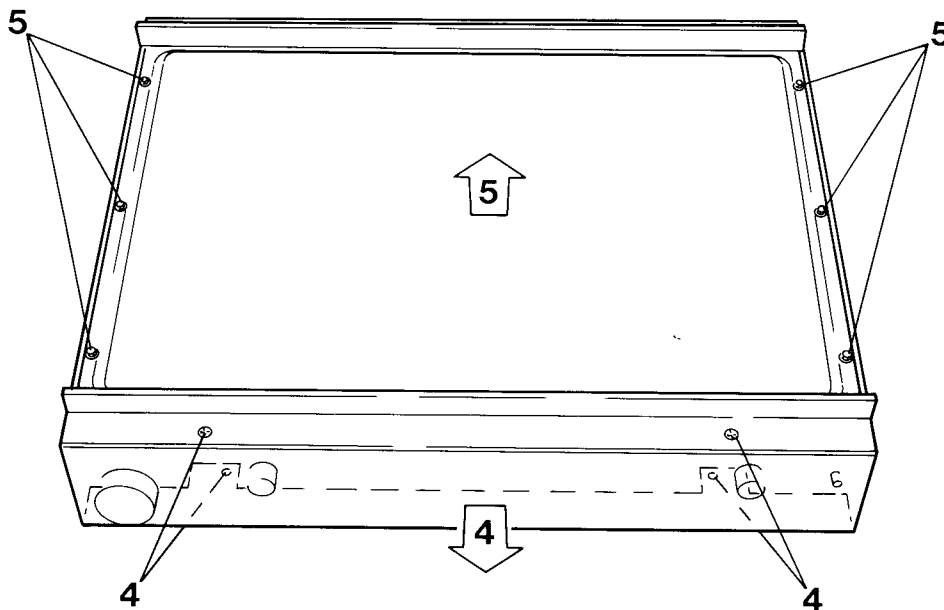

Figure 2 Dismantling the front and bottom covers

## 1.2 Dial cord drive

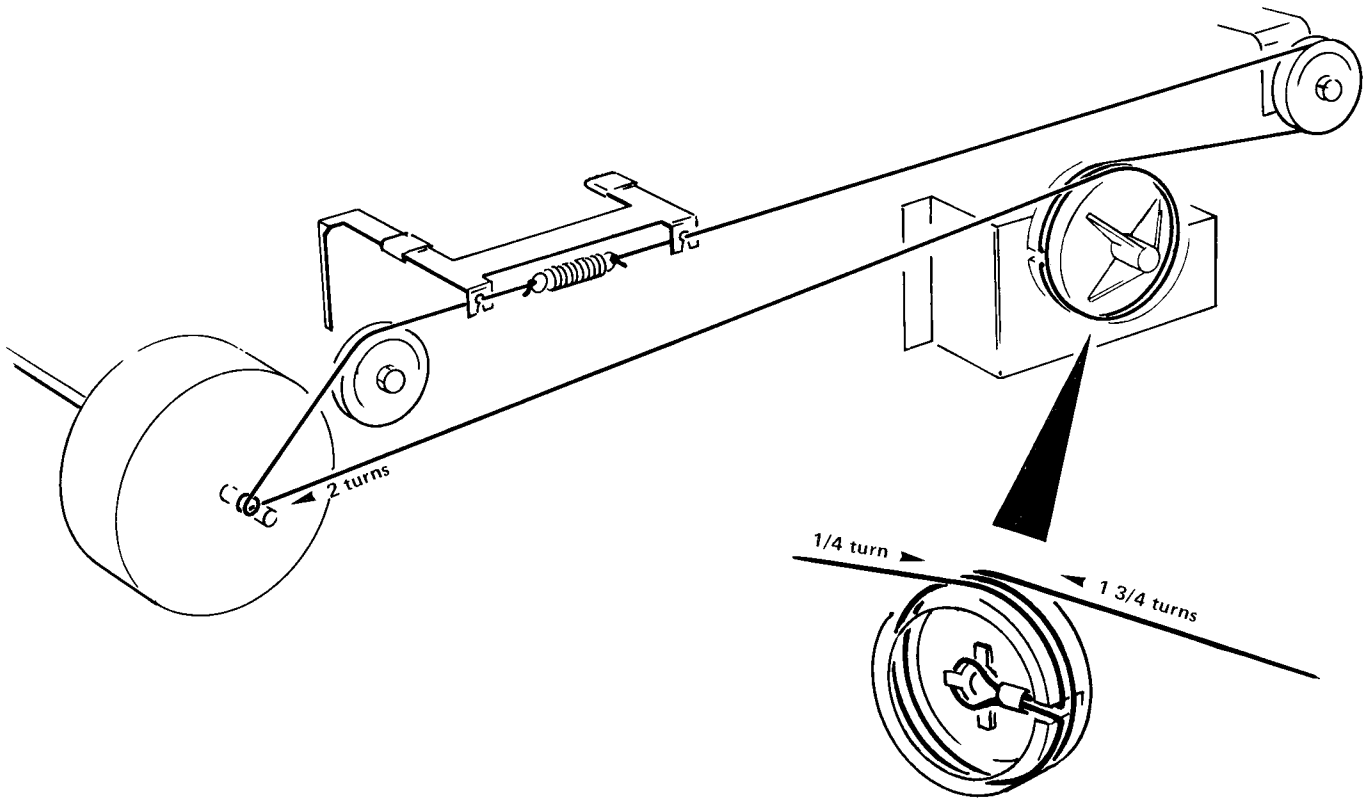
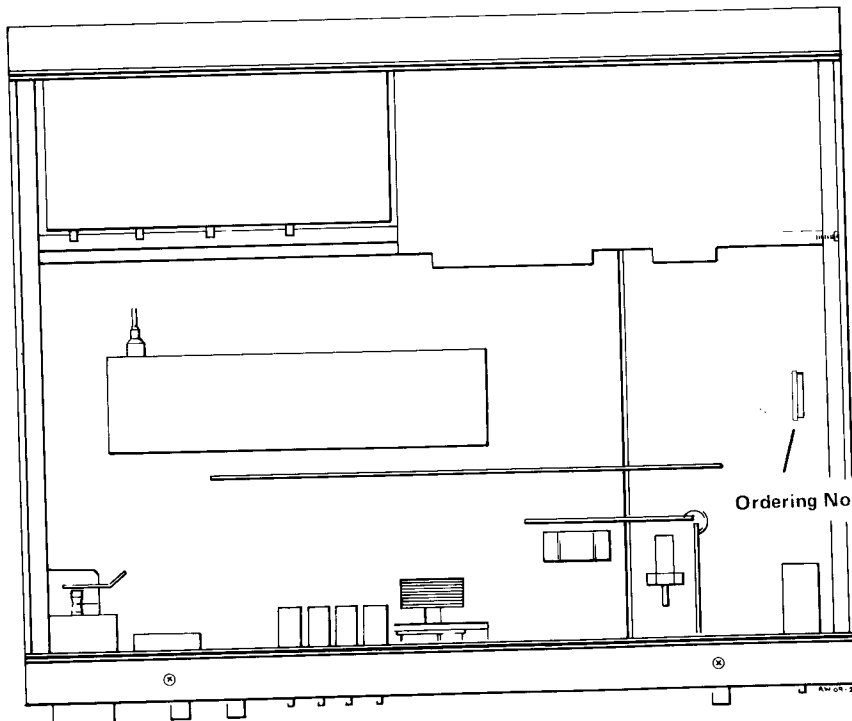

Figure 3 Dial cord drive

## 1.3 Replacing battery in the tuning memory circuit



The memory is powered by an internal battery so that the stored data is not lost when the receiver is switched off.

The battery is the NiCd type, 1.4 V, and is charged continuously when the receiver is switched off.

Under normal conditions the battery will have a life of 10 years.

Figure 4 The tuning circuit battery

## 1.4 Mounting side panels and the 19"-rack mount kit

### NOTE!

When fitting extra side panels you must use the long screws (A) which are supplied.

Take care of the short screws (B) originally used to hold the side panels because you will need them if you remove the extra side panels. The long screws must not be used without the extra side panels because they will cause damage inside the receiver.

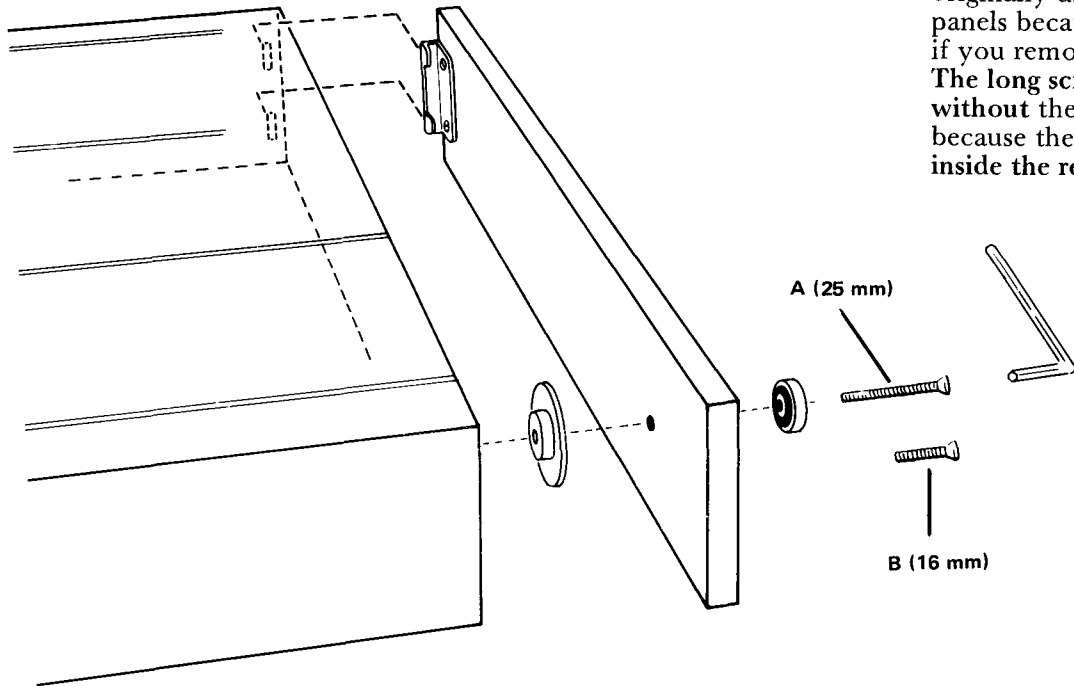

Figure 5 Mounting the side panels (extra)

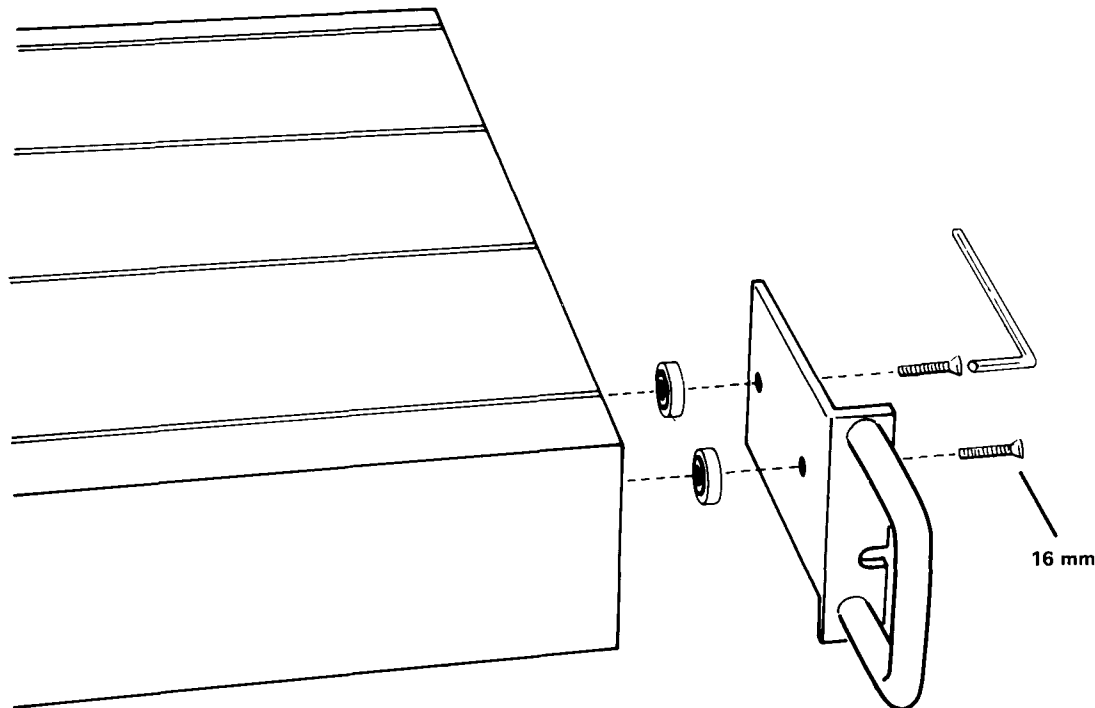

Figure 6 Mounting the 19"-rack mount kit (extra)

## 2.0 Electrical service

Tandberg Programable Tuner TPT 3001 is a professional tuner. Some of its specifications are difficult to measure with standard test equipment and consequently the most critical circuits will need an utmost accurate alignment demanding high quality test equipment.

In case of malfunction we will therefore advise you:

**NEVER TOUCH** trimming components unless you know for sure they need adjustment.

For alignment of distortion and channel separation the generators own distortion figure should be lower than 1/5 of the TPT 3001 distortion figures and the channel separation of the equipment should be 14 to 20 dB higher than that of the TPT 3001.

For a complete alignment we recommend you to follow the procedure in the same order as described in this book:

	Chapter	Procedure	Page
1.	2.2	Power supply and dial pointer	8
2.	2.3	Oscillator and front end	10
3.	2.4	Limiter/detector below serial No. 00700	12
	2.5	Limiter/detector above serial No. 00700	14
4.	2.6	Selectivity below serial No. 00700	16
	2.7	Selectivity above serial No. 00700	18
5.	2.8	Signal meter and Muting level	20
6.	2.9	Tuning system 1	24
7.	2.10	Tuning system 2	26
8.	2.11	Stereo decoder	30

For further information, contact our representative.

2.1 Main circuit diagram with connections.  
 Printed circuit boards and adjustments, see pages 20 through 23

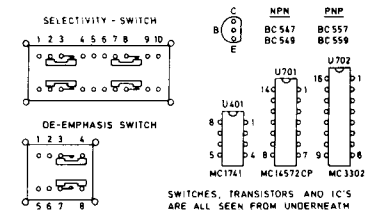
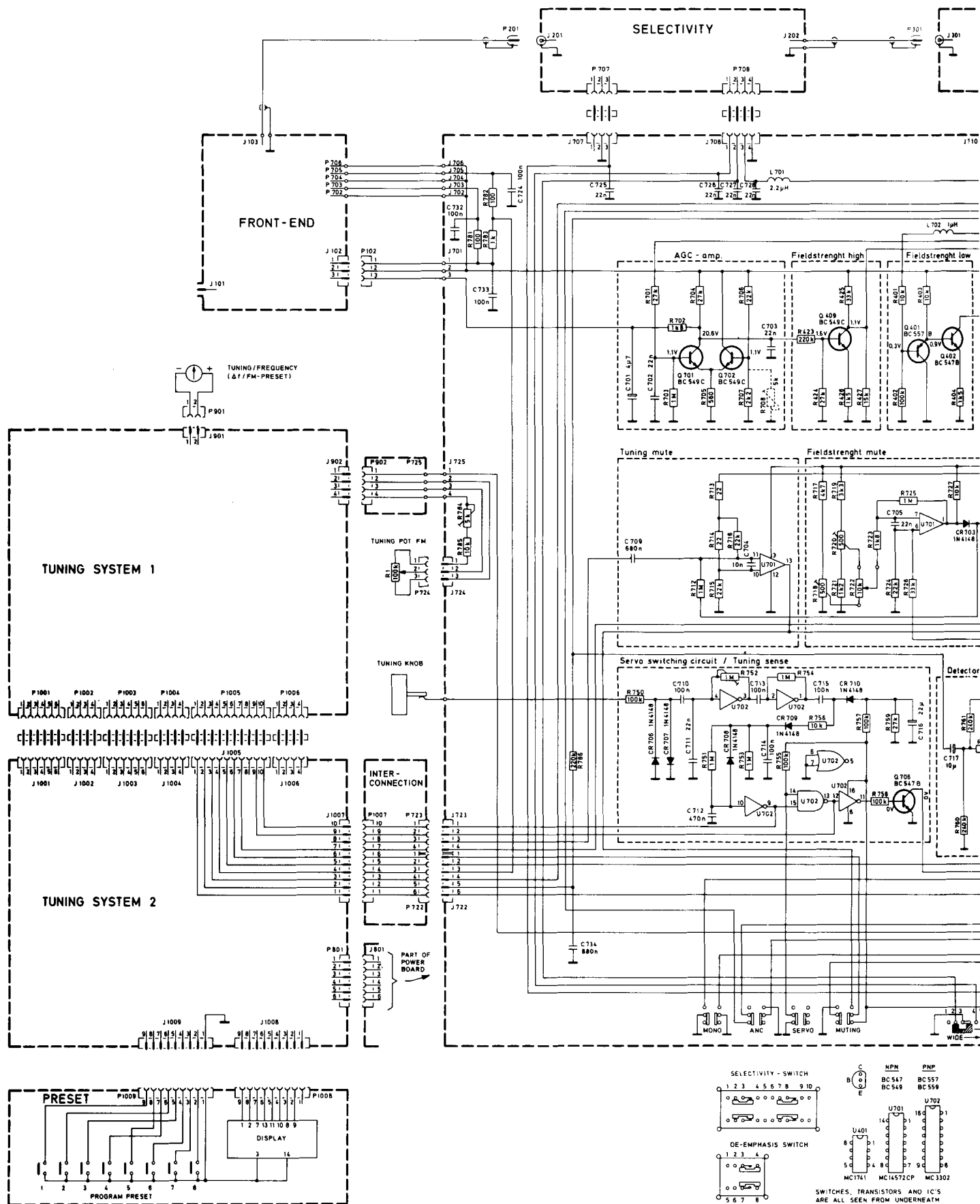

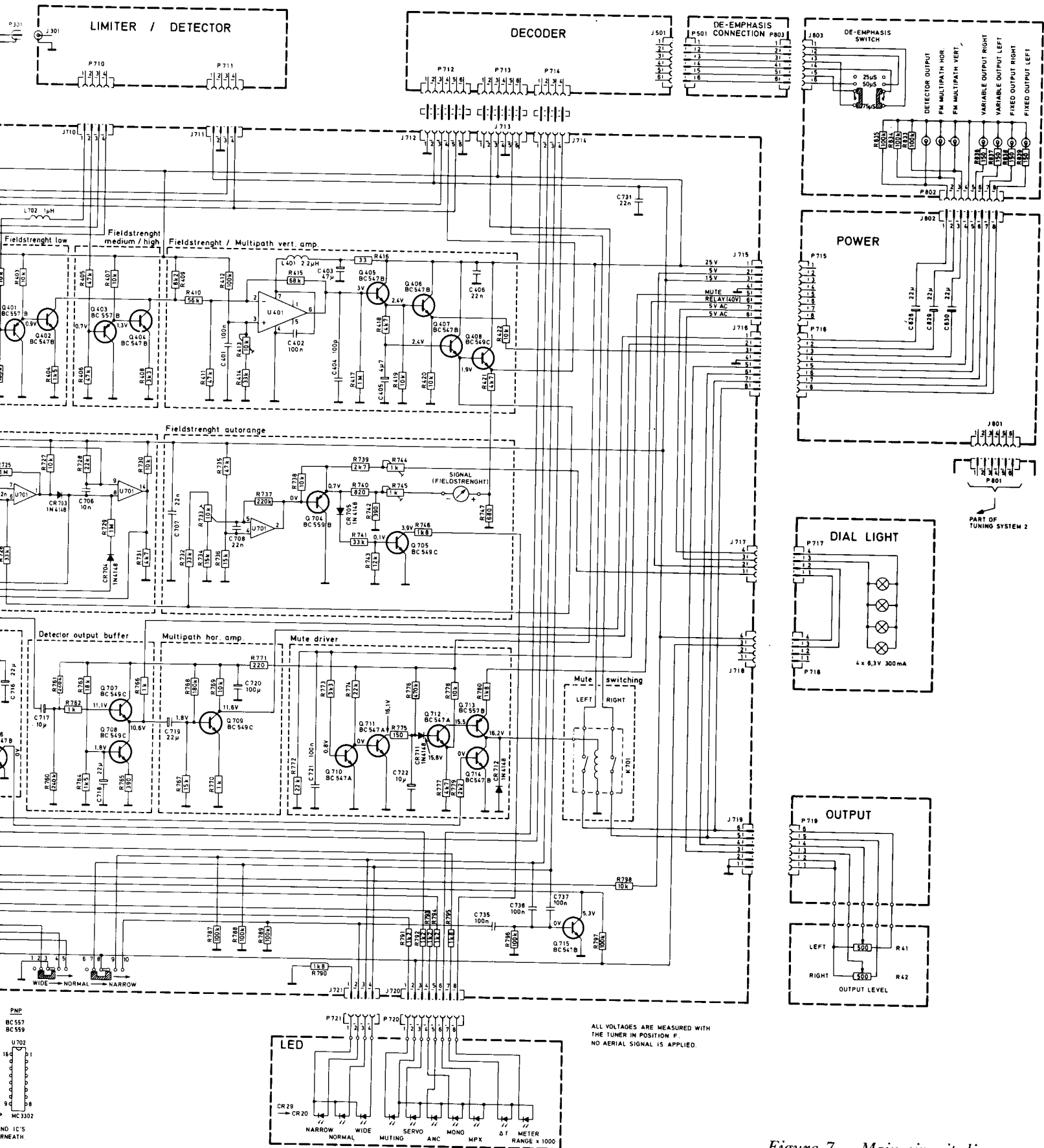
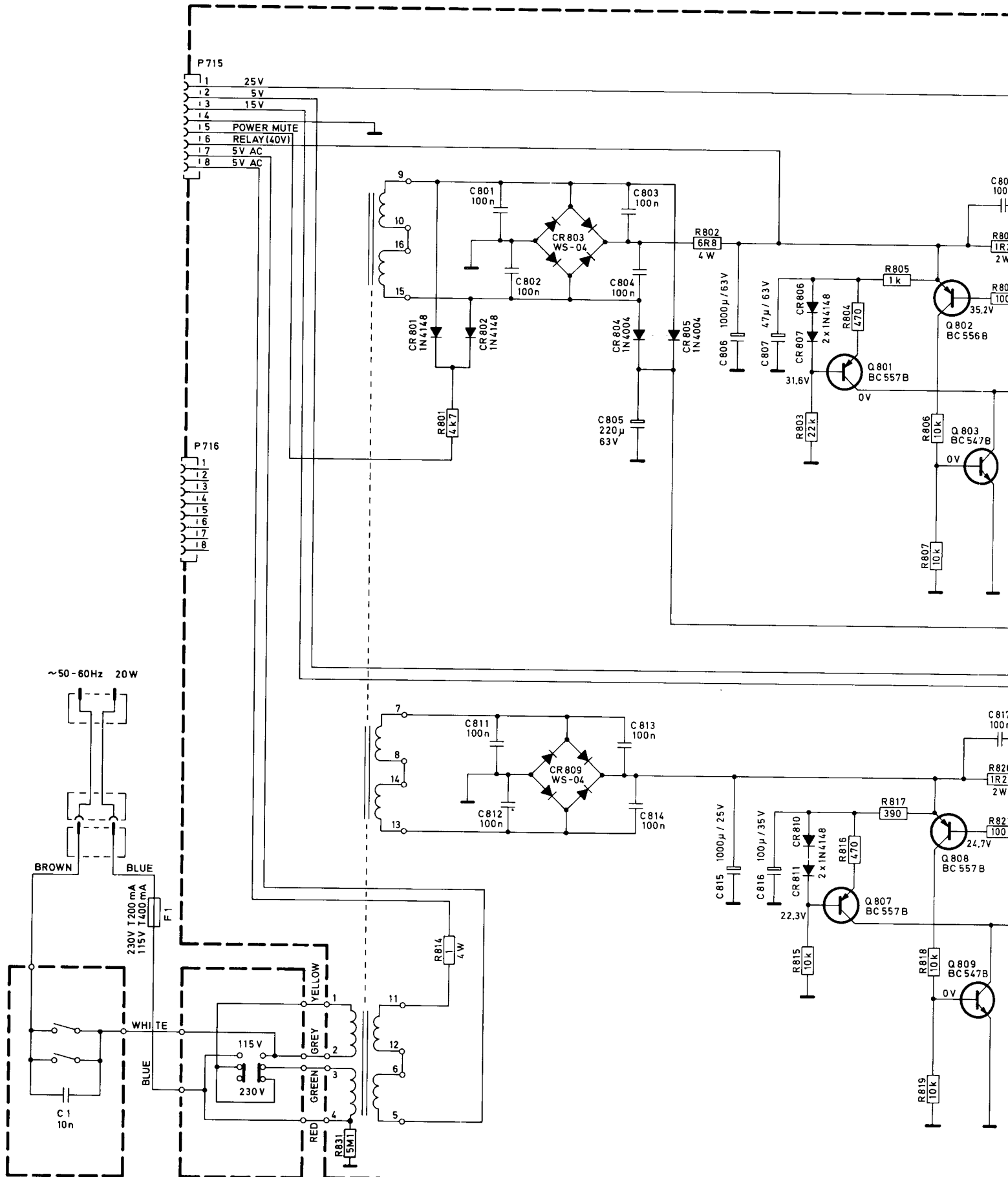

Figure 7 Main circuit diagram



## 2.2 Power supply and dial pointer adjustments





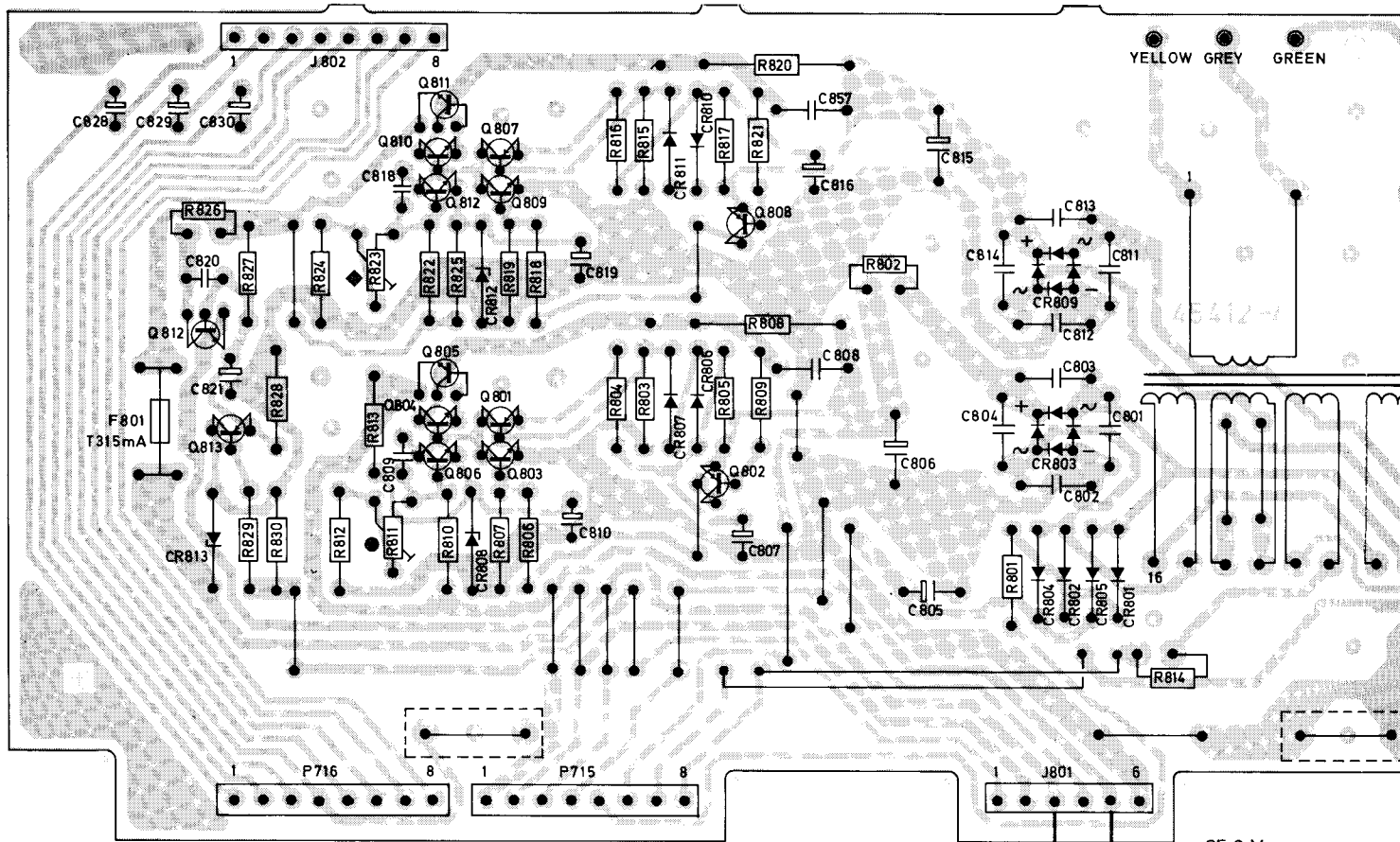

Figure 9 Power supply board, foil side

25.0 V  
Adjustable with R811

15.0 V  
Adjustable with R823

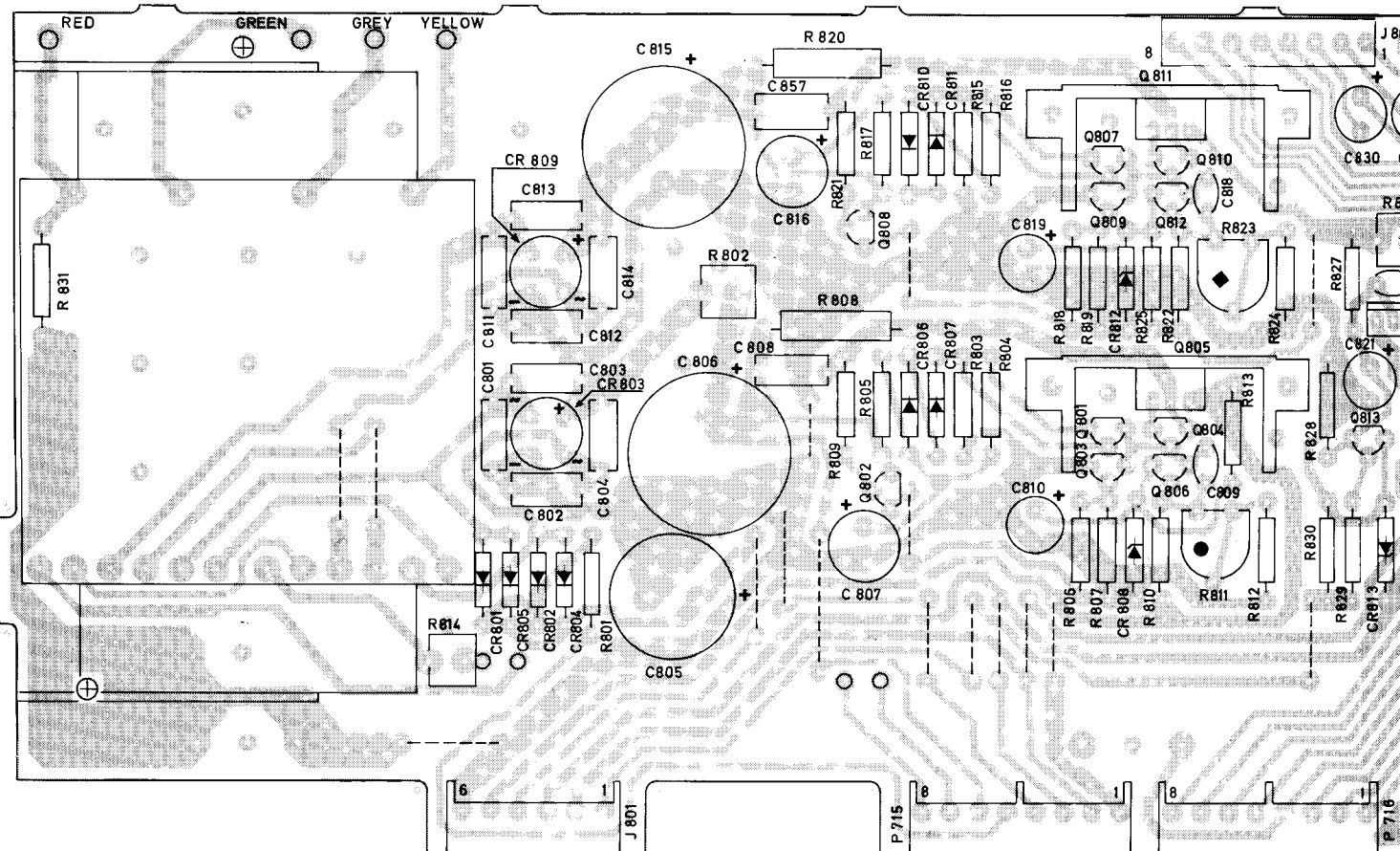
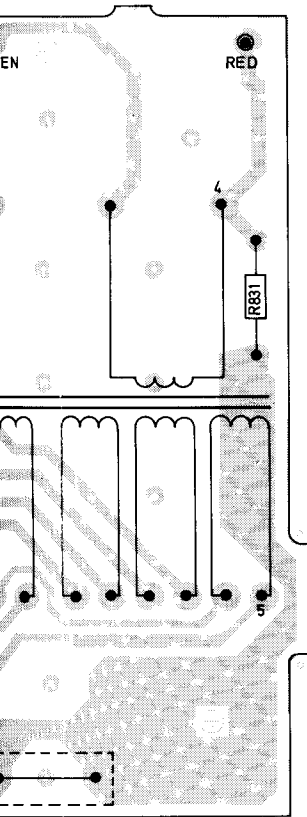
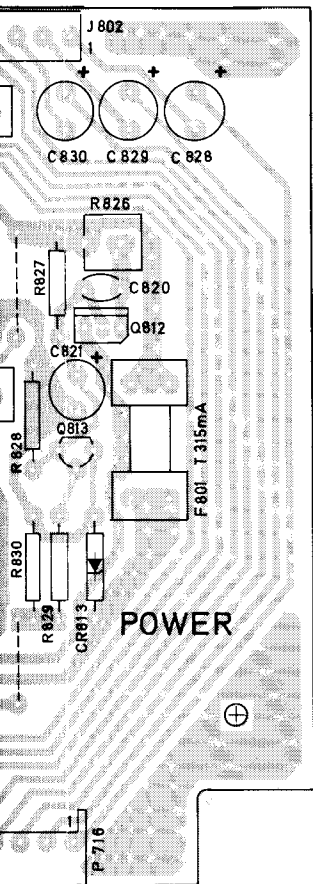

Figure 10 Power supply board, component side



with R311 ●  
with R823 ◆



## Power

Check operating voltages at connector J801:

- P1: 5 V (5.2 V)
- P2: 5 V (5.2 V)
- P3: 15.0 V, adjust with R823
- P4: 40 V
- P5: 25.0 V, adjust with R811
- P6: ground terminal.

## Dial pointer (varicap-voltages)

- Connect voltmeter to J705 (main board, see figure 11).

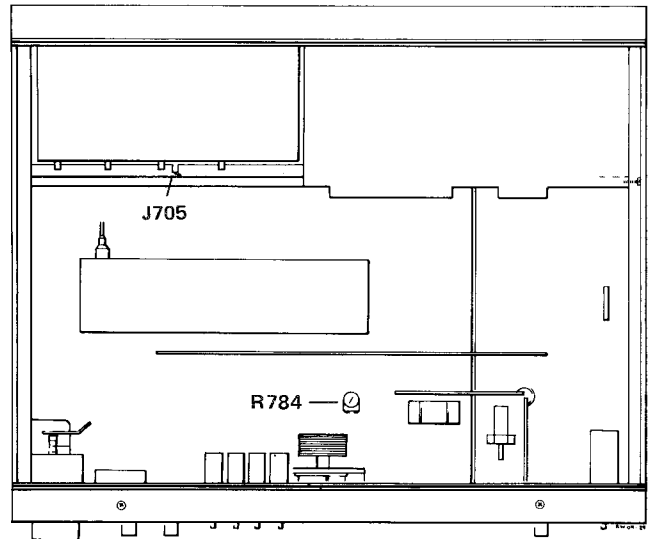

Figure 11 Dial pointer adjustment

- Turn the Tuning knob until the tuning pot. meter is in its physical extreme position with the dial pointer at the low frequency end of the dial.
- Adjust R784 for 3.0 V on the voltmeter.
- Turn the Tuning knob for 4.0 V on the voltmeter. The pointer should then be at the 90 MHz mark on the dial. If necessary, adjust the pointer position.

### 2.3 Oscillator and front end

ANTENNA

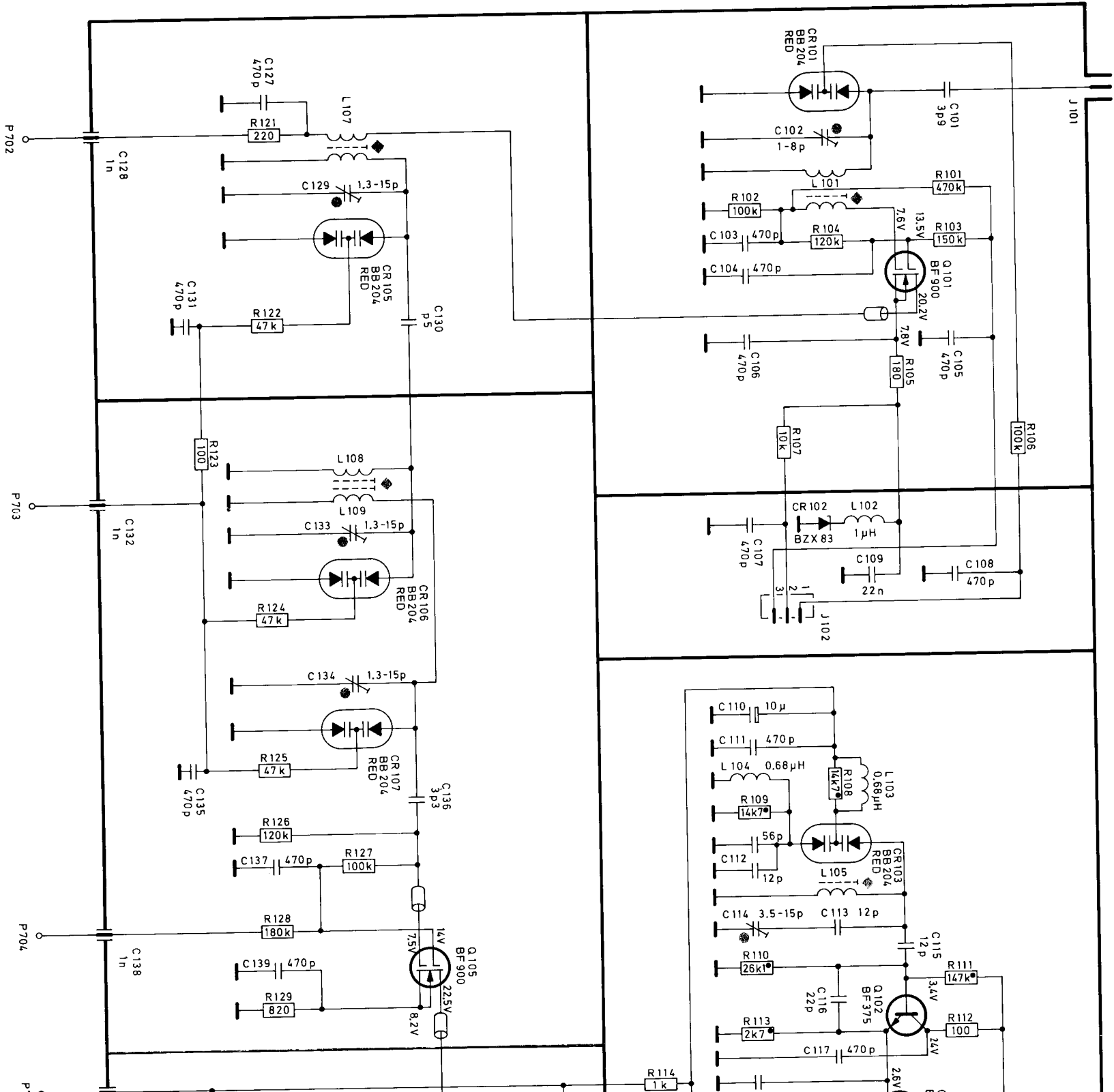
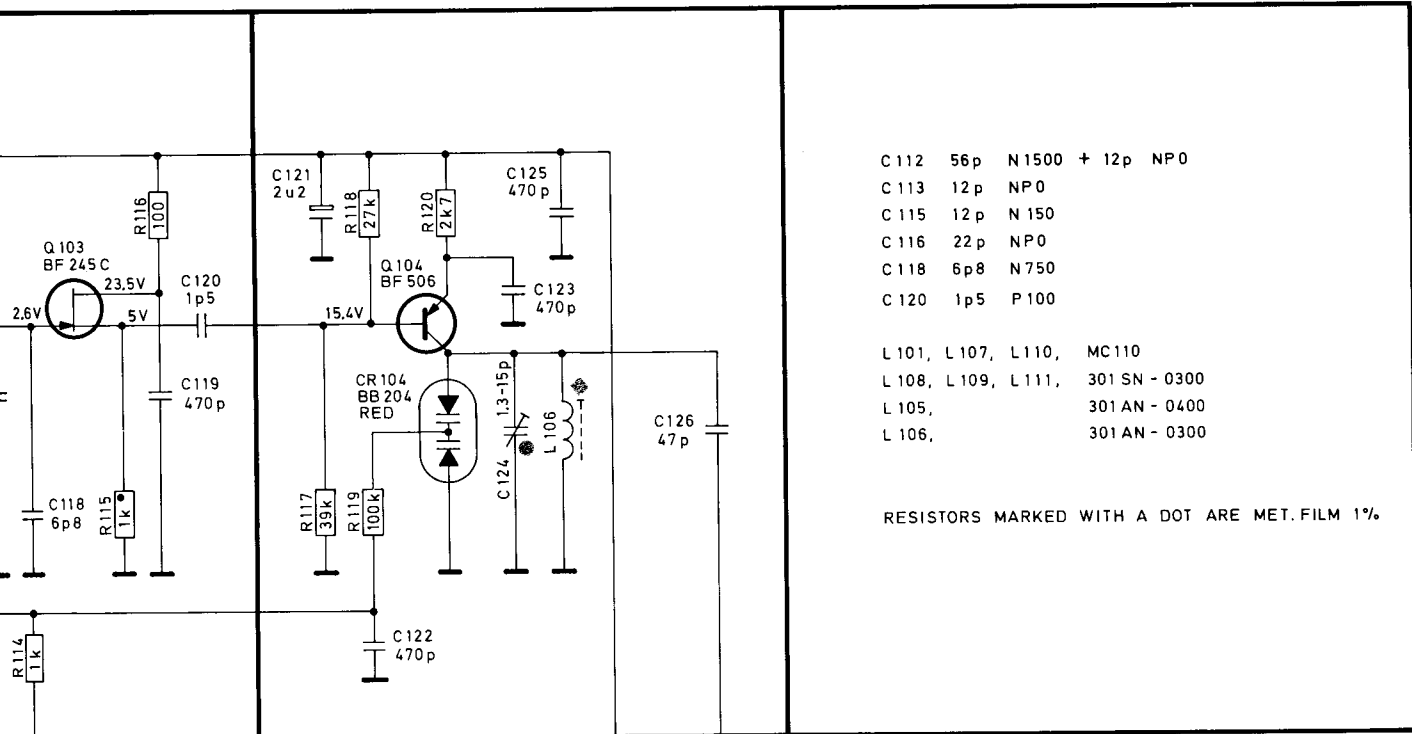

Figure 12 Front end



- C 112 56 p N 1500 + 12 p NP 0
- C 113 12 p NP 0
- C 115 12 p N 150
- C 116 22 p NP 0
- C 118 6 p 8 N 750
- C 120 1 p 5 P 100

- L 101, L 107, L 110, MC 110
- L 108, L 109, L 111, 301 SN - 0300
- L 105, 301 AN - 0400
- L 106, 301 AN - 0300

RESISTORS MARKED WITH A DOT ARE MET. FILM 1%

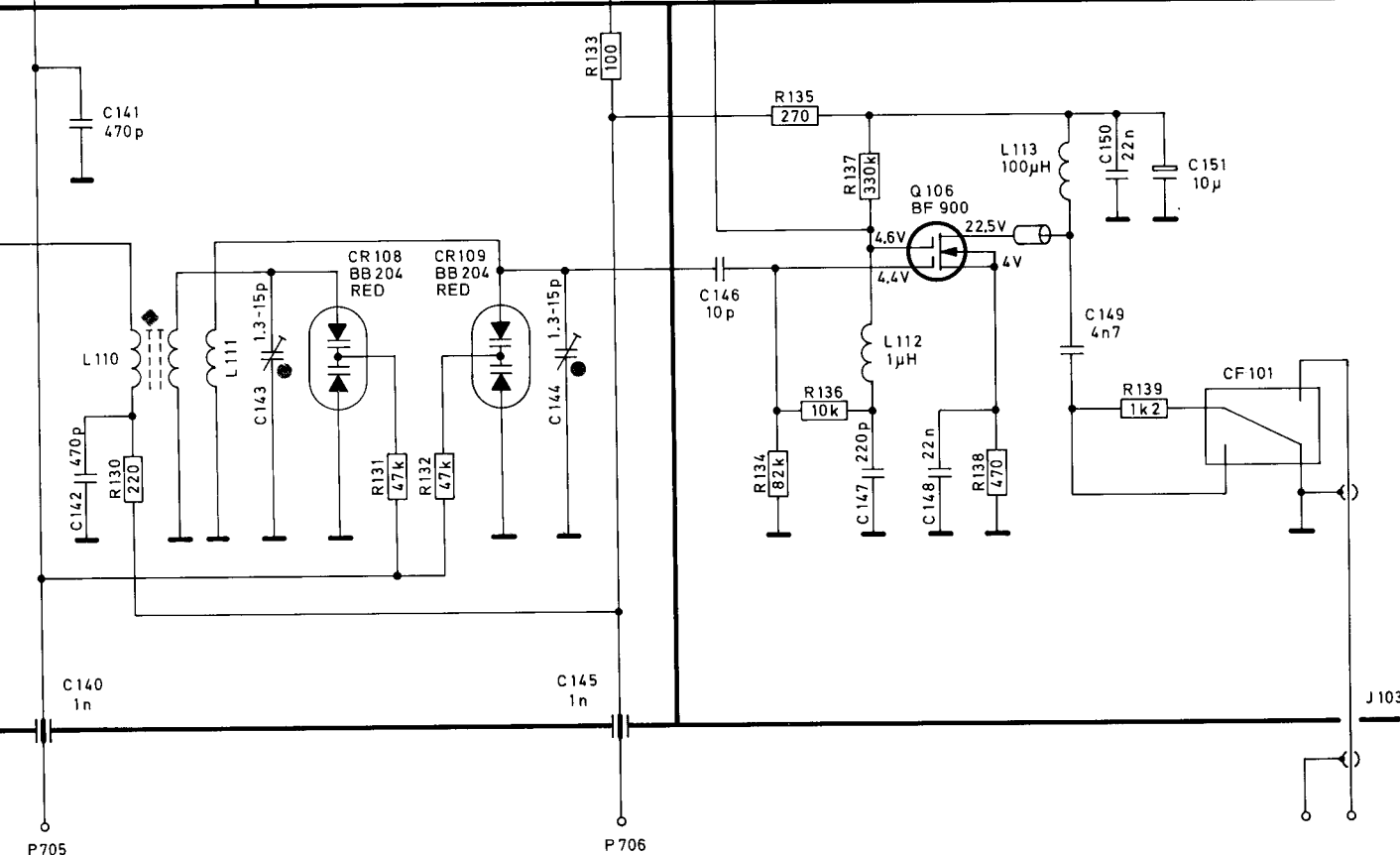

J 103

P 705

P 706

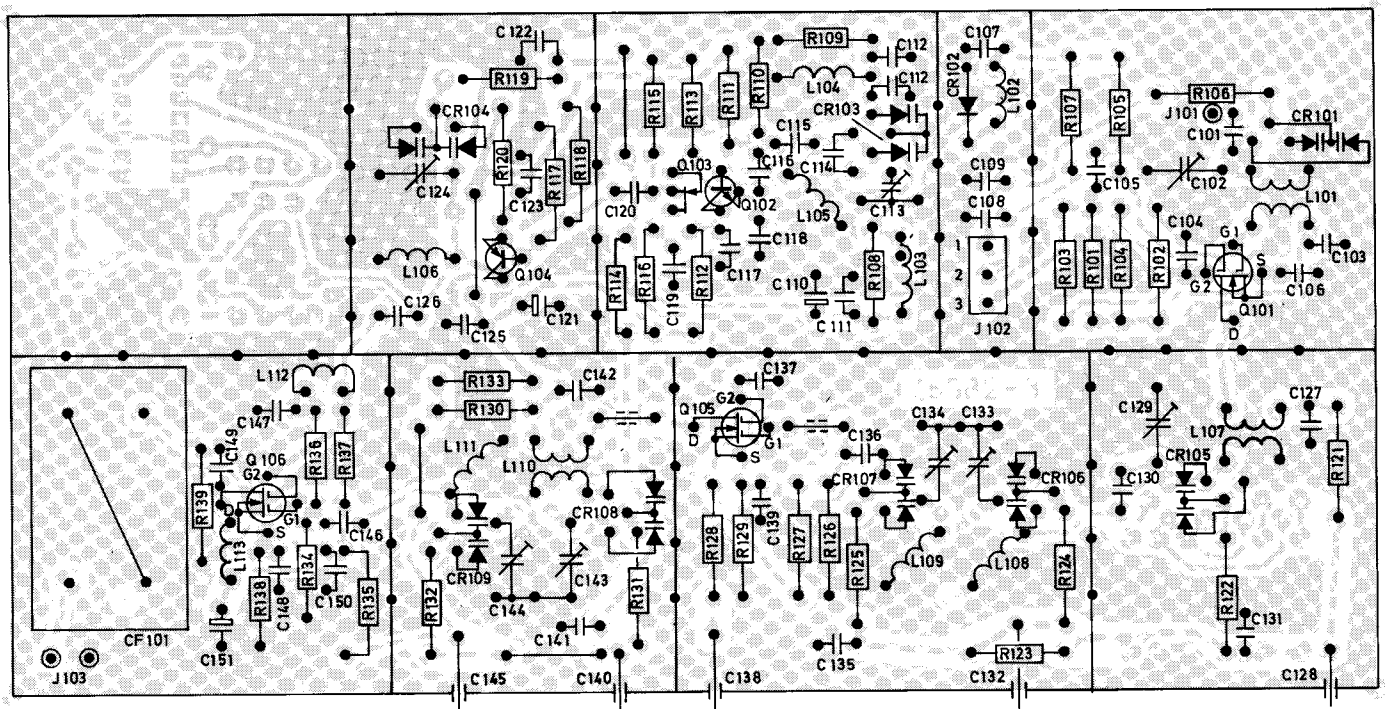

Figure 13 Front end board, foil side

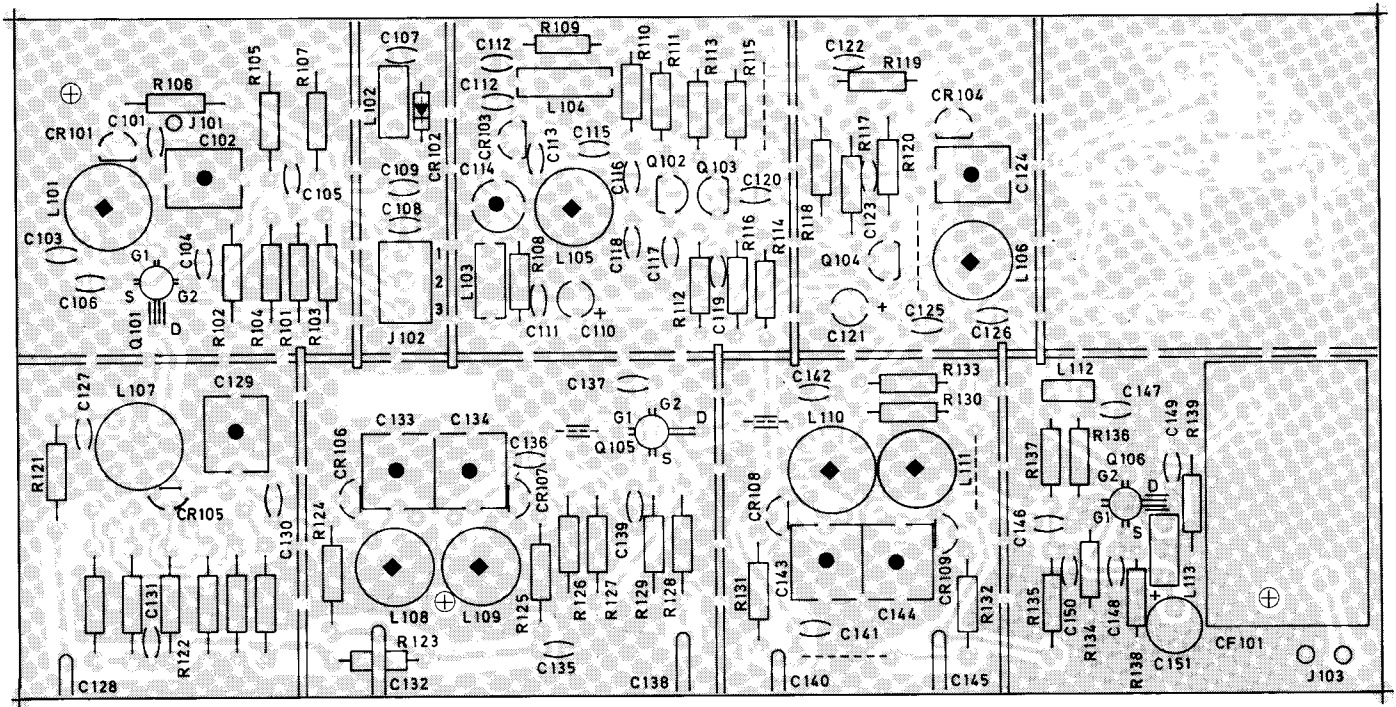

Figure 14 Front end board, component side

## Oscillator

- Connect signal generator to the antenna terminal, 0.5 mV/75 ohms,  $\pm 75$  kHz dev.
- Connect oscilloscope (a.c.-mode) to the FM-Multipath Vert. output at the rear of the tuner.
- Set the Bandwidth selector to Narrow.
- 90 MHz, adjust L105.  
105 MHz, adjust C114.

The cover must be on the Front End box during the oscillator adjustment.

- The center frequency is indicated by a symmetrical sinewave on the oscilloscope (figure 15).

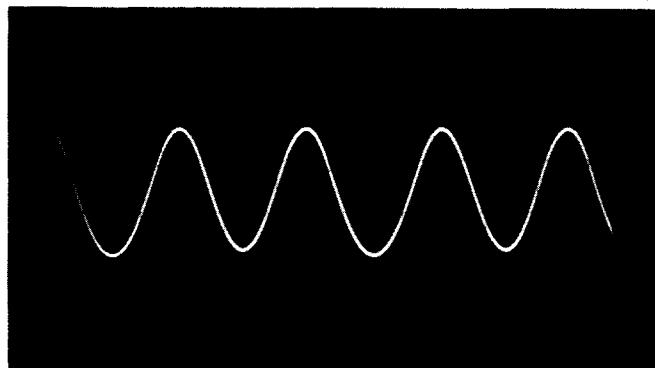

Figure 15 Symmetrical sinewave

## Front End

- Connect signal generator to the antenna terminal, 0.5 mV/75 ohms,  $\pm 75$  kHz dev.
- Connect oscilloscope (d.c.-mode) to the FM-Multipath Vert. output.
- Adjust to max. d.c. level on the oscilloscope. During the adjustment the curve will go to a maximum, then very slowly sink again. Adjust until no further maximum is obtainable.  
90 MHz: L101, L107, L108, L109, L110, L111, L106 (osc. amplitude).  
105 MHz: C102, C129, C133, C134, C143, C144, C124 (osc. amplitude).

To obtain a symmetrical curve, make a final adjustment with L105 (90 MHz) and C114 (105 MHz) in the oscillator circuit.



2.4 Limiter/Detector below serial No. 00700

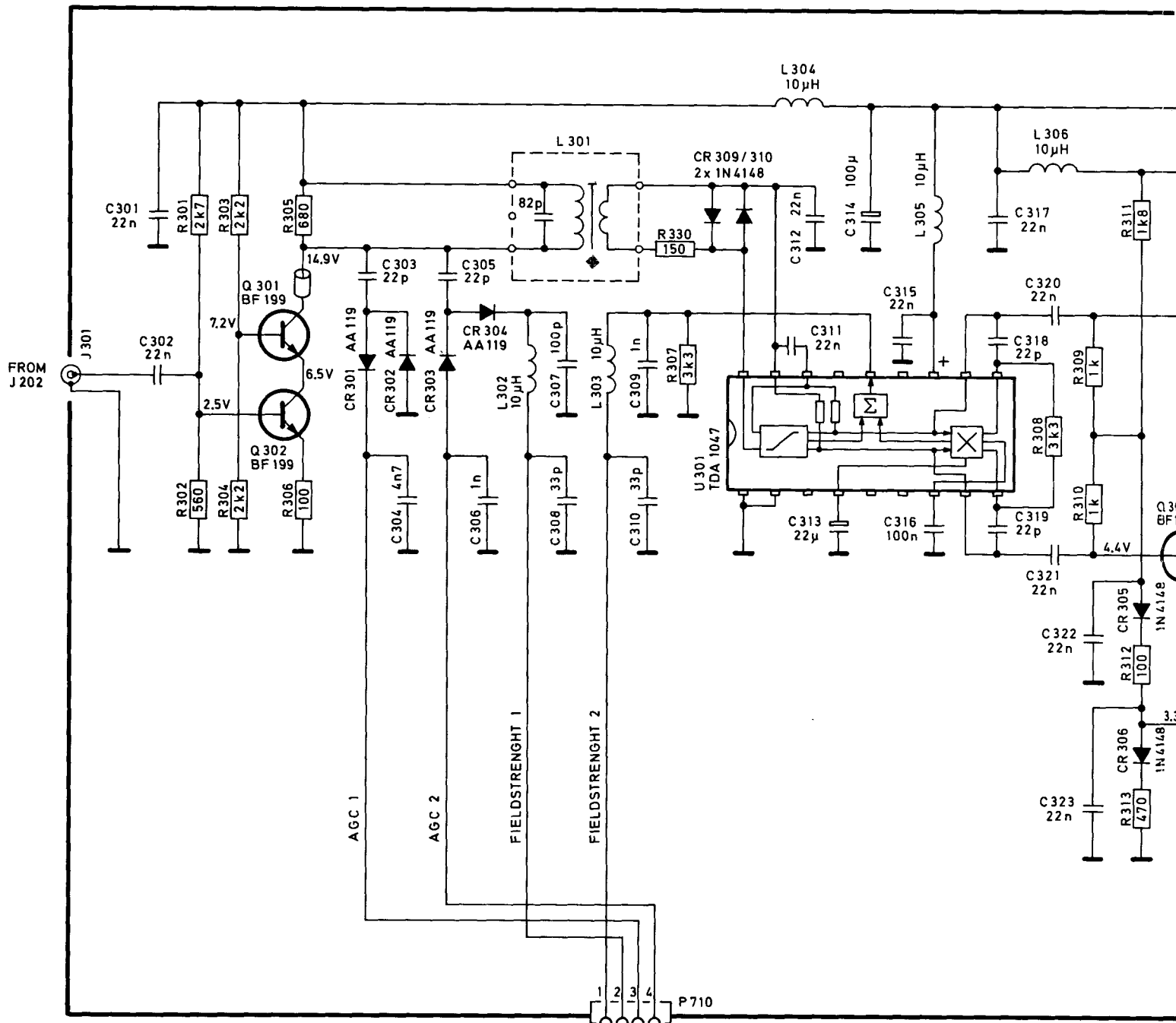
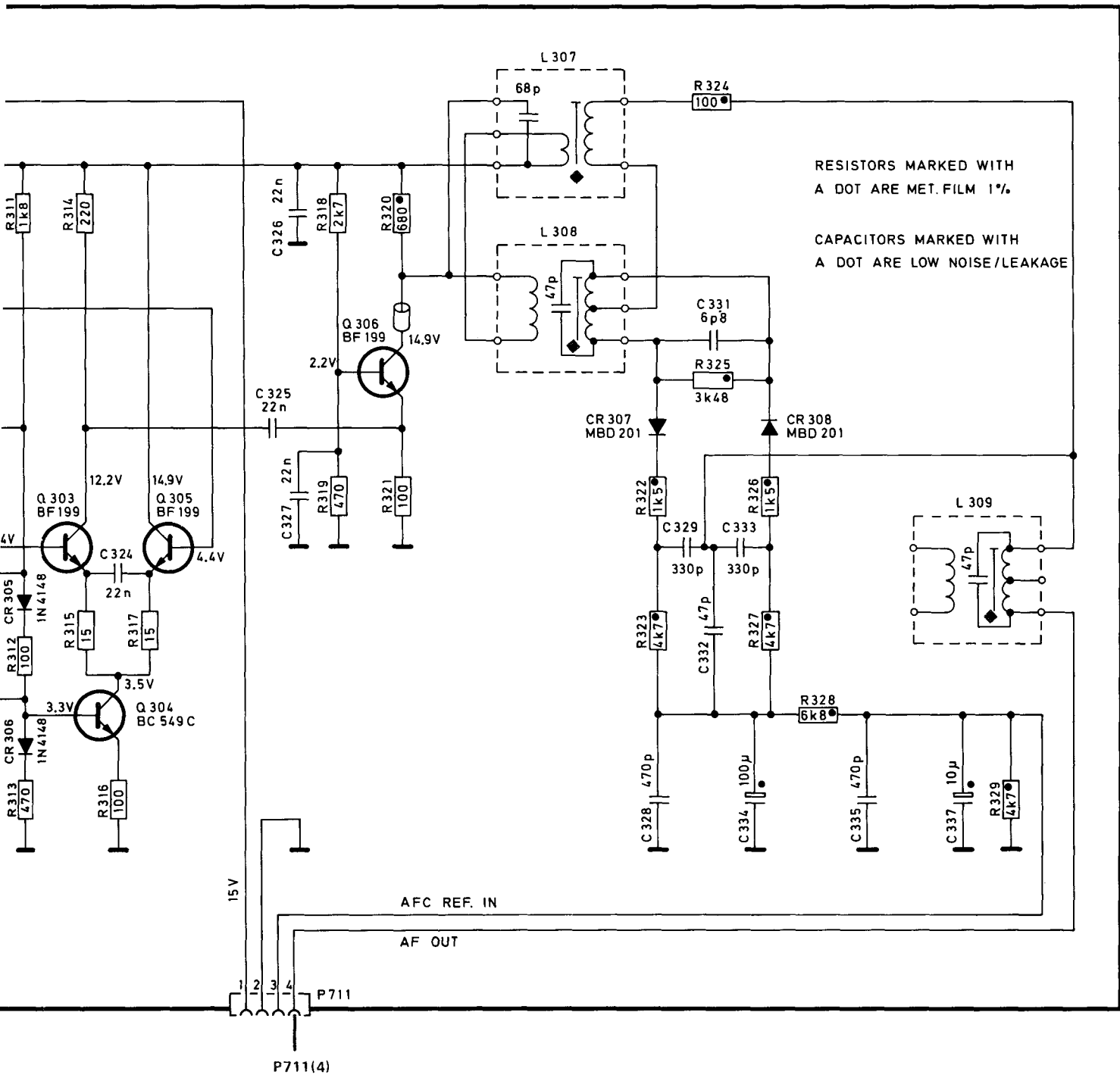

Figure 16 Limiter/detector below serial No. 00700



RESISTORS MARKED WITH  
A DOT ARE MET. FILM 1%.

CAPACITORS MARKED WITH  
A DOT ARE LOW NOISE/LEAKAGE

P711(4)

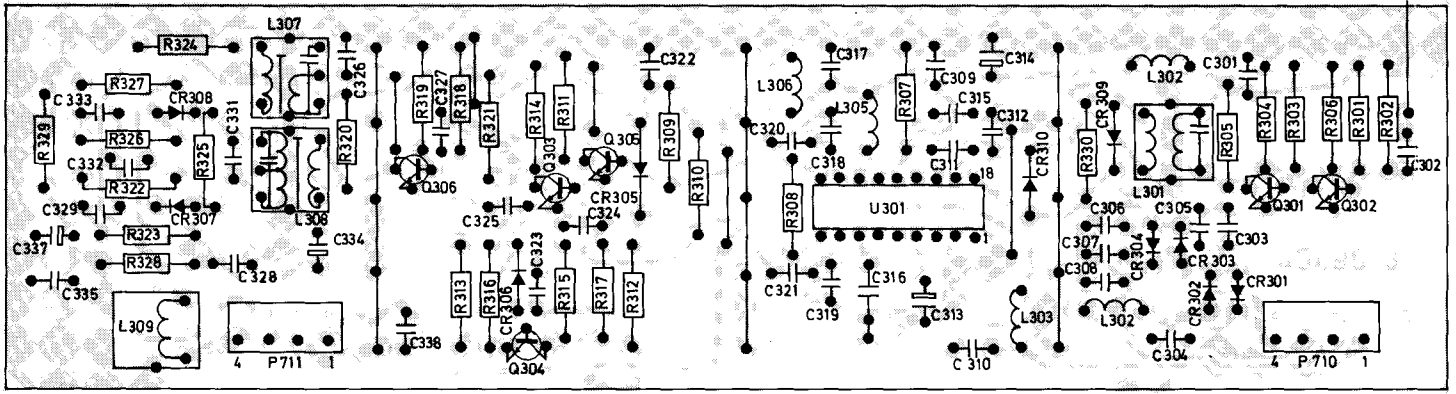

Figure 17 Limiter/detector board below serial No. 00700, foil side

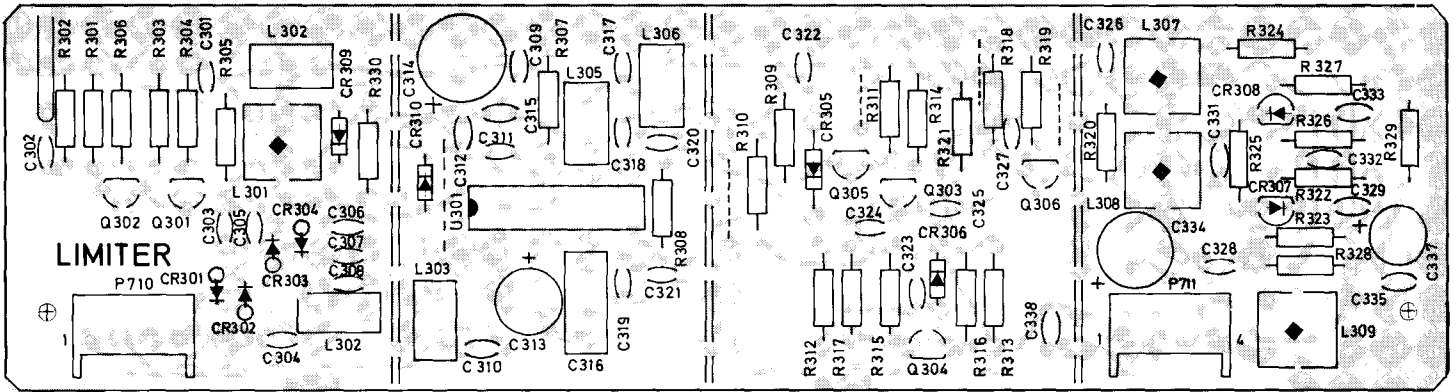

Figure 18 Limiter/detector board below serial No. 00700, component side

### Limiters/Detector, d.c.-reference and distortion

- Connect oscilloscope (d.c.-mode) to the FM-Multipath Vert. terminal.
- Pull out signal plug P201 on the selectivity box (see figure 19).
- Connect signal generator to J201 (see figure 19).

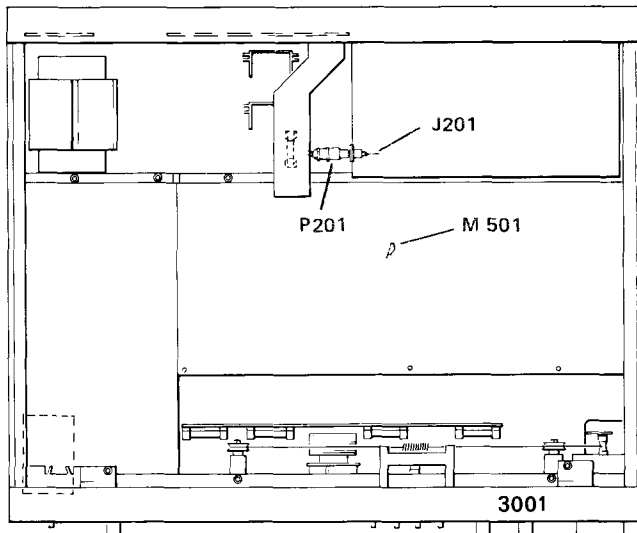

Figure 19 Test points

- Tune the generator to approx. 10.7 MHz, 500  $\mu$ V modulated mono  $\pm$  75 kHz dev., 1 kHz modulation.
- Set Bandwidth selector to Narrow.
- Fine-tune the generator for symmetrical sinewave on the oscilloscope (figure 20). The frequency thus found is now used for the further adjustments.

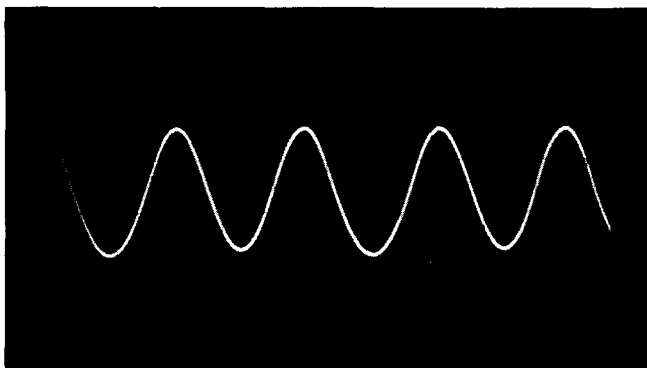

Figure 20 Symmetrical sinewave

- Switch off the modulation and set the generator output to 20 mV.
- Set Bandwidth selector to Wide.

- Pull out interconnector board No. 45430 (see figure 21).
- Connect a d.c. millivoltmeter (range 100 mV) to P711, pin 4 (strap next to R786 on the main board, see figure 21).
- Shortcircuit the strap to ground for a second.

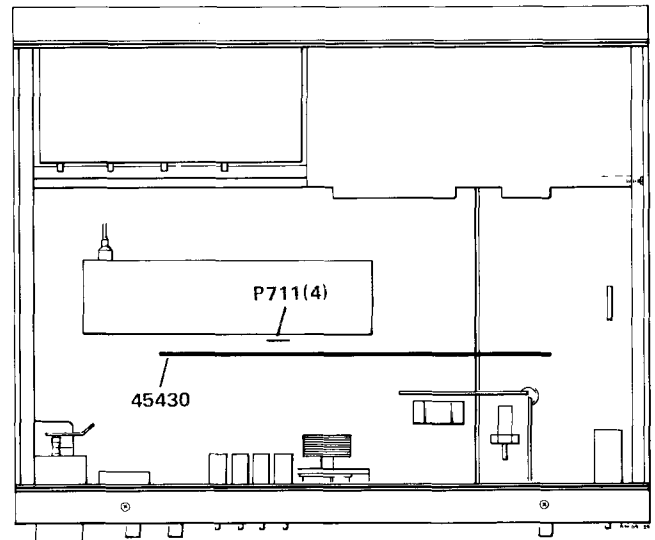

Figure 21 Test points

- Adjust L308 for slightly less than 5 mV reading on the millivoltmeter.
- Connect an oscilloscope (a.c.-mode, 5 mV) to M501 on the decoder board (see figure 19).
- Adjust L309 for minimum 10.7 MHz on the oscilloscope.
- Put back interconnection board No. 45430 (see figure 21).
- Set the generator modulation to  $\pm$  75 kHz, 20 mV.
- Connect distortion meter to one of the Fixed Output terminals.
- Adjust L307 for minimum distortion, typical figure 0.006%.
- Check the other channel.
- Reduce the signal level to approx. 5  $\mu$ V.
- Connect the oscilloscope to one of the Fixed Output terminals.
- Adjust L301 for as clean and distortionfree sinewave as possible. Start from an inner position and screw the core outwards.
- Put back the signal plug P201 on the selectivity box (see figure 19).

2.5 Limiter/Detector above serial No. 00700

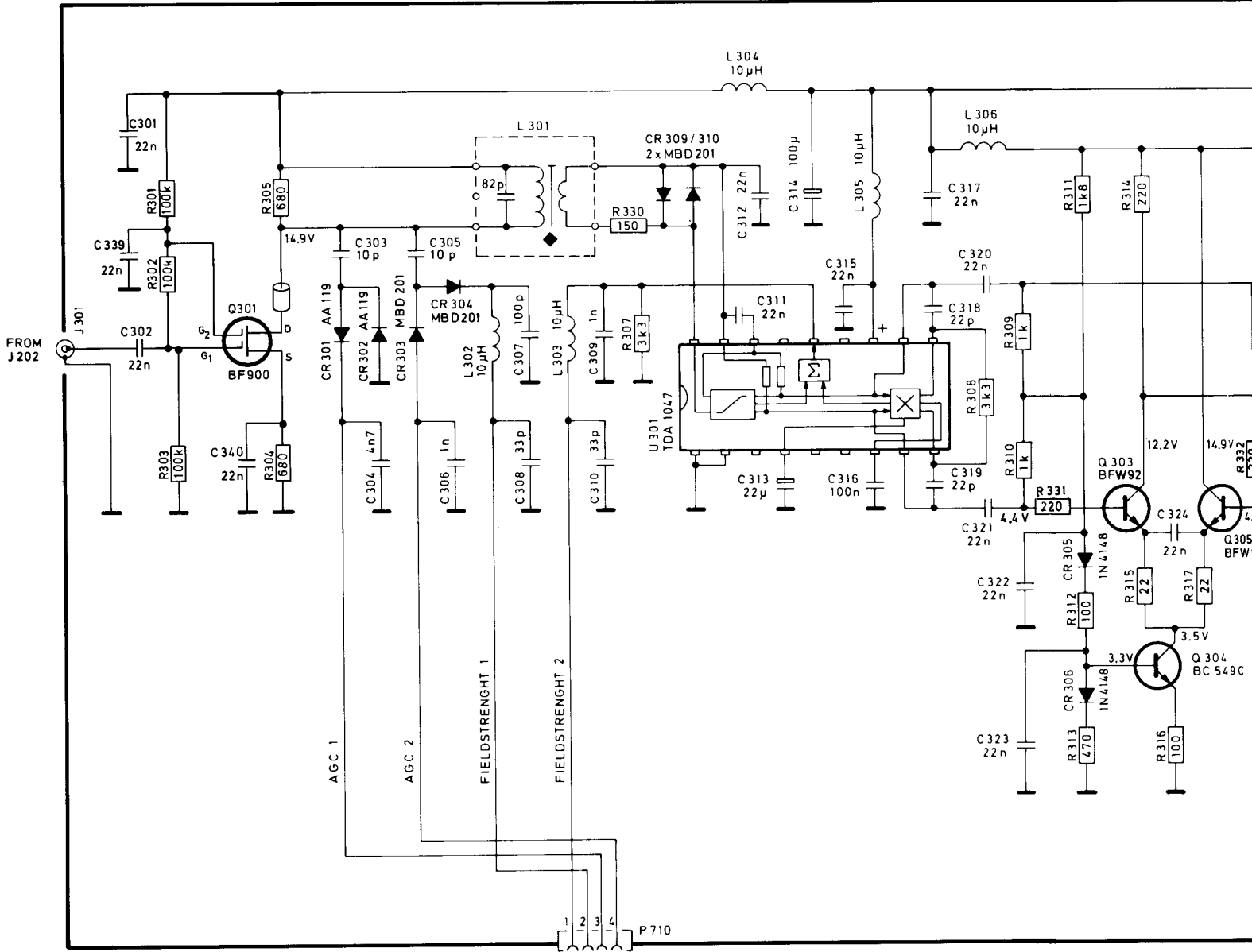
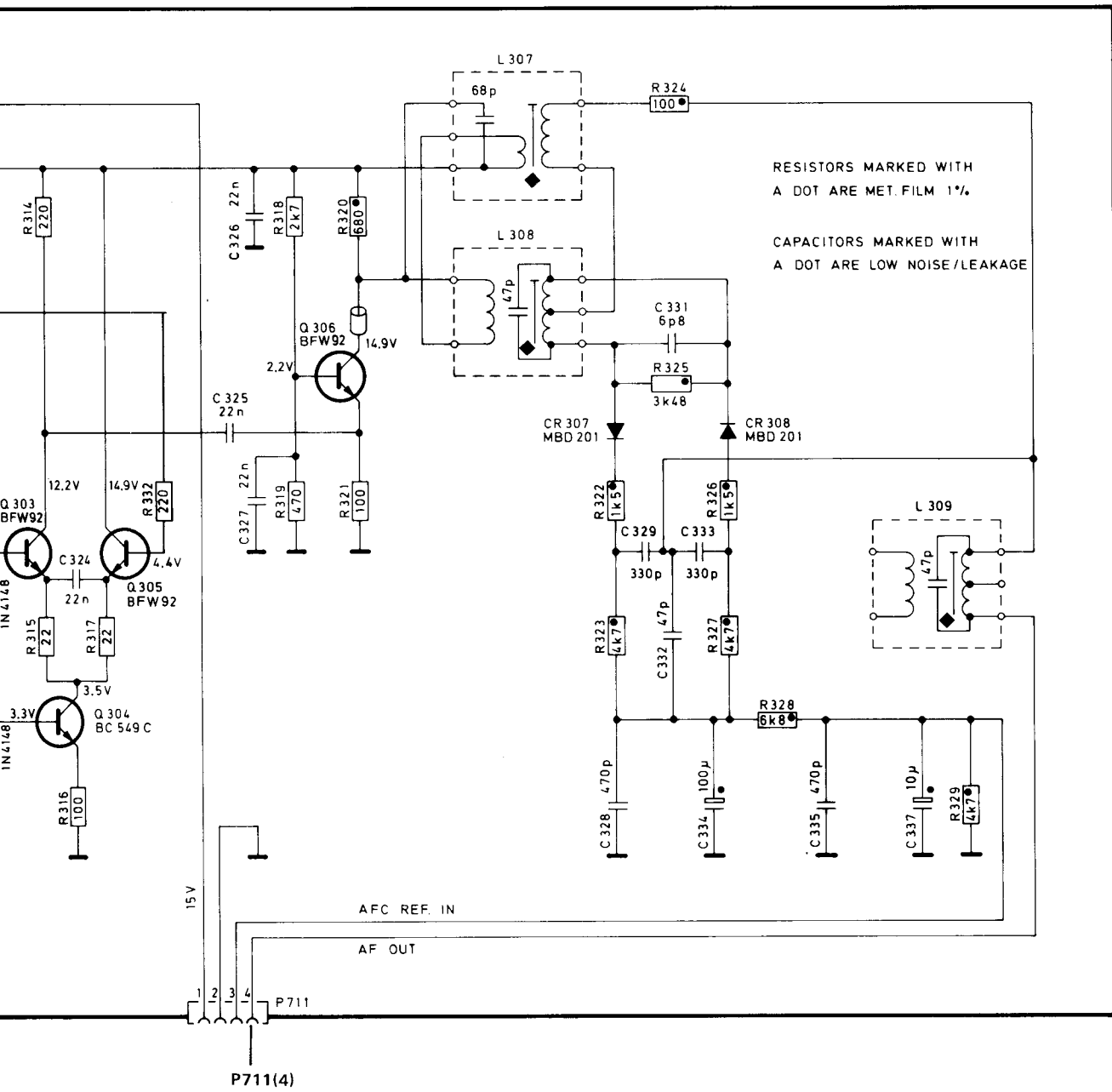

Figure 22 Limiter/detector above serial No. 00700



RESISTORS MARKED WITH  
A DOT ARE MET. FILM 1%.

CAPACITORS MARKED WITH  
A DOT ARE LOW NOISE/LEAKAGE

P711(4)

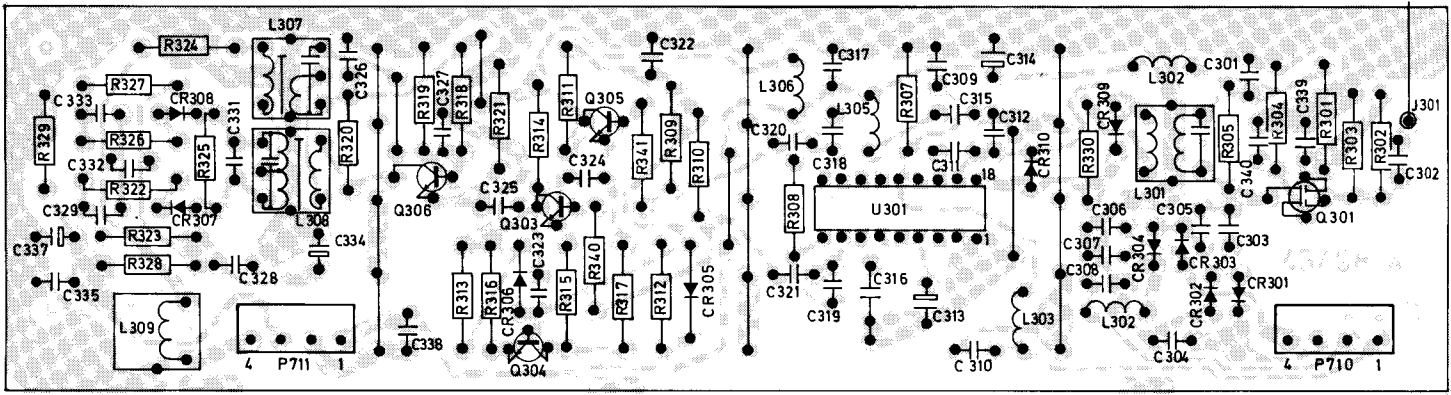

Figure 23 Limiter/detector board above serial No. 00700, foil side

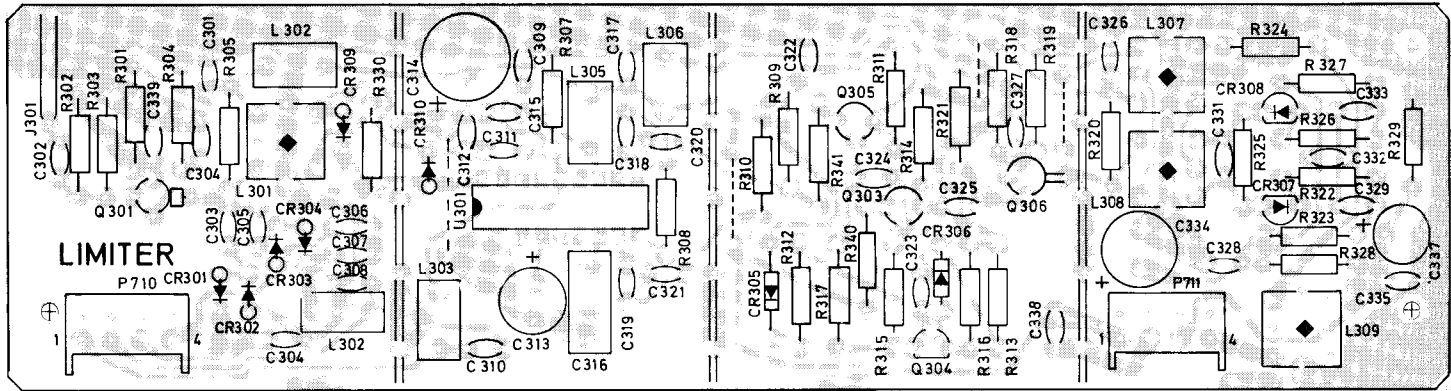

Figure 24 Limiter/detector board above serial No. 00700, component side

### Limiter/Detector, d.c.-reference and distortion

- Connect oscilloscope (d.c.-mode) to the FM-Multipath Vert. terminal.
- Pull out signal plug P201 on the selectivity box (see figure 25).
- Connect signal generator to J201 (see figure 25).

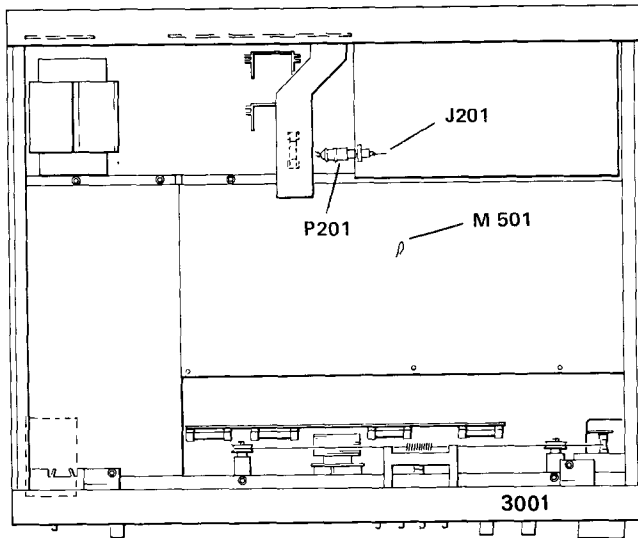

Figure 25 Test points

- Tune the generator to approx. 10.7 MHz, 500  $\mu$ V modulated mono  $\pm$  75 kHz dev., 1 kHz modulation.
- Set Bandwidth selector to Narrow.
- Fine-tune the generator for symmetrical sinewave on the oscilloscope (figure 26). The frequency thus found is now used for the further adjustments.

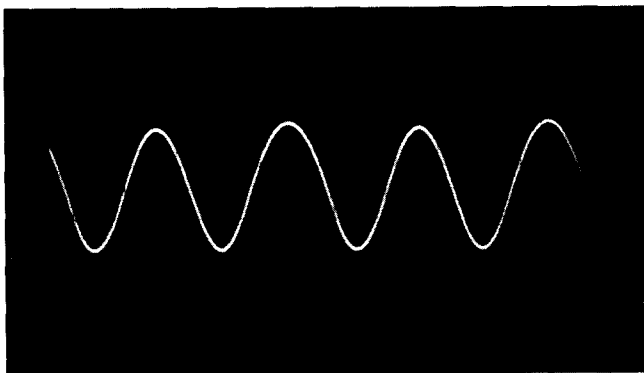

Figure 26 Symmetrical sinewave

- Switch off the modulation and set the generator output to 20 mV.
- Set Bandwidth selector to Wide.

- Pull out interconnector board No. 45430 (see figure 27).
- Connect a d.c. millivoltmeter (range 100 mV) to P711, pin 4 (strap next to R786 on the main board, see figure 27).
- Shortcircuit the strap to ground for a second.

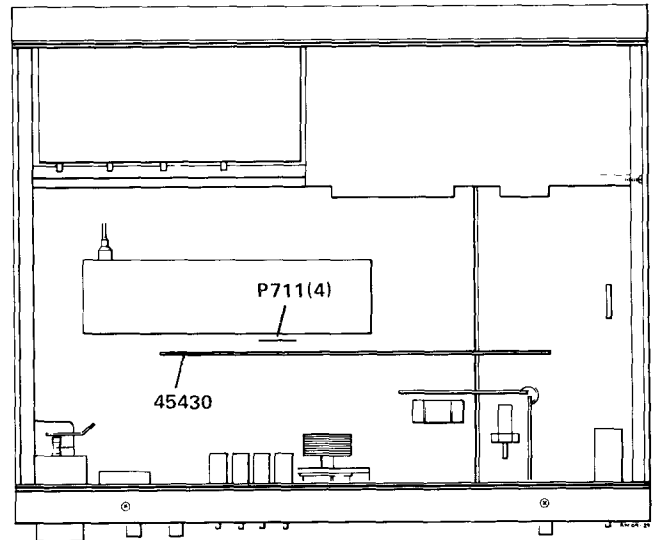

Figure 27 Test points

- Adjust L308 for slightly less than 5 mV reading on the millivoltmeter.
- Connect an oscilloscope (a.c.-mode, 5 mV) to M501 on the decoder board (see figure 25).
- Adjust L309 for minimum 10.7 MHz on the oscilloscope.
- Put back interconnection board No. 45430 (see figure 27).
- Set the generator modulation to  $\pm$  75 kHz, 20 mV.
- Connect distortion meter to one of the Fixed Output terminals.
- Adjust L307 for minimum distortion, typical figure 0.006%.
- Check the other channel.
- Reduce the signal level to approx. 5  $\mu$ V.
- Connect the oscilloscope to one of the Fixed Output terminals.
- Adjust L301 for as clean and distortionfree sinewave as possible. Start from an inner position and screw the core outwards.
- Put back the signal plug P201 on the selectivity box (see figure 25).



2.6 Selectivity below serial No. 00700

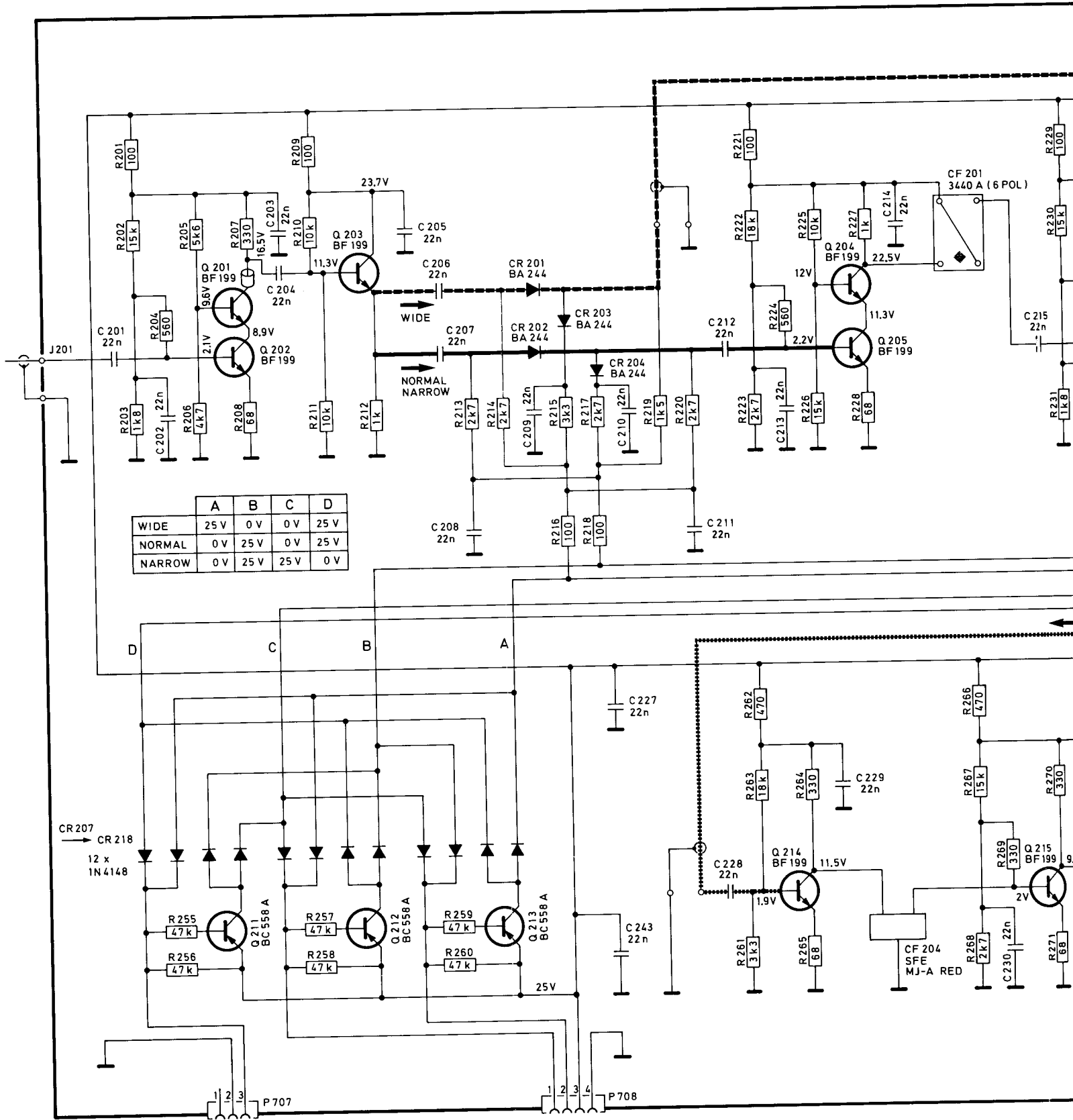
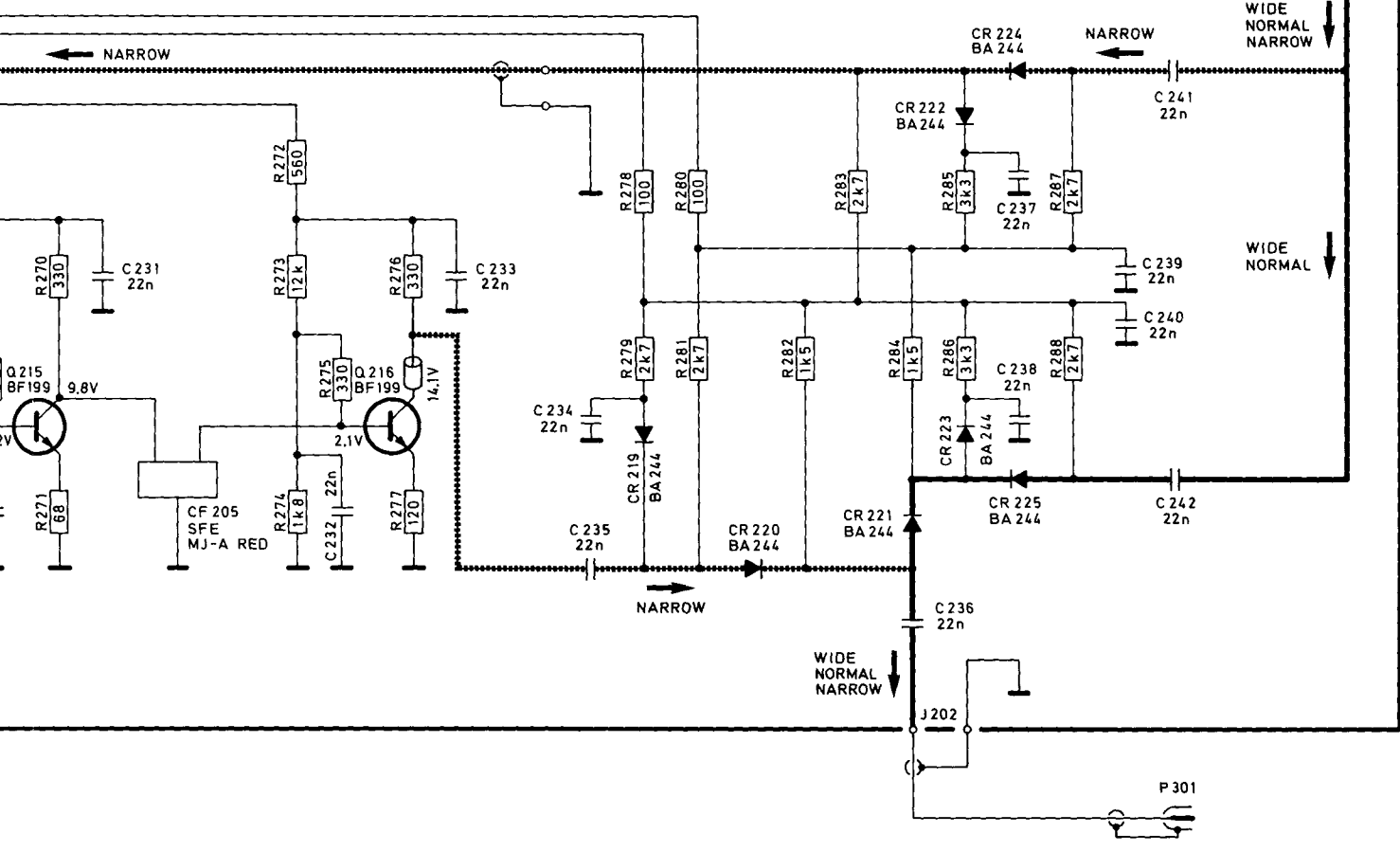
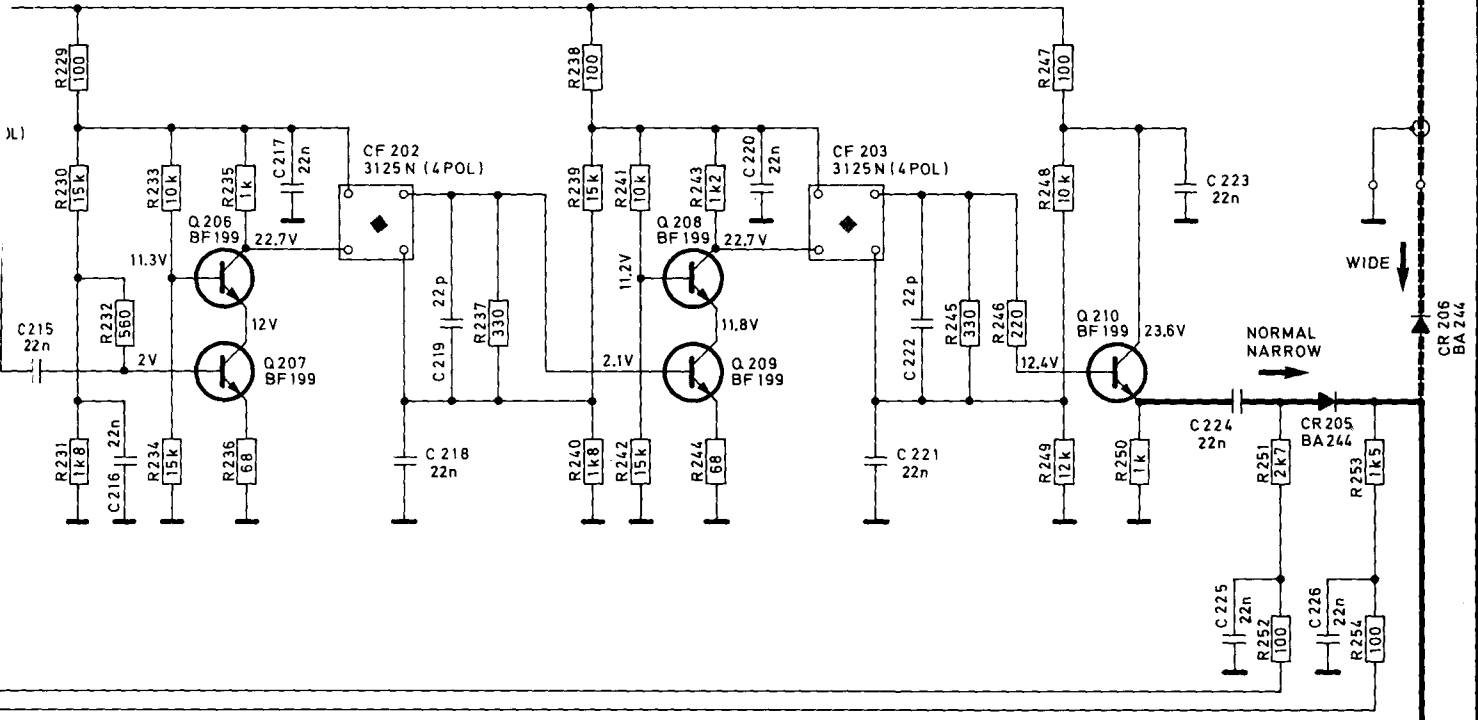

Figure 28 Selectivity circuit, below serial No. 00700

WIDE



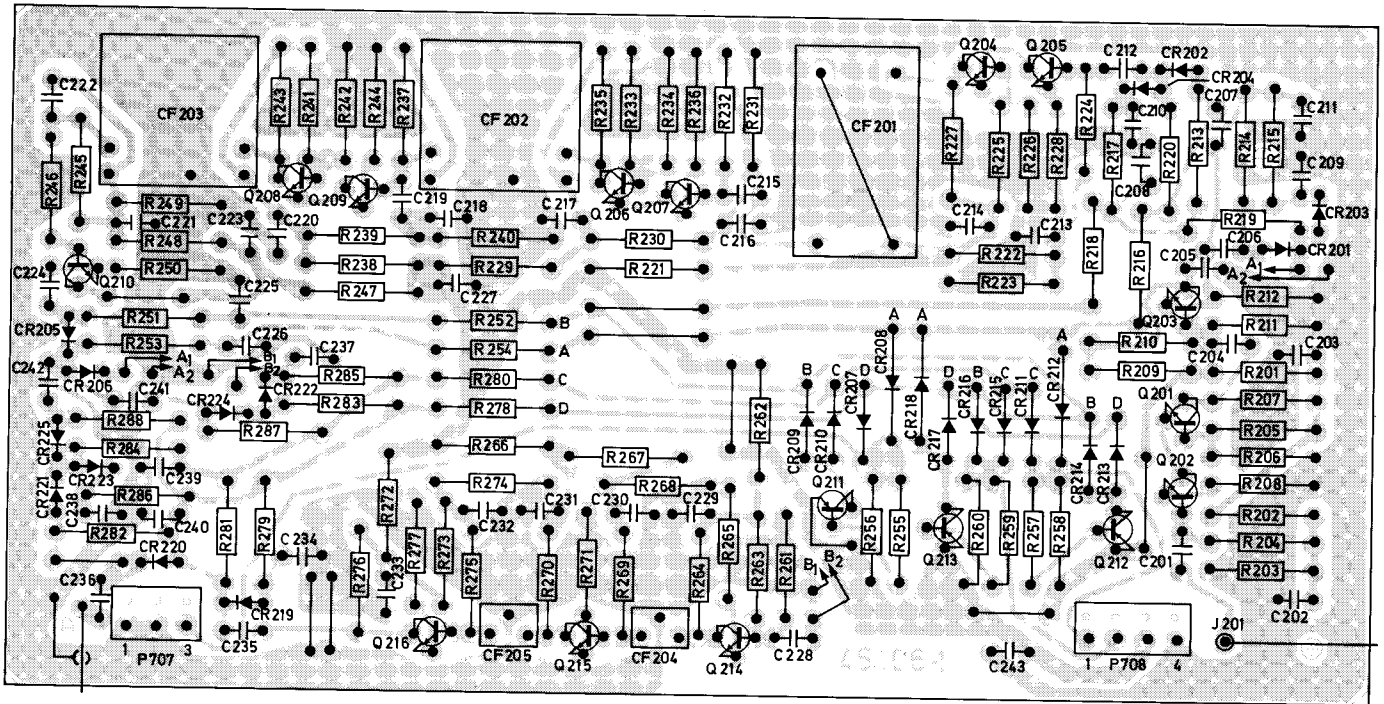

Figure 29 Selectivity board below serial No. 00700, foil side

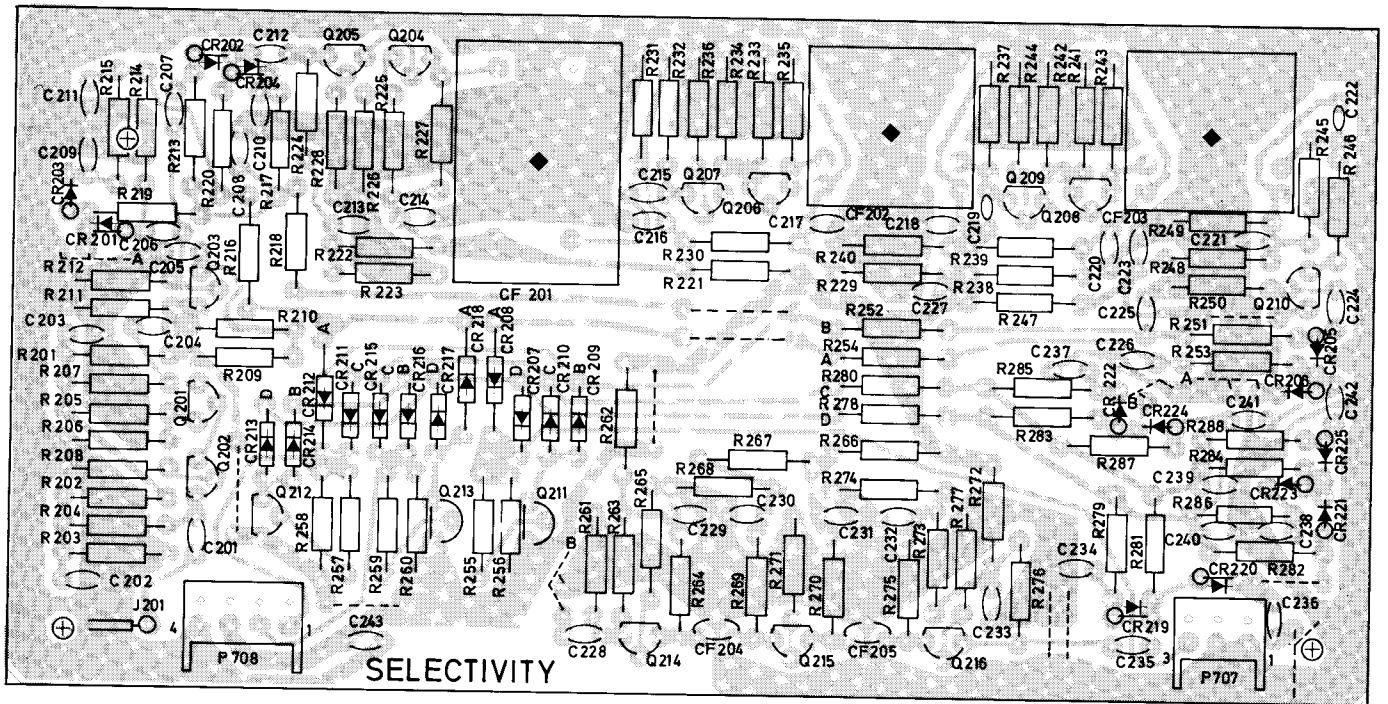

Figure 30 Selectivity board below serial No. 00700, component side

### Distortion in Wide position (6-pole filter)

- Connect signal generator to the antenna input, 98 MHz, 0.5 mV/75 ohms. Right channel modulated in stereo  $\pm 75$  kHz, 10% pilot tone.
- Connect oscilloscope (d.c.-mode) to the FM Multipath Vert. terminal.
- Set Bandwidth selector to Narrow.
- Fine-tune the tuner for symmetrical sinewave on the oscilloscope (see figure 31).

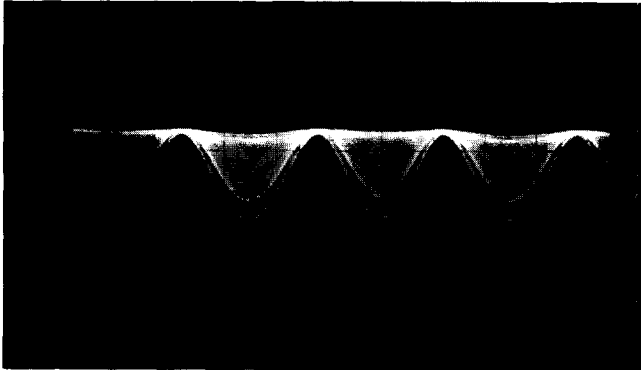

Figure 31 Symmetrical sinewave

- Connect distortion meter to Fixed Output R.
- Set Bandwidth selector to Wide.
- Adjust CF101 (Front End, figure 32) for minimum distortion (on the distortion meter) and at the same time maximum d.c.-level and symmetrical sinewave on the oscilloscope (see figure 31).
- Check in mono to obtain best result in mono as well as in stereo. Distortion limit 0.04%.
- Be aware that a correct adjustment of the front end circuits is essential to obtain the distortion limit figure.

### Distortion in Normal

- Connect signal generator to the antenna terminal, 98 MHz, 0.5 mV/75 ohms. Right channel modulated in stereo.  $\pm 75$  kHz, 10% pilot tone.
- Connect oscilloscope (d.c.-mode) to the FM-Multipath Vert. terminal.
- Connect distortion meter to Fixed Output R.
- Set Bandwidth selector to Normal.
- Adjust CF201, CF202, CF203 for minimum distortion. Tolerance  $\leq 0.05\%$ .
- Check distortion in mono. Limit 0.06%.

### AGC

- Connections as described above.
- Set signal generator to mono.
- Screw R708 fully counterclockwise (see figure 32).
- Increase the signal level until the distortion reaches 0.1%.
- Adjust R708 until the distortion falls to 0.05%.
- Connect voltmeter to R702 (see figure 32).
- The voltage at R702 should be 20 V with no AGC-regulation and fall when regulation starts.
- Check that regulation does not start before the generator signal level exceeds 0.5 mV.

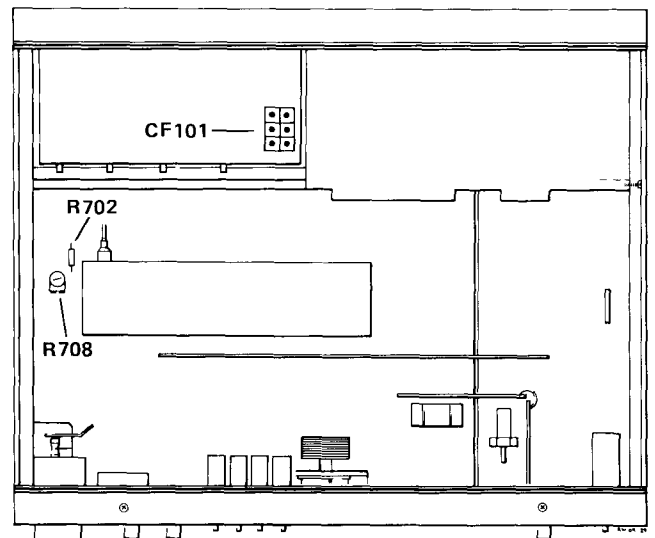

Figure 32 Test points

2.7 Selectivity above serial No. 00700

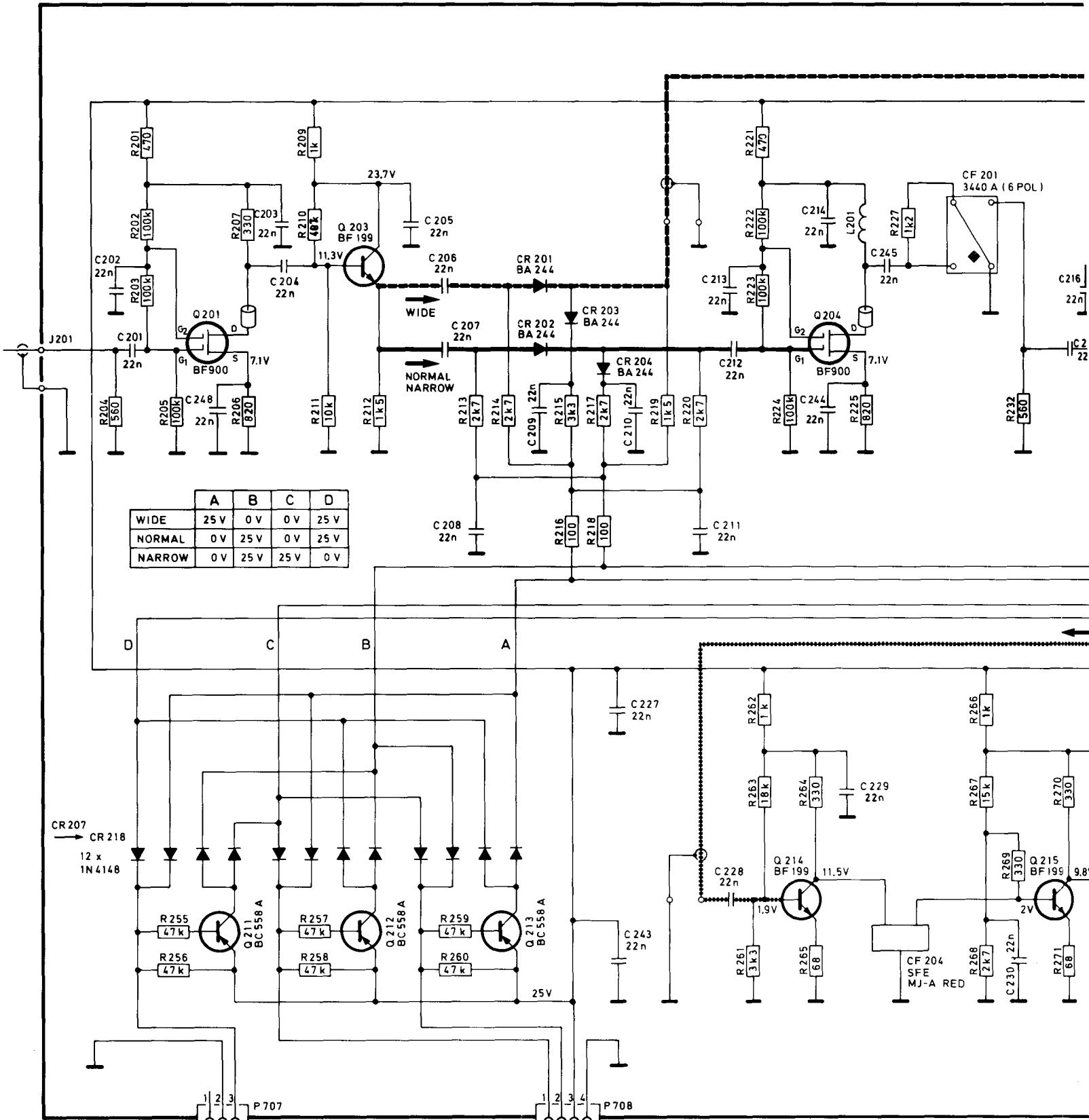
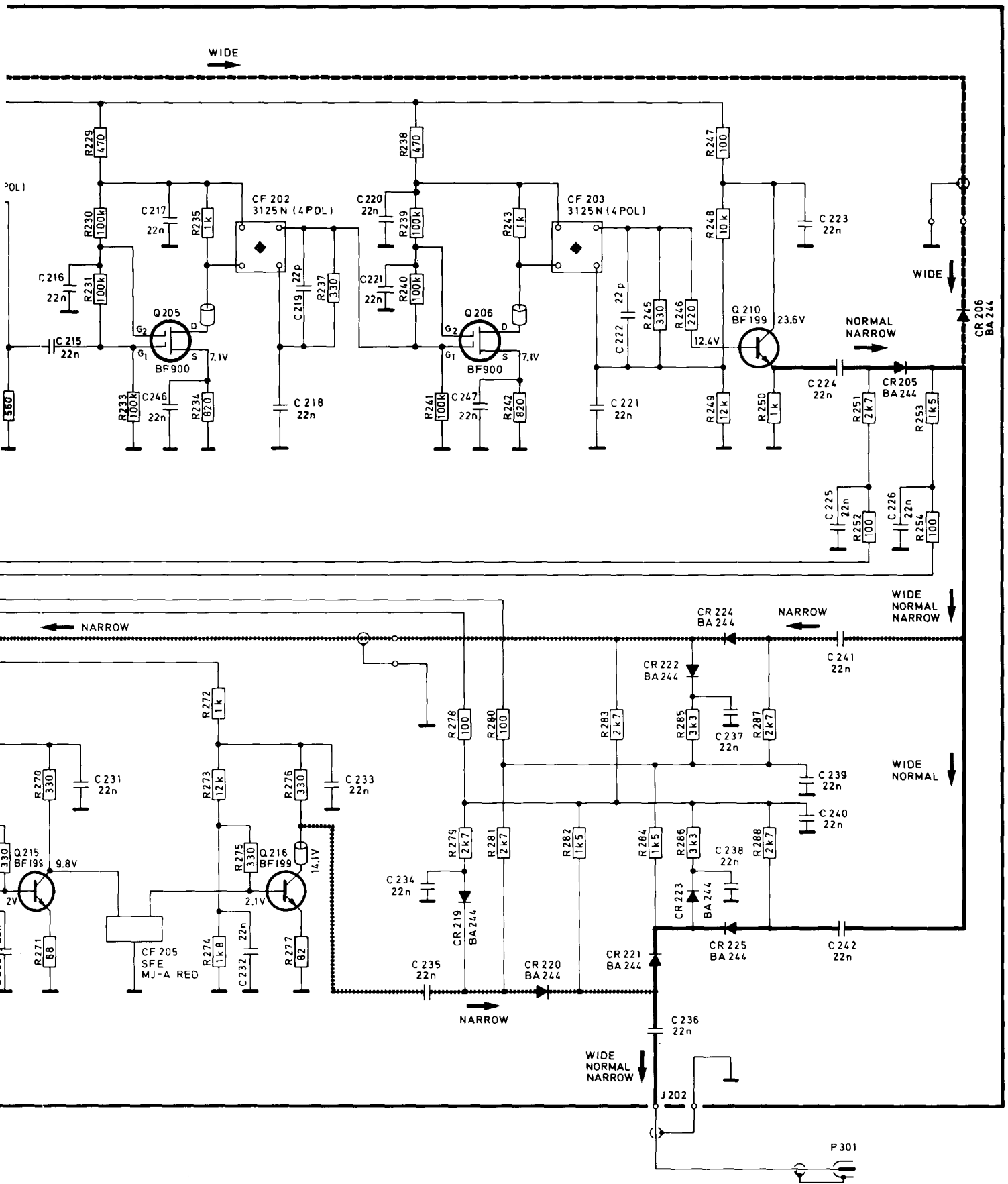

Figure 33 Selectivity circuit, above serial No. 00700



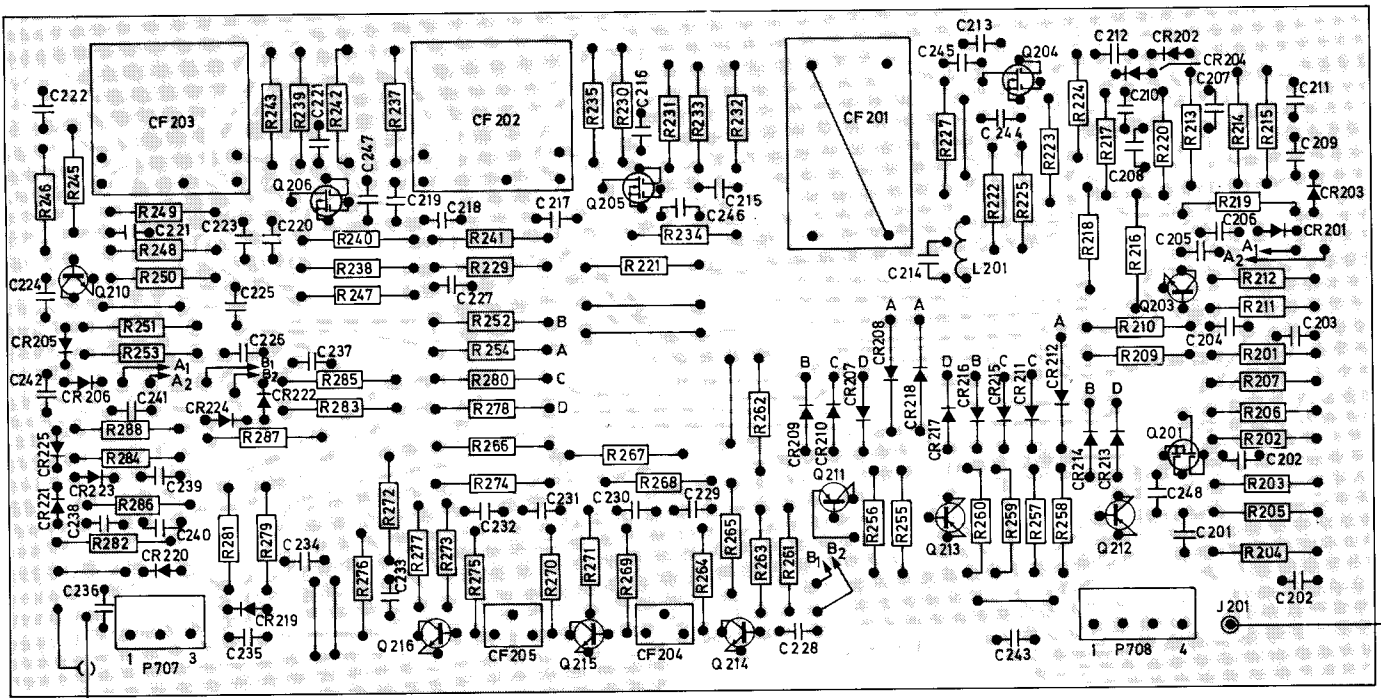

Figure 34 Selectivity board above serial No. 00700, foil side

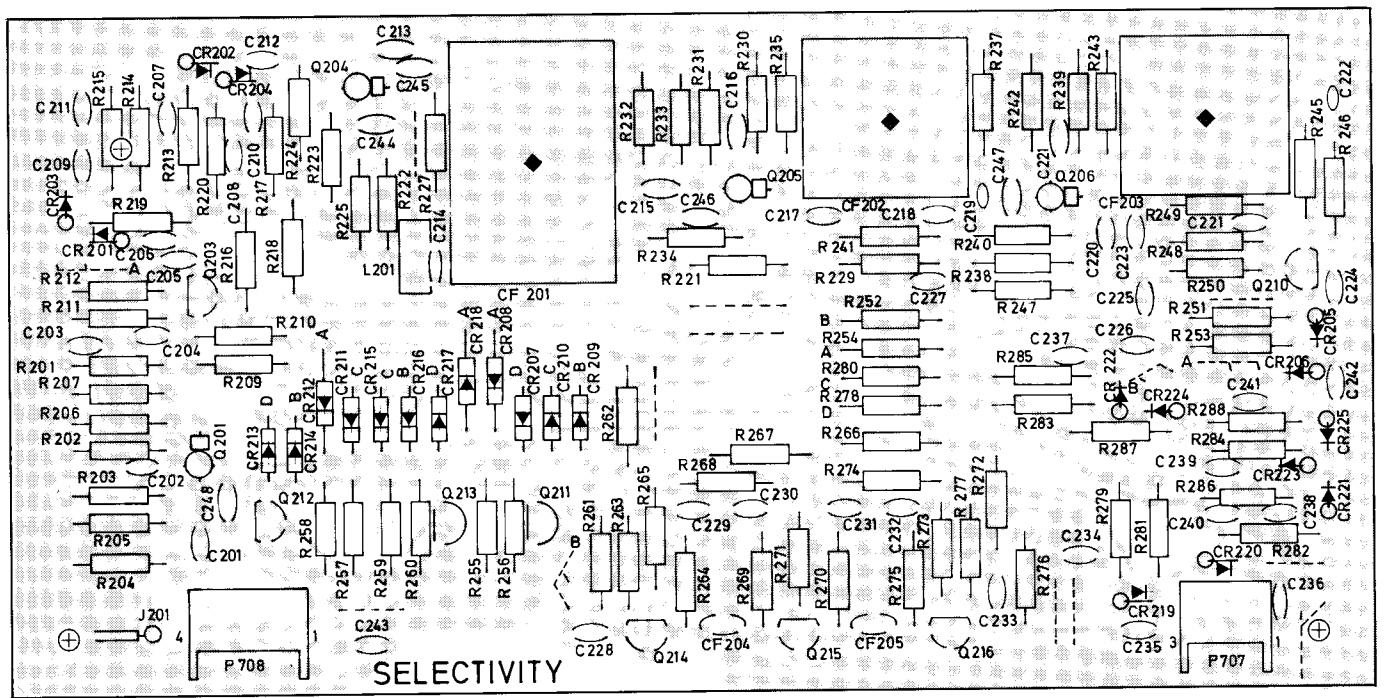

Figure 35 Selectivity board above serial No. 00700, component side

### Distortion in Wide position (6-pole filter)

- Connect signal generator to the antenna input, 98 MHz, 0.5 mV/75 ohms. Right channel modulated in stereo  $\pm 75$  kHz, 10% pilot tone.
- Connect oscilloscope (d.c.-mode) to the FM Multipath Vert. terminal.
- Set Bandwidth selector to Narrow.
- Fine-tune the tuner for symmetrical sinewave on the oscilloscope (see figure 36).

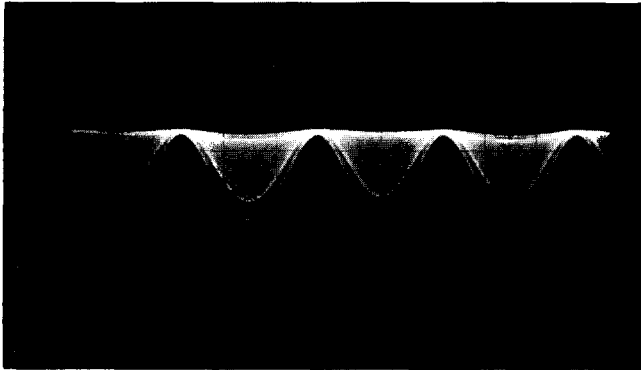

Figure 36 Symmetrical sinewave

- Connect distortion meter to Fixed Output R.
- Set Bandwidth selector to Wide.
- Adjust CF101 (Front End, figure 37) for minimum distortion (on the distortion meter) and at the same time maximum d.c.-level and symmetrical sinewave on the oscilloscope (see figure 36).
- Check in mono to obtain best result in mono as well as in stereo. Distortion limit 0.04%.
- Be aware that a correct adjustment of the front end circuits is essential to obtain the distortion limit figure.

### Distortion in Normal

- Connect signal generator to the antenna terminal, 98 MHz, 0.5 mV/75 ohms. Right channel modulated in stereo.  $\pm 75$  kHz, 10% pilot tone.
- Connect oscilloscope (d.c.-mode) to the FM-Multipath Vert. terminal.
- Connect distortion meter to Fixed Output R.
- Set Bandwidth selector to Normal.
- Adjust CF201, CF202, CF203 for minimum distortion. Tolerance  $\leq 0.05\%$ .
- Check distortion in mono. Limit 0.06%.

### AGC

- Connections as described above.
- Set signal generator to mono.
- Screw R708 fully counterclockwise (see figure 37).
- Increase the signal level until the distortion reaches 0.1%.
- Adjust R708 until the distortion falls to 0.05%.
- Connect voltmeter to R702 (see figure 37).
- The voltage at R702 should be 20 V with no AGC-regulation and fall when regulation starts.
- Check that regulation does not start before the generator signal level exceeds 0.5 mV.

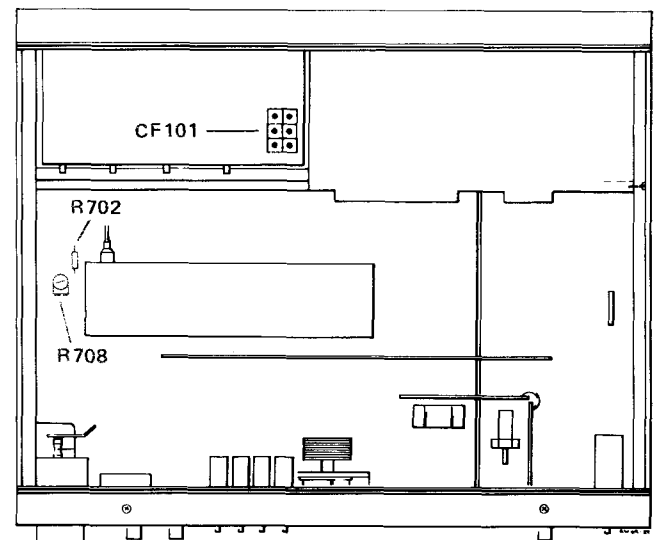

Figure 37 Test points



## 2.8 Signal meter, muting level

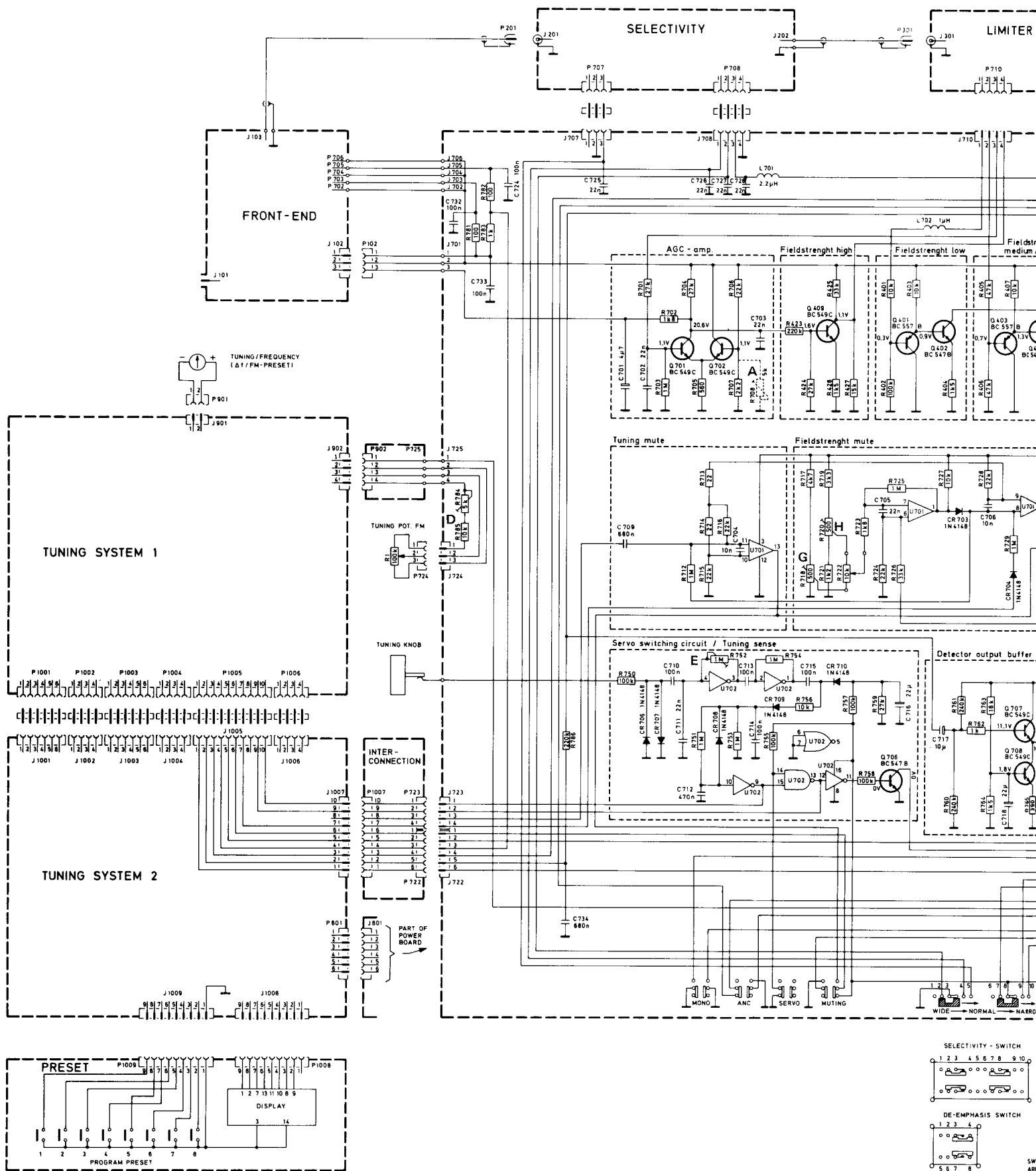
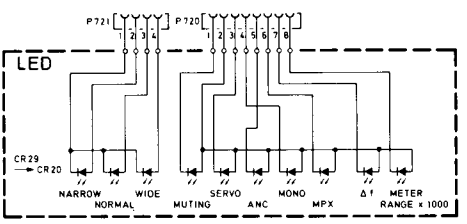
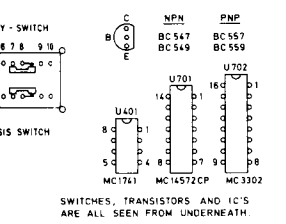
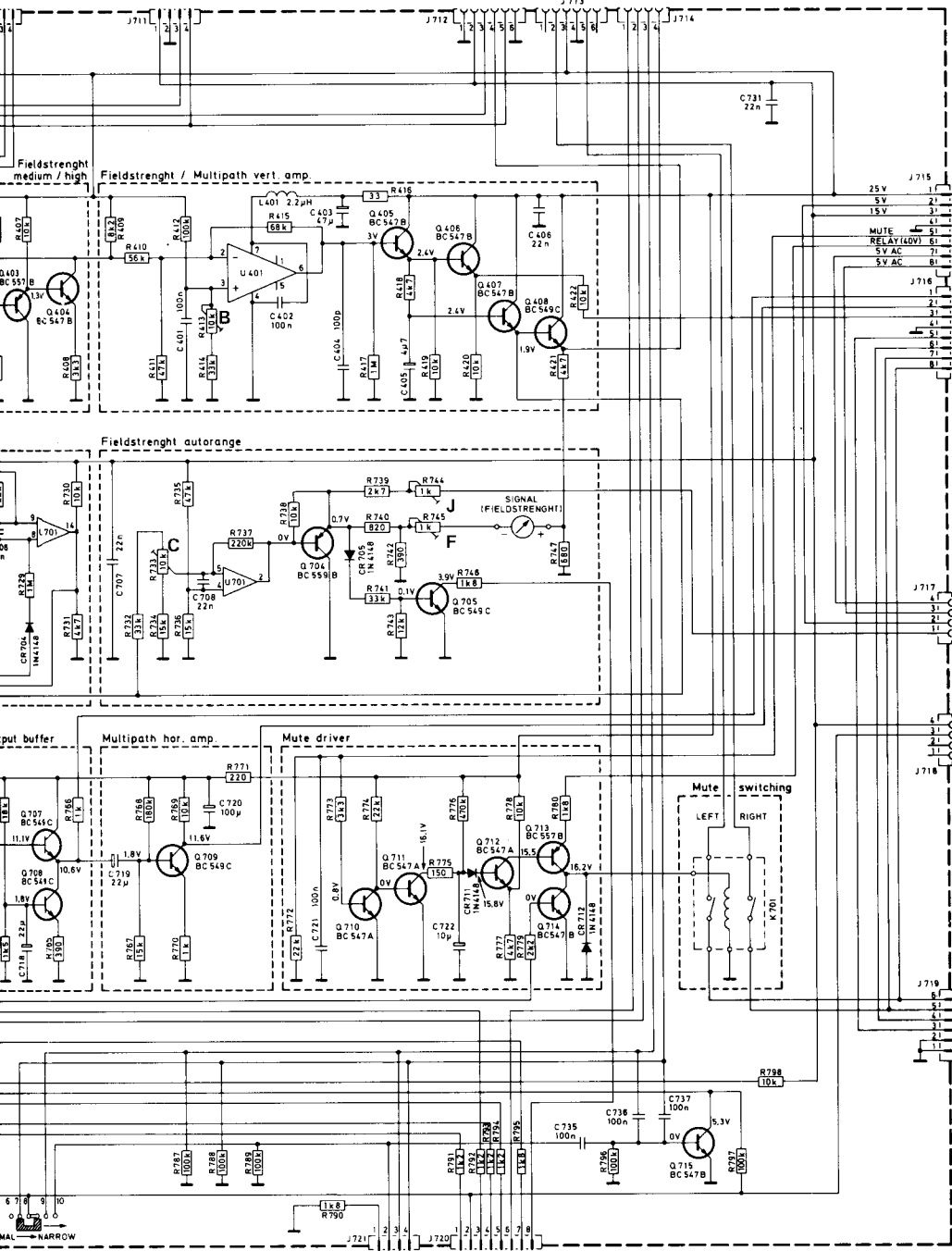
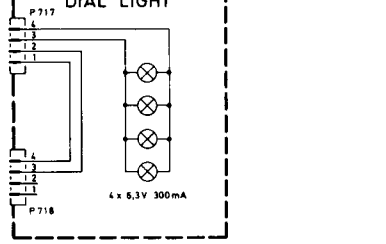
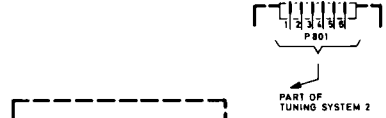
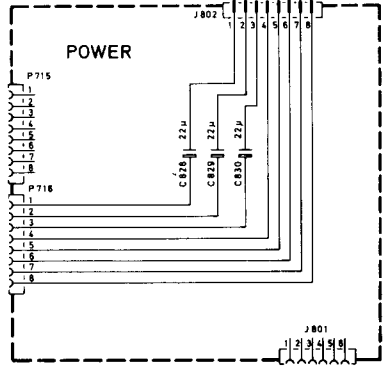
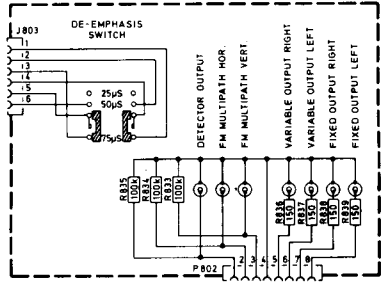
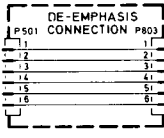
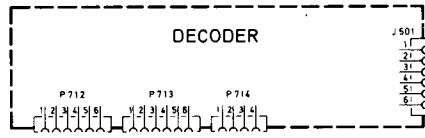
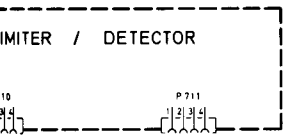

Figure 38 Main circuit diagram



ALL VOLTAGES ARE MEASURED WITH THE TUNER IN POSITION F. NO AERIAL SIGNAL IS APPLIED.

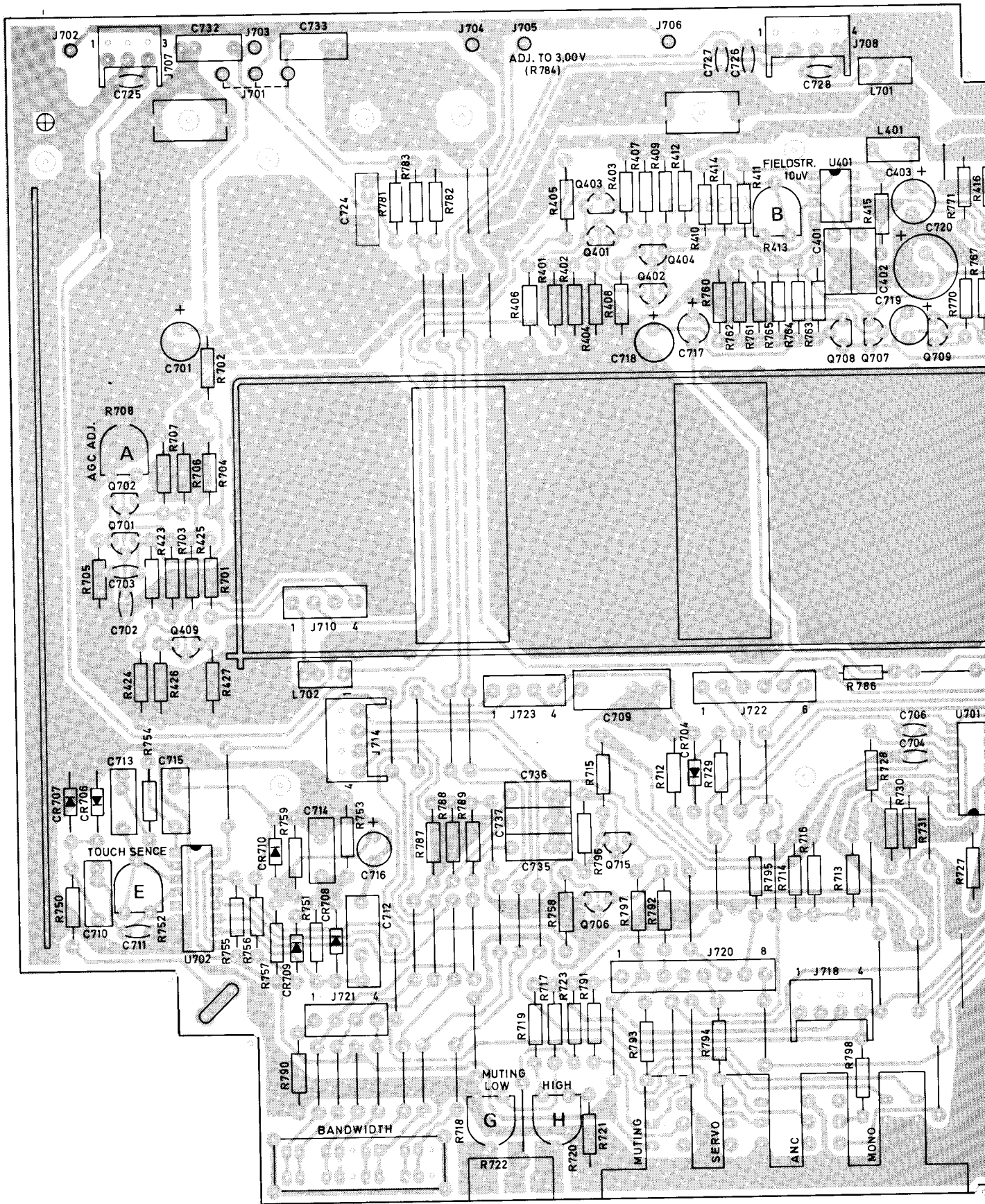
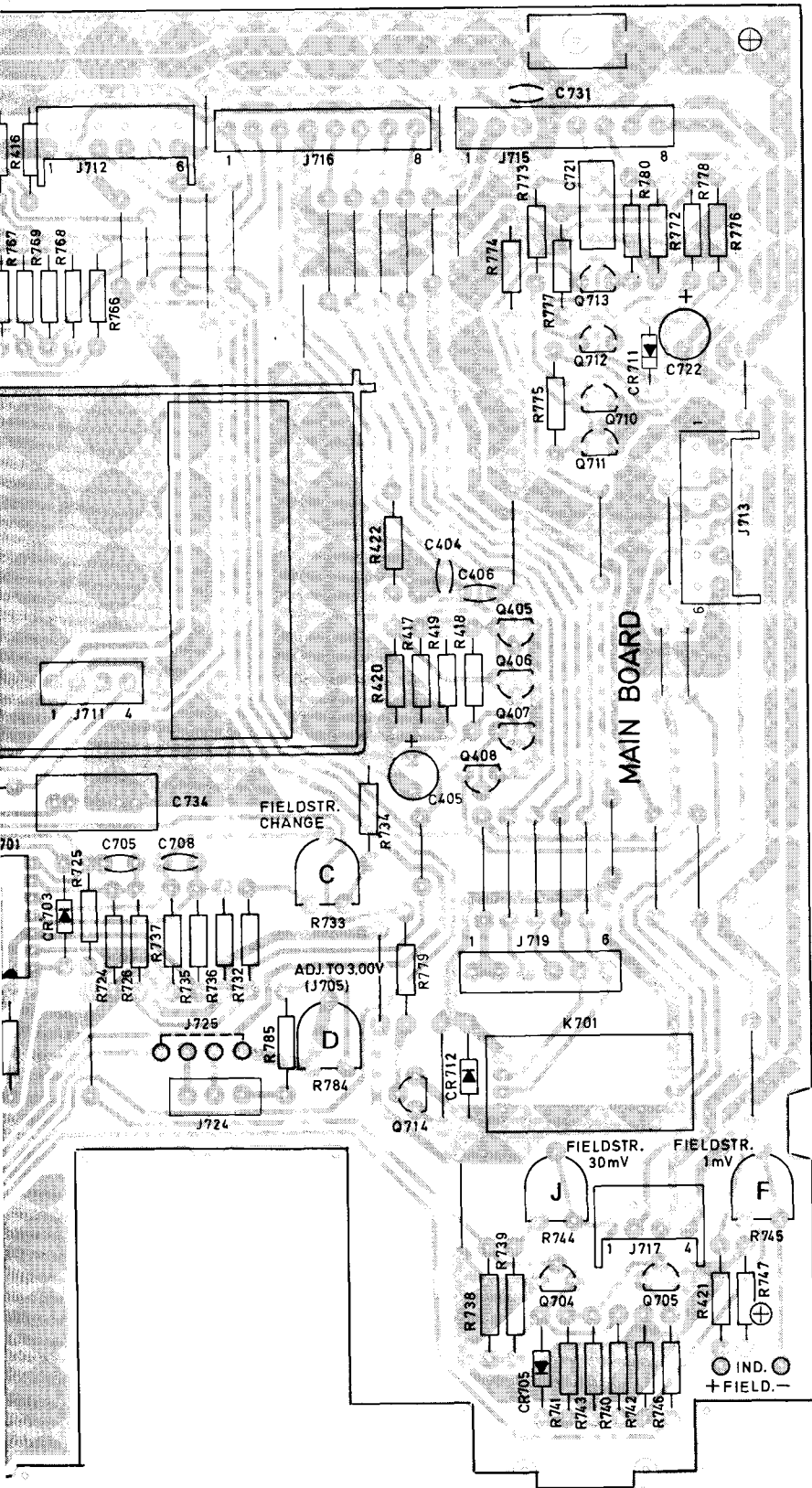

Figure 39 Main board, component side



### Signal meter

- Connect signal generator to the antenna terminal. Signal 98 MHz unmodulated, 1  $\mu$ V/75 ohms.
- Set Bandwidth selector to Normal.
- Adjust R413 (B) for 1  $\mu$ V reading on the Signal meter.
- Increase generator signal to 1 mV/75 ohms.
- Turn R733 (C) fully clockwise until the LED marked Meter Range x 1000 goes off.
- Adjust R745 (F) for 1000  $\mu$ V reading on the Signal meter.
- Turn R733 (C) counterclockwise until the LED marked Meter Range x 1000 just lights and the Signal meter needle falls.
- Adjust R744 (J) for a meter deflection to the figure 1 on the dial.

### Muting Level

- Connect signal generator to the antenna terminal. Signal 98 MHz,  $\pm$  20 kHz modulation, 3  $\mu$ V/75 ohms.
- Connect oscilloscope to the Fixed Output terminal.
- Set the Bandwidth selector to Normal.
- Press the Muting switch.
- Set Muting Level to position 3.
- Adjust R718 (G) to disconnect the muting (signal is let through).
- Set the generator level to 1 mV.
- Set the Muting Level to position 1k.
- Adjust R720 (H) to disconnect the muting (signal is let through).

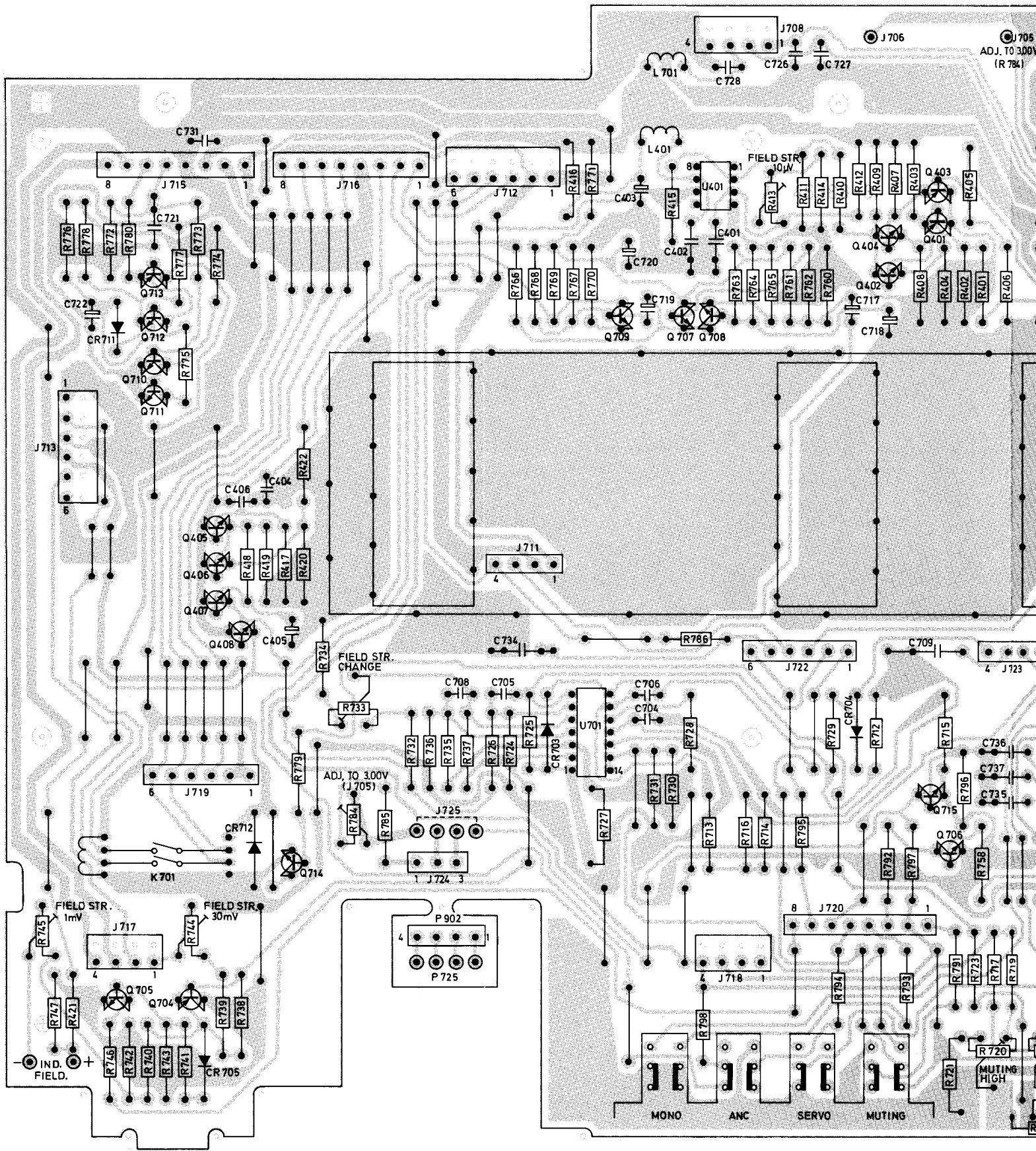
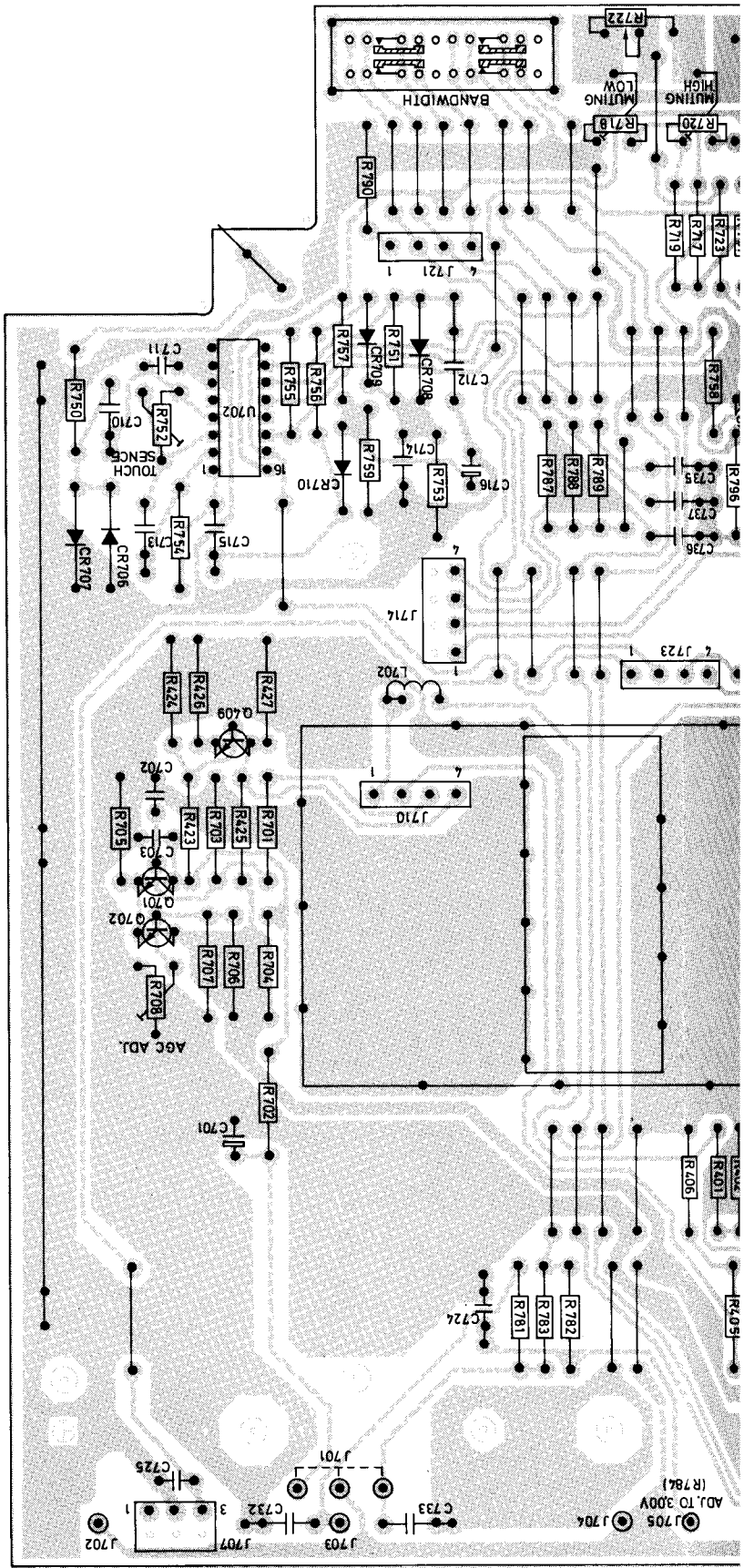

Figure 40 Main board, foil side



## 2.9 Tuning system 1

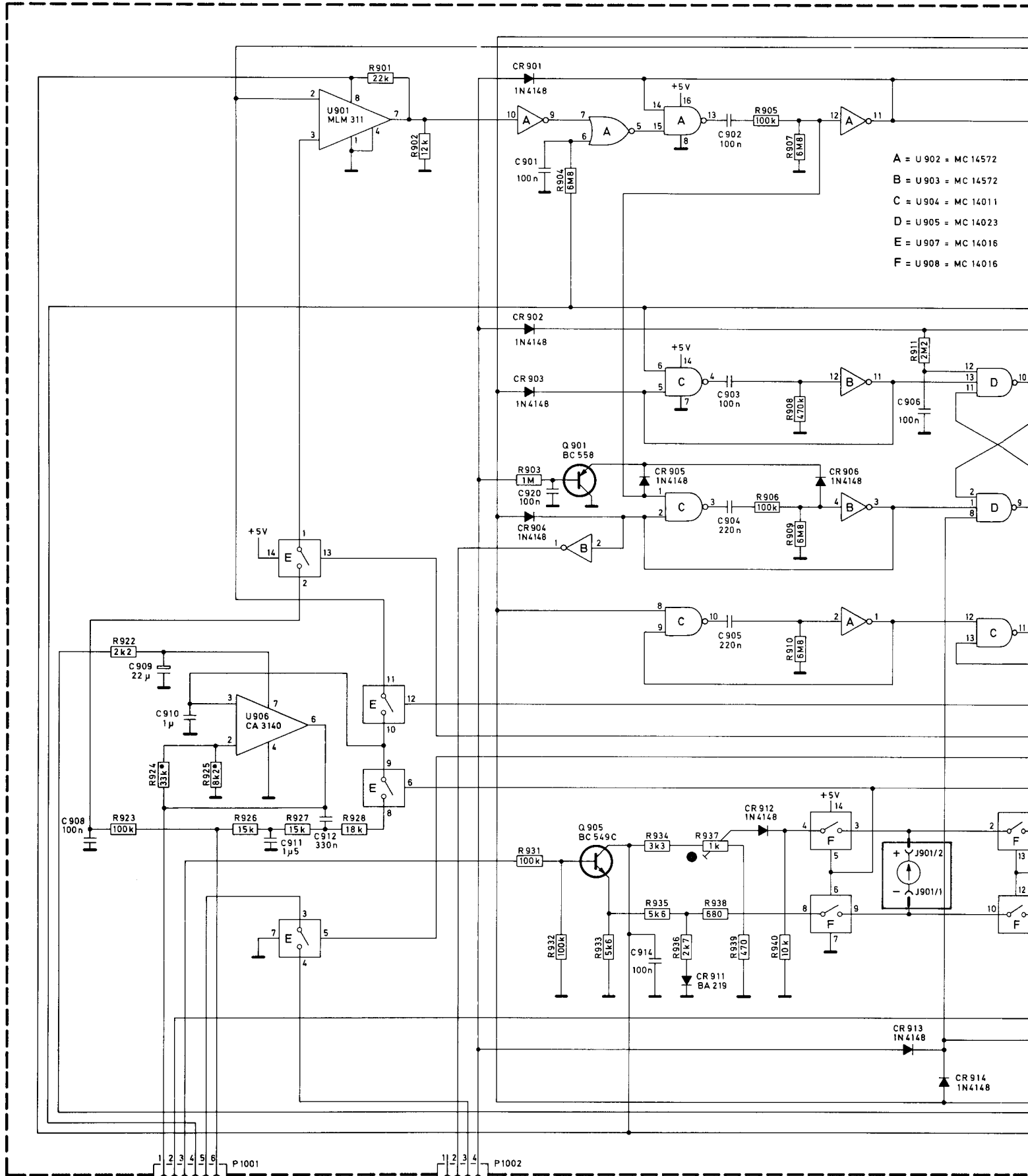
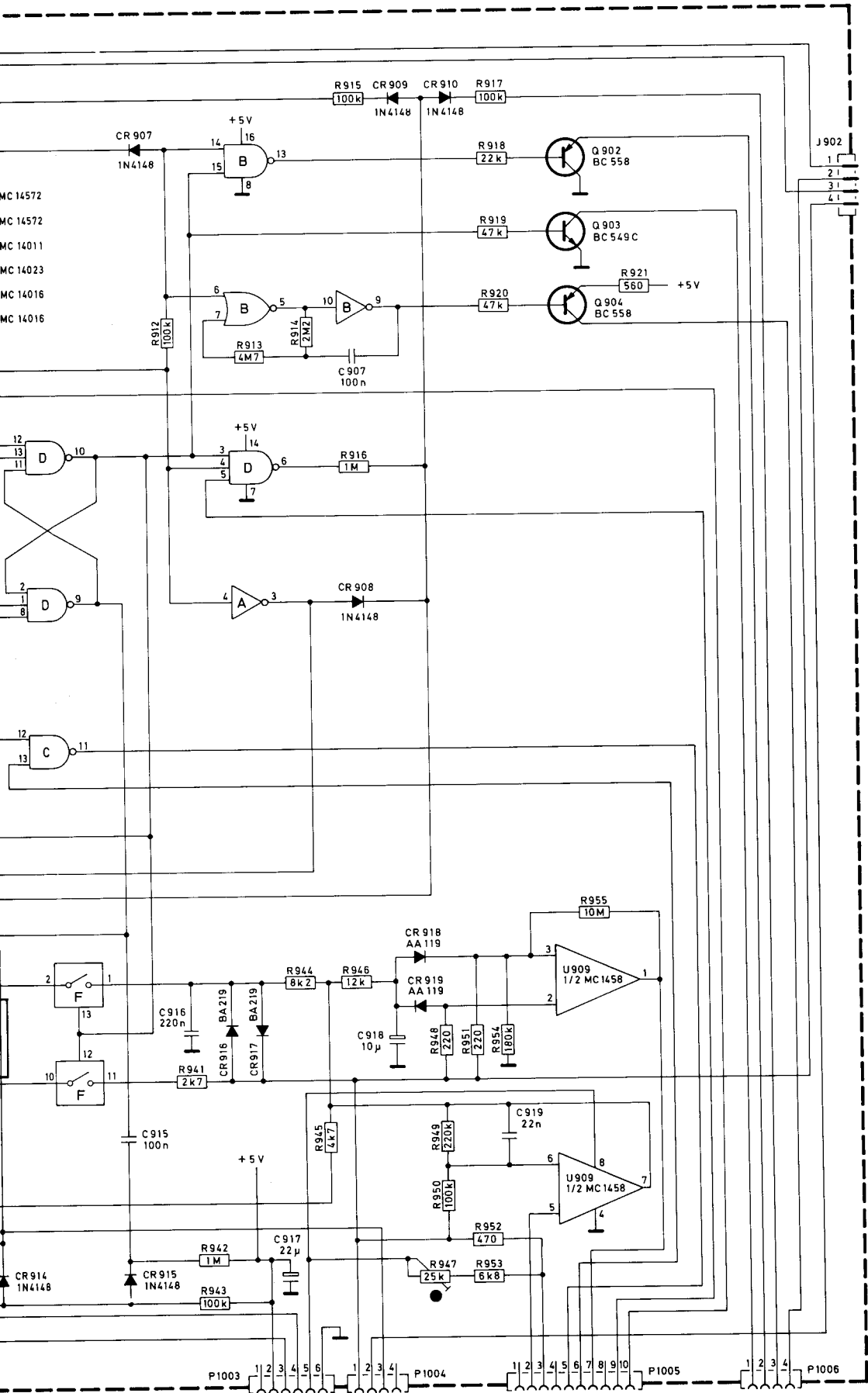

Figure 41 Tuning system 1





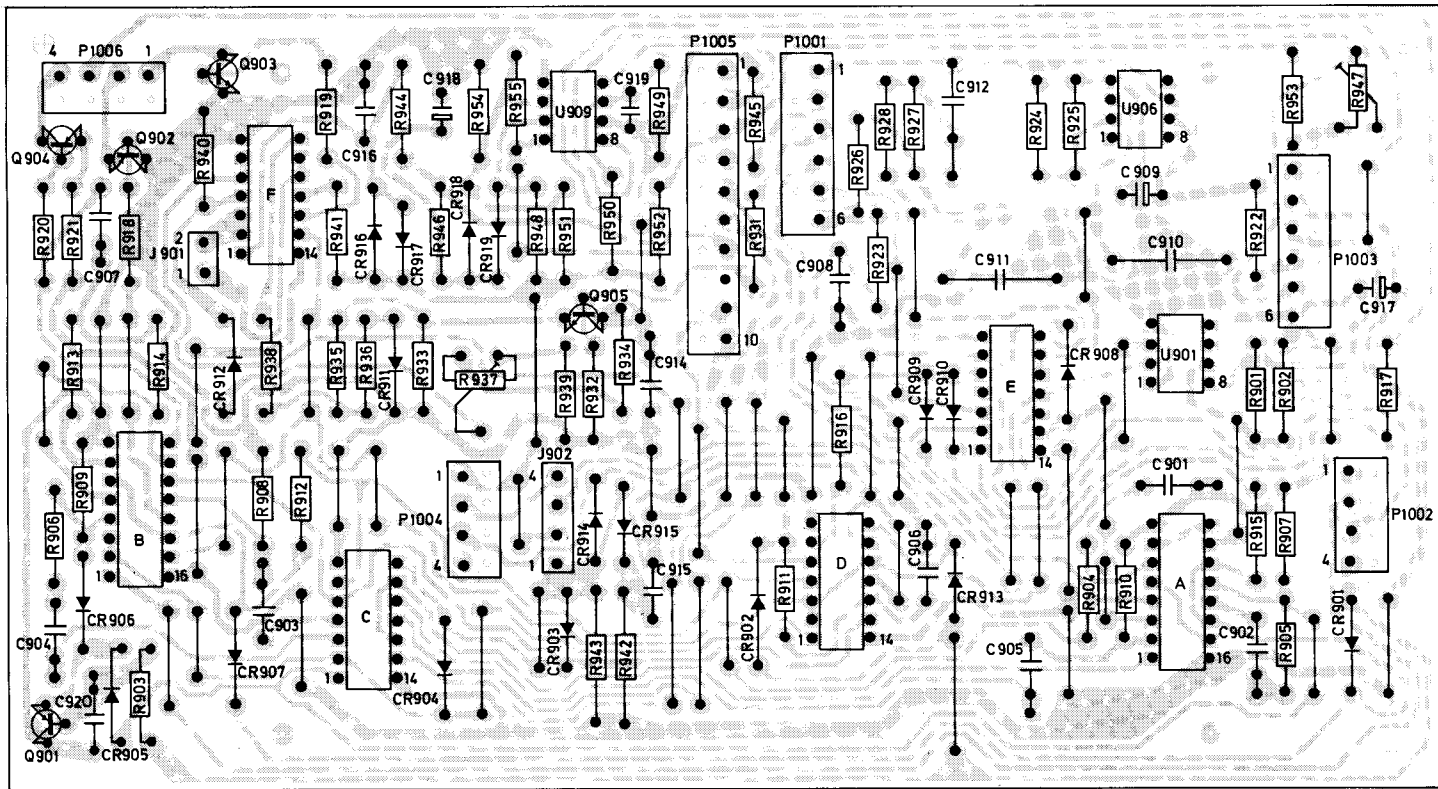

Figure 42 Tuning system 1 board, foil side

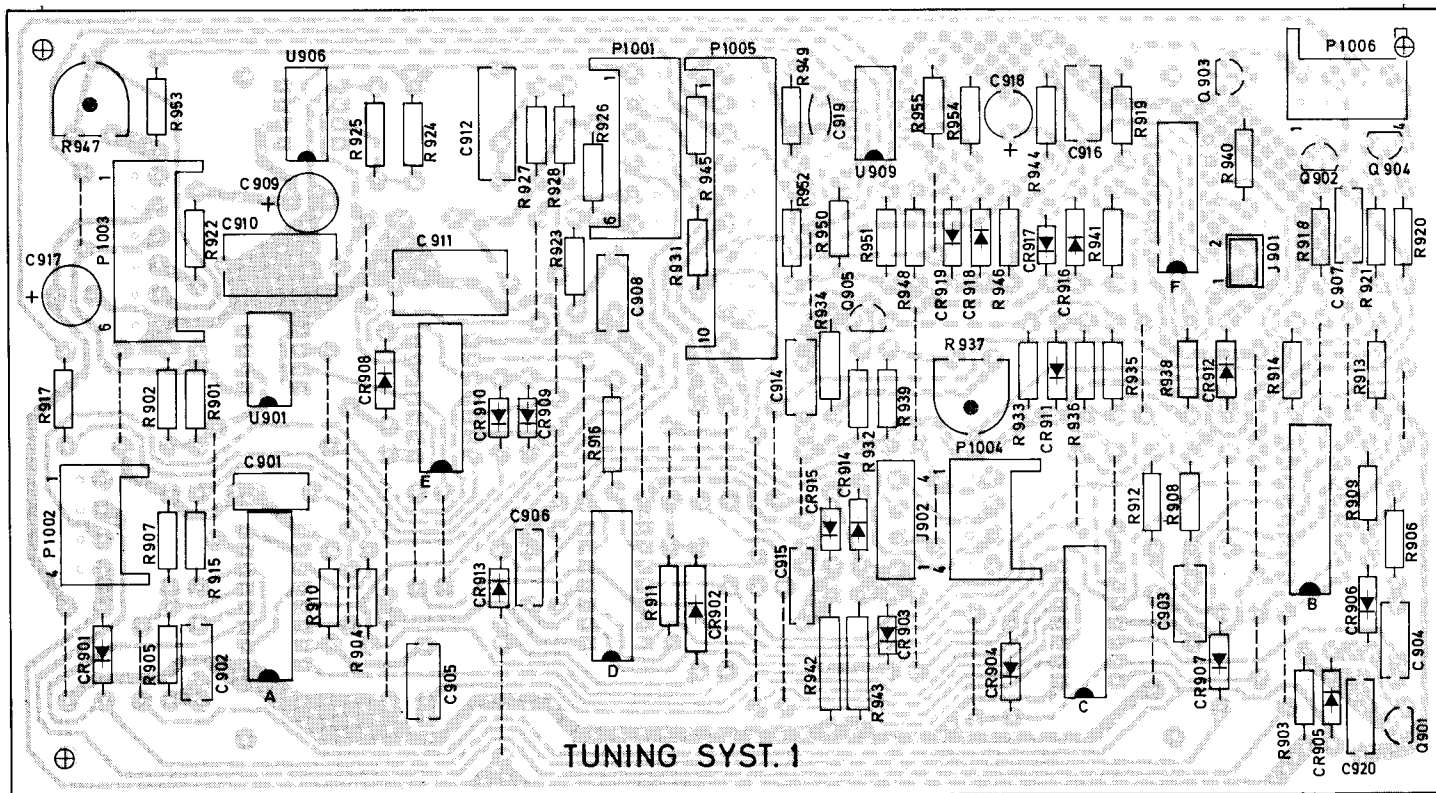

Figure 43 Tuning system 1 board, component side

## The tuning system

- Connect signal generator to the antenna terminal. Signal 98 MHz,  $\pm 75$  kHz modulation, 0.5 mV.
- Connect an oscilloscope (a.c.-mode) to the Multipath Vert. terminal.
- Set Bandwidth selector to position Narrow.
- Place the tuner horizontally to prevent the force of gravity from influencing the meter needle.
- Tune for 98 MHz and symmetrical sinewave on the oscilloscope.
- Adjust R947 to obtain mid-scale position of the Tuning meter needle.
- Check that electrical mid-position corresponds with physical mid-position by disconnecting plug J901. This should not influence the position of the needle. If necessary, adjust R947.
- Press the Servo button.
- Adjust R1002 (Tuning system 2, figure 44) for symmetrical sinewave on the oscilloscope.

## Preset dial

- Set the tuner to 88 MHz on the main dial.
- Press Program Preset 1.
- Press Store Program.
- Adjust R937 for pointer deflection to the 88 MHz mark on the Tuning/Frequency meter, lower dial.

## Touch sense

- Turn R752 (figure 44) counterclockwise to increase the touch sensitivity on the Tuning knob.
- On some tuners the pot.meter R752 is replaced by a fixed resistor. Increased resistance will give increased sensitivity.

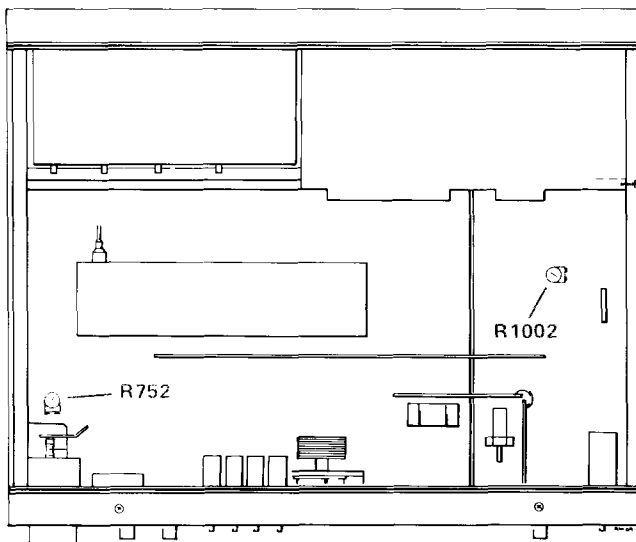

Figure 44 Test points

- Press Program Preset 1.
- Press Store Program.
- When the programming is finished control the frequency deviation by adjusting the generator frequency for symmetrical sinewave on the oscilloscope. Tolerance: 20 kHz deviation.
- If the deviation exceeds 20 kHz, this can be due to inaccurate adjustment of the Tuning indicator, the AFC or the d.c. reference voltage in the detector.

## 2.10 Tuning system 2

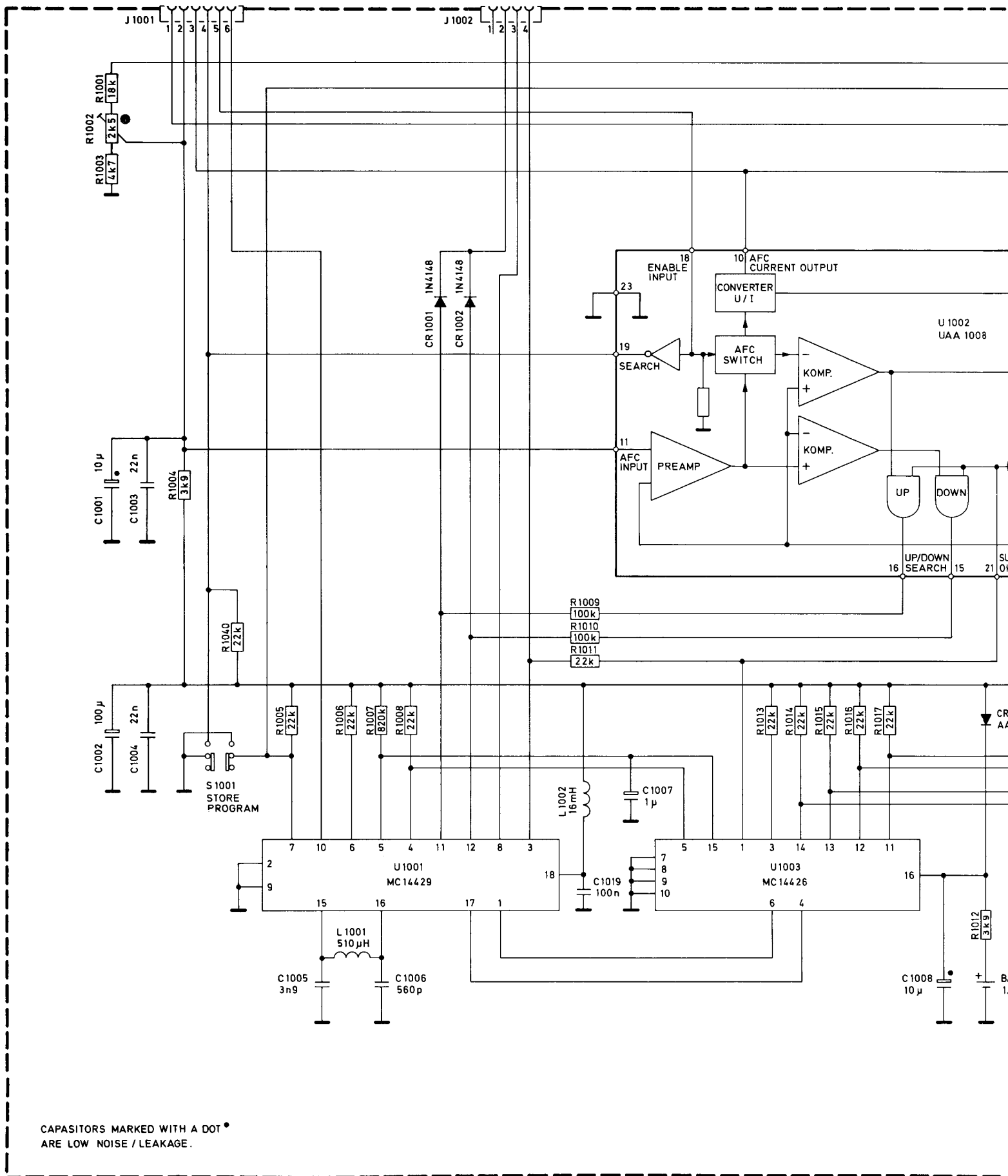
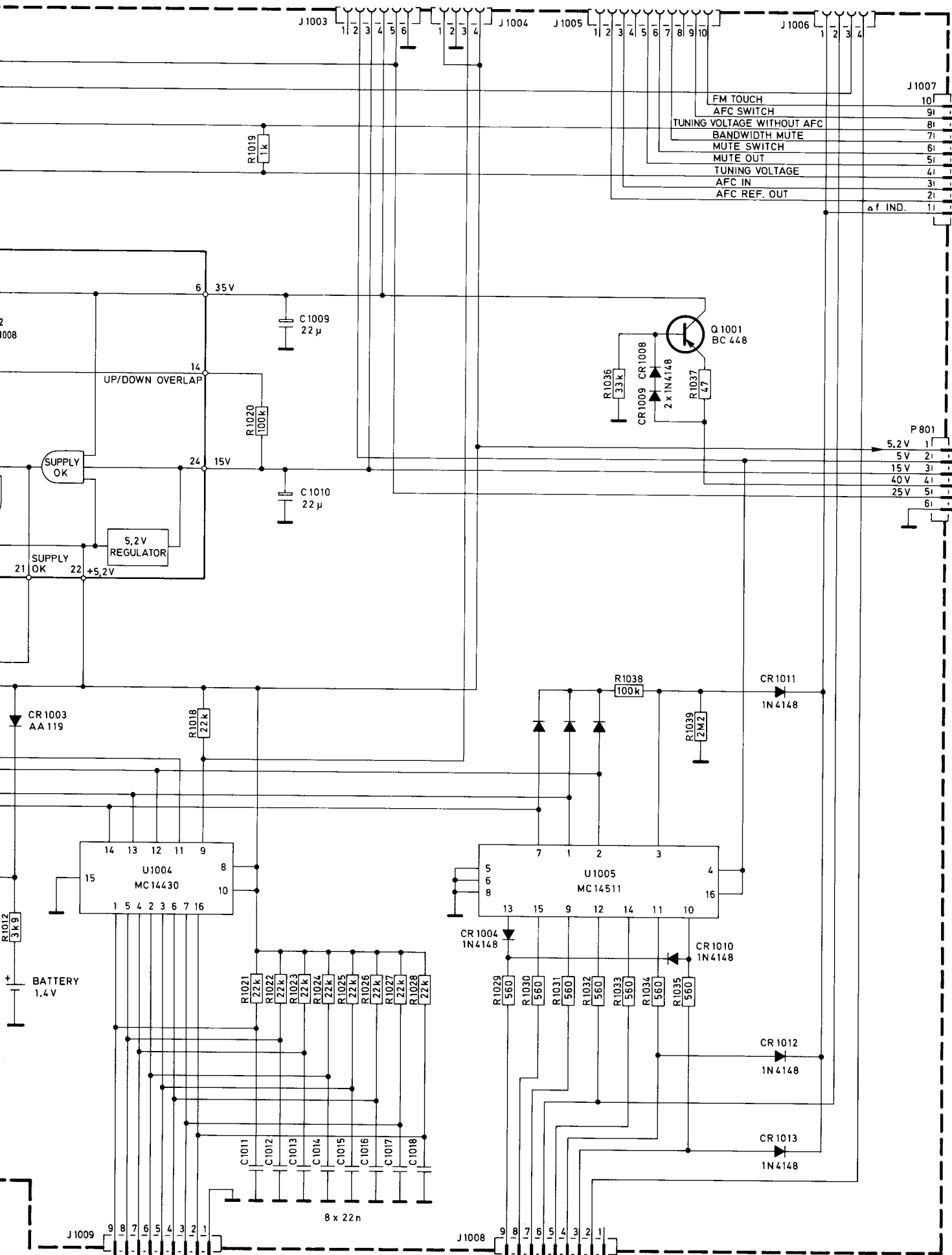

Figure 45 Tuning system 2



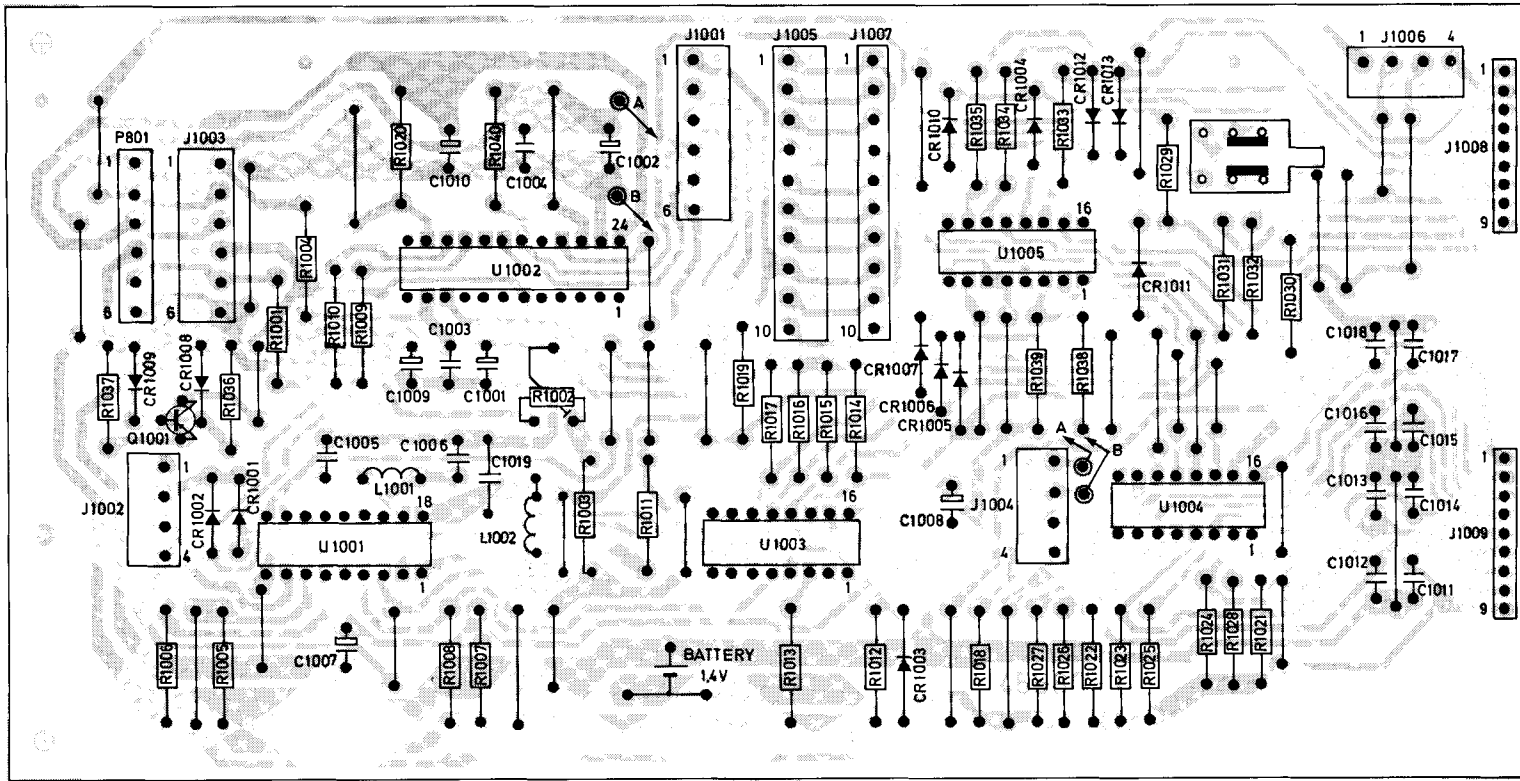

Figure 46 Tuning system 2 board, foil side

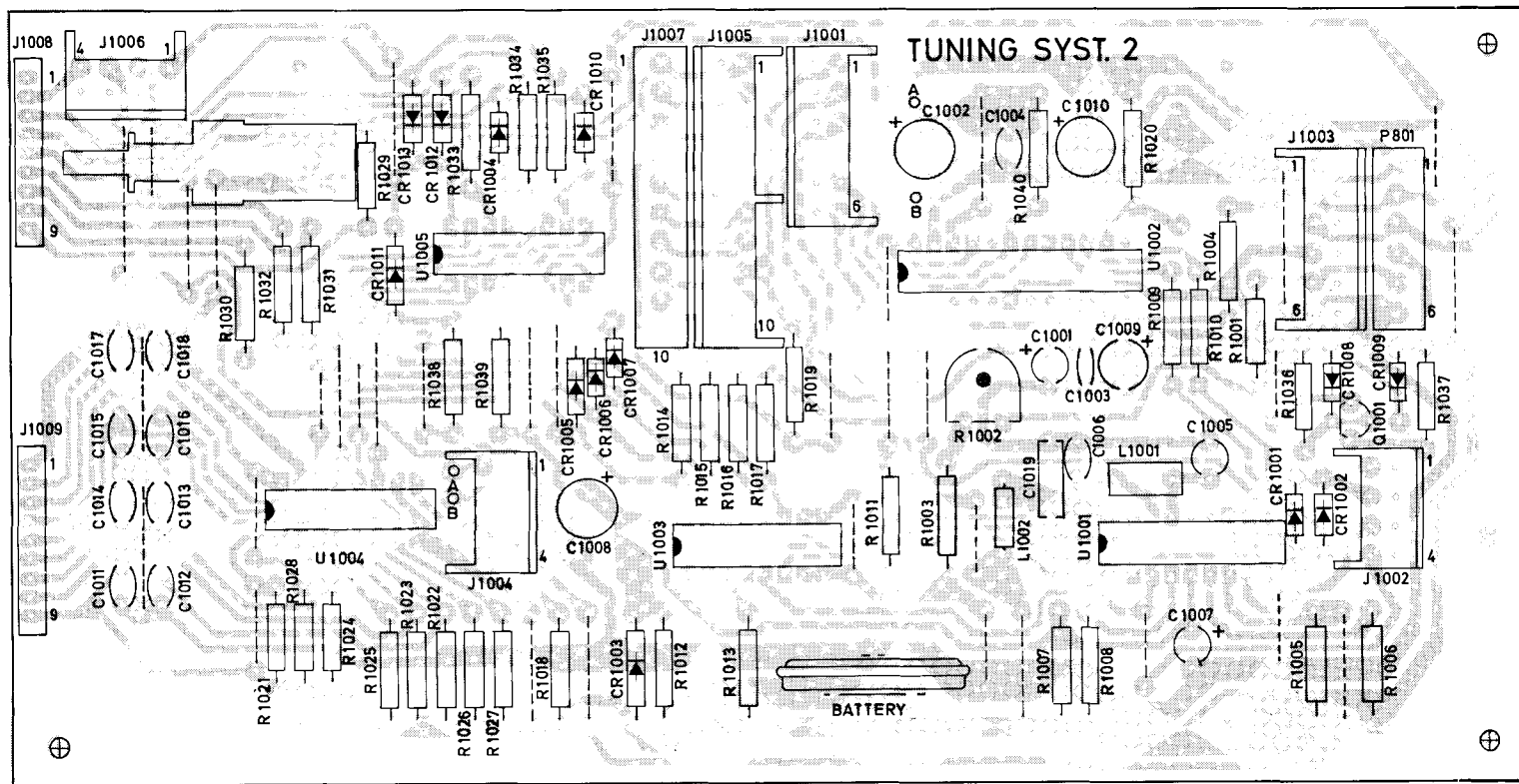

Figure 47 Tuning system 2 board, component side

# 2.11 Stereo decoder

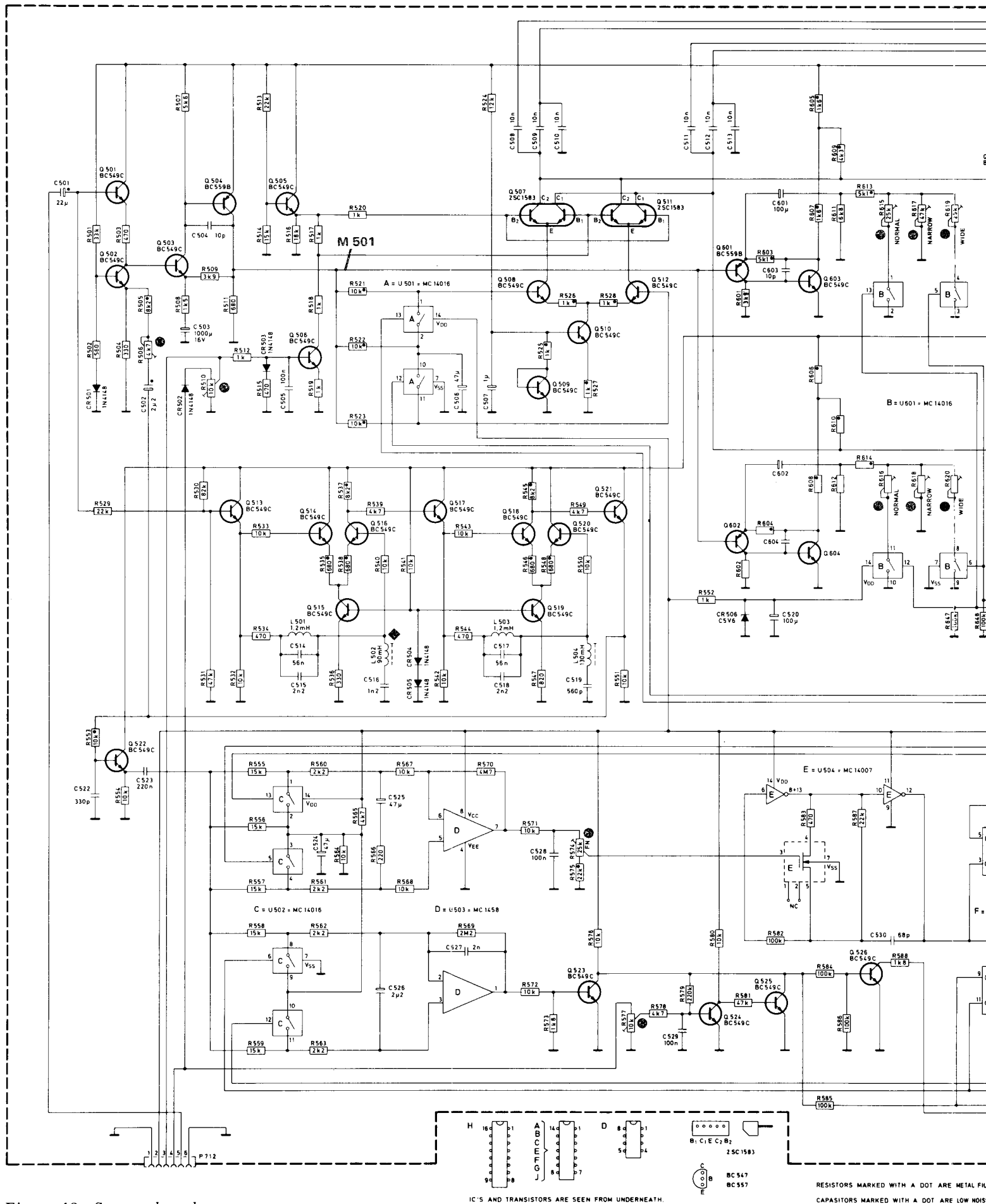
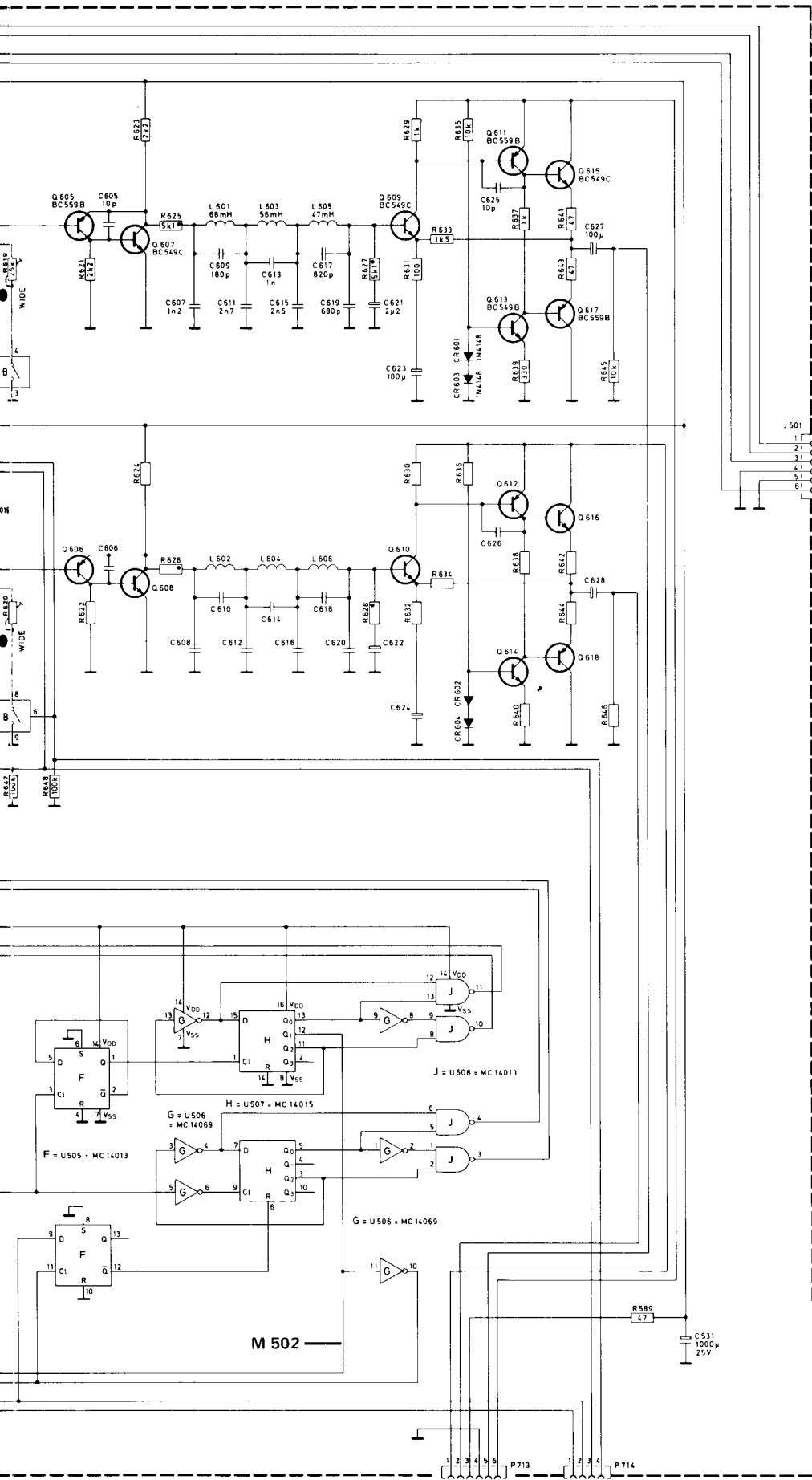

Figure 48 Stereo decoder

IC'S AND TRANSISTORS ARE SEEN FROM UNDERNEATH.

RESISTORS MARKED WITH A DOT ARE METAL FILM  
CAPACITORS MARKED WITH A DOT ARE LOW NOISE



### 19 kHz oscillator

- Connect signal generator to the antenna terminal. Signal 98 MHz,  $\pm 75$  kHz modulation mono, 0.5 mV/75 ohms.
- Connect an oscilloscope (a.c.-mode) to the FM Multipath Vert. terminal.
- Set Bandwidth selector to Narrow.
- Use the Tuning knob to tune in to 98 MHz on the main dial, and fine-tune for symmetrical sinewave on the oscilloscope.

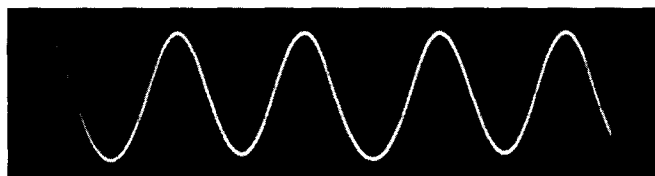

Figure 49 Symmetrical sinewave, mono

- Switch off the modulation.
- Connect frequency counter to M502. Arrange the leads to the counter the shortest possible way out of the tuner.
- Adjust R574 for 19.00 kHz on the frequency counter.

### Mono/Stereo switching

- Set the signal generator in Stereo position with only 10% pilot tone, 7  $\mu$ V.
- Set the Bandwidth selector to Normal.
- Adjust R577 until the MPX indicator lights up.
- Set the Bandwidth selector to Narrow.
- Connect a selective voltmeter (19 kHz bypass-filter) or an oscilloscope with high sensitivity (1 mV) to M501, and use M601 for ground.
- Increase the generator signal level to 500  $\mu$ V.
- Adjust L502 and R506 alternately several times to obtain minimum 19 kHz.

### Stereo separation

- Connect signal generator to antenna terminal. Signal 98 MHz,  $\pm 75$  kHz modulation, stereo L, 1 kHz, 0.5 mV.
- Connect oscilloscope to the FM-Multipath Vert. terminal.

- Set Bandwidth selector to Narrow.
- Tune for 98 MHz and symmetrical sinewave on the oscilloscope.

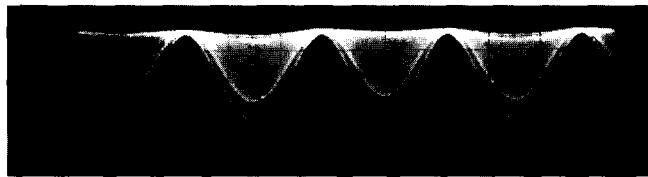

Figure 50 Symmetrical sinewave, stereo

- Connect AC-voltmeter to Fixed Output L and read the output level, approx. 2.2 V.
- Connect a selective voltmeter (1 kHz bypass-filter) to Fixed Output R.
- Press Servo (AFC).

### Adjustments

Bandwidth	Adjust	for	Separation
Narrow	R618	minimum	55 dB
Normal	R616	voltage at	60 dB
Wide	R620	Fixed Output R	70 dB

- Switch generator to Stereo R.
- Connect the selective voltmeter to Fixed Output L.

Bandwidth	Adjust	for	Separation
Narrow	R617	minimum	55 dB
Normal	R615	voltage at	60 dB
Wide	R619	Fixed Output L	70 dB

### ANC

- Connect signal generator to antenna terminal. Signal 98 MHz,  $\pm 75$  kHz modulation, stereo R, 1 kHz, 0.5 mV/75 ohms.
- Connect a selective voltmeter (1 kHz bypass-filter) to Fixed Output R.
- Bandwidth selector to Normal.
- Press ANC.
- Adjust R510 for 30 dB channel separation.



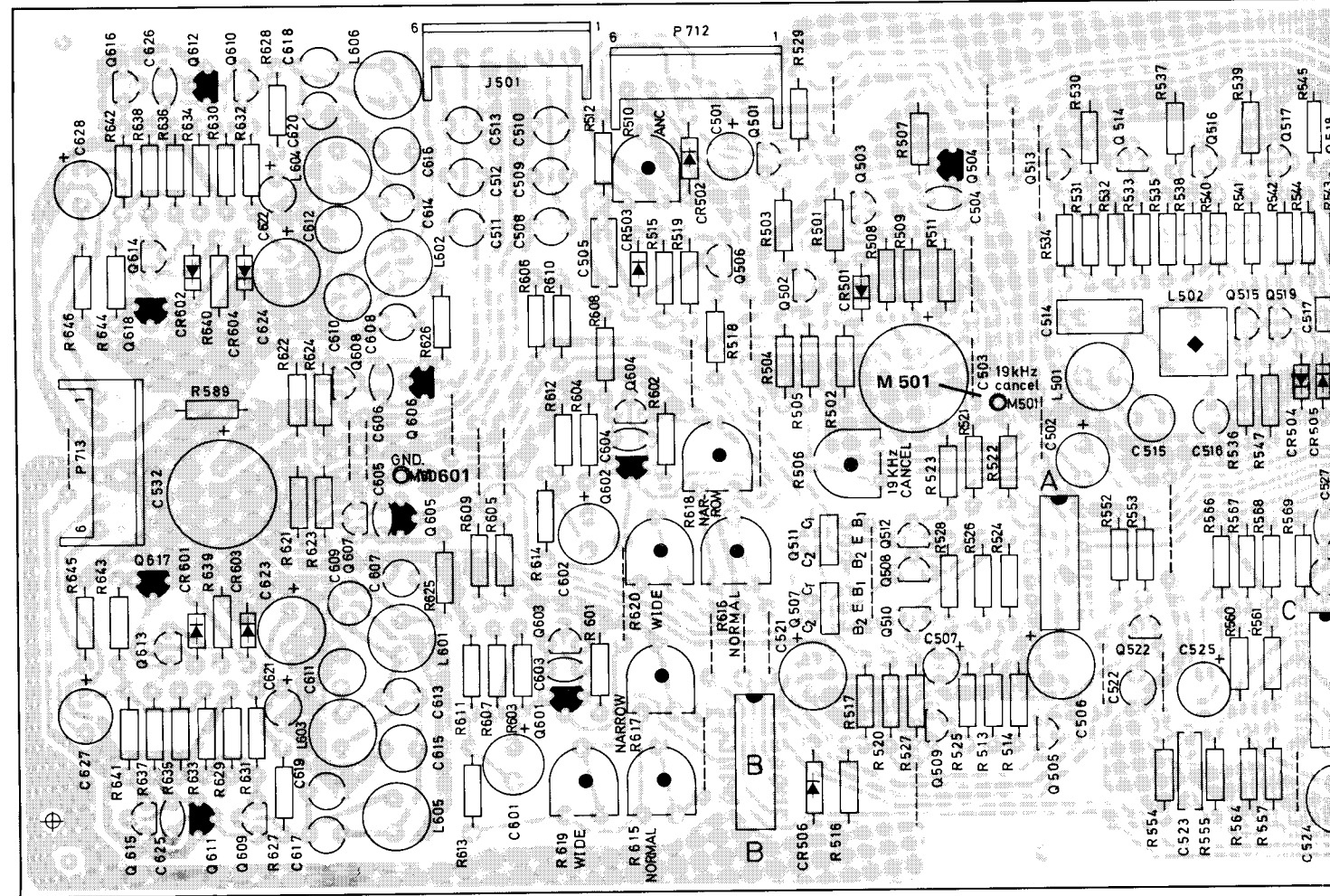
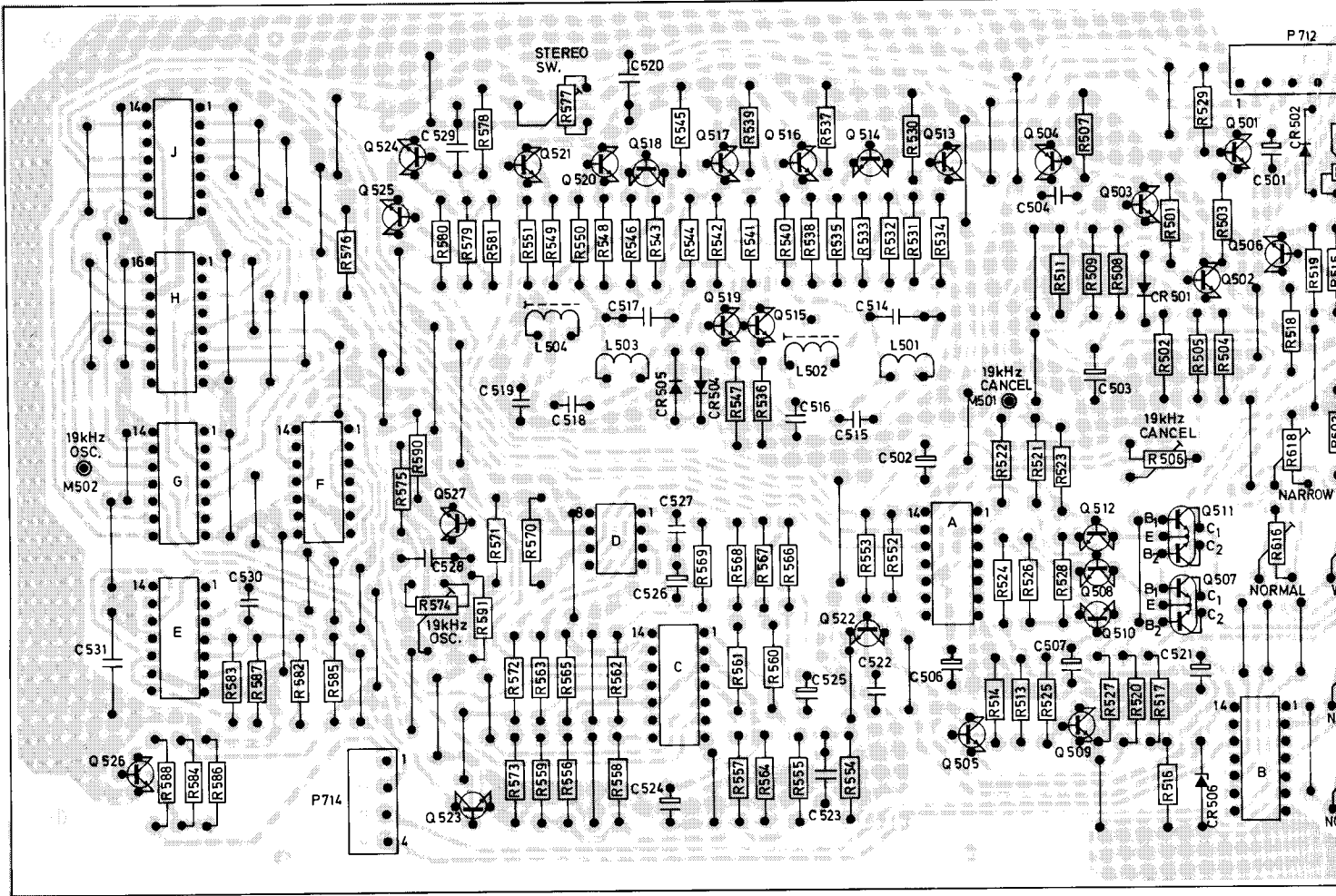

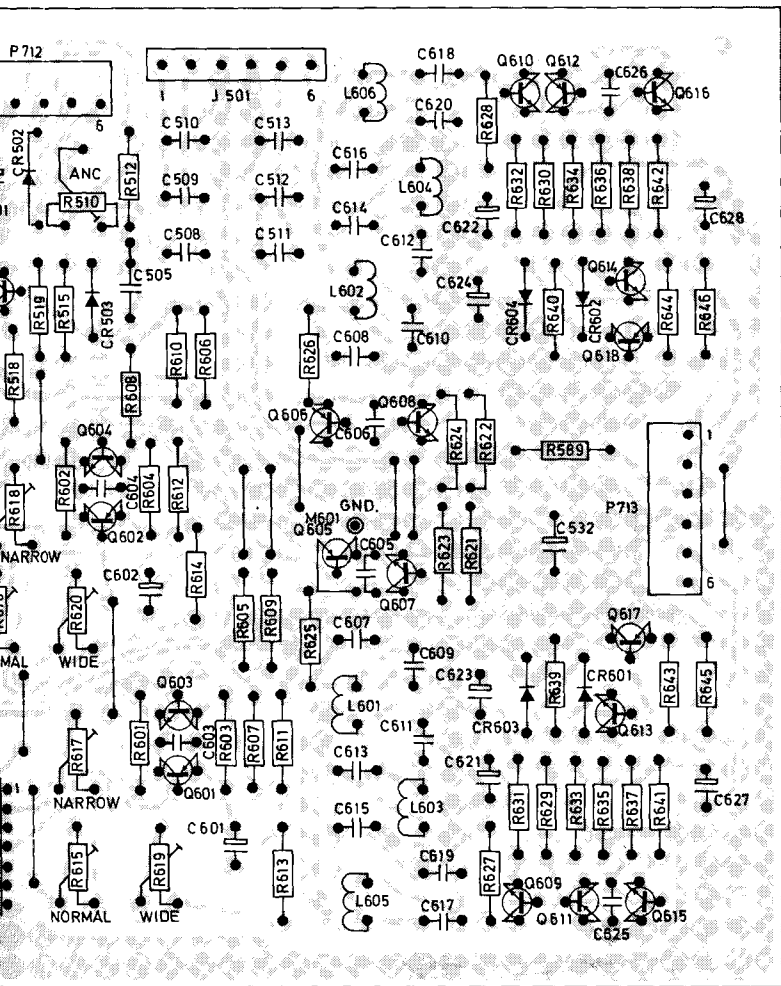

Figure 51 Stereo decoder board, foil side

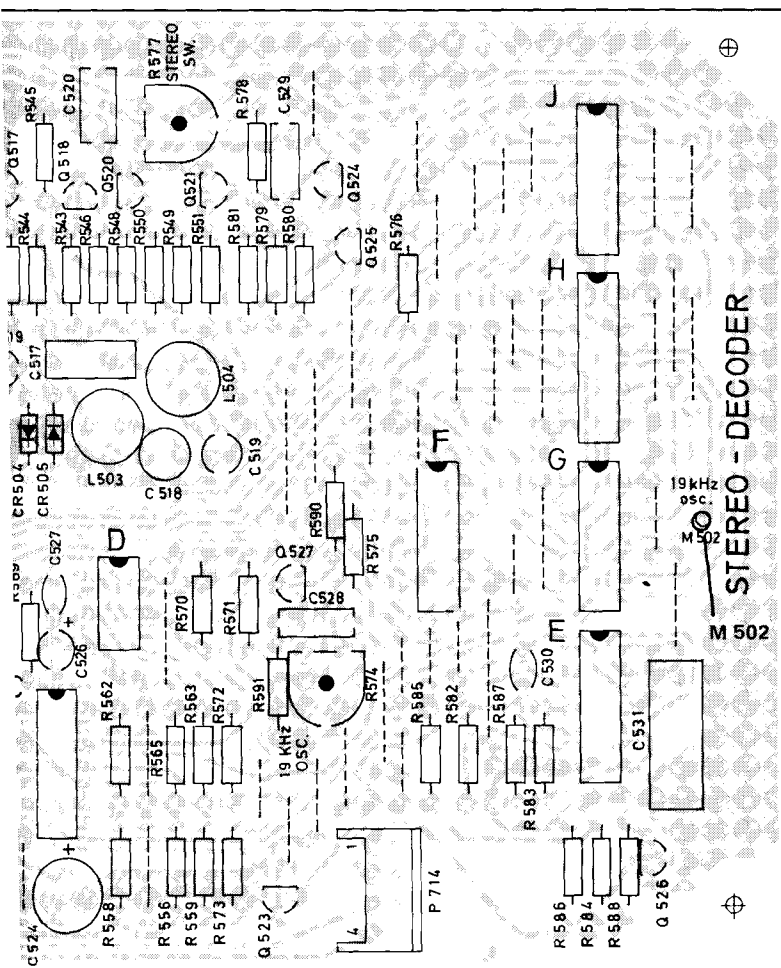
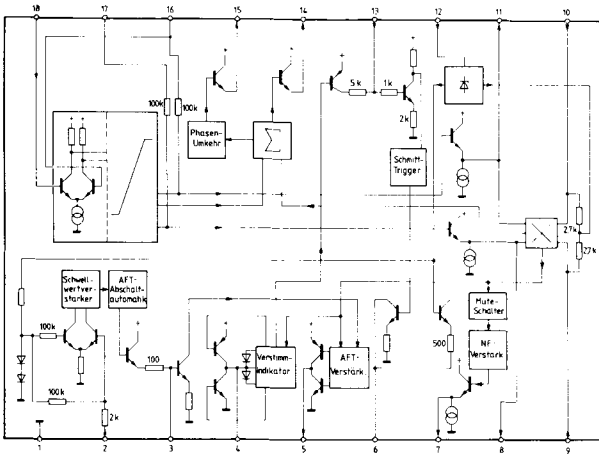

Figure 52 Stereo decoder board, component side

## 2.12 Integrated Circuits



**U301**  
**TDA1047**

**U401**  
**MC1741CP**

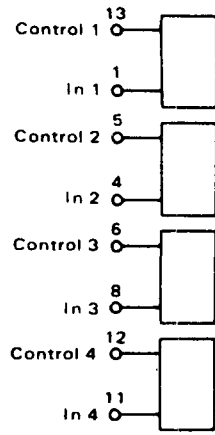
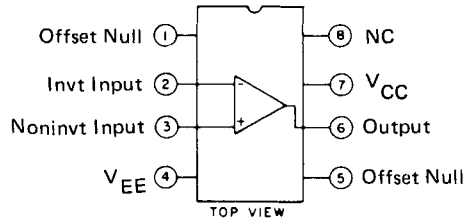

**U501/502/601/907/908**  
**MC14066CP**

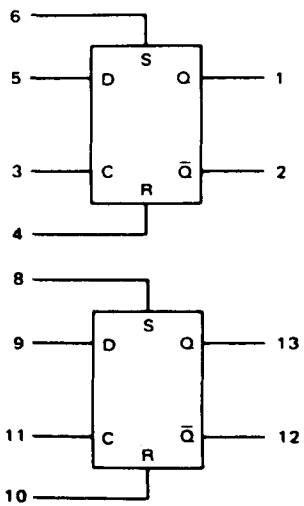

$V_{DD}$  = Pin 14  
 $V_{SS}$  = Pin 7

**U505**  
**MC14013**

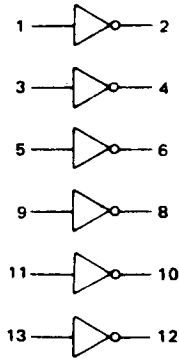

$V_{DD}$  = Pin 14  
 $V_{SS}$  = Pin 7

**U506**  
**MC14069**

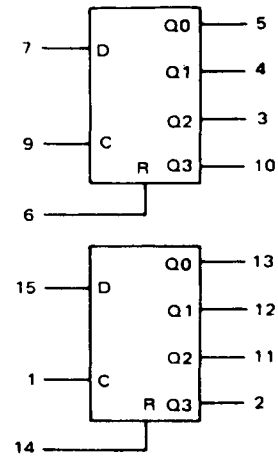

$V_{DD}$  = Pin 16  
 $V_{SS}$  = Pin 8

**U507**  
**MC14015**

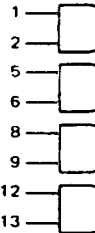

$V_{DD}$  = Pin 1  
 $V_{SS}$  = Pin

**U508/904**  
**MC14011**

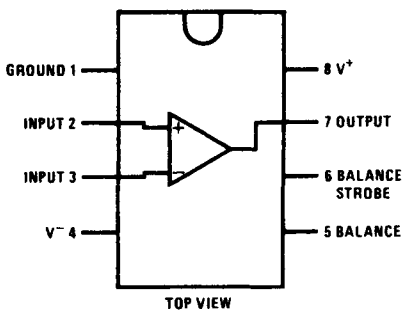

**U901**  
**MLM311**

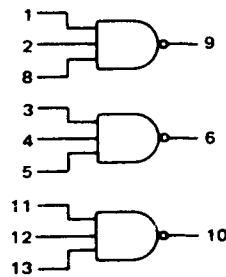

$V_{DD}$  = Pin  
 $V_{SS}$  = Pin 7

**U905**  
**MC14023**

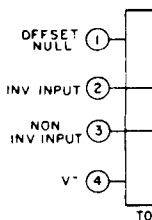

**U906**  
**CA3140**

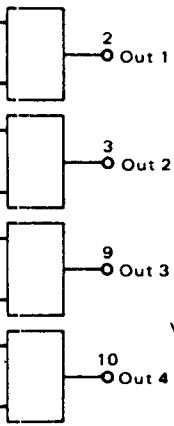

VDD = Pin 14  
VSS = Pin 7

U507/908

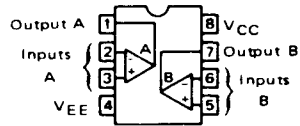

U503/909  
MC1458

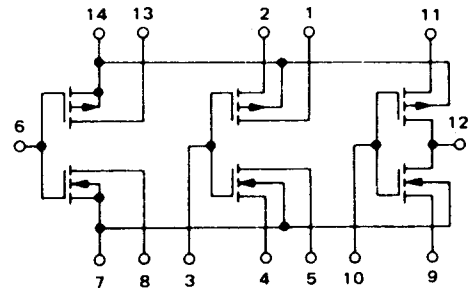

U504  
MC14007

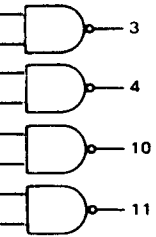

VDD = Pin 14  
VSS = Pin 7

U508/904  
MC14011

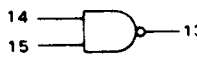
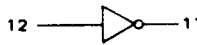
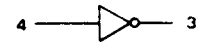
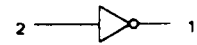

VDD = Pin 16  
VSS = Pin 8

U701/902/903  
MC14572

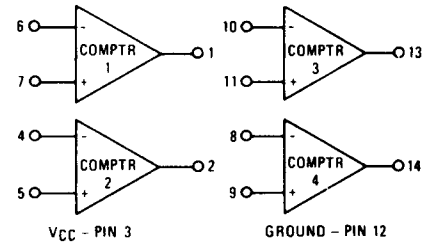

U702  
MC3302

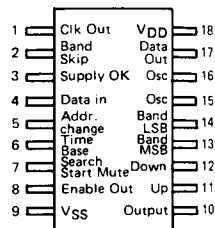
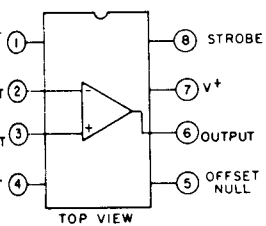

U1001  
MC14429

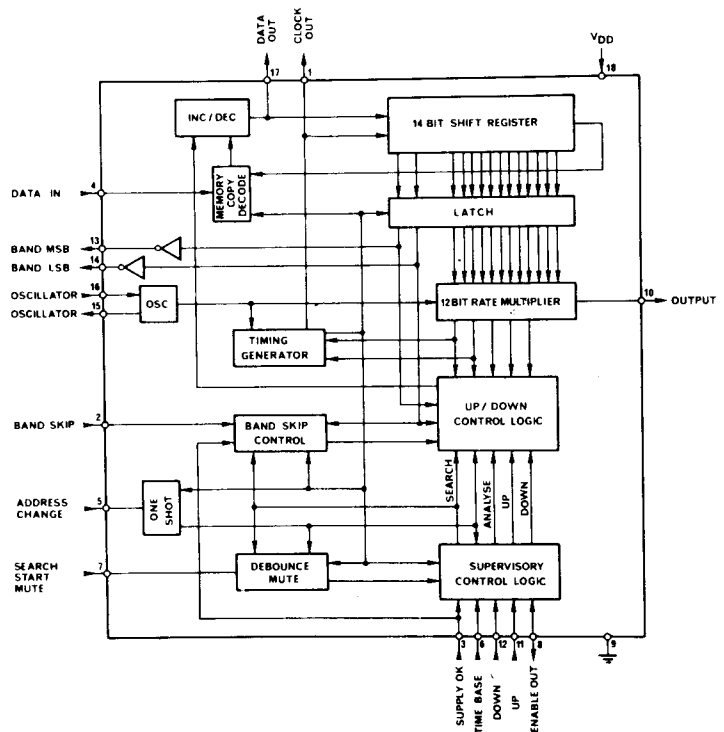

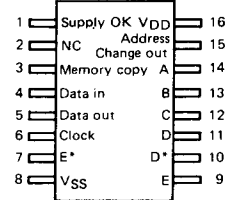
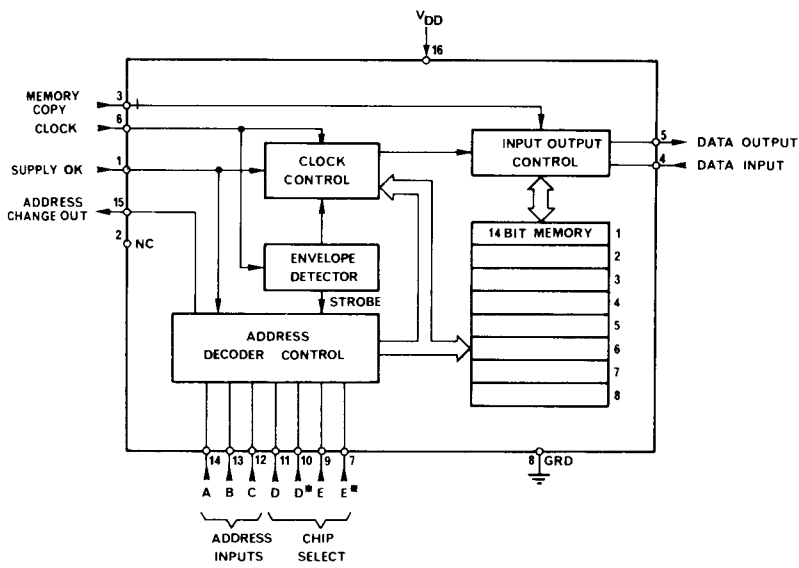

U1003  
MC14426

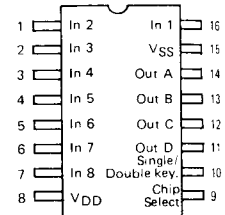
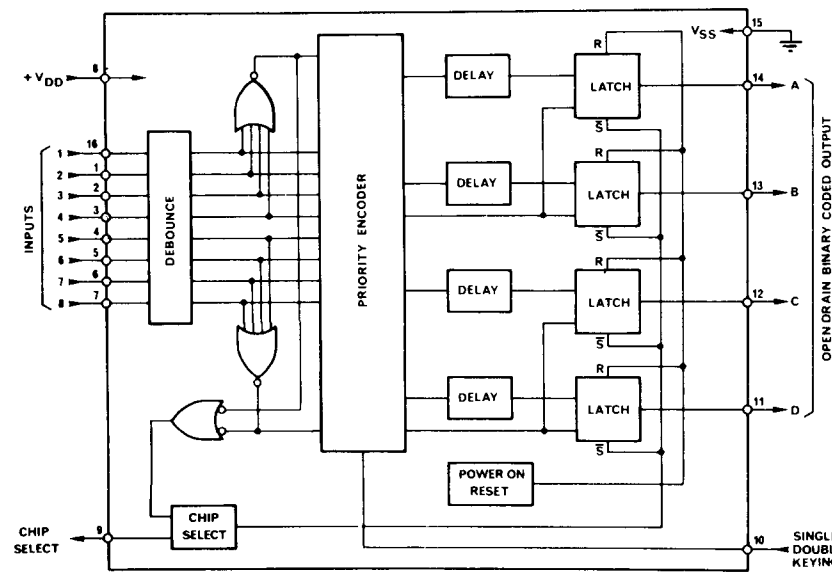

U1004  
MC14430

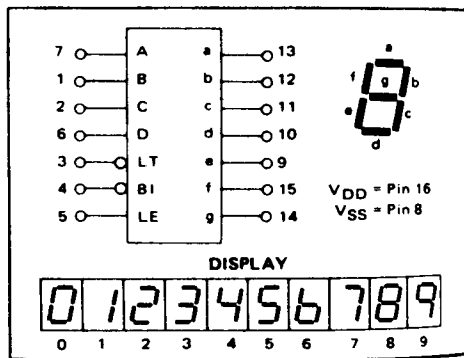

U1005  
MC14511B

## 2.13 Other PC boards

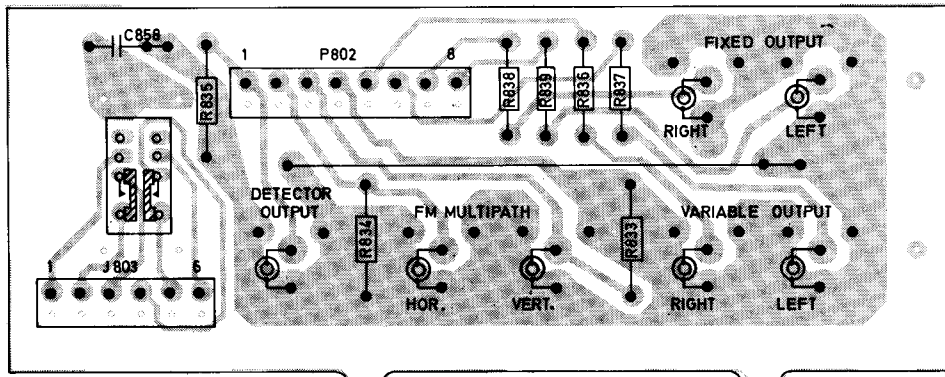

Figure 53 Output connector board, foil side

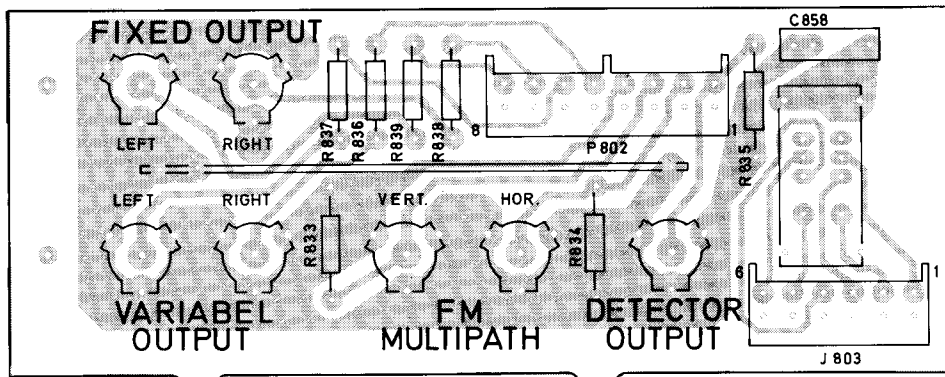

Figure 54 Output connector board, component side

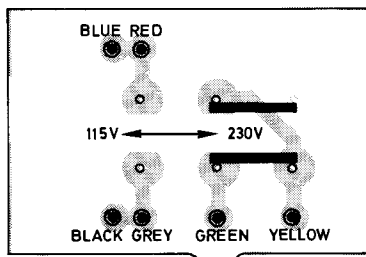

Figure 55 Voltage selector board, foil side.

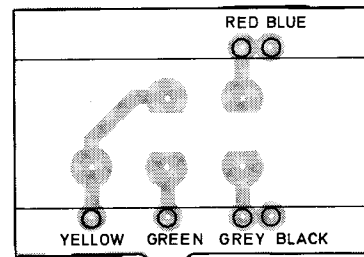

Figure 56 Voltage selector board, component side

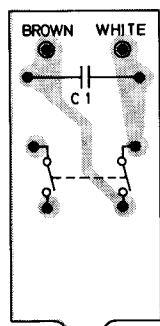

Figure 57 Power switch board, foil side

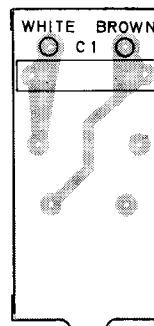

Figure 58 Power switch board, component side

## 4.0 Technical specifications

<b>Power requirements:</b>	230/115 V $\pm$ 10%, 50/60 Hz
<b>Power consumption:</b>	34 W
<b>Outlets:</b>	Fixed Output, Variable Output, FM-Multipath and Detector Output
<b>Dimensions:</b>	Width: 17 1/8" (43.5 cm)
	Depth: 13 3/4" (35.0 cm)
	Height: 3 1/4" ( 8.3 cm)
	Weight: 15.3 lbs (7 kg)

### Technical Data according to IHF-T-200, 1975 IEEE Std. 185, 1975

<b>Tuning range:</b>	87.5 – 108 MHz		
<b>Antenna impedance:</b>	75 ohms unbalanced		
<b>Usable sensitivity (measured with notch filter):</b>	Wide	Normal	Narrow
<b>50 dB quieting sensitivity:</b>	Mono 0.65 $\mu$ V ( 7.5 dBf)	0.6 $\mu$ V ( 6.8 dBf)	0.7 $\mu$ V ( 8.2 dBf)
	Mono 1.0 $\mu$ V (11.25 dBf)	0.9 $\mu$ V (10.3 dBf)	0.8 $\mu$ V ( 9.3 dBf)
	Stereo 11.0 $\mu$ V (32.1 dBf)	11.0 $\mu$ V (32.1 dBf)	11.0 $\mu$ V (32.1 dBf)
	Stereo 5.0 $\mu$ V (25.2 dBf)	5.0 $\mu$ V (25.2 dBf)	5.0 $\mu$ V (25.2 dBf)
With noise filter ANC 10 dB channel separation:			
<b>Signal to noise ratio at 65 dBf, 0.5 mV:</b>	Mono 95 dB	95 dB	95 dB
	Stereo 82 dB	82 dB	82 dB
	Stereo 92 dB	92 dB	92 dB
<b>Signal to noise ratio at 85 dBf, 5 mV:</b>	Mono 1 $\mu$ V – 3 mV	1 $\mu$ V – 3 mV	1 $\mu$ V – 3 mV
<b>Muting threshold:</b>	(11.25 – 81.0 dBf)	(11.25 – 81.0 dBf)	(11.25 – 81.0 dBf)
Muting hysteresis 3 dB	5 $\mu$ V	5 $\mu$ V	5 $\mu$ V
<b>Stereo threshold:</b>	(25.2 dBf)	(25.2 dBf)	(25.2 dBf)
Stereo hysteresis 3 dB:	+0.2 dB –0.5 dB	+0.2 dB –0.5 dB	+0.2 dB –0.5 dB
<b>Frequency response 30 Hz to 15 kHz:</b>	Mono +0.2 dB –0.5 dB	+0.2 dB –0.5 dB	+0.2 dB –0.5 dB
	Stereo +0.2 dB –0.5 dB	+0.2 dB –0.5 dB	+0.2 dB –0.5 dB
<b>Distortion at 50 dB quieting:</b>	Mono < 0.1 %	0.2 %	0.9 %
	Stereo 0.1 %	0.3 %	0.8 %
<b>Distortion at 65 dBf: Mono</b>	100 Hz 0.03 %	0.06 %	0.12 %
	1 kHz 0.03 %	0.06 %	0.12 %
	6 kHz 0.03 %	0.055 %	0.25 %
	10 kHz 0.025 %	0.025 %	0.035 %
<b>Distortion at 65 dBf: Stereo</b>	100 Hz 0.04 %	0.05 %	0.08 %
	1 kHz 0.04 %	0.05 %	0.2 %
	6 kHz 0.1 %	0.25 %	1.0 %
	10 kHz 0.1 %	0.7 %	2.0 %
	Mono < 0.1 %	0.15 %	0.5 %
<b>Intermodulation distortion:</b>			
14 kHz mod. 50%, 15 kHz mod. 50%			
Measured 1 kHz in %	Stereo < 0.1 %	0.15 %	0.8 %
<b>Capture ratio:</b>	0.4 dB	1 dB	3 dB
<b>Adjacent channel selectivity <math>\pm</math> 200 kHz:</b>	3 dB	12 dB	40 dB
<b>Alternate channel selectivity <math>\pm</math> 400 kHz:</b>	30 dB	90 dB	> 90 dB
<b>Spurious response ratio:</b>	> 135 dB	> 135 dB	> 135 dB
<b>Image response ratio:</b>	> 135 dB	> 135 dB	> 135 dB
<b>IF-response ratio, balanced:</b>	135 dB	135 dB	135 dB
<b>RF intermodulation:</b>	72 dB	72 dB	72 dB
<b>AM suppression ratio:</b>	> 70 dB	> 70 dB	> 70 dB
<b>Stereo separation:</b>	100 Hz 60 dB	60 dB	55 dB
	1 kHz 70 dB	60 dB	55 dB
	6 kHz 60 dB	50 dB	40 dB
	10 kHz 50 dB	45 dB	35 dB
	95 dB	95 dB	95 dB
	95 dB	95 dB	95 dB
<b>Subcarrier product ratio:</b>	> 120 dB	> 120 dB	> 120 dB
<b>19 kHz suppression:</b>	0.3 $\mu$ V – 1000 $\mu$ V	0.3 $\mu$ V – 1000 $\mu$ V	0.3 $\mu$ V – 1000 $\mu$ V
<b>38 kHz suppression:</b>	1.0 mV – 3000 mV	1.0 mV – 3000 mV	1.0 mV – 3000 mV
<b>Signal meter autorange I:</b>			
<b>Signal meter autorange II:</b>			

#### Optional Extras:

- Black acrylic side walls for freestanding units.
- Attachment sets for installation in 19 inch racks.

● Specifications are subject to change without notice.

**TANDBERG®**  
The European Alternative

Tandberg A/S, Post Office Box 53, N-2007 Kjeller, Norway