

Panel-mounted digital pressure switch

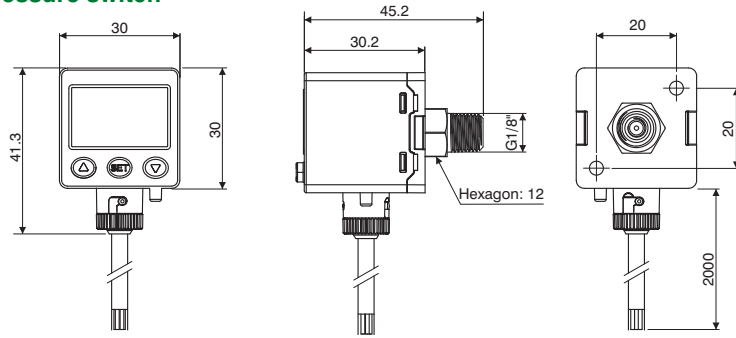

Ordering code	
DS.45.P.U.F3.D.0	
OUTPUTS	
U	E=2 PNP outputs + Analog output (4 / 20 mA)
	L=2 PNP outputs + copy function

Technical features

Working pressure range	0.000 - 1.000 mPa	
Regulation pressure range	-0.100 - 1.000 mPa	
Maximum supported pressure	1.5 mPa	
Allowed fluids	Air, non-corrosive gases, non-combustible gases	
Pressure calibration sensitivity	kPa	0.1
	kgf/cm ²	0.001
	bar	0.001
	psi	0.01
	InHg	0.1
Supply voltage	From 12 to 24 VDC	
Current consumption	≤40mA (without load)	
	PNP N.O. 2 outputs Maximum load current: 125mA Maximum supply voltage: 24VDC Voltage drop: ≤1.5V	
Digital output	± 0.2% Full Scale ± 1 digit	
Repeatability (Digital output)	Settable	
Digital output	Type of hysteresis Hysteresis	from 0.001 to 0.008 bar
Response time	≤2,5 ms (anti-interference function: 25ms, 100ms, 250ms, 500ms, 1000ms and 1500ms selectable)	
Protection from short circuit at output	Present	
Display	Display with 3 1/2 digits (red/Green)	
Indicator precision	±2% F. S. ±1 digit	
Indicator	LED Orange (output1) LED Orange (output2)	
Analog output	Output current: 4÷20mA ±2.5% F. S. Linearity: ±1% F. S.	
	Maximum load resistance: 250Ω supply at 12V and 600Ω supply at 24V Minimum load resistance: 50Ω	
	Protection class	IP65
Ingress protection rating	Ambient temperature	Operational: 0 - 50°C, Storage: -10 - 60°C (without ice or condensation)
	Ambient humidity	Operation/Storage: 35 - 85% (without condensation)
	Supported voltage	1000VAC in 1min. (between body and cable)
	Insulation resistance	50MΩ (at 500VDC, between body and cable)
	Vibration	Total amplitude 1.5mm or 10G, 10Hz-55Hz-10Hz scanning for 1 minute, 2 hours in each direction of X, Y and Z
	Impacts/shocks	100m/s ² (10G), 3 times in each direction of X, Y and Z
Temperature characteristics	±2.5% Full Scale in a range between 0 - 50°C	
Type of connection	G1/8" (BSPP), M5 female	
Electrical cable	Oil resistant cable (internal 0.15mm ²)	
Weight	Approximately 86 gr. (with 2 metres of cable)	

Output circuit wiring scheme

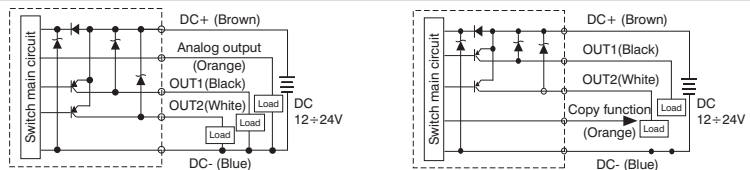

Accessories

Fastening bracket



Ordering code
DS.BT10

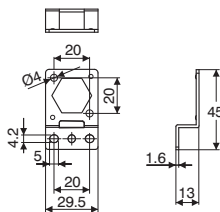

Panel mount adapter



Ordering code
DS.PAE

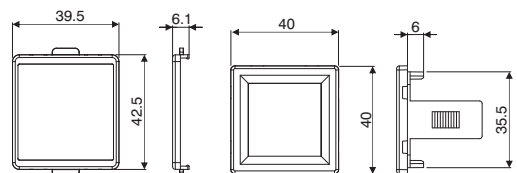

Fastening bracket



Ordering code
DS.BT11

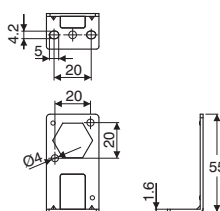

Panel mount adapter with screen protection



Ordering code
DS.PAF

