

FPZ
BLOWER TECHNOLOGY

SERIES K-MS MOR

ATEX II 2G/3G c T3 VERSION

TECHNICAL CHARACTERISTICS

- Aluminium alloy construction
- High efficiency impeller
- Protection treatment of surfaces
- For Group IIB classified gases and Biogas
- Connection for flange PN16 DN50 complying with UNI EN 1092-1

OPTIONS

- Without condensate drain
- Motors IP65
- Special Voltages (IEC 60038)



COMPANY WITH
QUALITY SYSTEM
CERTIFIED BY DNV GL
= ISO 9001 =



Data sheet

LATERAL CHANNEL BLOWERS-EXHAUSTERS

PRESSURE

Mod	N 2900 rpm [kW]	N 3500 rpm [kW]	Q max 2900 rpm [m ³ /h]	Q max 3500 rpm [m ³ /h]	Gr. ³	ΔP max 2900 rpm [hPa](mbar)	ΔP max 3500 rpm [hPa](mbar)	Leq ¹ 2900 rpm (Lp)(dB(A))	Leq ¹ 3500 rpm (Lp)(dB(A))	Weight ² max [kg]
K05-MS	1,5	1,8	207	250	90S	150	125	74,9	75,9	28
	2,2	2,6	207	250	90L	250	225	75,6	77,3	31
K06-MS	3	3,6	305	364	100L	200	175	79,9	81,7	35
	4	4,8	305	364	112L	300	275	81,3	83,4	50

VACUUM

Mod	N 2900 rpm [kW]	N 3500 rpm [kW]	Q max 2900 rpm [m ³ /h]	Q max 3500 rpm [m ³ /h]	Gr. ³	ΔP max 2900 rpm [hPa](mbar)	ΔP max 3500 rpm [hPa](mbar)	Leq ¹ 2900 rpm (Lp)(dB(A))	Leq ¹ 3500 rpm (Lp)(dB(A))	Weight ² max [kg]
K05-MS	1,5	1,8	207	250	90S	150	150	73	75,2	28
	2,2	2,6	207	250	90L	225	225	74,5	77	31
K06-MS	3	3,6	305	364	100L	200	175	73,4	77,9	35
	4	4,8	305	364	112L	225	250	75	79,8	50

SPECIFICATIONS

BLOWER:

- Classification ATEX II 2Gc T3
- Complete with condensate drain

MOTOR:

- Classification ATEX II 3G T3 / 3D T125°C
- Including bimetal thermal switch

INSTALLATION

- For proper operation of the machine it must be equipped with a suction ATEX FILTER.
- Permissible suction and ambient temperature from -15° to +40°C
- Read the instructions carefully before installing the machine
- Data not binding and subject to change without notice
- Horizontal only

¹ Noise measured at 1 m distance with inlet and outlet ports piped, in accordance to ISO 3744.

² Value refers to the weight of the machine with 3 Phase motor if MOR range, without motor if GOR or GVR range.

³ Electric motor's construction form.

N: Installed motor power

Q: Flow rate

ΔP: Differential pressure

Leq: Noise level

PRESSURE

2900 rpm (50 Hz)

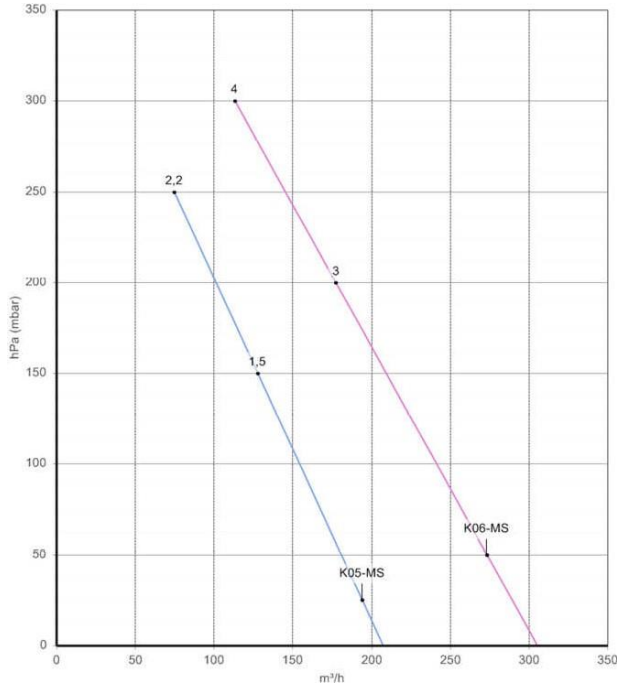

3500 rpm (60 Hz)

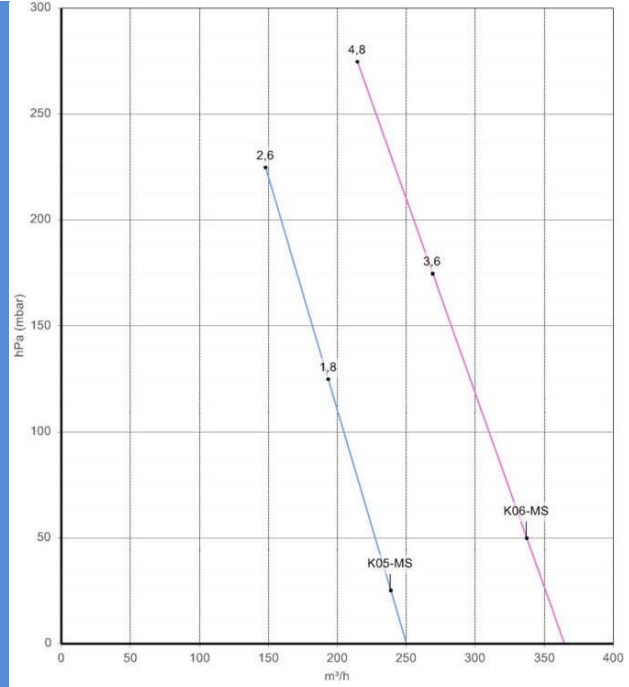

FLOW RATE

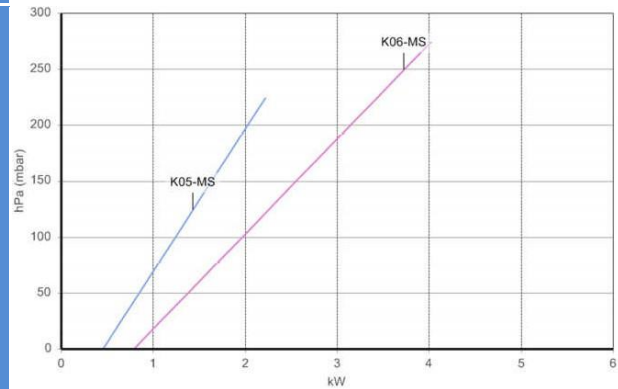
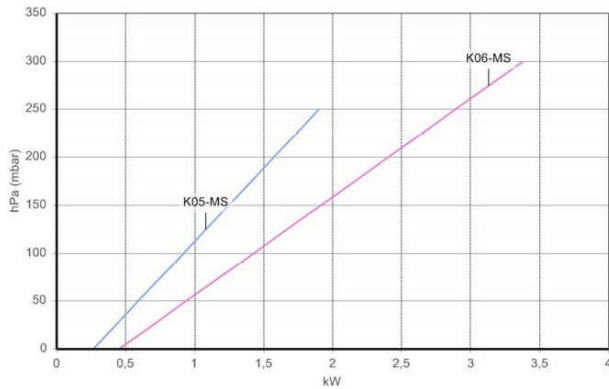

ABSORBED POWER

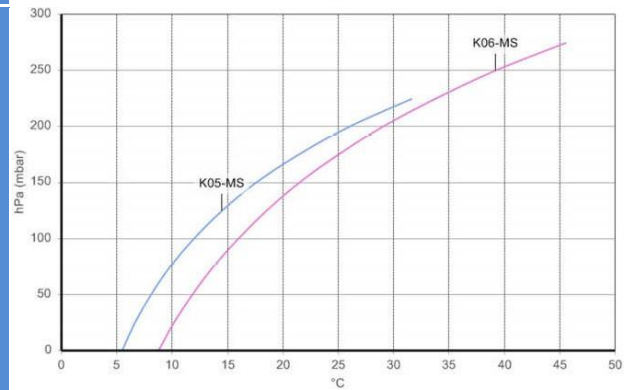
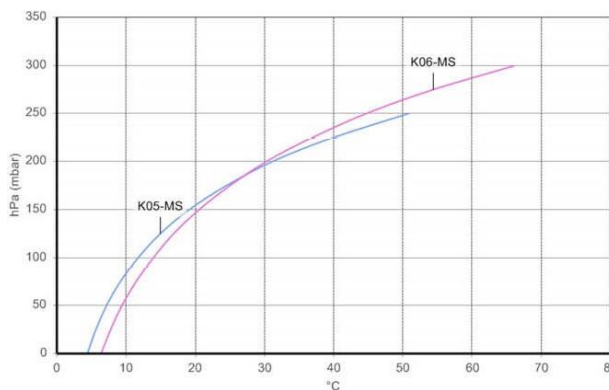

TEMPERATURE INCREASE

Curves refer to air at 20°C (68° F) temperature and 1013 mbar (29.92 In Hg) atmospheric pressure (abs) measured at inlet port.
 Values for flow, power consumption and temperature rise: ±10% tolerance.
 Data can change without prior notice.

VACUUM

2900 rpm (50 Hz)

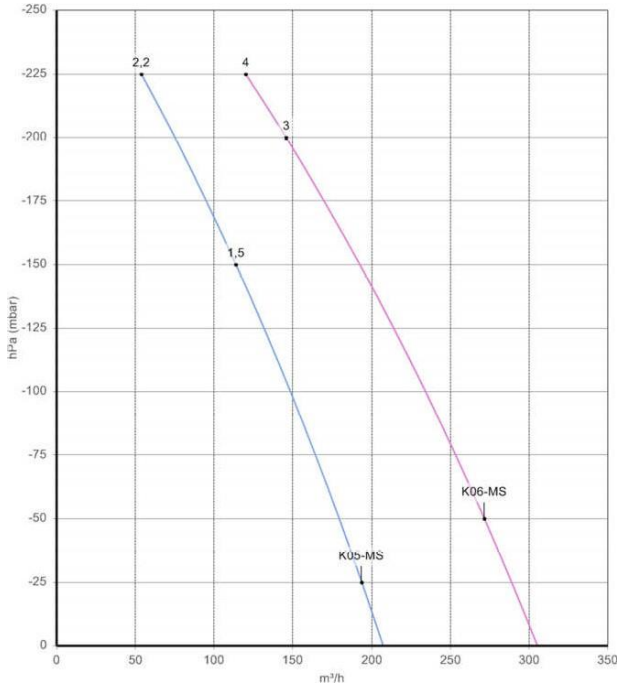

3500 rpm (60 Hz)

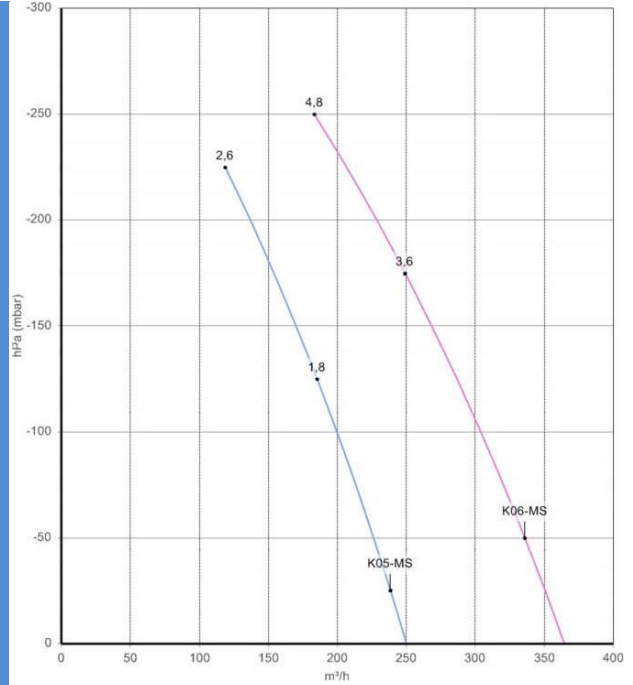

FLOW RATE

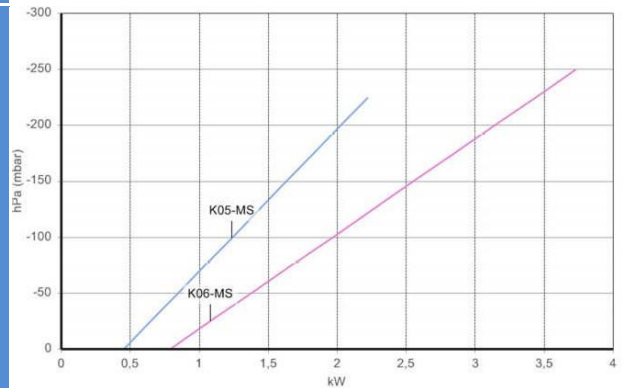
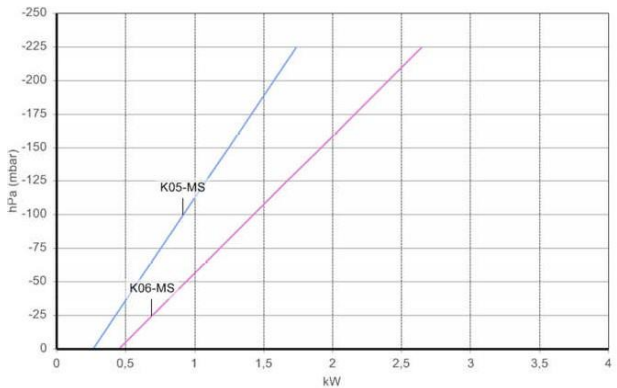

ABSORBED POWER

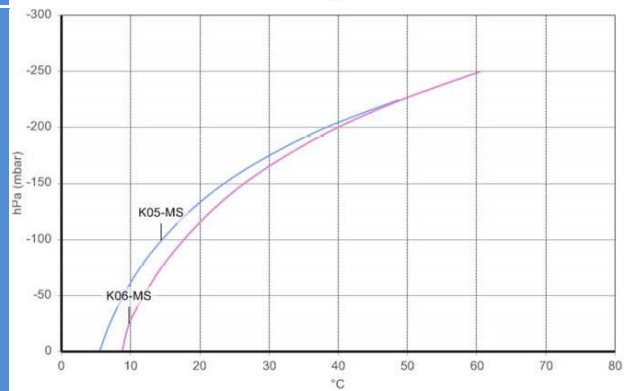
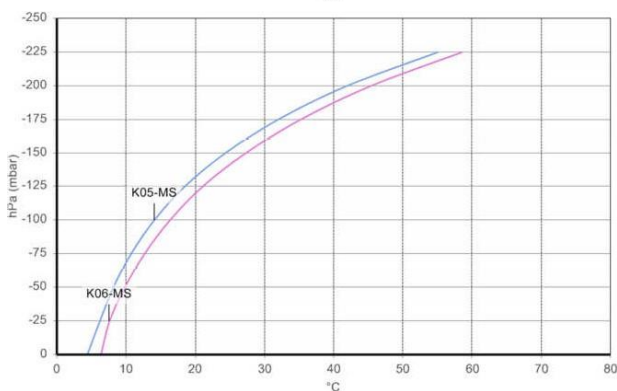

TEMPERATURE INCREASE

Curves refer to air at 20°C (68° F) temperature and 1013 mbar (29.92 In Hg) atmospheric pressure (abs) measured at inlet port.
 Values for flow, power consumption and temperature rise: ±10% tolerance.
 Data can change without prior notice.

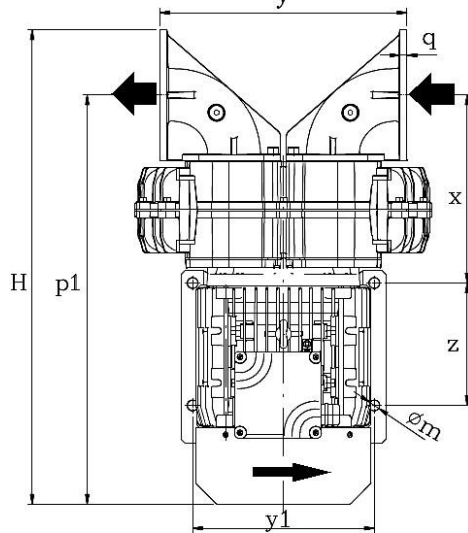
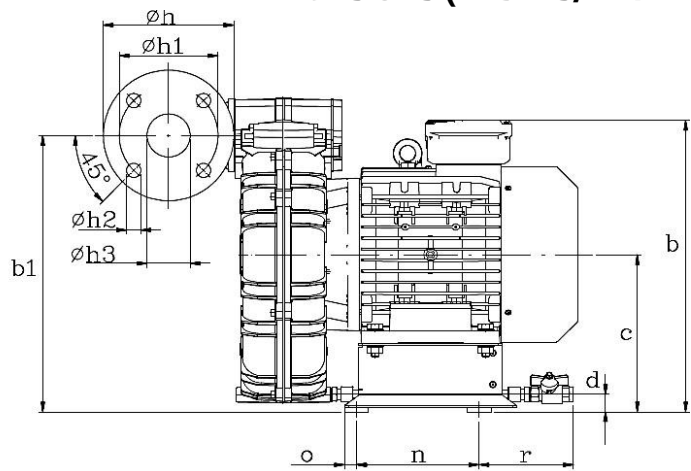
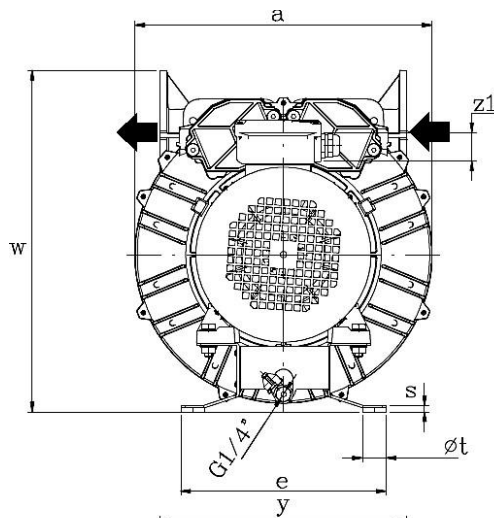
DIMENSIONS (K05-MS/K06-MS)

Dimensions in mm - FOR REFERENCE ONLY

Mod	M.E.	a	b	b1	c	d	e	H	h
K05-MS	90S	327	336	334	189	35	260	552	165
K05-MS	90L	327	336	334	189	35	260	552	165
K06-MS	100L	376	353	350	199	22	260	582	165
K06-MS	112M	376	369	350	199	22	260	601	165

Mod	h1	h2	h3	m	n	o	p1	q	r
K05-MS	125	18	54,5	13	155	43	469	9	97
K05-MS	125	18	54,5	13	155	43	469	9	97
K06-MS	125	18	54,5	13	155	20	499	9	120
K06-MS	125	18	54,5	13	155	15,5	518	9	120

Mod	s	t	w	x	y	y1	z	z1
K05-MS	8	30	416	240	308	230	155	M20X1.5
K05-MS	8	30	416	240	308	230	155	M25X1.5
K06-MS	8	30	432	238	313	230	155	M25X1.5
K06-MS	8	30	433	238	313	230	155	M25X1.5