

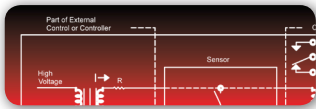

A full spectrum of sensing and signaling products for protection, detection, and safety



-  **SWITCH PRODUCTS**
-  **SAFETY & SIGNAL MATS**
-  **SENSING EDGES**
-  **SENSING BUMPERS**
-  **SAFETY INTERFACE MODULES**
-  **LIGHT CURTAINS & LASER SCANNER**
-  **CUSTOM DESIGNS**
-  **SAFETY INTERLOCKS**



pg. 2 **Using Sensing Edges in Safety Applications**

How sensing edges work
Understanding the fail-safe concept



pg. 3 **TS-6 & TS-16 Mini Sensing Edges**

Low profile with high sensitivity
Immediate activation, no overtravel (TS-6)
Immediate activation, 1/4 inch overtravel (TS-16)



pg. 4 **TS-8 & TS-18 Mini Sensing Edges**

Low profile, end caps available
Immediate activation, no overtravel (TS-8)
Immediate activation, 1/4 inch overtravel (TS-18)



pg. 5 **TS-26 Sensing Edge**

Small profile, end caps available
Compliance before actuation, 3/8 inch overtravel



pg. 6 **TS-46 Sensing Edge**

Medium profile, crimp-on mounting channel, end caps available
Compliance before actuation, 3/4 inch overtravel



pg. 7 **TS-48 Sensing Edges**

Medium profile, snap-in mounting channel, end caps available
Compliance before actuation, 3/4 inch overtravel



pg. 8 **TS-47 & TS-57 Sensing Edges**

High sensitivity for fastest activation
Substantial overtravel for maximum cushioning



pg. 9 **TS-67 Sensing Edge**

High sensitivity from any direction
Immediate actuation with 1 inch overtravel



pg. 10 **TS-108 & TS-109 Sensing Edges**

Self-mounting, side activation, 50 percent overtravel
For residential and commercial application



pg. 11 **How To Order Sensing Edges**

Step-by-step guide to the ordering process



pg. 13 **Compatible Interface Controllers for Safety Applications**

While every effort has been made to ensure the accuracy of the information provided, no liability can be taken for any errors or omission. Tapeswitch Corporation reserves the right to alter specifications and introduce improvements without prior notice.

How sensing edges work

Understanding the fail-safe concept

Tapeswitch pressure-sensitive edges are used to protect personnel and equipment. When pushed or struck, they provide a contact closure that can be used to signal a machine controller. These edges are highly sensitive and feature press-at-any-point actuation. Properly installed and connected, they continuously monitor the protected area. However, to properly function as safety devices, edges must be installed with a fail-safe monitoring circuit as shown below or with an equivalent fail-safe methodology. Tapeswitch Offers Controllers that employ the fail-safe concept.

Understanding and Implementing the 4 conductor fail-safe Concept Principle of Safety

The fail-safe concept monitors the sensor status at all times. In the event of a failure, the fail-safe concept will simulate a protected position. The “protected” position is when the sensor is activated (closed) and the “normal” or “run” position is when the sensor is not activated (open).

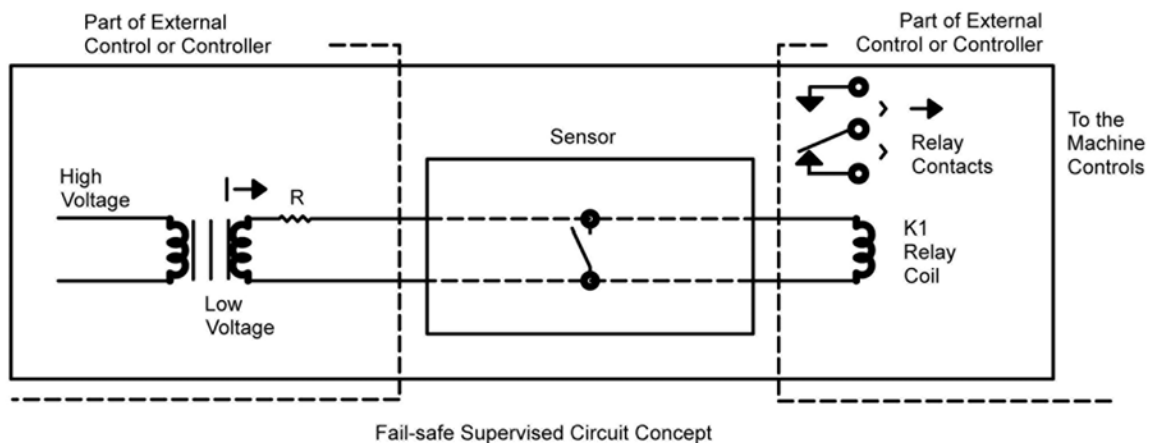

- Normal Conditions – constant current flow (I) holding relay coil (K1) energized
- Loss of Power – no current flow (I) and relay coil (K1) is de-energized
- Actuation of Sensor – relay coil (K1) is shorted and de-energized
- Failure of Sensor in the closed position – relay coil (K1) is shorted and de-energized
- Failure of Sensor in the open position – (broken wire, severed switch or conductor) leaves no path for current flow (I) and relay coil (K1) is de-energized
- Resistor R – limits current flow through the sensor when actuated

Fail-safe (4 conductor)

Fail-safe is a shorthand term used to mean Fail to a Safe condition. In machinery with known hazards, the system is fail-safe when any failure leaves the machinery in a safe condition. The 4 conductor fail-safe concept is illustrated in the figure above. A small current is constantly flowing through the sensor at all times, holding the relay coil energized at all times. The machine controls, interrupt, or stop circuitry is connected to the contacts of this relay. If the sensor is actuated the relay coil will be shorted, causing the relay to de-energize. A resistor in series provides current limiting from overdrawing the power supply and limits the current through the sensor in the actuated position. If the sensor fails in the closed position the relay will be shorted and cannot be energized until the failure is corrected. If the sensor fails in the open position, the current path for the relay coil no longer exists and the relay coil cannot be energized until the current path is restored and the failure corrected.

In addition to the safety aspects achieved with fail-safe, it also provides:

- Isolation of the machine controls and sensor(s)
- Isolation of high amperage and high voltage machine switching from the low voltage sensors
- Conversion of a normally open switch to required normally closed machine controls

While every effort has been made to ensure the accuracy of the information provided, no liability can be taken for any errors or omission. Tapeswitch Corporation reserves the right to alter specifications and introduce improvements without prior notice.

TS-6 & TS-16 MINI SENSING EDGES

Low profile with high sensitivity

Immediate actuation, no overtravel (TS-6)

Immediate actuation, 1/4 inch overtravel (TS-16)



TS-6 & TS-16 Mini Sensing Edges are designed for limited space applications requiring high-sensitivity. These two products differ mainly in height and sensitivity. The TS-6 is 5/16 inch high and requires only 1.5 pounds to activate, while the TS-16 is 9/16 inch high and requires 2.2 lbs to activate.

These edges have PVC housings, which are resistant to water, oil, hydraulic fluids, and coolants. The internal switching elements are rated for millions of operations at any point. They mount in snap-in channel that is available in two configurations: flat (aluminum or PVC) or with a right-angle mounting edge (aluminum only). All TS-6 and TS-16 Sensing Edges are supplied with 4 conductor, fail-safe wiring and are compatible with

Tapeswitch Interface Controllers.

Features & Benefits

- Low profile for limited space applications
- High sensitivity, low compliance for immediate activation
- Some overtravel allows compression after activation (TS-16 only)
- Standard 4 conductor fail-safe wiring

Drawings

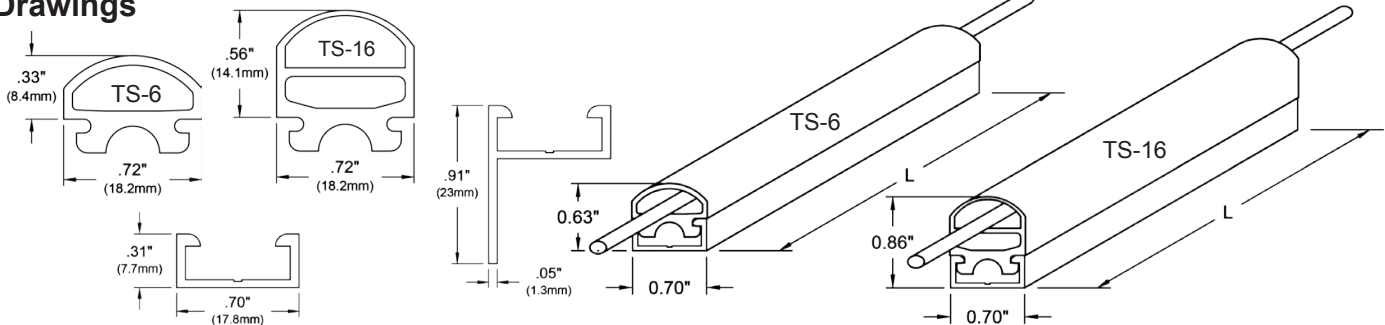

Typical Applications

- Pinch protection on scissor lifts
- Obstruction detection on automatic doors
- Personnel protection on automated storage systems
- Impact detection on machinery edges
- Patient protection on medical tables
- Residential and commercial sensing applications

Specifications

Actuation Force	1.5 lbs (6.7 N) nominal for TS-6 2.2 lb (9.8 N) nominal for TS-16
Overtravel	0.04 in. (1 mm) after activation for TS-6 0.20 in. (5 mm) after activation for TS-16
Recommended Voltage & Current	28 VAC or VDC at 1.0 amps max.
Exterior Housing	PVC
Mounting Options	Aluminum channel (flat or angle) PVC channel (flat only)
Colors	TS-6 Black, Red & Yellow TS-16 Black, Red & Yellow
Lead Wiring	2 x 22/2 AWG, 4-Conductor fail-safe, 18 in. long

While every effort has been made to ensure the accuracy of the information provided, no liability can be taken for any errors or omission. Tapeswitch Corporation reserves the right to alter specifications and introduce improvements without prior notice.

TS-8 & TS-18 MINI SENSING EDGES

Low profile, end caps available

Immediate actuation, no overtravel (TS-8)

Immediate actuation, 1/4 inches overtravel (TS-18)



TS-8 & TS-18 Mini Sensing Edges are designed for limited space applications where end caps are desirable for cosmetic or environmental reasons. These two products differ mainly in housing material: PVC for the TS-8 and EPDM for the TS-18. The EPDM housings have better chemical resistance and have a wider temperature range than PVC.

Mounting for both edges is by means of snap-in aluminum channel. The internal switching element is rated for millions of operations at any point. All TS-8 & TS-18 Sensing Edges are supplied with 4 Conductor, fail-safe wiring and are compatible with Tapeswitch Interface Controllers.

Features & Benefits

- Low profile for limited space applications
- End caps for cosmetic or environmental concerns
- Some overtravel allows compression after activation (TS-8 only)
- Standard 4 conductor fail-safe wiring

Drawings

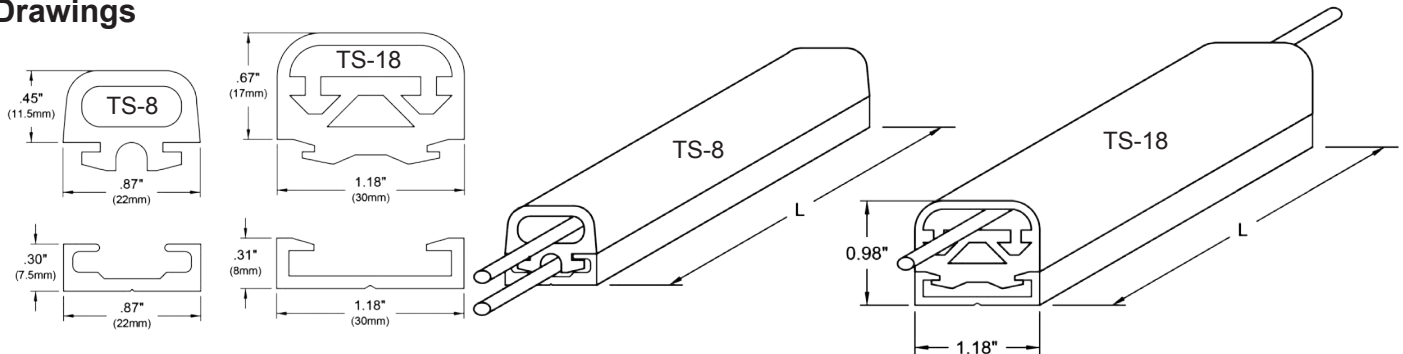

Typical Applications

- Pinch protection on machinery edges
- Obstruction detection on medical tables
- Signaling on machining centers
- Personnel protection from moving equipment
- Activation or deactivation of powered storage systems
- Applications requiring a large active switching surface

Specifications

Actuation Force	2.5 lbs (11 N) nominal for TS-8 3.0 lb (13 N) nominal for TS-18
Overtravel	0.10 in. (3 mm) after activation for TS-8 0.25 in. (6 mm) after activation for TS-18
Recommended Voltage & Current	28 VAC or VDC at 1.0 amps max.
Exterior Housing	PVC for TS-8 EPDM for TS-18
Mounting Options	Flat aluminum channel
Colors	Black
Lead Wiring	2 x 22/2 AWG, 4-Conductor fail-safe, 18 in. long

While every effort has been made to ensure the accuracy of the information provided, no liability can be taken for any errors or omission. Tapeswitch Corporation reserves the right to alter specifications and introduce improvements without prior notice.

TS-26 SENSING EDGES

Medium profile, end caps available
Immediate actuation, 3/8 inch overtravel



The **TS-26 Sensing Edge** is a general-purpose, medium profile, pressure-sensitive edge. It provides minimum compliance before activation, and about 3/8 inch of overtravel cushioning after activation. This product is excellent for applications requiring side activation. TS-26 Edges are available in two mounting configurations: snap-in channel-mount (flat or angle), clamp-mount.

Housing is Santoprene TPE (TS-26 and TS-26T). Both materials are resistant to water, oil, hydraulic fluids, and coolants. The internal switching elements are rated for millions of operations at any point. All TS-26 Sensing Edges are supplied with 4 conductor, fail-safe wiring and are compatible with Tapeswitch Interface Controllers.

Features & Benefits

- Low compliance for immediate activation
- 35 percent overtravel after activation
- Excellent side activation properties
- Standard 4 conductor fail-safe wiring

Drawings

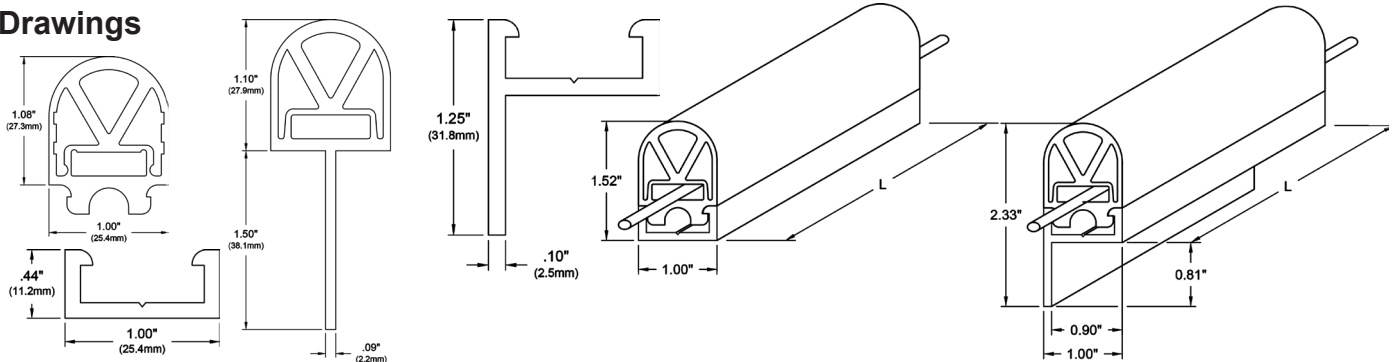

Typical Applications

- Pinch protection on machinery edges
- Obstruction detection on medical tables
- Collision sensors on AGVs
- Obstruction detection on automatic doors and gates
- Contact sensing on large moving machinery
- Applications requiring side activation

Specifications

Actuation Force	4.5 lbs (20 N) nominal
Overtravel	0.35 in. (9 mm) after activation
Recommended Voltage & Current	28 VAC or VDC at 1.0 amps max.
Exterior Housing	Santoprene TPE for TS-26 and TS-26T
Mounting Options	Aluminum channel (flat or angle) for TS-26 PVC channel (flat only) for TS-26 Clamp mounting for TS-26T only
End Caps	End caps are black
Colors	TS-26 Black, Red & Yellow TS-26T Red
Lead Wiring	2 x 20/2 AWG, Dri-Run, 72 in. long, 3/16 in. dia.

While every effort has been made to ensure the accuracy of the information provided, no liability can be taken for any errors or omission. Tapeswitch Corporation reserves the right to alter specifications and introduce improvements without prior notice.



TS-46 SENSING EDGES

Medium profile, crimp-on mounting

Compliance before actuation, 3/4 inch overtravel



The TS-46 Sensing Edge is a general purpose, medium profile edge. It has some compliance before activation, eliminating nuisance tripping, and provides about 3/4 inch of overtravel cushioning after activation. This edge also exhibits excellent side activation. Mounting is in crimpable aluminum channel (crimped, flat or angle), which is more tamper-resistant than snap-in channel.

The Santoprene TPE housing is resistant to water, oil, hydraulic fluids, and coolants. The internal switching element is rated for millions of operations at any point. All TS-46 Sensing Edges are supplied with 4 conductor, fail-safe wiring and are compatible with Tapeswitch Interface Controllers.

Features & Benefits

- Compliance before activation eliminates nuisance tripping
- 3/4 inch overtravel provides cushioning after activation
- Excellent side activation properties
- Standard 4 conductor fail-safe wiring

Drawings

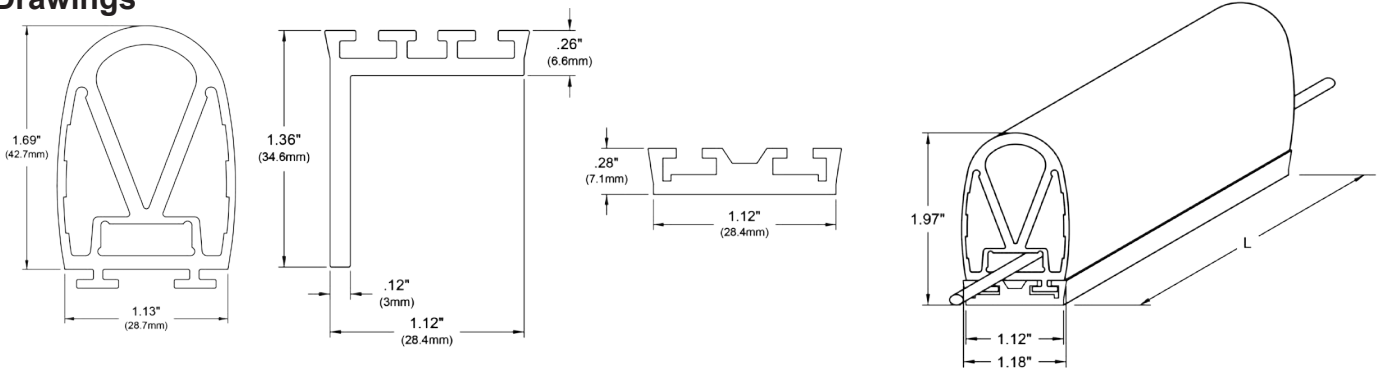

Typical Applications

- Obstruction detection on powered doors and gates
- Collision detection on moving platforms
- Positioning control on moving conveyors
- Pinch protection on stage lifts
- Collision sensors on AGVs
- General applications for small sensing bumpers

Specifications

Actuation Force	10 lbs (44 N) nominal
Overtravel	0.75 in. (19 mm) after activation
Recommended Voltage & Current	28 VAC or VDC at 1.0 amps max.
Exterior Housing	Santoprene TPE
Mounting Options	Aluminum crimpable channel (flat or angle)
Colors	Black, Red & Yellow
Lead Wiring	2 x 20/2 AWG, Dri-Run, 72 in. long, 3/16 in. dia.

While every effort has been made to ensure the accuracy of the information provided, no liability can be taken for any errors or omission. Tapeswitch Corporation reserves the right to alter specifications and introduce improvements without prior notice.

TS-48 SENSING EDGES

Medium profile, snap-in mounting

Compliance before actuation, 3/4 inch overtravel



The **TS-48 Sensing Edge** is a general purpose, medium profile edge. It activates after some compliance, eliminating nuisance tripping, and provides about 3/4 inch of overtravel cushioning after activation. Mounting is by means of snap-in channel that is available in three configurations: Flat (aluminum or PVC) and with a straight or right angle flange (aluminum only).

The Santoprene TPE housing is resistant to water, oil, hydraulic fluids, and coolants. The internal switching element is rated for million of operations at any point. All TS-48 Sensing Edges are supplied with 4 conductor, fail-safe wiring and are compatible with Tapeswitch Interface Controllers.

Features & Benefits

- Compliance before activation eliminates nuisance tripping
- 3/4 inch overtravel provides cushioning after activation
- Excellent side activation properties
- Standard 4 conductor fail-safe wiring

Drawings

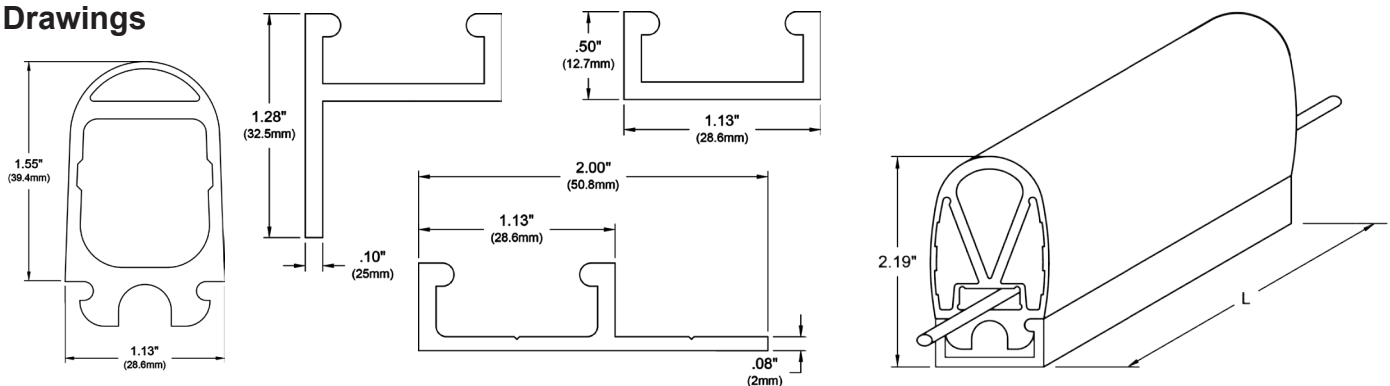

Typical Applications

- Obstruction detection on powered doors and gates
- Collision detection on moving platforms
- Positioning control on moving conveyors
- Pinch protection on stage lifts
- Collision sensors on AGVs
- General applications for small sensing bumpers

Specifications

Actuation Force	10 lbs (44 N) nominal
Overtravel	0.75 in. (19 mm) after activation
Recommended Voltage & Current	28 VAC or VDC at 1.0 amps max.
Exterior Housing	Santoprene TPE
Mounting Options	Aluminum channel (flat, angled or flanged), PVC channel (flat only)
Colors	Black, Red & Yellow
Lead Wiring	2 x 20/2 AWG, Dri-Run, 72 in. long, 3/16 in. dia.

While every effort has been made to ensure the accuracy of the information provided, no liability can be taken for any errors or omission. Tapeswitch Corporation reserves the right to alter specifications and introduce improvements without prior notice.

TS-47 & TS-57 SENSING EDGES

High sensitivity, no compliance for fastest activation
Substantial overtravel for maximum cushioning



The **TS-47 & TS-57 Sensing Edges** are designed for powered doors and other applications requiring the most sensitive switching and the fastest activation. These two products differ mainly in overall height and the amount of overtravel cushioning. Mounting is by means of snap-in channel that is available in three configuration: Flat (aluminum or PVC) and with a straight or right-angle flange (aluminum only).

The Santoprene TPE housings are resistant to water, oil, hydraulic fluids, and coolants. The internal switching elements are rated for millions operations at any point. All TS-47 and TS-57 Sensing Edges are supplied with 4 conductor, fail-safe wiring and are compatible with Tapeswitch Interface Controllers.

Features & Benefits

- High sensitivity with no compliance for fastest activation
- Substantial overtravel provides maximum cushioning after activation
- Specifically designed for powered doors and gates
- Standard 4 conductor fail-safe wiring

Drawings

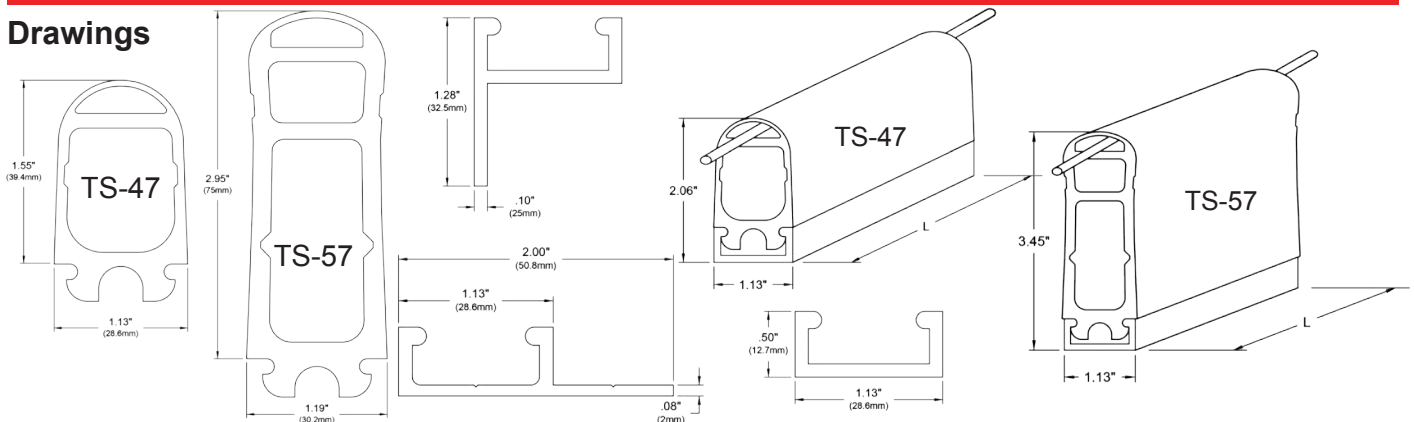

Typical Applications

- Personnel protection from power driven doors and gates
- Side bumpers on AGVs and mobile platforms or machinery
- Obstruction detection on high-speed, gym doors, and moving partitions
- General sensing applications requiring fast response and protective cushioning

Specifications

Actuation Force	1.2 lbs (5.3 N) nominal
Overtravel	1.0 in. (25 mm) after activation for TS-47 1.77 in. (45 mm) after activation for TS-57
Recommended Voltage & Current	28 VAC or VDC at 1.0 amps max.
Exterior Housing	Santoprene TPE
Mounting Options	Aluminum channel (flat, angled or flanged), PVC channel (flat only)
Colors	TS-47 Black & Red TS-57 Black, Red & Yellow
Lead Wiring	2 x 20/2 AWG, Dri-Run, 72 in. long, 3/16 in. dia.

While every effort has been made to ensure the accuracy of the information provided, no liability can be taken for any errors or omission. Tapeswitch Corporation reserves the right to alter specifications and introduce improvements without prior notice.

TS-67 OMNI-DIRECTIONAL SENSING EDGE

High sensitivity from any direction

Immediate actuation with 1 inch overtravel



The **TS-67 Sensing Edge** is a unique, dual-switch product that exhibits uniform high sensitivity when deflected in any direction – top, side, or at an angle. After actuation, it provides 1 inch of protective overtravel cushioning. Mounting is by means of snap-in PVC channel. The internal switching elements are rated for millions of operations at any point.

Originally designed for the specialized requirements of revolving doors, the TS-67 is suitable for any application requiring a highly sensitive and flexible edge. It is especially appropriate when the direction of impact is unpredictable. TS-67 Sensing Edges are supplied with 4 conductor, fail-safe wiring and are compatible with Tapeswitch Interface Controllers.

Features & Benefits

- Dual-switch design for high sensitivity in all directions
- Immediate activation for maximum protection
- 1 inch overtravel provides cushioning after activation
- Standard 4 conductor fail-safe wiring

Drawings

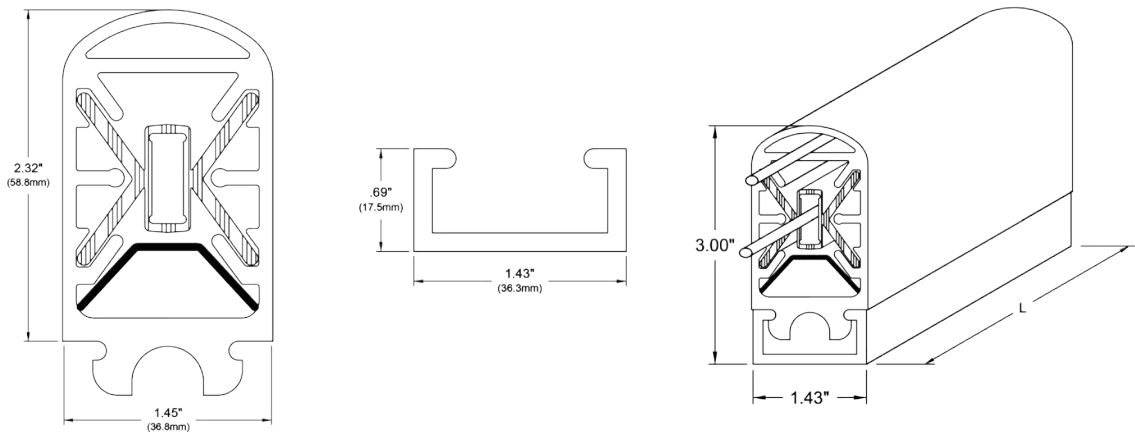

Typical Applications

- Revolving doors or swinging gates
- Swinging doors on machinery
- Pinch protection on sliding surfaces
- Fast-moving powered closures
- Impact detection on moving machinery
- Applications requiring multi-directional sensing

Specifications

Actuation Force	6.0 lbs (27 N) nominal
Overtravel	1.0 in. (25 mm) after activation
Recommended Voltage & Current	28 VAC or VDC at 1.0 amps max.
Exterior Housing	Santoprene TPE
Mounting Options	PVC snap-in channel
Colors	Black
Lead Wiring	2 x 20/2 AWG, Dri-Run, 72 in. long, 3/16 in. dia.

While every effort has been made to ensure the accuracy of the information provided, no liability can be taken for any errors or omission. Tapeswitch Corporation reserves the right to alter specifications and introduce improvements without prior notice.



TS-108 & TS-109 SENSING EDGES

Self-mounting, side activation, 50% overtravel
For residential and commercial applications



The **TS-108 & TS-109 Sensing Edges** are designed for mounting directly on door or stage edges without using channel. They have excellent side activation and about 50 percent overtravel cushioning. The TS-109 fits edges from 3/4 inch to 1-1/4 inches thick, and the TS-108 fits edges from 7/8 inch to 2-1/4 inches thick.

The EPDM rubber housings are rugged and weatherproof. The sealed ribbon switch sensing elements are rated for a long life of millions of operations at any point, and are field replaceable, just in case. All TS-108 & TS-109 Sensing Edges are supplied with 4 conductor, fail-safe wiring and are compatible with Tapeswitch Interface Controllers.

Features & Benefits

- Self-mounting eliminates need for channel
- Side activation maximizes protection
- Replaceable switching element simplifies maintenance
- Standard 4 conductor fail-safe wiring

Drawings

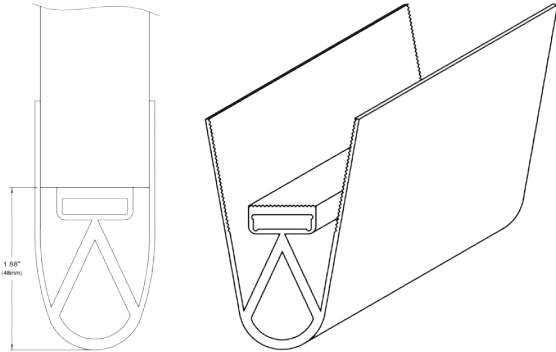

The TS-108 fits edges 7/8" to 2-1/4" thick

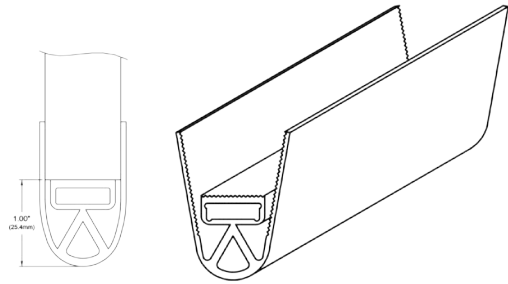

The TS-109 fits edges 3/4" to 1-1/4" thick

Typical Applications

- Personnel protection from power driven doors, gates, and partitions
- Pinch point protection on stage lifts and scenery elevators
- General residential and commercial sensing applications

Specifications

Actuation Force	5 lbs (22 N) nominal
Overtravel	1.0 in. (25 mm) after activation for TS-108 0.5 in. (12 mm) after activation for TS-109
Recommended Voltage & Current	28 VAC or VDC at 1.0 amps max.
Exterior Housing	EPDM rubber
Mounting Options	Contact cement, tacks, staples, batten strip or molding
Colors	Black
Lead Wiring	2 x 20/2 AWG, Dri-Run, 72 in. long, 3/16 in. dia.

While every effort has been made to ensure the accuracy of the information provided, no liability can be taken for any errors or omission. Tapeswitch Corporation reserves the right to alter specifications and introduce improvements without prior notice.

HOW TO ORDER SENSING EDGES

Step-by-step guide to the ordering process

When ordering a sensing edge, you need to specify the following items:

1. Product model number
2. Sensing edge color
3. Sensing edge length
4. Mounting channel type
5. Lead style (fail-safe, single lead or single lead with termination resistor)
6. Lead exit location
7. End caps (optional)
8. Connectors (optional)

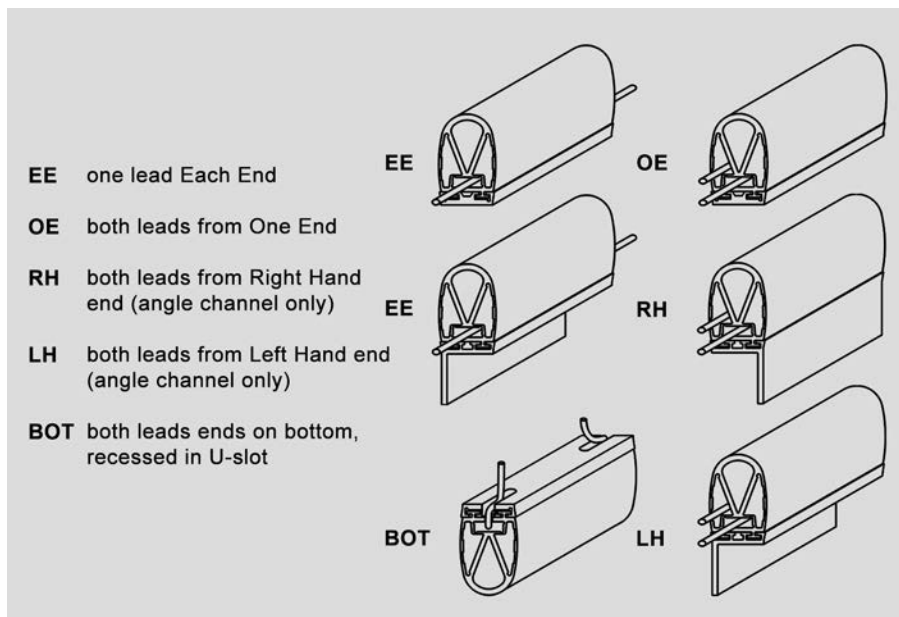

Use the lead illustration above and the table on the facing page to generate a product description as shown in the following example. For lead style, use F/S for fail-safe and S/L for single lead.

Example:

For a TS-26 edge, in red, that is 12 ft. long and mounted in aluminum flat channel, has fail-safe leads with leads out one end, the description code would be as follows:

TS-26, R, 12 ft., AF, F/S, OE

Example:

For a TS-46 edge, in black, that is 10 ft. long and mounted in aluminum angle channel, has fail-safe leads with leads out one end (select left or right hand with angle channel) with a connector, the description code would be as follows:

TS-46, B, 10 ft., AA, F/S, RH, Connector

Definition of terms

Profile

The cross-section of the sensing edge. It varies in height and width, number of compartments, and mechanical elements, all of which determine the actuation characteristics.

Actuation Force

The amount of force necessary to cause a contact closure of the switching element inside the sensing edge using an object of specific size. Tapeswitch actuation forces are measured using a 3/4 inch diameter disc.

Compliance

The amount of deformation of the sensing edge before the switch actuates. Low compliance is desirable when immediate actuation is required. Higher compliance gives some immunity to false or inadvertent actuations.

Overtravel

The amount of deformation of the sensing edge after the switch actuates. Overtravel determines the amount of cushioning after an impact with the edge.

While every effort has been made to ensure the accuracy of the information provided, no liability can be taken for any errors or omission. Tapeswitch Corporation reserves the right to alter specifications and introduce improvements without prior notice.

HOW TO ORDER SENSING EDGES

Use the Product Chart below as guide in specifying your sensing edge.

Product Type	Housing Colors	Available Lengths	Standard Lead Exit*	Standard Lead Wire	Channel Type Option	End Cap
TS-6	B-Black R-Red Y-Yellow	6 in. - 16 ft.	EE - Each End	22/2 AWG 18 in. long	AF-Aluminum Flat AA-Aluminum Angle* PF-PVC Flat	Available
TS-16	B-Black R-Red Y-Yellow	6 in. - 16 ft.	OE - One End	22/2 AWG 18 in. long	AF-Aluminum Flat AA-Aluminum Angle* PF-PVC Flat	Available
TS-8 TS-18	B-Black	6 in. - 21 ft.	EE - Each End	22/2 AWG 18 in. long	PF-PVC Flat	Available
TS-26	B-Black R-Red Y-Yellow	6 in. - 16 ft.	OE - One End	22/2 AWG 18 in. long	AF-Aluminum Flat AA-Aluminum Angle*	Available
TS-26T	R-Red	6 in. - 16 ft.	OE - One End	20/2 AWG Dri-Run 72 in. long, 3/16 in. dia.	None required	Not Available
TS-46	B-Black R-Red Y-Yellow	6 in. - 16 ft.	OE - One End	20/2 AWG Dri-Run 72 in. long, 3/16 in. dia.	AF-Aluminum Flat AA-Aluminum Angle*	Available
TS-48	B-Black R-Red Y-Yellow	6 in. - 16 ft.	OE - One End	20/2 AWG Dri-Run 72 in. long, 3/16 in. dia.	AF-Aluminum Flat AA-Aluminum Angle* AS-Aluminum Flange* PF-PVC Flat	Available
TS-47 TS-57	B-Black R-Red Y-Yellow (TS-57)	6 in. - 16 ft.	OE - One End	20/2 AWG Dri-Run 72 in. long, 3/16 in. dia.	AF-Aluminum Flat AA-Aluminum Angle* AS-Aluminum Flange* PF-PVC Flat	Available
TS-67	B-Black	6 in. - 9 ft.	OE - One End	20/2 AWG Dri-Run 72 in. long, 3/16 in. dia.	PF-PVC Flat	Not Available
TS-108 TS-109	B-Black	6 in. - 10 ft.	OE - One End	20/2 AWG Dri-Run 72 in. long, 3/16 in. dia.	None required	Not Available

* When using angle or flange channel, specify LH or RH lead exit.

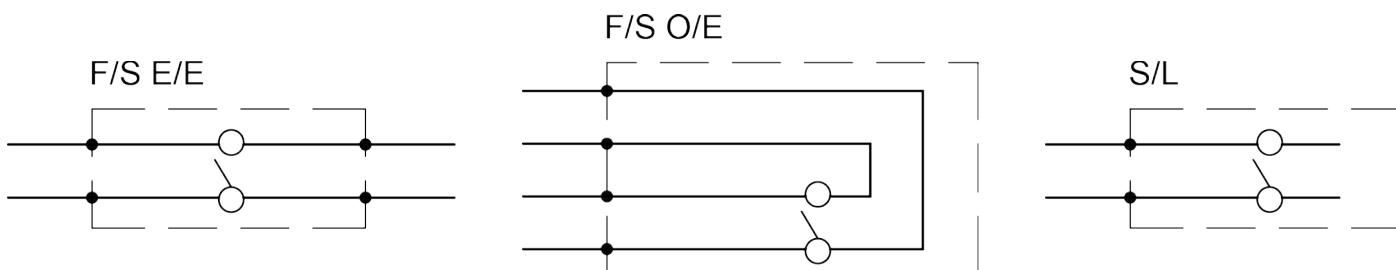

While every effort has been made to ensure the accuracy of the information provided, no liability can be taken for any errors or omission. Tapeswitch Corporation reserves the right to alter specifications and introduce improvements without prior notice.

SAFETY INTERFACE MODULES FOR EDGES

Tapeswitch manufactures Safety Interface Modules (SIM) that are compatible with all of the **Sensing Edge** products shown in this catalog. These devices provide an interface between the low-voltage **Sensing Edges** and the machine or device being controlled. Be certain to select the appropriate controller for the application. For detailed specifications, see our catalog for Interface Controllers, or visit www.tapeswitch.com.

Safety applications require the use of both a fail-safe **sensing edge** and a fail-safe rated Interface Controller. For non-safety applications, any mix of fail-safe and non fail-safe devices may be used.

PCU/1 Control Unit - Programmable control unit.

This controller allows for the connection, control, and streamlining of multiple safety devices with programmable logic control functions, such as safety sensors and signals, light curtains, safety photocells, e-stops, safety mats, sensing edges, sensing bumpers, two-hand controls, magnetic or mechanical switches. Check website for category and SIL safety level. The easy to use software allows for multiple functions and logic controls and has a configurable memory a list of input and output objects for a user friendly interface. It is USB capable for connection to the most common industrial Fieldbus systems for diagnostics and data communication. The stand alone controller has 8 input, 2 OSSD pairs, 4 test outputs, 2 digital signaling outputs, 2 inputs for restart, and 24 connectors, plus several different expansion units for additional inputs, outputs, and signaling and connectors plus additional safety relays.



PSSR/2 Control Unit - Fail-safe controller for end of the line resistor products.

The PSSR/2 safety interface controller is designed for 1 or 2 input sensors and offers Category 3, SIL2, PLd safety level performance and meets EN13849-1:2008. It is self monitoring and offers integrity monitoring of any 6.8 to 8.2 k ohm end of the line resistor product, such as switches, mats, and edges that incorporate a 6.8 to 8.2 k ohm resistor, making a complete safety system. It has forced guided relays and 2 normally open (safety) and 1 normally closed (monitor) contacts. It has a manual or auto reset function. It has a maximum sensor length of 330 feet. It is 22.5 mm din rail mountable.



PRSU Control Units - Our most compact fail-safe module.

For high-risk automation and machine control applications. Compatible with all Tapeswitch sensing products, including switches, edges, bumpers, and mats. Conforms to EN 13849-1 safety performance level PLd, Category 3, and meets or exceeds the safety content of the applicable OSHA, ANSI, and RIA standards.

Available in a DIN rail-mounted package, with two power options. PRSU/4 operates on 24 VDC or VAC supply, PRSU/5 operates on 115 VAC supply. Both models feature manual and automatic reset capability.



MZ-Series MultiZone Controller - Custom designs for custom controls.

Acts as an interface between various Tapeswitch sensing devices and a machine or process control. Designed to monitor up to 6 zones and provides power to all connected B-Series Light Curtains emitters and receivers and monitors the output signals. Also interfaces with a variety of pressure sensitive, normally-open switches made by Tapeswitch, including ribbon switches, safety mats, sensing edges and bumpers.



PSSU Control Units - 4 fail-safe models in 2 package styles.

For automation and machine control applications. These controllers exceed the requirements of category 3 of EN 954-1 and meet or exceed the safety content of the applicable OSHA, ANSI, and RIA standards. Available in wall-mounted and DIN rail-mounted versions with voltage options of 110/240 VAC or 24 VDC operation. Auto or manual reset, depending on model.



While every effort has been made to ensure the accuracy of the information provided, no liability can be taken for any errors or omission. Tapeswitch Corporation reserves the right to alter specifications and introduce improvements without prior notice.