

<h1>SPECIFICATIONS</h1>

[General Specifications]

Lead Wires Type

Model	5 tiers	LS7-502(D/S)WH-RYGBC
	3 tiers	LS7-302(D/S)WH-RYGNN
UL Registered Model		LS7-02(D/S)WH
Rated Voltage		24V DC (Non-polar)
Operating Voltage Range		Rated Voltage $\pm 10\%$
Signal Wire Current (Rated Current Consumption)	Typ.	Per Unit Red: 20mA Amber: 30mA Green: 30mA Blue: 30mA White: 30mA
	Max.	Per Unit Red: 35mA Amber: 40mA Green: 40mA Blue: 40mA White: 40mA
Operating Ambient Temperature		-30°C to +60°C
Operating Ambient Humidity		Less than 90% (No condensation)
Mounting Location		Indoors
Mounting Direction		Upright
Protection Rating		IP65 (IEC 60529)
Environmental Condition		Install the signal light on a sturdy and level surface
Vibration Resistance		19.6m/s ²
Insulation Resistance		More than 1M Ω at 500VDC between the terminals and the chassis
Withstand Voltage		500VAC applied for 1min between terminals and chassis without breaking insulation
Luminous Intensity		Red: more than 490mcd Amber: more than 1140mcd Green: more than 940mcd Blue: more than 195mcd White: more than 1000mcd
Mass (Tolerance $\pm 10\%$)		0.28kg
Outer Dimensions		Refer to Outer Dimension Drawing
Conformity Standards		UL 508, CSA-C22.2 No. 14
		EMC Directive (EN 61000-6-4, EN 61000-6-2)
		RoHS Directive (EN IEC 63000)
Remarks		<ul style="list-style-type: none"> · Conforms to the CE requirements · UL Recognized Component (File No.E215660)

M12 Connector Type

Model	5 tiers	LS7-502(D/S)WC-RYGBC
	3 tiers	LS7-302(D/S)WC-RYGNN
UL Registered Model		LS7-02(D/S)WC
Rated Voltage		24V DC (Non-polar)
Operating Voltage Range		Rated Voltage $\pm 10\%$
Signal Wire Current (Rated Current Consumption)	Typ.	Per Unit Red: 20mA Amber: 30mA Green: 30mA Blue: 30mA White: 30mA
	Max.	Per Unit Red: 35mA Amber: 40mA Green: 40mA Blue: 40mA White: 40mA
Operating Ambient Temperature		-30°C to +60°C
Operating Ambient Humidity		Less than 90% (No condensation)
Mounting Location		Indoors
Mounting Direction		Upright
Protection Rating		IP65 (IEC 60529)
Environmental Condition		Install the signal light on a sturdy and level surface
Vibration Resistance		19.6m/s ²
Insulation Resistance		More than 1M Ω at 500VDC between the terminals and the chassis
Withstand Voltage		500VAC applied for 1min between terminals and chassis without breaking insulation
Luminous Intensity		Red: more than 490mcd Amber: more than 1140mcd Green: more than 940mcd Blue: more than 195mcd White: more than 1000mcd
Mass (Tolerance $\pm 10\%$)		0.26kg
Outer Dimensions		Refer to Outer Dimension Drawing
Conformity Standards		UL 508, CSA-C22.2 No. 14
		EMC Directive (EN 61000-6-4, EN 61000-6-2)
		RoHS Directive (EN IEC 63000)
Remarks		<ul style="list-style-type: none"> Conforms to the CE requirements UL Recognized Component (File No.E215660)

[Model Number Configuration]

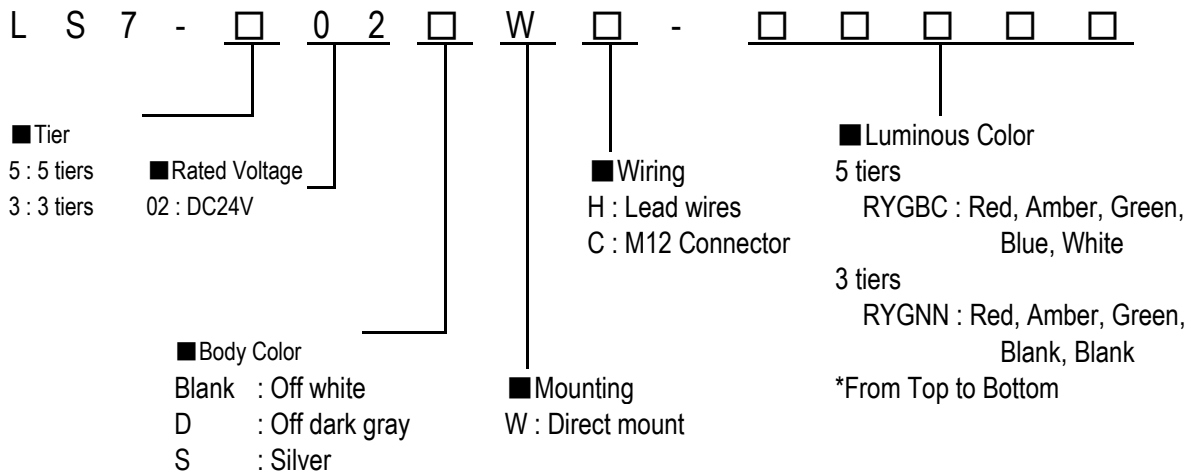

指定 外公差 General Tolerance	角度公差 ±[°]		寸法公差 ±[mm]					図番 Drawing No.		ページ Page	
	短辺 長さ Length of short side	~ ~ 100	6	30	120	300	1000	LS7-502-W18		3 / 4	
	精 f	1 0.5 0.3 0.1	中 m	0.1	0.3	0.5	0.7	1	改訂 Rev.	年月日 Date	改訂履歴 Revisions
	粗 v	3 1.5 1 0.5	粗 c	0.3	0.5	1	1.2	2	△		

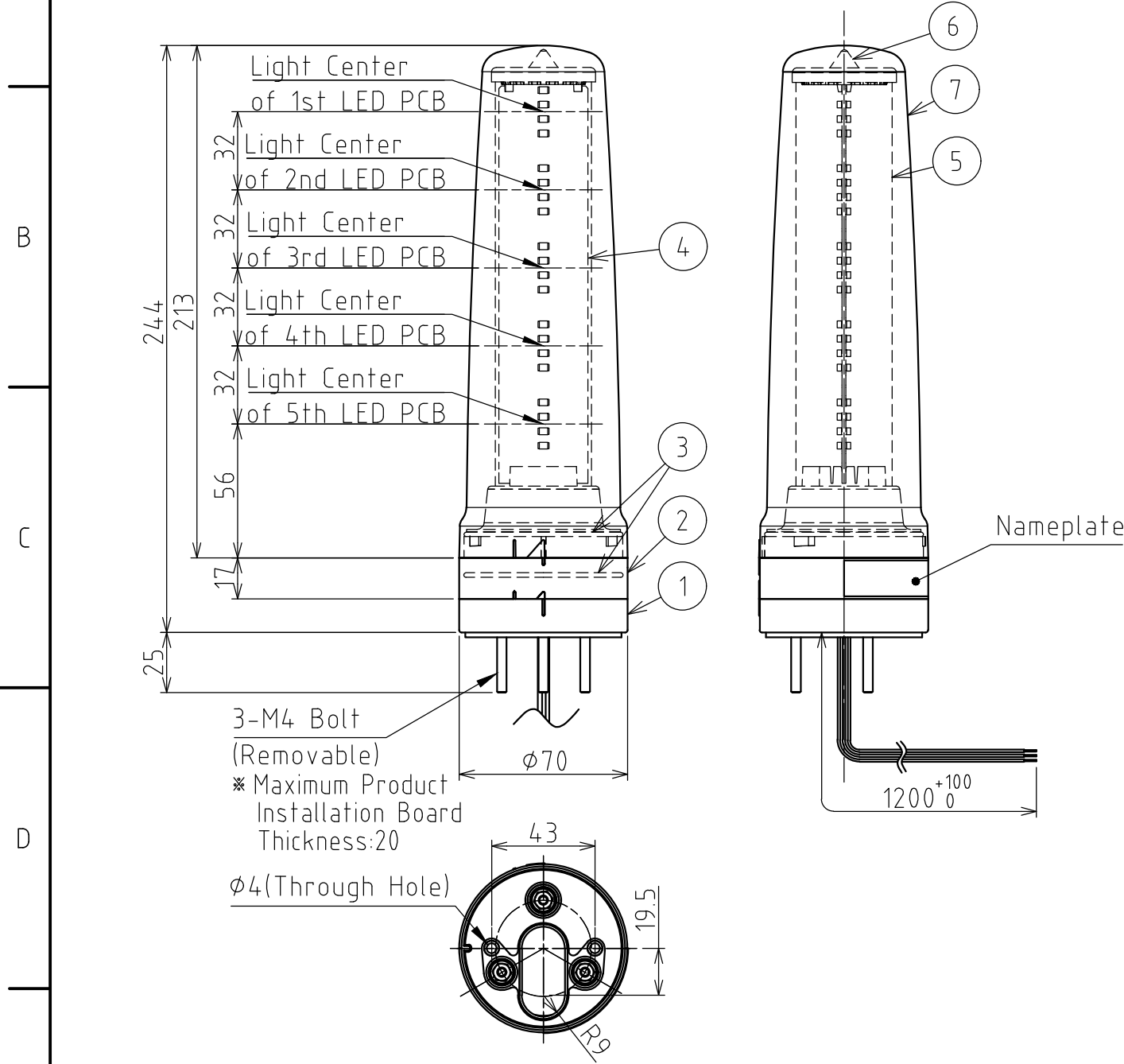

Wiring Example (Wire Type:UL1007/AWG22)

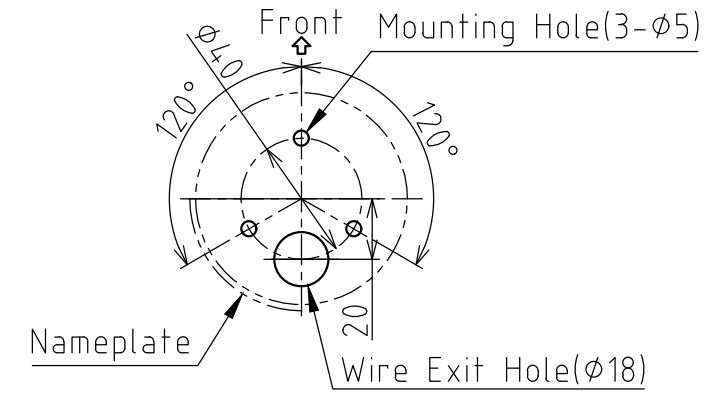
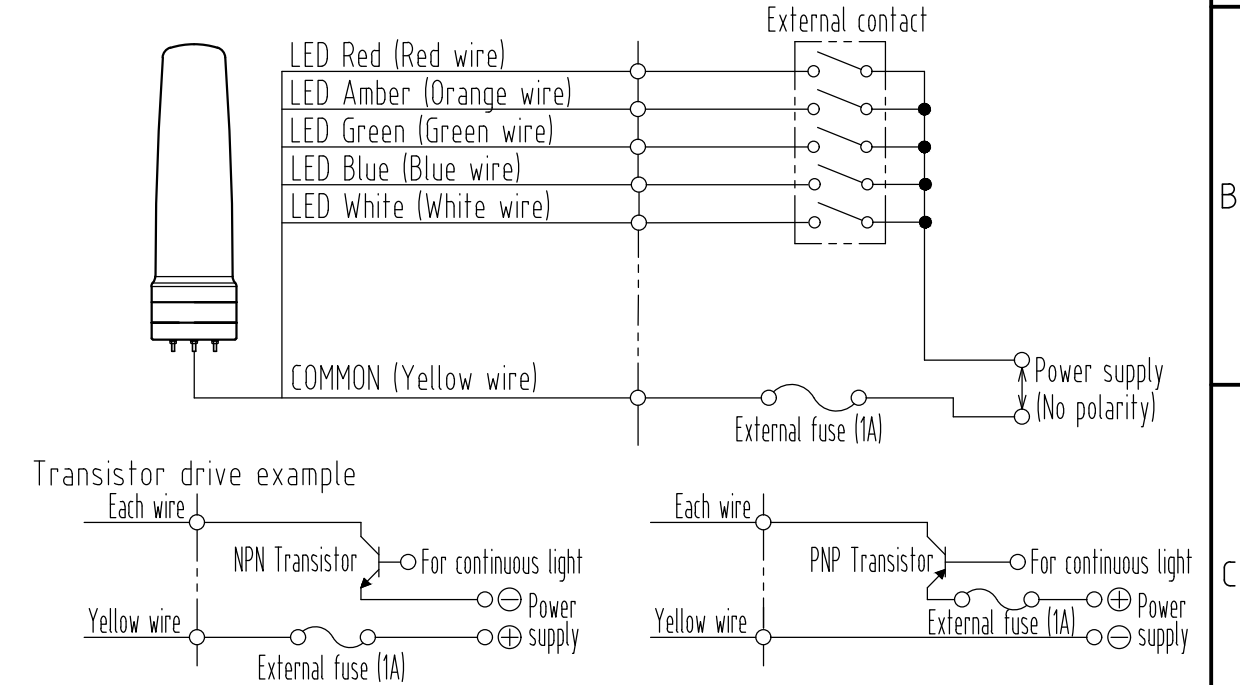

7	Outer Cover	1	PC
6	Cap	1	Si
5	Inner Lens	1	PC
4	LED PCB	1	
3	O-ring	2	Si
2	Base	1	ABS (S:Silver painting)
1	Mount	1	ABS (S:Silver painting)
総質量	質量	規格	注記

Note
 1. For water protection, refer to Fig1. for product upright positioning, do not make any additional holes beyond the three holes for mounting and one hole for wiring.
 2. When these are unused lead wires, be sure to separately insulate the ends of each unused wire.

機種 Model	LS7-502(D/S)WH	特注No. S.P.No.	-	図名 Name	Outer Dimensions Drawing
品目コード Part No.	-	尺度 Scale	-	三角法 3rd Angle P.	単位 Unit mm
		株式会社 PATLITE Corporation		Ver.2.2 A3	

指定公差 General tolerance		角度公差 Angular tolerance ±[°]		寸法公差 Dimensional tolerance ±[mm]					図番 Drawing No.		ページ Page		
短辺長さ Length of short side	~	~	100	6	30	120	300	1000	LS7-502-W18		4 / 4		
精 f	1	0.5	0.3	0.1	中 m	0.1	0.3	0.5	0.7	1	改訂 Rev.	年月日 Date	改訂履歴 Revisions
粗 v	3	1.5	1	0.5	粗 c	0.3	0.5	1	1.2	2			

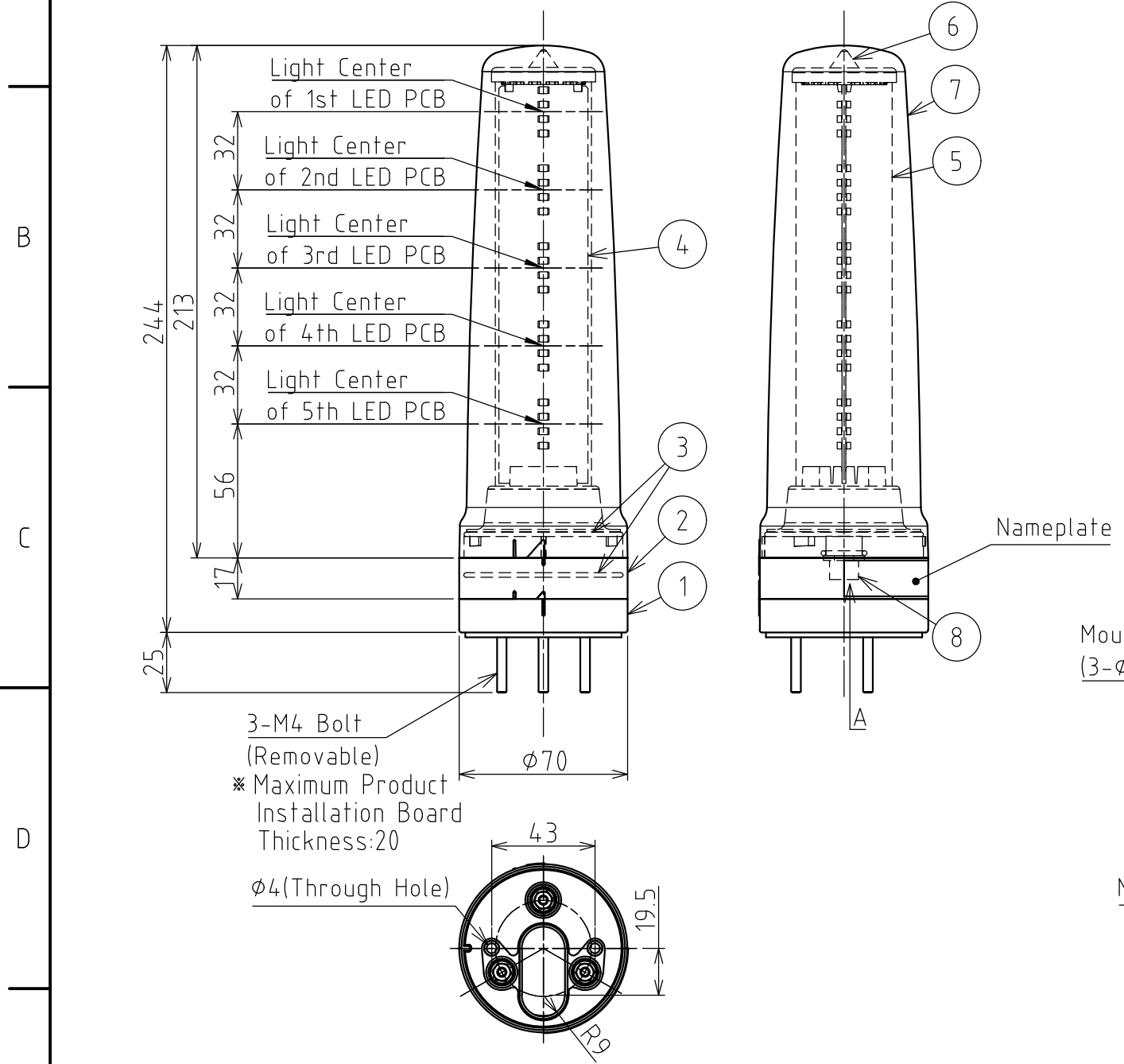

Wiring Example

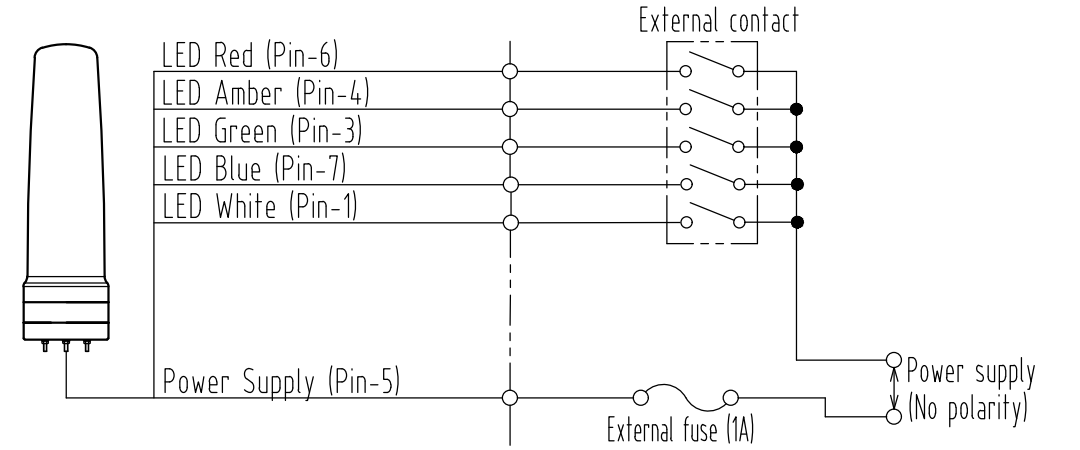

Transistor drive example

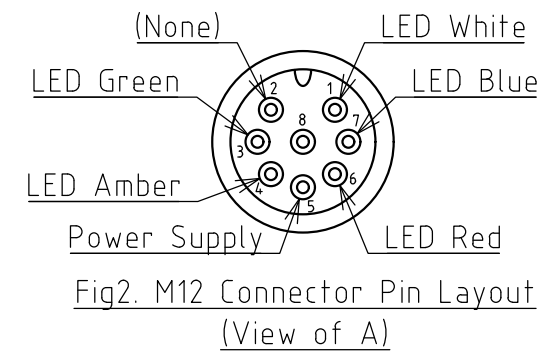
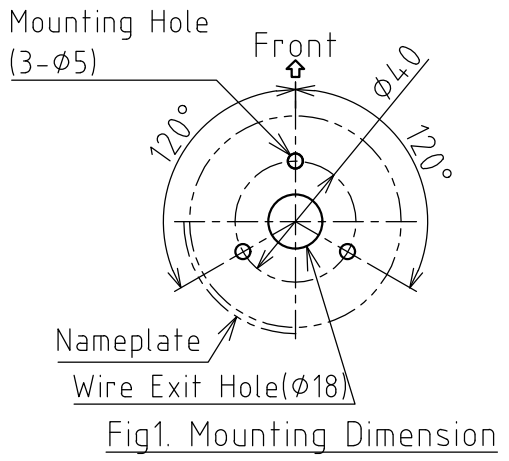
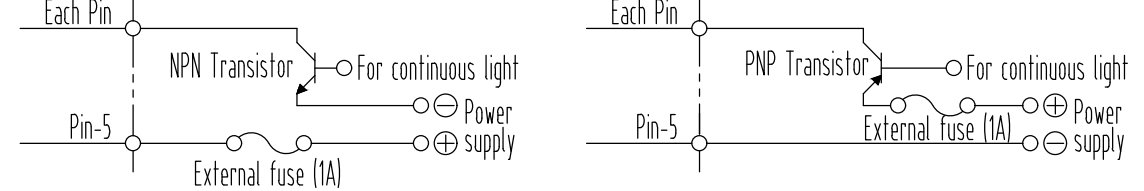

8	M12 Connector	1	XS2M-D824-4 (OMRON)
7	Outer Cover	1	PC
6	Cap	1	Si
5	Inner Lens	1	PC
4	LED PCB	1	
3	O-ring	2	Si
2	Base	1	ABS (S:Silver painting)
1	Mount	1	ABS (S:Silver painting)
番号 No.	部品名 Part Name	数量 Qty.	記事 Remarks

Note
 1. For water protection, refer to Fig1. for product upright positioning, do not make any additional holes beyond the three holes for mounting and one hole for wiring.
 2. The Cable used to Connector with the M12 Connector is an Optional Part.

機種 Model	LS7-□02(D/S)WC	特注No. S.P.No.	-	図名 Name	Outer Dimensions Drawing
品目コード Part No.	-	尺度 Scale	-	三角法 3rd Angle P.	単位 Unit mm
				株式会社 パトライト PATLITE Corporation	