

Vibrancy, Reliability, and Durability in a Compact Design



Luminous Color Type



Performance

- 4 flash patterns
- Connect up to 20 units to flash simultaneously or in an alternating pattern
- Brightness reduction mode

Durability

- High vibration resistance (90 m/s²)
- IP68 - Dust-proof and water-proof
- Life: 100,000 hours*

* Red, manufacturer-specified value



#1 Ranked Globally
in Signaling Devices

*1 2017 Global research study

Forklift Trucks

AGV

Control Panel

Plant Floor

Slim Design

Thin (13.5mm deep), compact design saves installation space.



Various Light Patterns

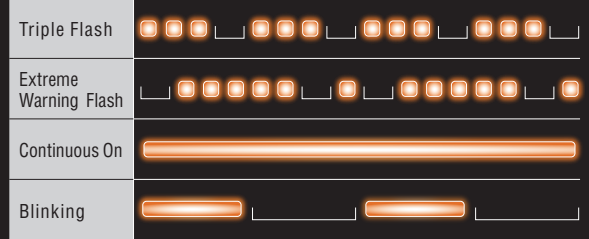

The following can be changed according to preset settings *

- Flash pattern
- Simultaneous or alternating flash (when multiple units are connected)

Video of Flash Patterns

How to Set Flash Patterns



*Factory default: Triple-flash, simultaneous flash

High Reliability

- Visible from great distances
- High vibration resistance, 90m/s²
- IP68 dust-proof, water-proof protection



Specification

Model	LPT-1M1-□ □:R/Y/G/B				LPT-2M1-□ □:R/Y/G/B			
Rated Voltage	12 - 24V DC							
Power Consumption (Max.)	R/Y 3.6W	G 7.2W	B 6.0W	R/Y 13.2W	G 15.6W	B 14.4W		
Mounting Location	Indoor/outdoor (In all directions)							
Protection Rating	IP68* (IEC 60529) / NEMA TYPE 4X, 13 *IPX8: under water at 1m for 1 hour, excluding the end of the cable.							
Luminous Color	Red, Amber, Green, Blue							
Daisy-chained	Maximum 20 units							
Mass	72g or less			130g or less				

Product Dimensions (mm)

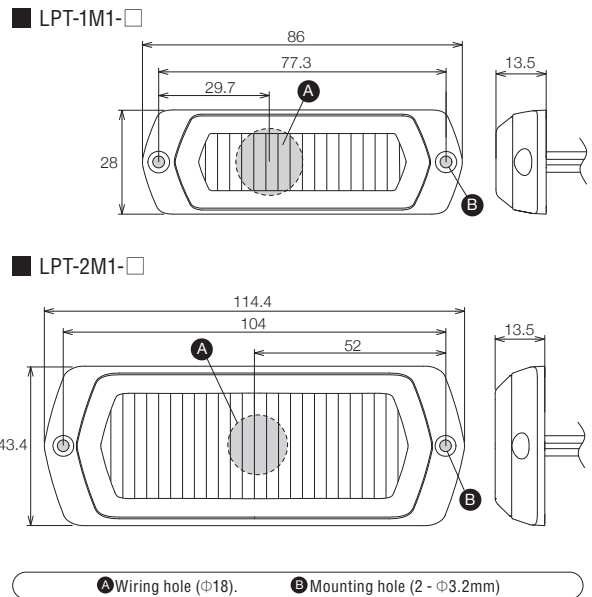

※ Please download the instruction manual or specification sheet from our website for more details.

PATLITE Corporation

4-1-3, Kyutaromachi, Chuo-ku, Osaka 541-0056 Japan
International Sales Division
TEL.+81-6-7711-8953 FAX.+81-6-7711-8961 E-mail: overseas@patlite.com.jp

PATLITE (U.S.A.) Corporation
20130 S. Western Ave. Torrance, CA 90501, U.S.A.
TEL.+1-310-328-3222 FAX.+1-310-328-2676 E-mail: sales@patlite.com

PATLITE (SINGAPORE) PTE LTD
No.2 Leng Kee Road, #05-01 Thye Hong Centre, Singapore 159086
TEL.+65-6226-1111 FAX.+65-6324-1411 E-mail: sales@patlite.com.sg

PATLITE (CHINA) Corporation
Room 1102-1103, No.55, Lane 777, Guangzhong Road (West), ZhabeiDistrict, Shanghai, China 200072
TEL.+86-21-6630-8969 FAX.+86-21-6630-8938 E-mail: sales@patlite.cn

PATLITE Europe GmbH
Am Soeldnermoos 8, D-85399 Hallbergmoos, Germany
TEL.+49-811-9981-9770-0 FAX.+49-811-9981-9770-90 E-mail: info@patlite.eu
WEEE Reg. Nr. 67267160

PATLITE KOREA CO., LTD.
A-2603, Daesung D-POLIS, 606, Seobusaet-gil, Geumcheon-gu, Seoul, 08504, Korea
TEL.+82-2-523-6636 FAX.+82-2-861-9919 E-mail: sales@patlite.co.kr

PATLITE TAIWAN CO., LTD.
2F-1, No.215, Sec. 2, Chengde Rd., Datong Dist., Taipei City 103645, Taiwan (R.O.C.)
TEL.+886-2-2552-9611 FAX.+886-2-2552-9811 E-mail: info@patlite.tw

PATLITE (THAILAND) CO., LTD.
Olympia Thai Tower, 15th Floor 444 Ratchadapisek Road Samsenok, Huay Kwang Bangkok 10310, Thailand
TEL.+66-2-541-5431 FAX.+66-2-541-5429 E-mail: sales_150716@patlite.co.th

PATLITE MEXICO S.A. de C.V.
Plaza de La Paz No. 102, int. 712 Guanajuato Puerto Interior, Silao, Gto, C.P.36275, Mexico
TEL.+52-472-748-9124 E-mail: ventas@patlite.com.mx

www.patlite.com

●PATLITE, the PATLITE logo are either registered trademarks or trademarks of PATLITE Corporation in JAPAN and/or other countries.

CAUTION

To ensure correct use of these products, read the "Instruction Manual" prior to use. Failure to follow all safeguards can result in fire, electric shock, or other accidents. Specifications are subject to change without notice.

O-BJ04 | EN | 2010