

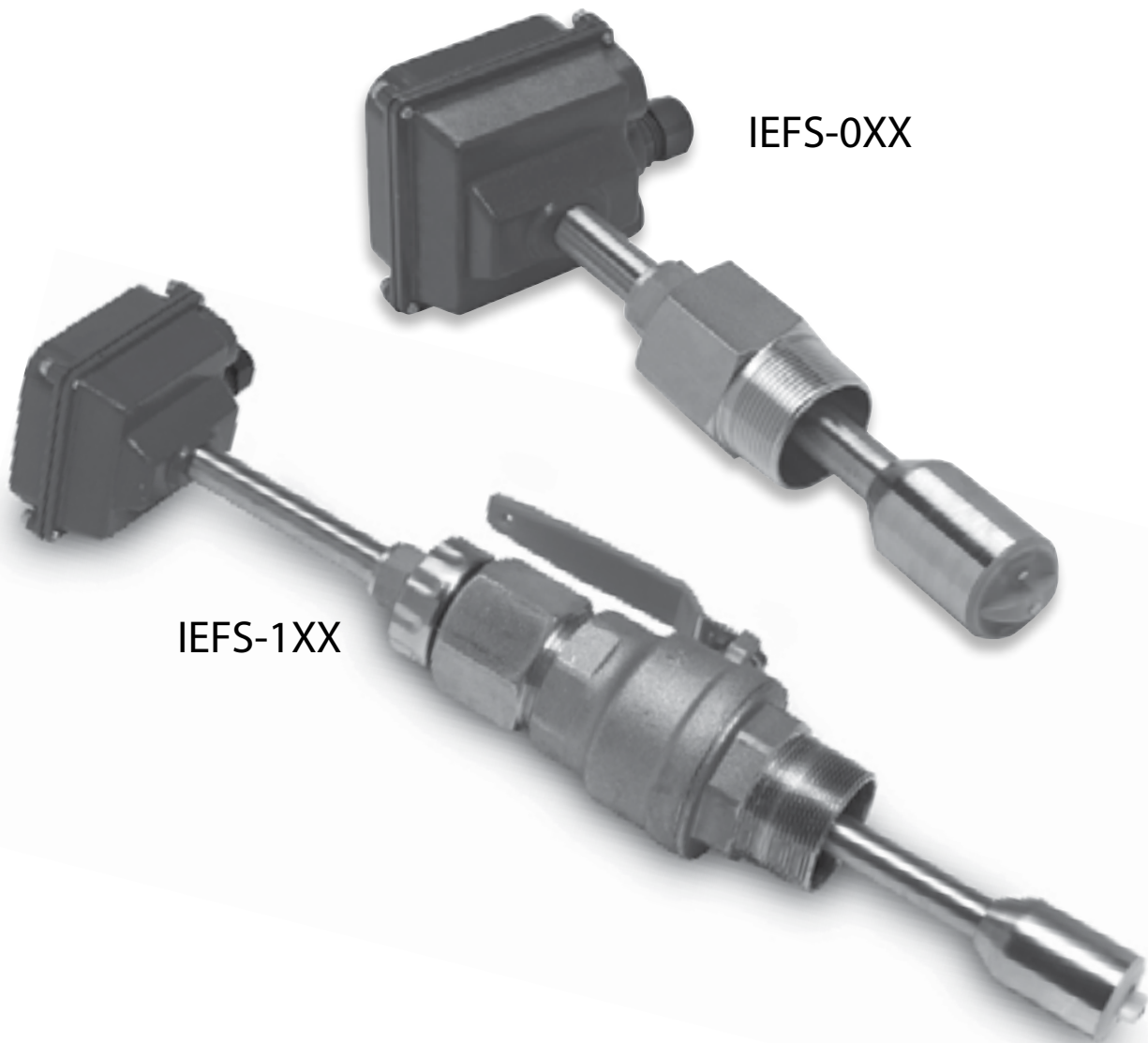

Series IEFS

INSERTION MAGNETIC FLOW METER INSTRUCTIONS



IEFS-0XX

IEFS-1XX

General Information
 General Information, Features, Specifications..... Page 1

Installation
 Piping, Distorted Flows, Immersion, Positioning the Meter Page 2
 Fitting Installation, Meter Installation..... Page 3
 Proper Depth Setting Page 4
 Dimension “C”, Pipe Wall Thickness..... Page 5
 Straight Pipe Recommendations Page 6
 Full Pipe Recommendations..... Page 7

Electrical Connections
 General Electrical Guidelines, Power, Forward (and Reverse) Flow Output,
 Grounding Guidelines, Grounding Diagram..... Page 8

Connections Diagrams
 Counter or PLC, Series BAT 4 to 20 mA Output..... Page 9

RTI Display and Proportional Feed, RTI & 4 to 20 mA Output, Dual RTI Displays Page 10

Operation & Maintenance
 Zero Adjustment, Minimum Flow, Presence of Flow Indication, Filtering,
 Electrode Coating..... Page 11

Calibration (“K-Factor”), Flow Rates in Gallons Per Minute Page 12

Troubleshooting
 Problems, Probable Causes and Things to Try..... Page 13

TABLES, DIAGRAMS & CHARTS

Features..... Page 1
 Distorted Flows, Positioning the Meter..... Page 2
 Meter Installation, Sensor Removal..... Page 3
 Proper Depth Setting Page 4
 Dimension “C”, Pipe Wall Thickness..... Page 5
 Straight Pipe Recommendations Page 6
 Full Pipe Recommendations..... Page 7
 Grounding Diagram..... Page 8
 Connection Diagrams: Counter or PLC, Series BAT 4 to 20 mA Output Page 9
 Connection Diagrams: Series RTI Display and Proportional Feed, RTI & 4-20 mA Output,
 Dual Series RTI Displays..... Page 10
 Zero Adjustment, Flow Rates in Gallons Per Minute..... Page 11
 IEFS K-factors (in Pulses/Gallon) for various pipe sizes Page 12
 Troubleshooting Problems, Probable Causes and Things to Try Page 13

GENERAL INFORMATION, FEATURES and SPECIFICATIONS

The complete lack of moving parts in the Series IEFS insertion flow sensor is the source of its reliability. Brass and stainless steel models withstand a variety of temperature, pressure, and chemical conditions. The IEFS Series has no rotor to stop turning in dirty water and there are no bearings to wear out. A rapidly reversing magnetic field is produced in the lower housing. As the fluid moves through this field, a voltage is generated that is measured and translated into a frequency signal proportional to flow rate. This square wave signal can be sent directly to a PLC or other control, or can be converted using any of the Dwyer Instruments Inc. family of indicators and converters. A modular system of electronics can be attached directly to the flow

sensor or remotely mounted. The Dwyer Instruments Inc. Series RTI provides full indication of rate and total, plus 4 to 20 mA output and the Series BAT provides blind 4 to 20 mA output. The adapter fitting of the sensor is standard male NPT, and can be directly threaded into ordinary saddles or threaded weld fittings. The IEFS-1 includes an isolation valve, allowing hot-tap installation, or installation and removal under pressure; a bronze ball valve is standard, with a 316 stainless steel valve option if needed.

Reverse flow output and immersibility are optional.

FEATURES

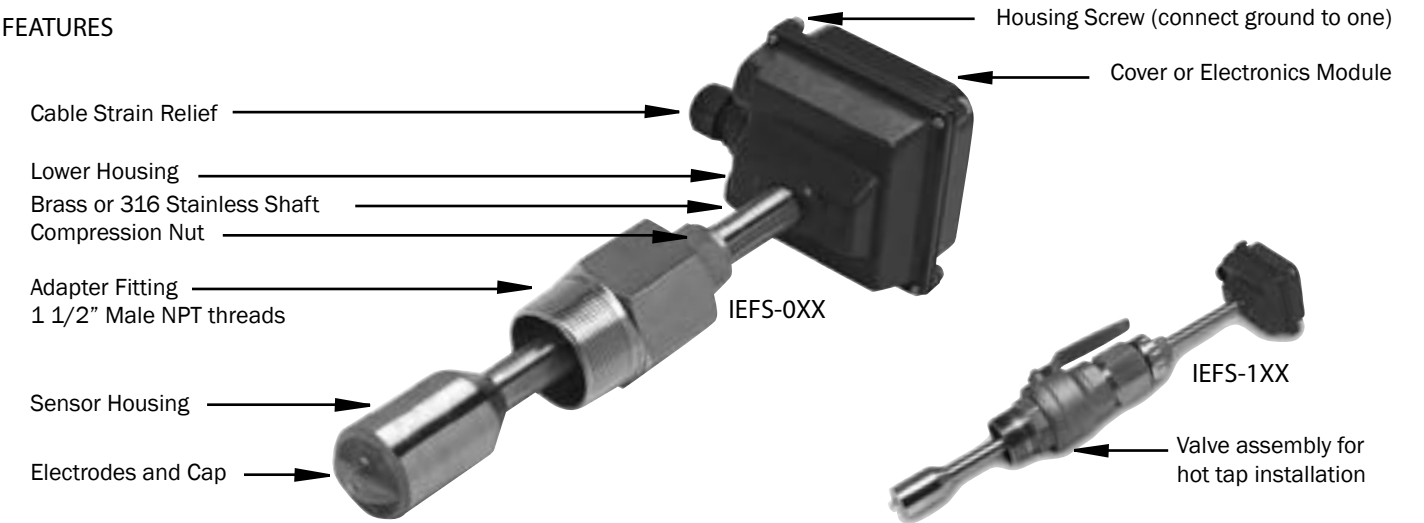

SPECIFICATIONS*

Pipe Sizes	3" to 48" (up to 60" when ordered with 12" extension option)	
Materials	Shaft/Fitting	316 SS or Brass
	Electrodes	Hastelloy®
	Electrode Cap	PVDF
	Housing	Cast powder-coated aluminum
	Valve Assembly (IEFS-1 Only)	Bronze (stainless optional) with bronze ball valve
	O-Ring (IEFS-1 Only)	EPDM
Power	Full Power	12 to 25 VDC, 250 mA
	Low Power	12 to 25 VDC, 40 mA average with 250 mA peaks
Flow Range	0.28 to 20 ft/sec (0.08 - 6.09 m/sec)	
Fitting Size	IEFS-0XX	IEFS-1XX
	1-1/2" Male NPT	2" Male NPT
Temperature	Ambient	0 to 160 °F (-17 to 72 °C)
	Fluid	32 to 200 °F (0 to 93 °C)
Pressure	200 psi (13.8 bar)	
Minimum Conductivity	20 microSiemens/cm	
Calibration Accuracy	+/- 1% of full-scale	
Output	Square wave pulse, opto isolated, 550 Hz @ 20 ft/sec 6 mA max, 30 Vdc forward flow standard; reverse flow optional	
Empty Pipe Detection	Software, defaults to zero flow	

*Specifications subject to change
 Hastelloy® is a trademark of Hanes International, Inc.

Piping. For best results, the IEFS sensor should be installed with at least ten diameters of straight pipe upstream and five downstream. Certain extreme situations such as partially-opened valves are particularly difficult and may require more straight diameters upstream (see page 6 for straight pipe recommendations).

DISTORTED FLOWS

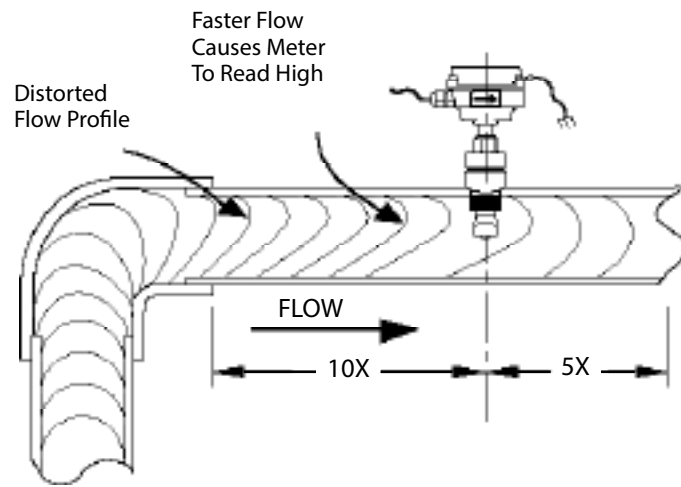

Immersion. The IEFS Series sensors are not designed for underwater operation. Even occasional immersion can cause damage. If occasional immersion is possible, such as when a vault floods, then the -IMM option, (immersion) is recommended.

Chemical Injection or Fertigation. When any magmeter, by any manufacturer, is used in a chemical injection application (including fertigation), the chemical line must be placed downstream of the magmeter OR far enough upstream for complete mixing to occur before the fluid reaches the meter. When unmixed chemical or fertilizer alternates with water passing through the meter, the rapid changes in conductivity may cause sudden spikes and drops in the meter's reading, resulting in inaccurate measurement. The magmeter will restabilize, however, with a steady flow of fluid of uniform conductivity.

Caution: In chemical injection or fertigation applications, install chemical line downstream of magmeter, or far enough upstream to allow complete mixing of fluids before the meter.

POSITIONING THE METER

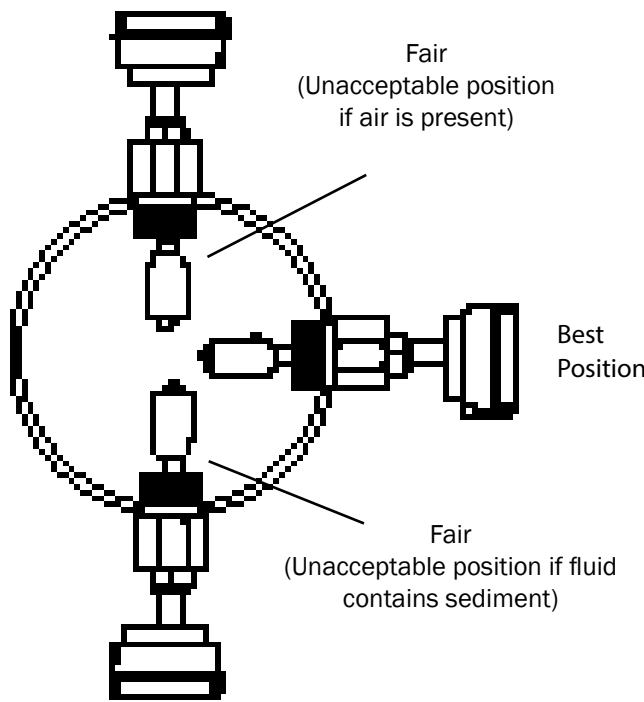

Vertical flow in upward direction is the preferred installation orientation, since it improves low-flow performance and avoids problems with trapped air and sediment. Bottom, top, and vertical pipe installations are all acceptable if required by the piping layout.

Caution: These flow sensors are not recommended for installation downstream of a boiler feedwater pump where installation fault may expose the flow sensor to boiler pressure and temperature. Maximum recommended temperature is 200 °F.

IEFS-0XX INSTALLATION

Fitting Installation. IEFS-0XX sensors come with a 1-1/2" male NPT pipe thread adapter fitting. Any fitting that provides the matching NPT female thread may be used. Installation procedure compensates for fitting height differences. Cut a minimum 1-3/4" hole in the pipe. If possible, measure the wall thickness and write it down for use in depth setting. Then install the threaded fitting (saddle, weldolet, etc.) on the pipe.

Meter Installation. Loosen the compression nut so that the adapter slides freely. Pull the meter fully upward and finger-tighten the compression nut. Using a thread sealant, install the adapter in the pipe fitting. Do not overtighten. Loosen the compression nut, and lower the meter to the appropriate depth setting (see diagram and instructions that follow). Be sure flow is in the direction of the arrow on the housing. Tighten compression nut fully.

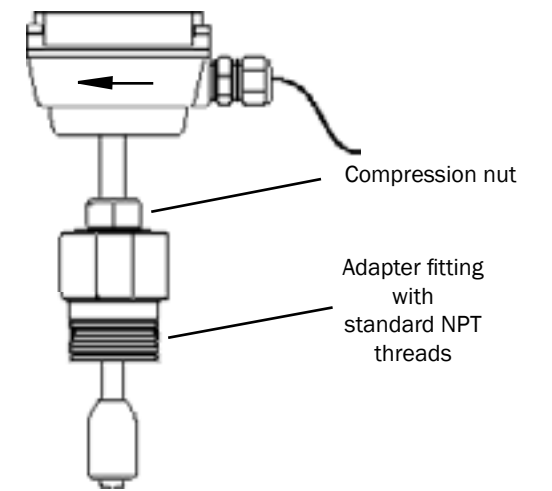

IEFS-1 INSTALLATION

'Hot-tap' IEFS-1XX meters are designed so they can be installed and serviced without depressurizing the pipe.

Fitting Installation. The IEFS-1XX sensors have a 2" NPT thread for compatibility with the 2" isolation valve. Any fitting that provides matching NPT female thread may be used. The installation procedure compensates for differences in fitting height.

If initial installation is performed on an unpressurized pipe, cut a minimum 1-3/4" hole in the pipe. If possible, measure the wall thickness and write it down for use in depth setting. Then install the threaded fitting (saddle, weldolet, etc.) on the pipe.

If it is necessary to do the initial installation under pressure, any standard hot tap drilling machine with 2" NPT adapter, such as a Transmate or a Mueller, can be used. Ordinarily, it is not necessary to use an installation tool, due to the small diameter tube the meter can be installed by hand in exception for applications with higher pipe pressures.

Meter Installation. Remove the sensor unit from the valve assembly. Using a thread sealant, install the valve assembly on the pipe fitting. If the initial installation is a pressure ("hot-tap"), remove the 1-1/2" x 2" adapter bushing at the back of the valve. Thread the tapping machine on, open the valve, and tap using a minimum of 1-3/4" or maximum 1-7/8" cutter. After retracting the machine and closing the valve, reinstall the flow sensor. When the sensor is secure, open the valve and adjust depth setting (see diagram and instructions that follow). Be sure flow is in the direction of the arrow on the housing. Tighten locking collar and compression nut fully.

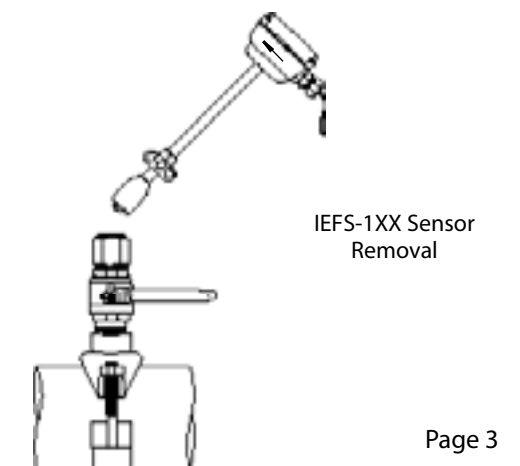
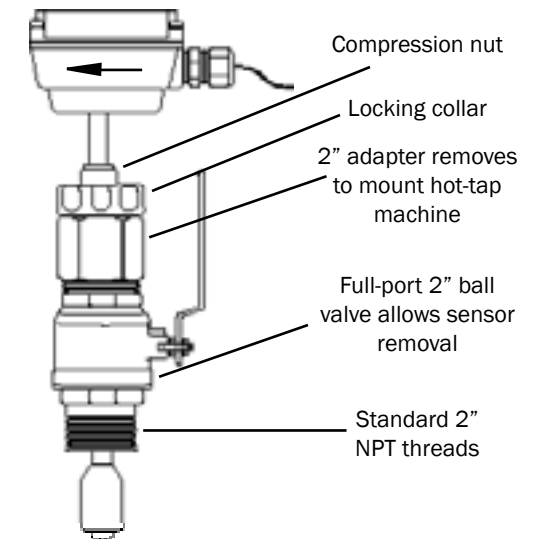

PROPER DEPTH SETTING

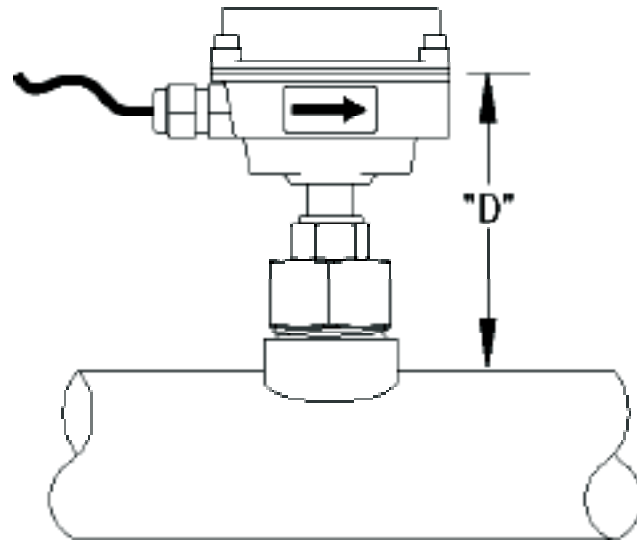

Depth Setting. It is important for accuracy that the sensor be inserted to the correct depth into the pipe.

1. In Table 1, find Dimension C for your sensor model and pipe size. Subtract wall thickness of your pipe (Table 2) to find Dimension D.
2. Measuring from the outside of the pipe to the joint in the housing, as shown in the diagram, adjust the sensor to Dimension D and hand-tighten compression nut.
3. Align the conduit housing with the centerline of the pipe, as shown. Be sure the arrow on the housing points in the direction of flow.



Caution! Never attempt to remove a flow sensor when there is pressure in the pipe unless it is specifically designed for hot tap installation and removal. Loosen the compression nut slowly to release any trapped pressure. If fluid sprays out when removing the sensor, stop turning and depressurize the pipe. Failure to do so could result in the sensor being thrown from the pipe, resulting in damage or serious injury.

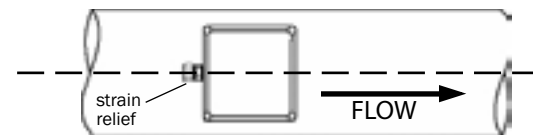

4. Check Dimension D one more time.
5. Tighten the compression nut fully.

TABLE 1: DIMENSION "C"

	NOMINAL PIPE SIZE												
	3"	4"	6"	8"	10"	12"	14"	16"	18"	20"	24"	30"	36"
IEFS-0SX	10.04	9.93	9.69	9.46	9.22	8.99	8.75	8.52	8.28	8.05	7.58	6.87	6.17
IEFS-0LX	15.04	14.93	14.69	14.46	14.22	13.99	13.75	13.52	13.28	13.05	12.58	11.87	11.17
IEFS-1SX	17.04	16.93	16.69	16.46	16.22	15.99	15.75	15.52	15.28	15.05	14.58	13.87	13.17
IEFS-1LX	21.04	20.93	20.69	20.46	20.22	19.99	19.75	19.52	19.28	19.05	18.58	17.87	17.17

TABLE 2: PIPE WALL THICKNESS

	NOMINAL PIPE SIZE												
	3"	4"	6"	8"	10"	12"	14"	16"	18"	20"	24"	30"	36"
PVC/Steel Sch. 40	0.216	0.237	0.280	0.322	0.365	0.406	0.438	0.500	0.562	0.593	0.687		
PVC/Steel Sch. 80	0.300	0.337	0.432	0.500	0.593	0.687	0.750	0.843	0.937	1.031	1.218		
Stainless Steel (10S)	0.120	0.120	0.134	0.148	0.165	0.180	0.188	0.188	0.188	0.218	0.250	0.312	0.312
Stainless Steel (40S)	0.216	0.237	0.280	0.322	0.365	0.375	0.375	0.375	0.375	0.375	0.375	0.375	0.375
Copper Tubing (Type L)	0.090	0.110	0.140	0.200	0.250	0.280							
Copper Tubing (Type K)	0.109	0.134	0.192	0.271	0.338	0.405							
Brass Pipe	0.219	0.250	0.250	0.312	0.365	0.375							
Duct. Iron (Class 52)	0.280	0.290	0.310	0.330	0.350	0.370	0.390	0.400	0.410	0.420	0.440	0.470	0.530

STRAIGHT PIPE RECOMMENDATIONS

(X = diameter)

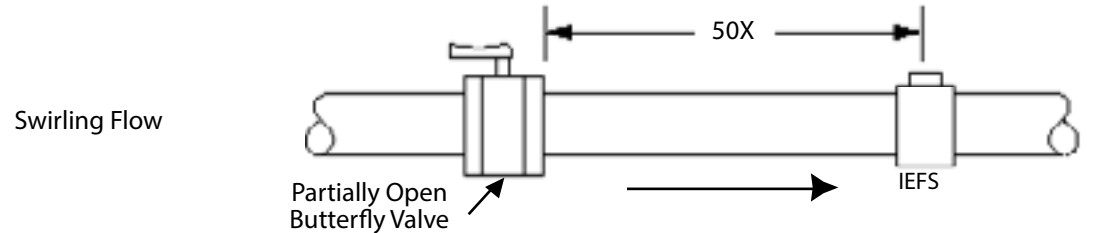
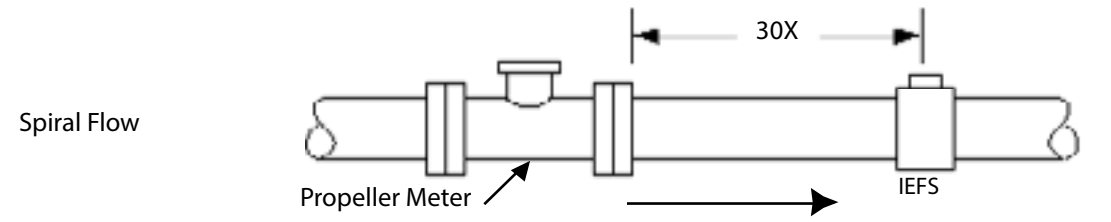
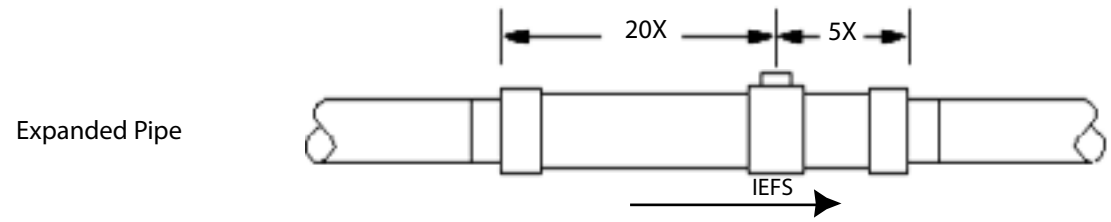
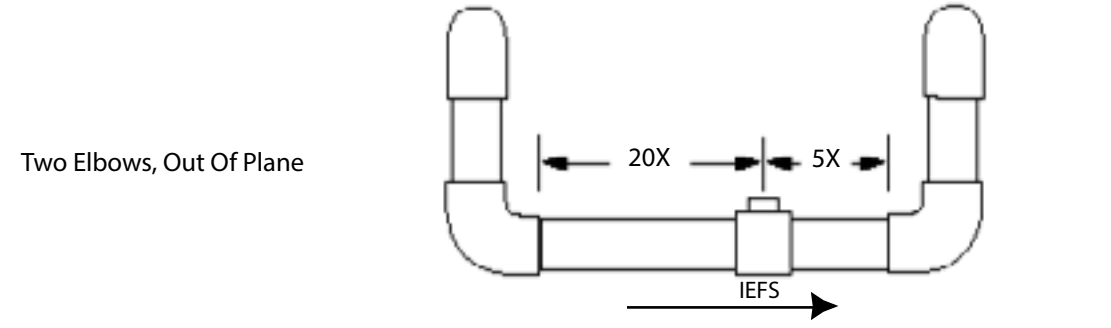
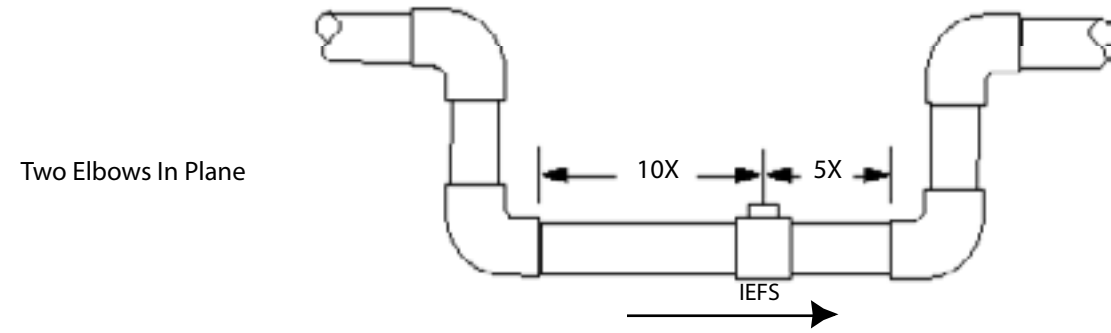
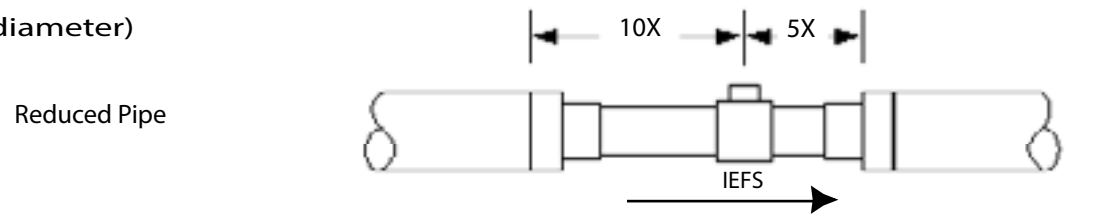

FULL PIPE RECOMMENDATIONS

Possible Problem

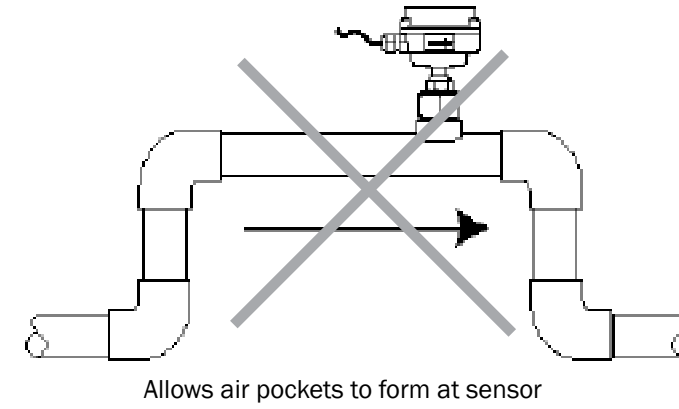

Better Installation

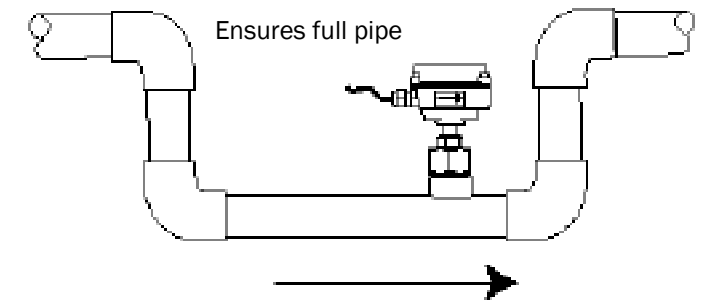

Possible Problem

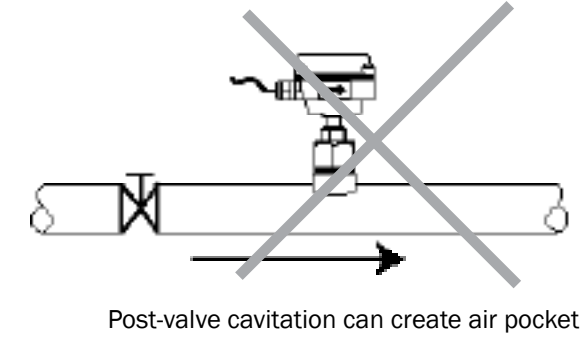

Better Installation

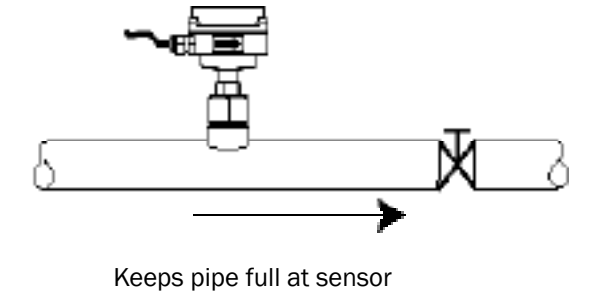

Possible Problem

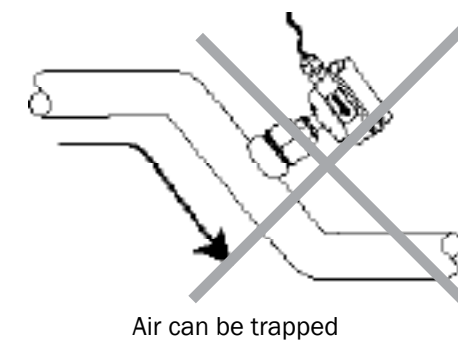

Better Installation

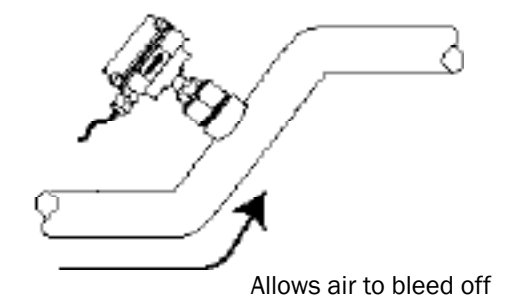

Caution: These flow sensors are not recommended for installation downstream of a boiler feedwater pump where installation fault may expose the flow sensor to boiler pressure and temperature. Maximum recommended temperature is 200°F.

General Electrical Guidelines:

- Whenever possible, avoid running control cables in the same conduit with or bundled with AC power.
- Using shielded cable, be sure to connect shield to ground at power supply end of the cable. Do not connect other end of shield.
- Avoid routing flow sensor cables in close proximity to a variable frequency drive.
- Recommended power and output wiring is shielded twisted pair 18 to 22 AWG control cable.
- Recommended voltage is 12 to 24 VDC. Note that unregulated power supplies can vary from nameplate voltage by a considerable amount, especially with AC line voltage fluctuation. Therefore 24V power supplies must be regulated.

See the Connections diagrams on the following pages for the appropriate terminals.

Power: A 12 to 24 Vdc power supply capable of at least 250 mA current output is needed.

Output: The standard output is pulses with flow in the forward direction (Reverse flow output is optional (-RFO)). Electrically it is an open collector opto isolated switch. The output is not internally powered.

Note: This output is limited to 6 mA at 30 Vdc maximum.

Grounding Guidelines:

For best results, use a good quality earth ground, such as metallic water piping or a driven ground, to ensure a good connection to earth ground and good noise suppression.

For Metallic Pipe: For optimum connection, clamp wire to the piping a short distance to one side of the flow sensor using an electrical grounding clamp. Connect the wire to the earth ground and to one of the housing screws, as shown in "Grounding Diagram" below.

For Non-Metallic Pipe: Connect a wire from the housing screws to a good earth ground, such as metallic water piping or a rod driven into the ground.

Series IEFS & EFS2 meters are usually unaffected by moderate levels of electrical noise. In some applications performance may be improved by taking the following steps:

- Use shielded twisted pair cable (Belden 8723 or equivalent above ground or Alpha 35482 or equivalent burial).
- Clamp a ferrite bead (Steward 28A2029-OAO or equivalent) on meter signal/power wire within 3/4" of the meter strain relief (tape or tie wrap in place if necessary). See diagram below.
- IMPORTANT - Connect the cable shield ground wire to ground, ONLY at power supply end of cable.

GROUNDING DIAGRAM

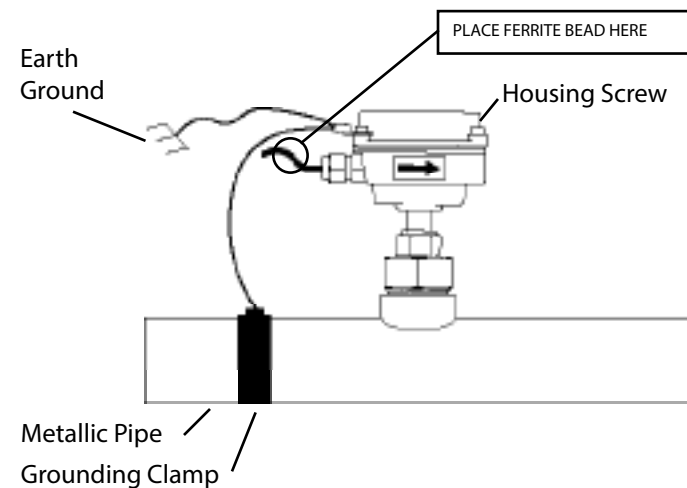

COUNTER OR PLC

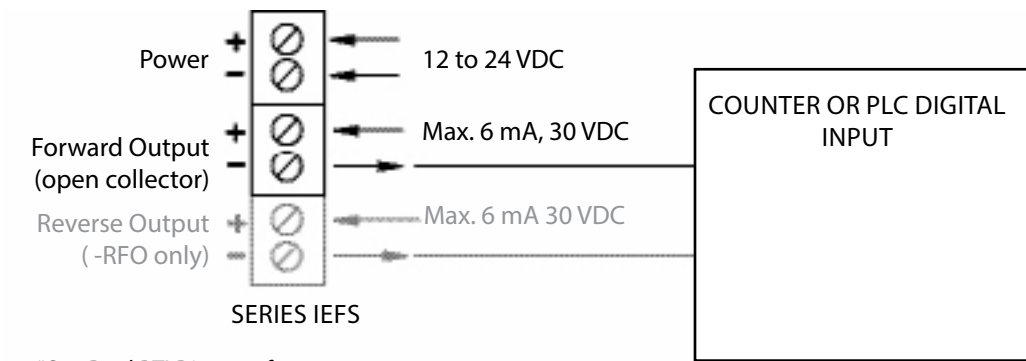

*See Dual RTI Diagram for an example of bidirectional connections.

BAT 4 to 20 mA OUTPUT

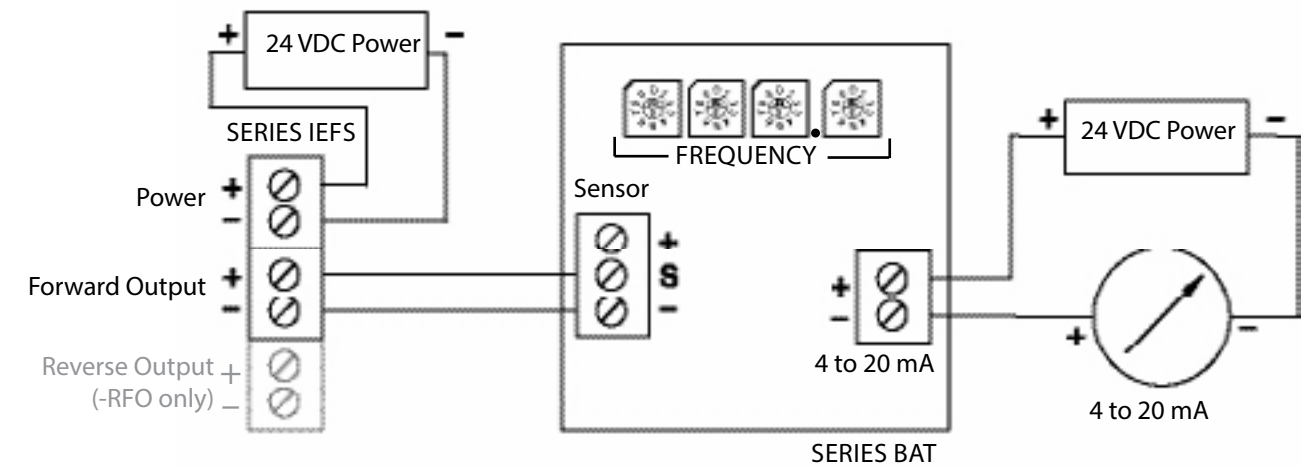

*See Dual RTI Diagram for an example of bidirectional connections.

SERIES RTI DISPLAY AND PROPORTIONAL FEED

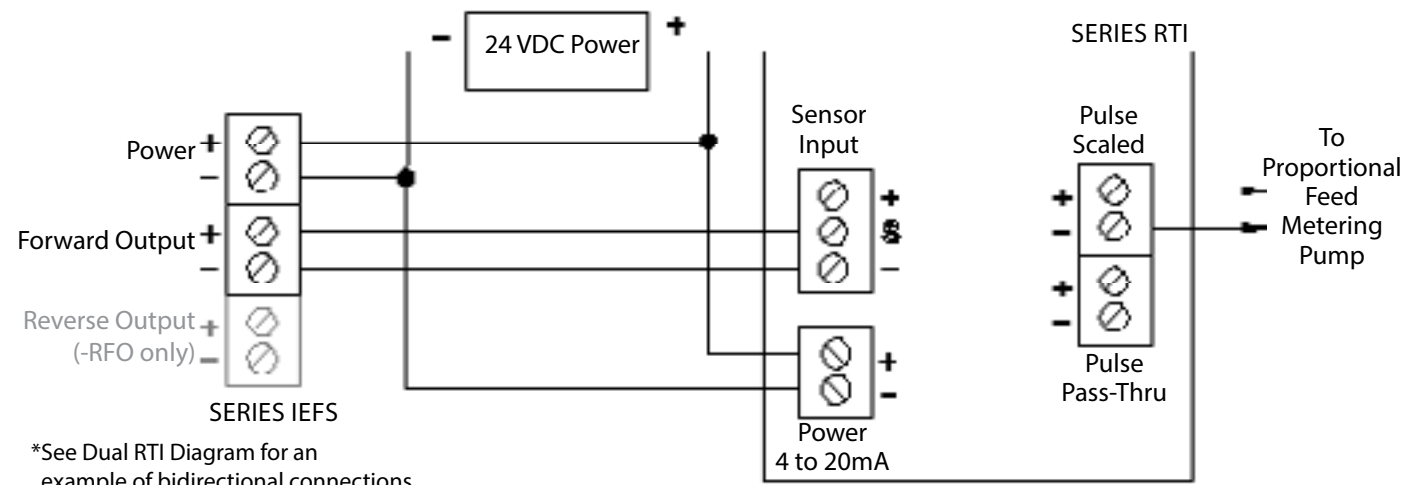

*See Dual RTI Diagram for an example of bidirectional connections.

SERIES RTI DISPLAY AND 4 to 20 mA OUTPUT

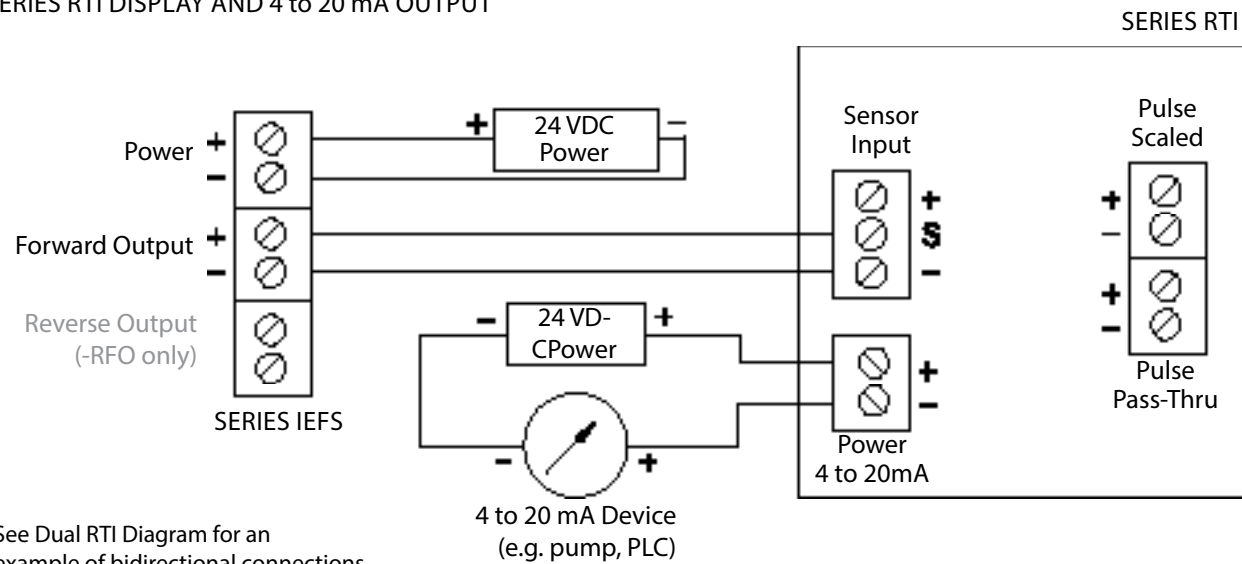

*See Dual RTI Diagram for an example of bidirectional connections.

DUAL SERIES RTI DISPLAYS
(Example of Bidirectional Connection)

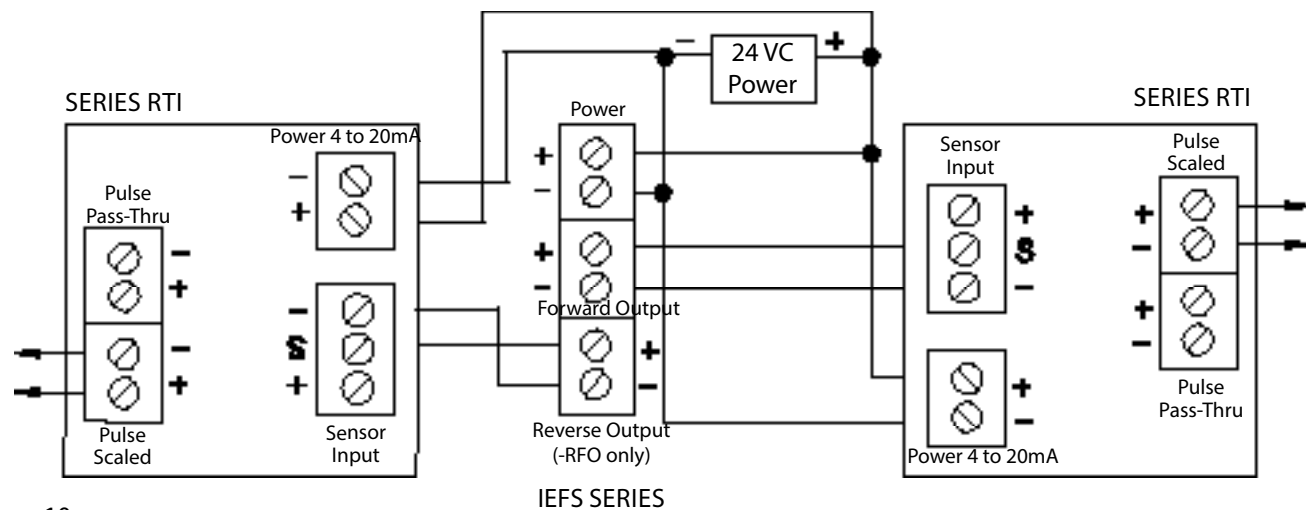

Zero Adjustment. When the Series IEFS meter is powered up and there is no flow, there should be no output pulses (or, if connected to the RTI, flow rate should read "0"). If there are pulses, it may be necessary to adjust the flow meter under no-flow conditions after it has been installed. This should only be done if the indicated flow is low, near the lower cutoff.

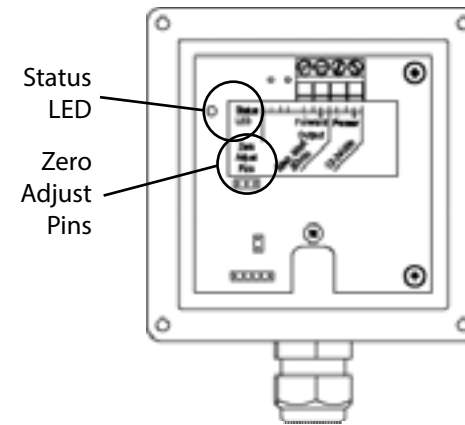

To perform the adjustment, after determining that there is a full pipe with no flow, short between the two pins marked "Zero Adjust". A red LED light will come on for approximately 50 seconds and then go out. The zero adjustment is completed.

Minimum Flow. As with any other flow sensor, there is a rate below which the IEFS Series sensor cannot read. Check the table below for the minimum flow rate detectable by the sensor for a given pipe size.

Presence of Flow Indication. To assist in troubleshooting, the "Status LED" has two blinking modes in normal operation. When there is no flow detectable by the meter (below minimum threshold), the LED blinks every 8.0 seconds. When there is detectable flow, the same indicator blinks every 3.0 seconds (Pulses are being output when indicator is blinking every 3 seconds).

Filtering. The software of the IEFS Series filters out electrical noise and averages sudden variations in the flow to smooth the output. It takes a matter of seconds for the flow sensor to get up to full output when it is powered up or when flow begins.

Electrode Coating. Grease or other adhering, non-conductive materials can stop flow detection if the electrodes become heavily coated. To clean the electrodes, remove the sensor from the pipe and gently scrub the electrodes (three silver bumps) on the reading face of the flow sensor. A mild soap (dishwashing liquid for example) can be used to aid the cleaning process.

FLOW RATES (IN GALLONS PER MINUTE)

Feet Per Second	NOMINAL PIPE SIZE													
	3"	4"	6"	8"	10"	12"	14"	16"	18"	20"	24"	30"	36"	48"
Min 0.28	6	11	25	44	69	99	134	175	222	274	395	617	888	1580
Max 20.0	440	783	1,762	3,133	4,895	7,050	9,596	12,533	15,863	19,584	28,200	44,064	63,452	112,804

Calibration ("K-Factor"). In order to properly process pulses from the flow sensor, a number must be entered into the control to which the sensor is connected. This number, called the K-factor, is the number of pulses the sensor puts out per unit of fluid passing through the pipe. It is normally provided for Dwyer Instruments Inc. sensors in pulses per gallon, and

is given on the chart "K-factors for Various Pipe Sizes" below. These numbers are based on extensive testing, which has shown close agreement between different IEFS sensors in the same installation. Typically, most K-factor errors can be attributed to installation variables, such as depth setting and fitting configuration.

IEFS K-factors (in Pulses/Gallon) for various pipe sizes

	Nominal Pipe Size												
	3"	4"	6"	8"	10"	12"	14"	16"	18"	20"	24"	30"	36"
PVC/Steel Sch. 40	70.397	40.985	18.130	10.497	6.674	4.709	3.900	2.989	2.364	1.904	1.319		
PVC/Steel Sch. 40	78.748	45.360	20.084	11.495	7.322	5.184	4.297	3.281	2.588	2.094	1.451		
Stainless Steel (10S)	62.385	36.626	16.510	9.642	6.173	4.373	3.620	2.756	2.169	1.762	1.223	0.784	0.576
Stainless Steel (40S)	70.397	40.985	18.130	10.497	6.674	4.661	3.827	2.893	2.263	1.819	1.249	0.791	0.580
Copper Tubing (Type K)	76.371	43.552	19.513	11.201	7.230	5.016							
Copper Tubing (Type L)	78.371	44.638	20.223	11.622	7.500	5.239							
Brass Pipe	70.672	41.517	17.778	10.445	6.674	4.661							
Duct Iron (Class 52)	57.376	37.320	16.915	9.503	6.197	4.325	3.189	2.443	1.931	1.565	1.088	0.747	0.520

Problem	Probable Cause	Try...
No pulse output	Unit not grounded	Connect to earth ground
	Below minimum flow cutoff	Check the Presence of Flow LED (see p. 12)
	Flow reversed	Note flow direction arrow, reverse direction to meter
	Output connections reversed	Change output connections
	Pipe not full	Check plumbing
	Excessive electrical noise	Check for proper electrical wiring
	No power	Check for power across power input terminals
	Power reversed	Reverse connections
	Fluid conductivity <20 microSiemens/cm	Select another flow meter
Output pulses incorrect	Missing or incorrect ground wire	Check for proper ground
	Incorrect depth setting	Check depth setting from Dimension "C" table (page 4)
	Fluid conductivity <20 microSiemens/cm	Select another flow meter
	Empty pipe	Check for full pipe or install meter in the vertical position
	Not enough straight pipe	Check for air pockets or turbulence. Refer to installation, page 6
	Excessive electrical noise	Check for proper electrical wiring
Jumpy reading	Rapidly changing conductivity (in chemical injection or fertigation applications)	Install chemical injection line downstream of magmeter (or far enough upstream to allow complete mixing of fluids before meter)

WARRANTY/RETURN

Refer to "Terms and Conditions of Sale" in our catalog or on our website. Contact customer service to receive a Returns Goods Authorization number before shipping your product back for repair. Be sure to include a brief description of the problem plus any relevant application notes.

