

PS11 – Ultra-Long Life OEM Pressure Switches

- ▶ 0.75 to 15 psi (52 to 1034 mbar)
- ▶ Factory Set or Adjustable Set Points

For low pressure applications, the longevity of our PS11 Series is hard to beat. Their snap-action microswitch resets automatically and meets or exceeds industry standards. The brass housing offers chemical resistance at an affordable price.

Specifications

Switch*	5 Amp @ 24 VDC and 250 VAC 1.0 Amp resistive 0.5 Amp inductive @ 24 VDC (-G option)
Repeatability	See Table 1
Wetted Parts	
Diaphragm	Nitrile (optional Viton®, EPDM or Kapton®)
Fitting	Brass
Housing	Brass
O-Ring	Nitrile (optional Viton® or EPDM)
Ingress Protection**	DIN 43650A IP00; Terminals IP00; Flying Leads IP00
Proof Pressure	0 psia to 150 psi (-1 bar to 10.3 bar)
Burst Pressure	300 psi (20.7 bar)
Approvals	CE, UL Approved units available
Weight, Approximate	0.31 lbs. (0.14 kg)

* Gold contacts (option G) may be required for less than 12 VDC and 20 mA.
** Plastic housing is vented to atmosphere. Consult factory for non-vented version, IP-rated version.

Recommended Operating Temperature Limits

Diaphragm Material	Range
Nitrile	15°F to 250°F (-9°C to +121°C)
Viton®	0°F to 250°F (-18°C to +121°C)
EPDM	-20°F to +250°F (-29°C to +121°C)
Kapton®	-40°F to +250°F (-40°C to +121°C)

Note: Switches may function below the cold temperature limit but the set point and deadband will increase. Consult factory for details.



Dimensions

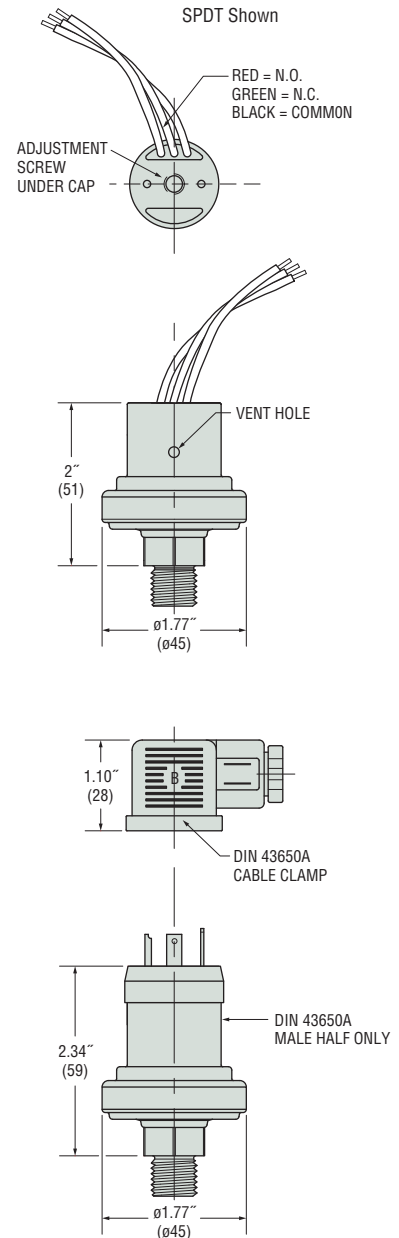

How To Order

Use the **Bold** characters from the chart below to construct a product code. Please reference Notes.

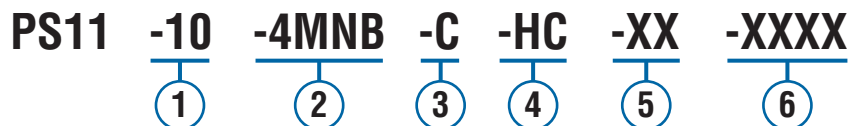

① Pressure Range Code

Insert Pressure Range Code from Table 1, below.

② Pressure Fitting¹

- 2MNB = 1/8" NPTM Brass
- 4MNB = 1/4" NPTM Brass
- 4MGB = 1/4" BSPM Brass (G type)
- 4MSB = 7/16"-20 SAE Male, Brass

③ Circuit

- A = SPST/N.O.
- B = SPST/N.C.
- C = SPDT

④ Electrical Termination²

- FLXX = Flying Leads³
- ELXX = 1/2" Male NPT Conduit w/Flying Leads³
- H = DIN 43650A Male Half Only
- HC = DIN 43650A 9mm Cable Clamp
- HN = DIN 43650A 1/2" NPT Female Conduit

⑤ Options

- V = Viton® Diaphragm
- E = EPDM Diaphragm
- K = Kapton® Diaphragm
- G = Gold Contacts
(for loads less than 12 mA @ 12 VDC)
- OF = Oil Free Cleaned
- WF = Weather Pack Connector, Female
- WM = Weather Pack Connector, Male
- DE = Deutsch Connector, Male, DT04 Series

⑥ Fixed Set Point (optional)

- A. Specify set point -**FS** (in PSI or mBAR, see example)⁴
- B. Set Point Actuation
- R** on Rising Pressure
- F** on Falling Pressure
- Example: -**FS200MBARF** for 200 mBAR Falling
- or -**FS3PSIR** for 3 PSI Rising

Notes:

1. Other fittings available. Consult factory.
2. DIN units are available with -**C** SPDT circuit only.
3. 18" is standard. Specify lead length in inches (max. 48"). e.g. -**FL18** or -**EL30**.
4. Set Point must be within Pressure Range selected in Step 1.

Table 1 — Pressure Range Codes

Pressure Range Code	Pressure Range	Accuracy*	Average Deadband**
10	0.75-4 psig (51-276 mbar)	±0.15 psi (10 mbar) +4% of setting	0.2 psi (14 mbar) +9% of setting
20	3.5-15 psig (241-1034 mbar)	±0.25 psi (17 mbar) +5% of setting	0.4 psig (26 mbar) +11% of setting

* Accuracy and set point of units may change due to the effects of temperature.

** In certain applications deadband can be tailored and controlled to customer specifications. Consult factory for details.