



SPHERA GROUP

ULTRA LOW FREEZER

ULF 120 W PRO 2 (White finishing)

- **Structure:** upright type, realized in sheet steel painted white colour (rust- and corrosion-proof) outside and stainless steel 18/10 AISI 304 inside
- **Insulation:** injected polyurethane a high density, with a thickness of 130 mm. CFC-free
- **Casters:** Nr 4 made in rubber and swivelling in order to make easy any moving required. The castors mounted in the front side are fitted up with brakes with foot lever control to block them once the freezer has been positioned
- **Door:** Nr 1, hinged, fully insulated, externally it is executed in the same material of the structure (sheet steel painted white colour) while internally it has non-conductive material. A perfect hermetic closing is assured through a double gasket system, one, magnetic mounted on the door itself and another one, silicone type, mounted on the structure of the freezer. The gaskets are even provided with a special heating system to prevent the freezing and thanks to the vacuum-release valve the door can be immediately re-opened a closing. In the right part of the door is mounted the effort-free locking mechanism which incorporate the safety key lock
- **Inner door:** Nr 1, hinged, realized in stainless steel 18/10 AISI 304 in the external side and non-conductive material in the internal one. The inner doors prevent air-cold loss at the external door opening and they are also provided with a locking mechanism with a lever
- **Internal equipment:** Nr 1 storage shelf realized stainless steel 18/10 AISI 304 that divides the storage chamber in 2 compartments with dimensions (W x D x H) 45 x 45 x 27 cm each. The shelf is mounted on brackets and they can be easily adjusted in height or removed without the use of any tool. Shelf dimensions (W x D) 45 x 45 cm
- **Control panel "PRO2":** door mounted eye-level for a high comfort of use, microprocessor operating, with user interface through a colour touch-panel display of 7". The controller supervises all the freezer functions through an interface, with icons and written messages, allowing a very intuitive interactivity between the appliance and the user, for an easy setting of all appliance functionalities according to needs and the control of the workings status. The control panel is battery operating in order to grant the functioning of the display and alarms even in case of power failure. The main functions panel are:
 - High resolution colour touch display of 7", showing the appliance working status (actual temperature, compressor functioning, alarm signalling, etc.) and allowing the surfing through the various controller menu for setting and checking purposes
 - Digital temperature displaying and adjusting with an accuracy of 0,1°C
 - Dual-level safety access, with PIN code protections, for both switching the freezer ON/OFF and to access to the control panel menu. Re-programmable PIN code for increased security from access to the unauthorized personnel
 - Back-up battery, with automatic recharging, granting till 48 hours autonomy for the control panel functioning in case of power failure. The charging status is continuously shown on the display for immediate checking
 - Visual and acoustic alarm signalling (with automatic resetting) for:
 - high and low temperature, with limits programmable from the user through a dedicated menu
 - door ajar, with delayed activation to allow the standard operations. Programmable alarm delay through a dedicated menu
 - power failure
 - battery discharged
 - condenser dirty
 - sensors failure

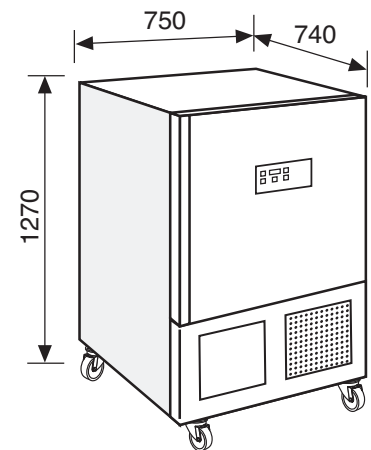

- Real-time temperature chart, with possibility to scroll to the previous data
- Written indications on the display selectable from 2 languages (Italian and English)
- NO/NC contact to remote the alarm signals
- Software upgrading facilities according to the release
- **Cooling unit:** bottom mounted, compounded by Nr 2 hermetic compressors (cascade) with a power of 0,5 HP each, Nr 1 finned condenser, air cooled through a fan and special electro-valves. The cooling unit compartment is adequately acoustically insulated to limit the noise level. Also, foamed into the insulation of all storage chamber walls, there are the evaporating pipes, in order to grant the maximum temperature stability and uniformity. All the mounted components are industrial grade to grant the maximum reliability
- **Refrigerant:** CFC-free
- **Refrigeration:** static, with evaporating pipes throughout all the chamber in order to grant maximum temperature stability and uniformity
- **Temperature range:** infinitely adjustable between -50°C / -86°C
- **Voltage (V/ph/Hz):** 220-230/1/50
- **Plug:** Schuko type
- **Noise level (dB(A)):** ≤ 52
- **Capacity (litres):** 120
- **Dimensions (W x D x H cm):** 76 x 74 x 127
- **Net weight (Kg):** 210
- **Packed dimensions (W x D x H cm):** 95 x 95 x 158 (1,43 m³)
- **Gross weight (Kg):** 230

ULTRA LOW FREEZER

ACCESSORIES AVAILABLE



Storage rack for boxes

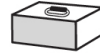

Box for storage rack

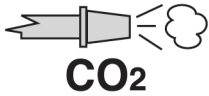

CO2 back-up system



Temperature chart recorder



Gloves



GSM/GPRS telephone dialer



230V / 60 Hz Different voltage



115V / 60 Hz Different voltage

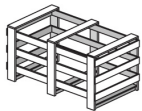

Wooden crate packing



ISO 9001:2015



EN ISO 13485:2016



VERS. 11.20

* The declared performances are referred at +26°C ambient temperature, relative humidity of 70% and without any internal thermal mass (empty cabinet).

* Should it be necessary or useful without undermining any model essential features, technical and stylistic characteristics are subject to be changed without manufacturer's previous notice.

SPHERA GROUP s.r.o.

info@sphera-group.cz

Tel: +420 226 886 248

Průmyslová 7 Business Park

102 00 Praha, Czech Republic



SPHERA GROUP