

Membrane Distillation pilot tests for different wastewaters

Separation of pharmaceutical residues and treatment of flue gas condensate with Xzero Membrane Distillation in Pilot Scale at Hammarby Sjöstadsvverk

*Uwe Fortkamp, Hugo Royen, Magnus Klingspor, Östen Ekengren
Andrew Martin, Daniel Minilu Woldemariam*

Author: Uwe Fortkamp, Hugo Royen, Magnus Klingspor, Jörgen Magnér, Östen Ekengren IVL
Andrew Martin, Daniel Minilu Woldemariam KTH

Funded by: Xzero & SIVL, Foundation for IVL Swedish Environmental Research Institute

Report number: B 2236

Edition: Only available as PDF for individual printing

© IVL Swedish Environmental Research Institute 2015

IVL Swedish Environmental Research Institute Ltd.,

P.O Box 210 60, S-100 31 Stockholm, Sweden

Phone: +46-8-598 563 00 Fax: +46-8-598 563 90

www.ivl.se

This report has been reviewed and approved in accordance with IVL's audited and approved management system.

Table of Contents

Summary	3
Sammanfattning	4
1 Background and goal of the project	5
1.1 Purpose of the project	5
2 Conclusions of the project	5
3 Test results and discussion	6
3.1 Separation of pharmaceuticals from wastewater	6
3.2 Treatment of flue gas condensate for recycling	7
3.3 Energy analysis of the membrane distillation pilot	13
3.3.1 Permeate flow rate (yield)	13
3.3.2 Specific heat demand analysis	15
3.3.3 MD-district heating integration cases and analysis	16
3.3.4 Heat losses from the MD modules	20
3.3.5 System requirements and costs for anticipated large scale production	21
3.4 Considerations on uncertainties in methods and results	22
3.4.1 Physical factors	22
3.4.2 Chemical analysis	22
4 Equipment and methods	23
4.1 Membrane distillation equipment	23
4.2 Flue gas condensate tests	24
4.3 Sampling	26
4.4 Chemical analysis	26
4.4.1 Method for analysis of pharmaceuticals	26
4.4.2 External analyses during flue gas condensate tests	26
4.4.3 Internal analyses during flue gas condensate tests	29
4.4.4 Experimental energy analysis method	29
4.4.5 Energy calculation method	31
4.4.6 Permeate flow rate analysis	33
5 References	34
6 Annex 1: Membrane Distillation	35
6.1 Characteristics of membrane distillation	36
6.2 Process configurations	36
6.3 Costs	36
6.4 Applications	37
7 Annex 2: Analysis of pharmaceuticals, ng/l	38

Summary

The purpose of the project was to evaluate membrane distillation as an alternative separation technology for different water purification applications. Membrane distillation (MD) is a unit operation that uses water repellent (hydrophobic) membranes as a barrier for contaminated water. The driving force for the process is the vapor pressure over the membrane achieved by applying a temperature differences between a warm and a cold side. The process takes place at temperatures below 100 °C and at ambient pressure.

Pilot studies were performed at Hammarby Sjöstadsverk to test the separation of pharmaceutical residues from municipal wastewater after biological treatment as well as final treatment of flue gas condensate. In both cases, most target compounds were separated to a very high degree, often more than 90 %. The project also included energy studies that showed some potential for energy optimisation of the current equipment and provided input for energy efficient set-up, e.g. by using waste heat such as the return flow from district heating. Varying results for the single modules also indicated optimisation potential.

The project was performed in cooperation between IVL Swedish Environmental Research Institute, Xzero AB as technology provider, and KTH (Royal institute of technology) for energy studies.

Sammanfattning

Projektets syfte var att utvärdera membrandestillation som en alternativ separationsteknik för olika tillämpningar. Membrandestillation är en teknik med hydrofoba membran som barriär mot förorenat vatten. Till skillnad från många andra membranprocesser är den drivande kraften ångtrycket över ett membran, skapat av en temperaturskillnad mellan en varm och en kall sida. Därmed finns möjlighet att använda sig av restvärme för separationen, t.ex. returvärme från fjärrvärmenätet. Tekniken har förutsättningar till mycket god avskiljning av många ämnen.

Pilotförsök utfördes vid Hammarby Sjöstadsverk för avskiljning av läkemedelsrester i avloppsvatten efter biologisk rening i kommunalt reningsverk samt för slutbehandling av rökgaskondensat. I båda fallen kunde membrandestillation avskilja de flesta ämnen i mycket hög utsträckning, ofta över 90%. I projektet gjordes också en energianalys som visade ett behov för vidare energioptimering i processen. Resultaten varierar mellan olika moduler, vilket indikerar optimeringsmöjligheter även för modulerna.

Projektet genomfördes som samfinansierat projekt av IVL Svenska Miljöinstitutet tillsammans med Xzero AB som teknikleverantör och KTH (Kungliga Tekniska Högskolan) som stod för energistudierna.

1 Background and goal of the project

There is a large and increasing demand for efficient water treatment technologies in many applications such as treatment of contaminated groundwater, removal of pharmaceutical residues in wastewater, treatment of complex industrial process streams and for production of drinking water. With today's separation technologies, these separation tasks are often difficult to achieve.

Membrane distillation (MD) is a promising technique for treatment of aqueous streams. It is different from common membrane technologies as temperature is the driving force (Mar Camacho, 2013). Liquid water does not pass through the membrane; only the vapour does. Depending on the composition of the liquid and the membranes as well as operating conditions, relatively small differences in temperature can separate high concentrations of unwanted substances. When using waste heat for warming the water, the process does not have a high energy demand. Furthermore, theoretically very clean water can be achieved.

Xzero AB and Scarab Development AB are Swedish SME that have developed the membrane distillation technology that is now mature for full-scale testing for different applications, final development and evaluation.

1.1 Purpose of the project

The main purpose of the project was to perform small, full scale tests to investigate if and under which conditions membrane distillation is a competitive separation technology in specific separation tasks and if it might be a complement to existing technologies.

The main applications that were tested within this project were:

- Separation of pharmaceuticals from treated municipal wastewater
- Final treatment of flue gas condensate for possible recovery

2 Conclusions of the project

Membrane distillation was tested at Hammarby Sjöstadverk with a test unit at small full scale supplied by Xzero with Air-Gap membranes by Scarab. The tested applications were treatment of municipal wastewater after biological treatment for removal of pharmaceutical residues and final treatment of flue gas condensate for possible reuse. The main conclusions were:

- The technology as such was proven to work under the tested conditions.
- Most of the analysed pharmaceutical residues were removed with membrane distillation to a level under detection limit. Sertraline could be detected in the permeate on several test runs, but at low levels. Treatment of large flows would need considerable amounts of membranes, but for limited flows membrane distillation is a technology to consider. A treatment concept will also have to take into account the handling of concentrate.
- Partially treated flue gas condensate was purified, reaching more than 99% separation almost complete separation for most metals and high separation for ammonia after pH adjustment.

Further investigations are needed to see if the achieved water quality is sufficient for re-use in power plants, and concepts for concentrate treatment are needed as well.

- For a maximum flow of 1200 l/h, the specific electricity demand calculated is in the range of 0.35-0.65 kWh/m³. The heat demand for the current set-up and the tested applications is in the range of 100-700 kWh/m³. This total energy consumption by the air gap membrane distillation is still higher than for the corresponding pressure driven desalination methods like RO. As a large part of the energy is in the form of heat, using waste heat is an attractive option, e.g. in the presence of district heating networks or industrial waste heat. Lower values for energy demand can be reached when heat recovery from the cooling outlet is possible, i.e. internal heat recovery.
- There is potential to improve module performance as well as a need to guarantee similar performance for similar modules, as performance was inconsistent between different modules.
- Membrane distillation with its possibility for high removal of contaminants is a potential alternative to e.g. reverse osmosis, especially in cases where waste heat is available.

3 Test results and discussion

3.1 Separation of pharmaceuticals from wastewater

A number of tests (henceforth called Pharma 1 through 4) were performed treating municipal wastewater after standard biological treatment including sedimentation. The wastewater was average Stockholm wastewater. Before using it for tests, the water was pre-filtered with cartridge filter (10 µm). During Pharma 1 and Pharma 2, the water was concentrated in the feed tank (1 run) by circulation without addition of new water. In Pharma 3 new water was added when a low volume was reached in the feed tank; water was added 2 times to the same level as from the start and separated water has been replaced by new water to achieve a higher total concentration ratio. Pharma 4 was similar to Pharma 3, but new water was added to the tank 5 times.

The Pharma 1 test was performed at two different hot side temperatures, 58 °C and 73 °C, and with the same cooling temperature of about 16 °C. Permeate flow was 9.25 and 12.4 l/(m²h), respectively. This is higher than results from later experiments. No specific cause for the higher flux can be identified. As late flux values were lower, these higher values might be overestimated. A higher temperature on the hot side results in higher permeates flux, but often waste heat is available at somewhat lower temperatures, which is why two temperatures were tested. During Pharma 1 almost all pharmaceuticals were removed by the membrane distillation. Only Sertraline passed partly through the membranes, at concentrations of up to 4.6 ng/l at low temperature and somewhat higher concentration in the test at higher temperature. A possible explanation is the hydrophobic character of Sertraline, which could allow transport through the hydrophobic membranes.

In the Pharma 2 test the temperature was at 82 °C. The permeate flow varied between 11.5 and 12.6 l/(m²h). In this test, 2 of 36 analysed pharmaceuticals were detected in the permeate after membrane distillation: Metoprolol and Citalopram. The maximum measured concentrations were below 5 ng/l, near the detection limit, while the concentrations in the feed varied between 440 ng/l and 13,780 ng/l. The pH during Pharma 2 changed during the concentration step. In the concentrate it went from 7.0 to 8.5 while in the permeate it was between 6.5 and 6.9 (except for one measurement of 7.4 at half tank). The pH change might be caused by the increase in concentration.

In Pharma 3, the calculated concentration was in total about 6.5 times concentration, achieved in 3 concentration steps starting at 2074 litres of volume to 98 litres of volume in the feed-tank plus the estimated 220 litre volume in the modules and piping, i.e.. Only Sertraline could be detected in the permeate.

The analysis results for the different test runs are available in detail in Annex 2.

3.2 Treatment of flue gas condensate for recycling

The flue gas condensate tests (henceforth called Condensate 1 through 3) were performed to evaluate if membrane distillation can be used as a final treatment step for purifying partially treated flue gas condensate (henceforth called "condensate"). The condensate was taken from Bristaverket, owned by Fortum AB, which is a combined heat and power plant using household waste and by-products from the forestry industry as fuels

Condensate 1

Table 1 shows the analysis results from Condensate 1. As can be seen, most of the metals analysed were separated very well. Only copper still remained in appreciable amounts, but the concentration was reduced by about 90 %. The permeate flux from the parallel connected modules was in the range of 9.5 to 10 l/h per module for 60-63 °C feed temperatures and 15 °C cooling temperature.

Table 1. Sample analysis results from Condensate 1.

	Hg ng/L	Ca (mg/l)	Fe (mg/l)	K (mg/l)	Mg (mg/l)	Na (mg/l)	S (mg/l)	Al (mg/l)	As (µg/l)
Condensate	15	5.63	0.042	2.84	0.914	2.36	<10	0.007	<0.3
MD module 1b, 1h	1.6	0.022	<0.01	0.002	0.003	0.008	<10	<0.005	<0.3
MD module 1a, 1h	1.1	0.005	<0.01	0.001	0.000	0.001	<10	<0.005	<0.3
MD module 1a, 3h	1.1	0.003	<0.01	0.002	0.001	0.002	<10	<0.005	<0.3
MD module 1b, 3h	1.7	0.007	<0.01	0.001	0.001	0.005	<10	<0.005	<0.3
	Ba (µg/l)	Cd (µg/l)	Co (µg/l)	Cr (µg/l)	Cu (µg/l)	Mn (µg/l)	Ni (µg/l)	Pb (µg/l)	Zn (µg/l)
Condensate	10.8	0.070	0.280	0.127	3.11	78.4	1.33	<0.4	97.2
MD module 1b, 1h	0.357	0.008	<0.02	<0.06	0.579	0.089	0.084	<0.4	3.35
MD module 1a, 1h	0.151	<0.004	<0.02	<0.06	0.337	0.042	0.955	<0.4	2.60
MD module 1a, 3h	0.041	<0.004	<0.02	<0.06	0.157	<0.03	0.341	<0.4	<1.5
MD module 1b, 3h	0.161	<0.004	<0.02	<0.06	0.299	0.040	<0.05	<0.4	<1.5

Condensate 2

The second test used condensate from 2013-12-13, which had been treated by chemical precipitation, flocculation and a sand filter. The condensate was filtered through a 10 µm cartridge filter before the test.

Earlier tests had shown that the pilot plant had a very limited capacity to remove ammonia, most likely due to the equilibrium between ammonium ions and molecular ammonia (equation 1); since ammonia molecules are both small and volatile, they could easily cross both the membrane and the air gap into the permeate. We examined this hypothesis by reducing the pH of the condensate, thus trying to improve the

ammonia removal. As a lower pH would favour the non-volatile ammonium, this should improve the removal. pH was lowered during treatment using concentrated sulphuric acid (H₂SO₄).

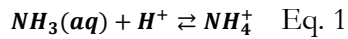

Measurements at the original feed pH of 6.1 showed about 50 % removal of ammonia (down to 100 mg NH₄-N/l). After this, the condensate was diluted with treated wastewater from the Henriksdal wastewater treatment plant (the same water that was used in the Pharma tests), to about 115 % of the original volume. The pH was then lowered with acid to study the effects on ammonia removal. It proved difficult to control the pH-value in the MD pilot plant, possibly due to some combination of insufficient mixing, slow dissolution of NaOH tablets used for pH adjustment, the effects of increased pollutant concentration in the concentrate and gradual poisoning of the pH electrode by some substance in the condensate. During the tests, the measured pH in the feed/concentrate tank varied between 2.8 and 8.5, with most values being between 3 and 5.

Figure 1 shows how the ammonium concentration in the permeate for different pH values in the feed or concentrate for tests performed in December 2013 and in March 2014. Simple on-site analyses were used, which limited the precision of the measurements, but it is clear that reducing the pH of the feed from neutral to acidic could significantly improve ammonia removal.

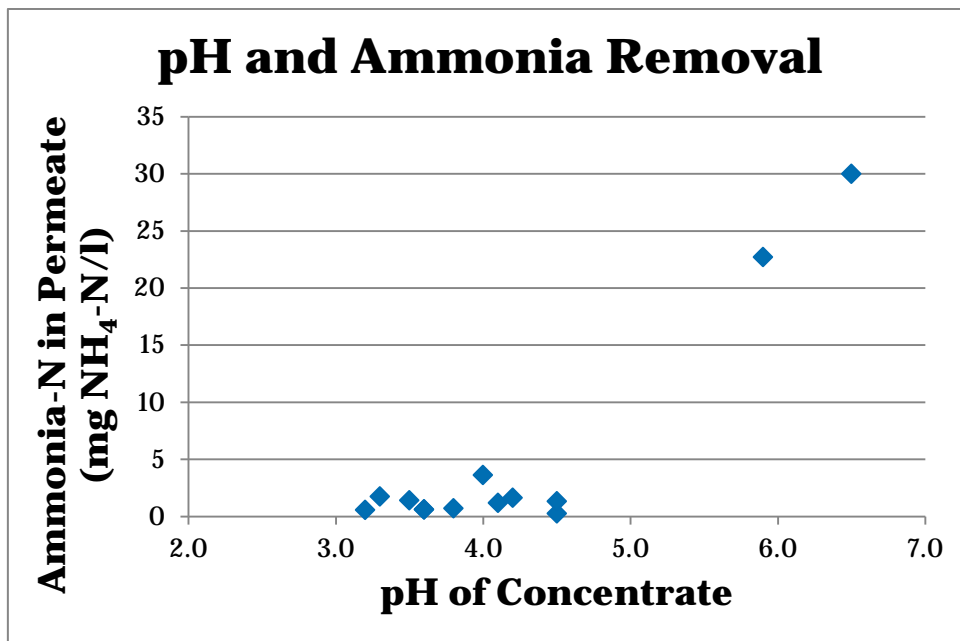

Figure 1. The effect of pH on ammonia removal. The ammonia concentration in the feed/concentrate changed over time, but the lowest measured value was 170 mg NH₄-N/l.

Samples from December 2013 were also analysed in accredited laboratories at IVL Swedish Environmental Research Institute and ALS Scandinavia. The results are shown in Table 2, and are similar to those from Condensate 1 but show a much better removal of copper as well as noticeable reduction of TOC, sulphur, boron, silicon and lead, though the detection limits are close to the initial values.

Table 2: Sample analysis results from Condensate 2.

Measurement	Unit	Concentrate	Permeate module 4
pH	-	5.75	7.36
Conductivity	µS/cm	1602	205.5
TOC	mg/l	3.3	<0.5
NH4	mg N/l	110	27
S	mg/l	230**	0.14
As	µg/l	0.38	<0.3
B*	µg/l	94.4	< 20
Si*	mg/l	0.415	< 0.04
Hg****	ng/l	91	4
Al	mg/l	0.52	<0.005
Ca	mg/l	75	0.023
Fe	mg/l	0.1	<0.01
K	mg/l	3.7	<0.1
Mg	mg/l	2.6	<0.03
Na	mg/l	44***	<0.05
Ba	µg/l	23	0.029
Cd	µg/l	0.14	<0.004
Co	µg/l	1.2	<0.02
Cr	µg/l	0.86	<0.06
Cu	µg/l	7.5	0.035
Mn	µg/l	150	0.037
Ni	µg/l	4.7	<0.05
Pb	µg/l	1.1	<0.4
Zn	µg/l	350	<1.5

*Analysis performed by ALS Scandinavia

**Most of the sulphur originates from the added sulphuric acid.

***Much of the sodium originates from the added sodium hydroxide

****Mercury concentrations may be underestimated due to the sample vial used

Condensate 3

This third test further investigated the potential for improving ammonia removal by acidification of the feed/concentrate and evaluated the performance of the system when run with a more concentrated feed solution. The lowest pH measured during the tests was 1.86.

Due to the difficulty of attaining a stable pH during Condensate 2, hydrochloric acid was used instead of sulphuric acid during most of the third test (sulphuric acid was only used for some of the later pH adjustments). For the same reason a sodium hydroxide solution was used for pH adjustment instead of tablets.

The feed consisted of 1.2 m³ of condensate from 2015-01-21 and 1 m³ from 2015-02-12, which had been treated by micro-and ultrafiltration. After the test, approximately 153 L of concentrate remained, which translates to 93 % recovery or a concentration factor of about 14.

The heated circuit was kept at about 60 °C by the return heat of district heating and the cooling circuit at about 15 °C.

Table 3. Sample analysis results from Condensate 3.

Sample	Conc. factor	Ca mg/l	Fe mg/l	K mg/l	Mg mg/l	Na mg/l	Si mg/l	Al µg/l	As µg/l	B µg/l	Ba µg/l	Cd µg/l	Co µg/l	Cr µg/l	Cu µg/l	Hg µg/l
Feed at start	1	0.51	0.029	<0.4	<0.09	1.5	<0.03	12.4	<0.6	19.5	1.43	0.025	0.049	0.75	1.97	0.47
Permeate 2	<1.1	<0.05	0.0063	<0.4	<0.09	<0.1	0.021	2.82	<0.05	0.39	0.081	<0.002	0.0058	0.04	0.24	0.003
Permeate 2, 4, 5	2.2	<0.05	0.13	<0.4	<0.09	<0.1	0.013	14.2	<0.05	2.95	0.33	<0.002	0.029	0.35	<0.1	0.068
Permeate 2, 4, 5	5.7	<0.05	0.0095	<0.4	<0.09	<0.1	0.029	19.2	<0.05	1.87	0.046	<0.002	<0.005	1.2	0.30	0.064
Permeate 2, 4, 5	13.9	0.492	0.43	<0.4	<0.09	3.72	0.022	73.6	<0.05	7.74	0.31	0.0064	1.21	72.6	14.9	0.14
Permeate 2	13.9	0.1	0.0	<0.4	<0.09	0.2	0.0	3.2	<0.05	6.7	0.1	<0.002	0.0	0.9	0.3	0.1
		Mn µg/l	Mo µg/l	Ni µg/l	P µg/l	Pb µg/l	Sr µg/l	V µg/l	Zn µg/l	S mg/l	pH	Cond. µS/cm	TOC mg/l	NH4-N mg/l	Cl mg/l	SO4 mg/l
Feed at start	1.0	5.24	0.21	0.92	26.8	0.577	<2	0.069	40.6	3.14	3.16	186	0.83	140	-	-
Permeate 2	<1.1	0.072	<0.05	0.65	5.17	0.16	<2	0.018	17.2	<0.2	3.69	4.33	1.25	0.11	-	-
Permeate 2, 4, 5	2.2	0.90	<0.05	1.36	2.26	0.57	<2	0.027	19.7	<0.2	3.87	10.7	0.62	0.25	1.04	0.39
Permeate 2, 4, 5	5.7	0.28	0.063	0.79	1.21	0.056	<2	0.011	7.59	<0.2	5.43	3.19	<0.50	0.15	0.48	0.09
Permeate 2, 4, 5	13.9	10.5	3.4	48.3	7.25	3.33	0.66	0.25	395	1.53	4.69	11.4	1.14	5.46	18.4	5.43
Permeate 2	13.9	0.4	1.5	1.5	1.2	0.1	<2	0.0	55.2	<0.2	5.9	2.7	1.0	0.5	1.1	0.3

Initially only modules 1 and 2 of the 10 membrane modules were used, as there was a risk that the low pH values could be harmful to the modules. Module 1 proved to be unreliable (there had been problems with this module during earlier tests as well) and was shut down before it was sampled. Modules 3 to 5 were started later, but conductivity measurements on module 3 indicated malfunction. Therefore most of the analysed samples were equal mixtures of the permeates from modules 2, 4, and 5.

For most of the analysed metals, the concentration in the permeate was very low or below the detection limit during the first phase of concentration, keeping in mind that the concentrations of several compounds were already quite low in the feed. Only when reaching the final concentration factor of 14

times the concentrations had started rising, often significantly compared to the earlier samples, but the concentrations still remained at low levels. The ammonium concentration showed the same behaviour. It has to be noted that several metals had a higher concentration in the final permeate than in the original feed, but a much lower concentration than in the final concentrate. The removal rate at concentration factor of 14 was still high for almost all compounds, mostly above 99 percent as shown in Figure 2. Only mercury had a comparatively low removal; this might be due to the volatility of mercury.

There are several possible explanations for the higher permeate concentrations at the end of the test. The separate analysis of permeate from module 2 showed a far better separation than the composite sample. For example, the ammonium concentration was more than ten times lower in the permeate from module 2. This might be due to variations in the modules, or some malfunction in one of the modules that was not so obvious that it could be recognised from operational data. Contamination of the sample is another possible explanation, but unlikely. It should be noted that module 2 still showed higher concentrations than the feed for a number of metals.

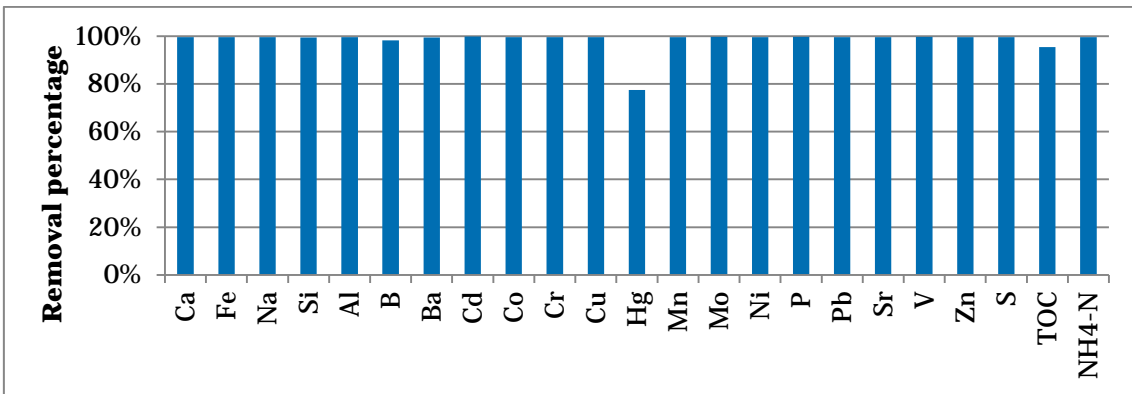

Figure 2. Percentage removal of several substances at a concentration factor of 14.

During Condensate 3 the permeate conductivity varied over time and between modules, as shown in Figure 3 (the less well performing module 3 is not shown). At the end, the conductivity is kept below 10 $\mu\text{S}/\text{cm}$.

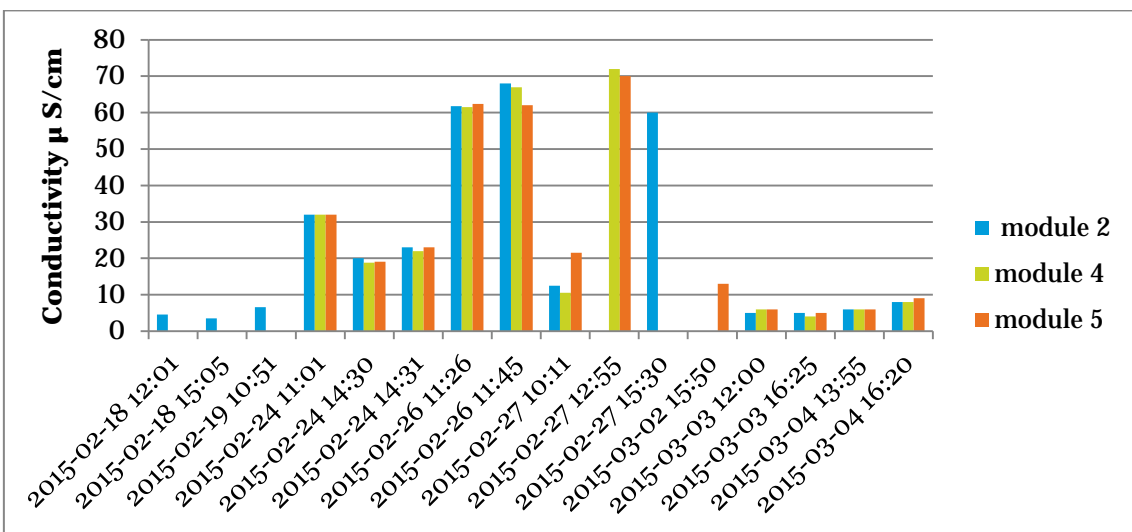

Figure 3. Permeate conductivity for different modules during the Condensate 3 test.

Requirements on feed water for Bristaverket are listed in Table 4. The feed water is currently produced by means of reverse osmosis. Although membrane distillation provides an efficient separation, the target values were not completely met in these tests. An additional treatment step or possibly a different pre-treatment would be necessary to meet e.g. the pH target.

Table 4. Specifications for CHP feed water at Bristaverket

Total conductivity	$\mu\text{S}/\text{cm}$	0.5 - 1
Acidic conductivity	$\mu\text{S}/\text{cm}$	< 0.2
pH	pH	9.2 - 9.6
Oxygen	$\mu\text{g}/\text{L}$	< 5
SiO ₂	$\mu\text{g}/\text{L}$	< 10
Sodium	$\mu\text{g}/\text{L}$	< 5

3.3 Energy analysis of the membrane distillation pilot

In the previous sections of this report, it was shown that an air gap membrane distillation system has been utilized and found to be highly effective in removing pharmaceutical residues from treated wastewater and, with proper pre-treatment, has potential for flue gas condensate treatment. The quality of permeate that could be obtained from the process is just one important parameter in evaluating the performance of membrane distillation and its feasibility for the desired water treatment applications. The other major issue to be considered in the study of membrane distillation for large scale applications is the analysis of energy demand. In the Nordic context, district heating networks can play a major role in providing heat to membrane distillation systems of small to large scale facilities in addition to industrial waste heat. Here large scale industrial application depends on efficient use of the available heat from supply and return lines of the district heating network.

In this section of the report, the focus will be on analysis of the thermal energy demand for the Xzero MD pilot plant along with system design for integrating MD with district heating networks. The energy demand and related economic issues of the MD process are also analysed in this part of the study.

3.3.1 Permeate flow rate (yield)

In these tests, the modules were connected in series of 2 modules each, which could be run with up to five parallel pairs of modules.

The permeate flow rate was measured at different module feed and cooling temperatures. A summary of the permeate flow rate is given in Figure 4. The permeate yield increases with increasing difference in temperature between module feed and cooling water. The highest permeate flux (31 l/h) was obtained for high (80 °C) module feed temperature and low (15 °C) cooling water temperature. The minimum permeate flow rate obtained was for the smallest temperature difference between cooling and module feed temperature i.e. 9.2 l/h at 65 °C and 45 °C temperature for module feed and cooling water, respectively. As the temperature difference between module feed and cooling water is reduced, the vapor pressure difference across the membrane will be lower which in turn reduces the permeate flux. The increase from 15 °C to 50 °C in cooling water temperature reduced the permeate flux from about 30 to 16 l/h at a constant module feed temperature of 80 °C.

The permeate flow rate at 65 °C module feed temperature and 15 °C cooling water temperature is found to be lower than what would be linearly predicted, which could be attributed to the higher module feed concentration during the concentrating steps of pharmaceutical residues test, which in turn causes the partial vapor pressure of water to decrease.

Both the module feed and cooling water that leaves the first module continues to the second module and so permeate flow from the second module is lower (roughly 40-65 % of the first module).

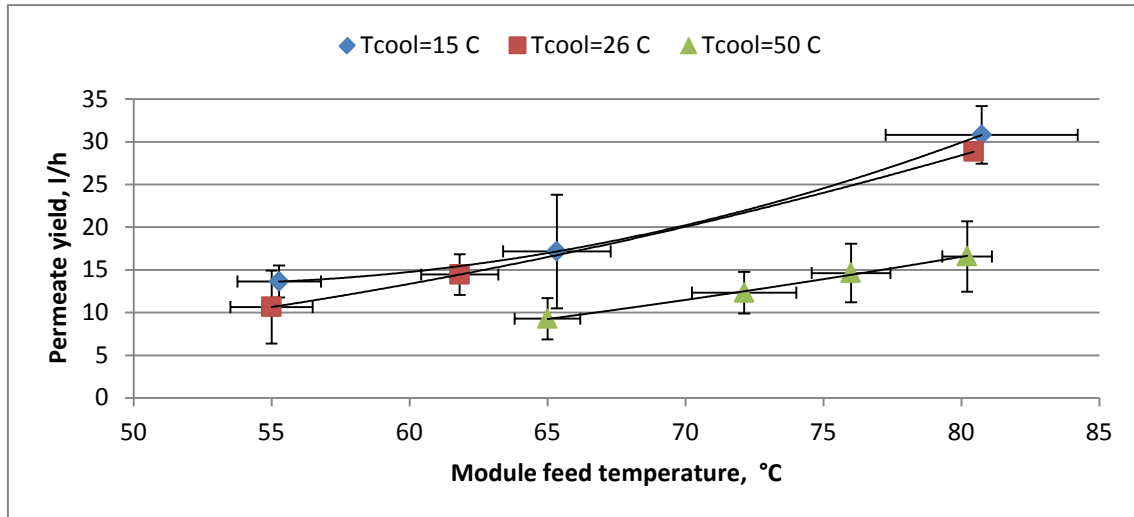

Figure 4. Permeate flow rate at different permeate feed and cooling water temperatures with 1200 l/h module feed and cooling flow rates.

Another important parameter is the module feed flow rate which also has a positive relationship with permeate flow rate. A series of four different flow rates (600 to 1200 l/h) were analysed at the same module feed temperature (80 °C) and cooling water temperature (15 °C). The permeate yield for different flow rates of module feed and cooling water is summarized in Figure 5. An increase in the flow rates increases the permeate production rate as well. Even though high feed pumping speed could increase the permeate flow rate, there was an increase in the pressure drop across the membrane and a pressure limit (0.20 bar) set by the manufacturer was reached when the module feed rate was 1200 l/h, which limits the maximum feed flow rate this point.

Knowing the extent of the module feed flow rate effect on the permeate yield contributes to the design of the pumping system. For maximum flow of 1200 l/h, the specific electricity demand calculated is in the range of 0.35-0.65 kWh/m³, given that such conditions were justified for most or all applications with this MD module type.

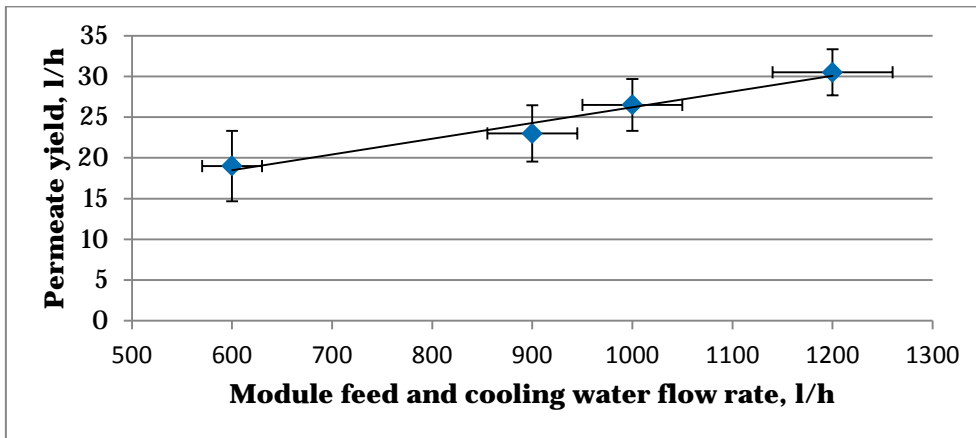

Figure 5. Permeate yield at different module feed and cooling water flow rates (600-1200 l/h) at constant module feed temperature of 80 °C and cooling water temperature of 15 °C.

3.3.2 Specific heat demand analysis

The results of the thermal energy analyses are summarized in Figure 6 for constant module feed and cooling water flow rates of 1200 l/h. Three different cooling water temperatures were tested; 15, 26 and 50 °C. The specific input of thermal energy appears to increase slightly with increasing module feed temperature at constant cooling temperature. This can be explained in terms of the heat transferred to the cooling water and heat loss to the modules' surroundings. The effect of increasing module feed temperature on the thermal energy demand is actually the result of both increases in permeate flux and heat losses.

The specific heat demand per cubic meter of permeate without any heat recovery was found to be 620-736 kWh/m³. This range was calculated using the highest tested module feed temperature of 80 °C and lowest cooling water temperature of 15 °C. The maximum thermal energy demand was found at 15 °C cooling and 80 °C module feed temperature and the minimum at a module feed temperature of about 55 °C and cooling water temperature of 26 °C (similar for module feed temperature of 72 °C and cooling water temperature of 50 °C). The heat demand decreases slightly with an increase in the cooling temperature from 15 to 26 °C. We recall from the permeate yield results that this increase in cooling temperature had very little effect on the permeate yield as well. In general, the specific thermal energy demand showed a slight increase with increasing module feed temperature but decreased with increased cooling water temperature as summarized in Figure 6.

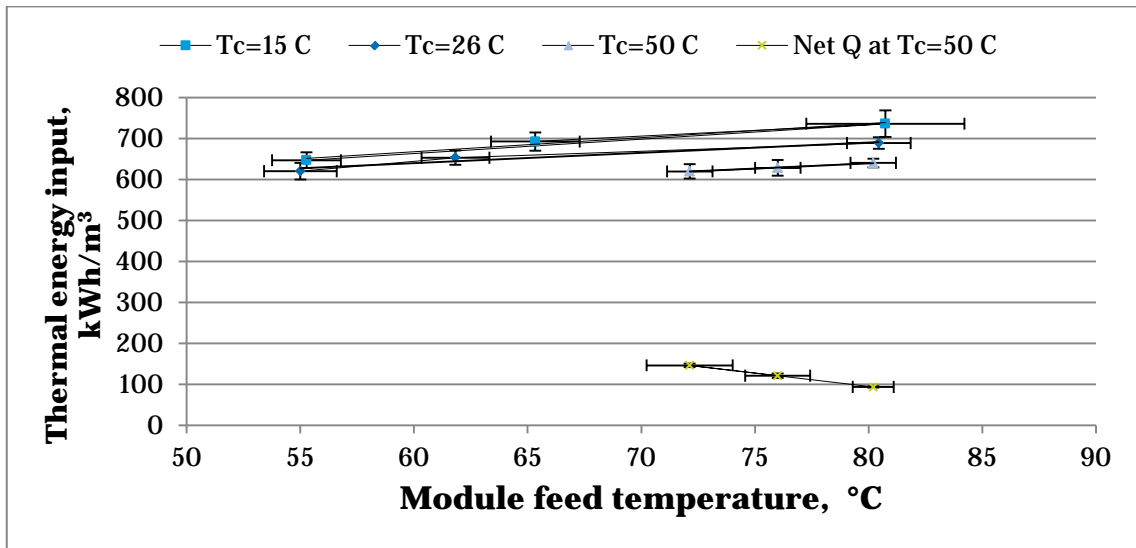

Figure 6. Specific thermal energy input at 1200 l/h module feed and cooling water flow for different module feed and cooling water temperatures.

The net heat demand for the MD process will be much lower at cooling water temperatures of 50 °C or higher, due to possible heat recovery from the cooling side outlet.

The heat demand of the MD process depends mainly on the temperature and flow rates of both the module feed and cooling water. At higher temperature and flow rate of module feed water, the permeate flow rate increases as well, which is good for reducing the number of modules required for a particular production capacity.

3.3.3 MD-district heating integration cases and analysis

In this section, three different cases of integrating an MD system with district heating network (DHN) lines are presented based on the different temperatures that are available to and from the district heating network. These three cases are

1. MD unit connected to a lower temperature (70-55 °C) district heating (DH) return line (current setup at Hammarby Sjöstadsværk)
2. MD unit connected to a high temperature (110-70 °C) DH supply line and lower temperature heat is supplied to an end user after the MD system
3. MD unit is connected to a high temperature (110-70 °C) DH for heating the module feed and connected to the low temperature DH return line as cooling water

In these three possible integrations, the MD system always obtains heat from the DHN, whether connected to the supply side or the return side. Data obtained from the previous section is used in these calculations. Each of these cases will be presented in the following sections.

3.3.3.1 Case 1: MD connected to DH return line

In this set up, the MD system is connected to the return line of district heating through heat exchangers. This 70-50 °C stream of water returned from end users is to be directed to a heat sink: CHP plant operators prefer lower return temperatures as this leads to higher electricity production and enhanced profitability via green certificates. Shown in figure 7, this is the setup currently used at Hammarby Sjöstadsværk and the experimental tests described above were all conducted using this setting. Heat exchanger pinch temperature is 5 °C.

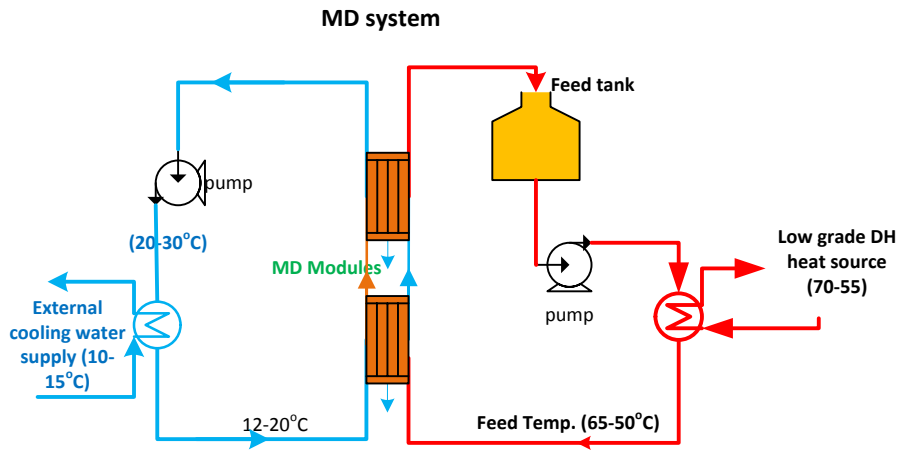

Figure 7. The present configuration at Hammarby Sjöstadsvverk, with a MD system connected to a DH return line.

Assuming a module feed temperature at an intermediate temperature level (65 °C), the specific thermal energy demand was analyzed for three cooling water temperatures (15, 30 and 45 °C). The flow rates for both the cooling water and the module feed were taken as 1200 l/h. The specific thermal energy demand decreases with increased cooling water temperature, as shown in figure 8.

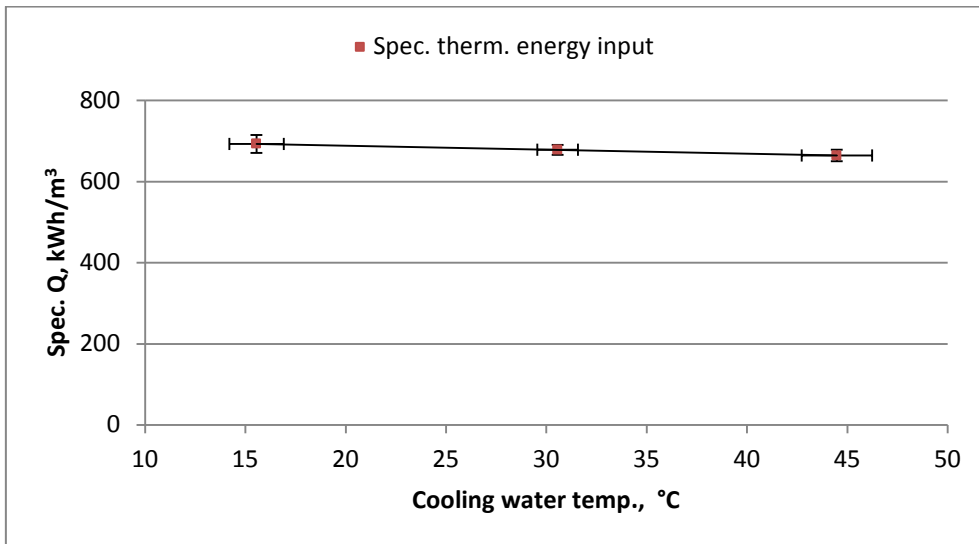

Figure 8. Case 1: Specific thermal energy input for different cooling water temperatures at 65 °C module feed temperature and 1200 l/h flow rates of both module feed and cooling water.

The low cooling temperature gives higher permeate yield and the specific thermal energy demand is higher (around 680 kWh/m³). This approach of integrating MD to the DH network could possibly be considered to have a lower cost of thermal energy, as the low temperature DH water stream can be accessed at lower cost than a high grade heat source.

3.3.3.2 Case 2: MD connected to DH supply line

When the MD unit obtains heat from the DH supply line, the incoming DH water temperature can reach up to 110°C, and returning temperature after the MD can be as high as 90 °C, which means the water can be directed to another end user or MD unit as shown in figure 9.

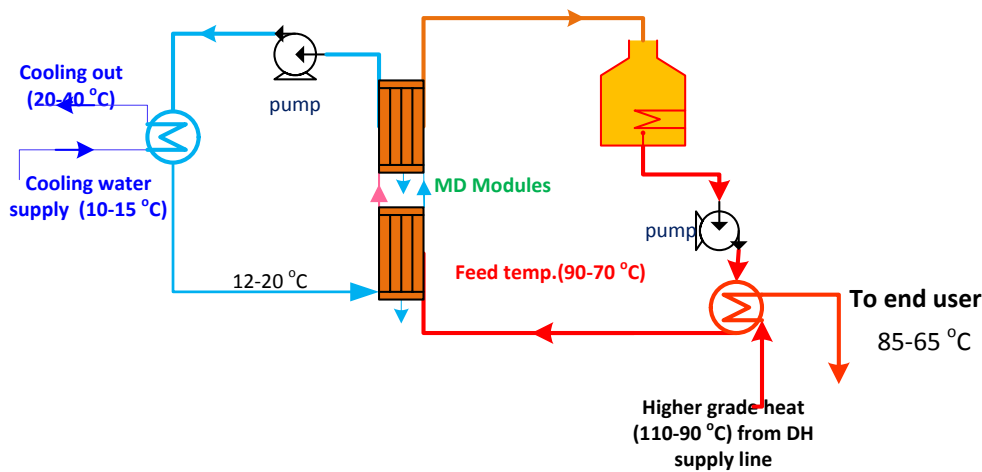

Figure 9. Case 2: Configuration with a MD system connected to a DH supply line.

The module feed temperature can vary from about 70 up to 90 °C, depending on the heat from the district heating line, which in turn varies over the seasons. This configuration uses external cooling water supplied at a relatively low temperature (15 °C). The overall temperature levels lead to larger permeate yields than in Case 1.

As shown in figure 10, the specific thermal energy demand at this module feed temperature is found to be around 700 kWh/m³, slightly higher than at a module feed temperature of 65 °C. This can be due to the higher heat transfer to the cooling water and permeate from the membrane. However, the permeate yield is also higher.

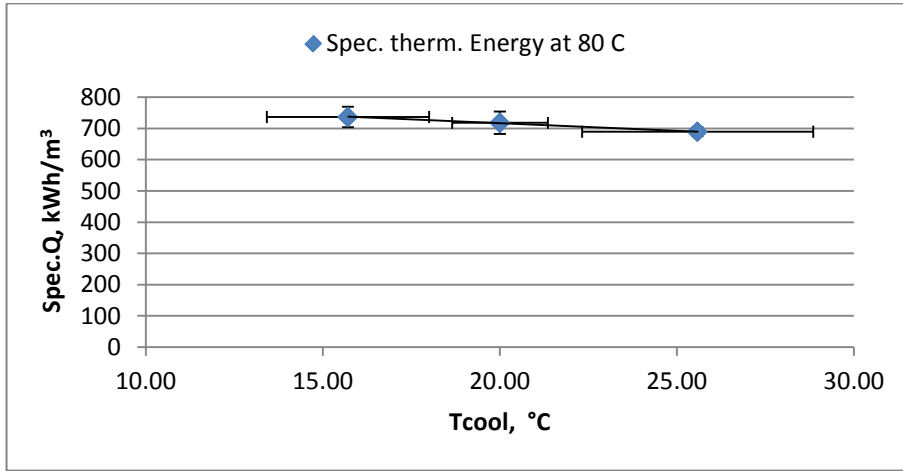

Figure 10. Case 2: Thermal energy input when module feed temperature is 80 °C and cooling water temperature varies from 15 to 25 °C.

3.3.3.3 Case 3: MD connected between DH supply line and return line

Case 3 is another possibility where the MD is connected to the DH line on both the hot and cool sides as shown in figure 11. Here the module feed water gets higher grade (up to 90 °C) heat from the DH supply line and the cooling water from lower temperature range (35-50 °C) water of a DH return line from end users. No other external cooling water source is assumed.

In this case both the module feed and cooling water temperatures are relatively high and the permeate yield from this case is nearly equal to Case 1, where both module feed and cooling water temperatures were lower. As shown in figure 12, the specific thermal energy demand is around 640 kWh/m³, which is slightly lower than in Case 2. This approach to MD integration has an additional advantage of supplying heat from the relatively high temperature DH return line, in addition to favorable heat gain from the DH supply line. Because of this possibility of recovering heat, the net specific thermal energy demand is low, around 150 kWh/m³.

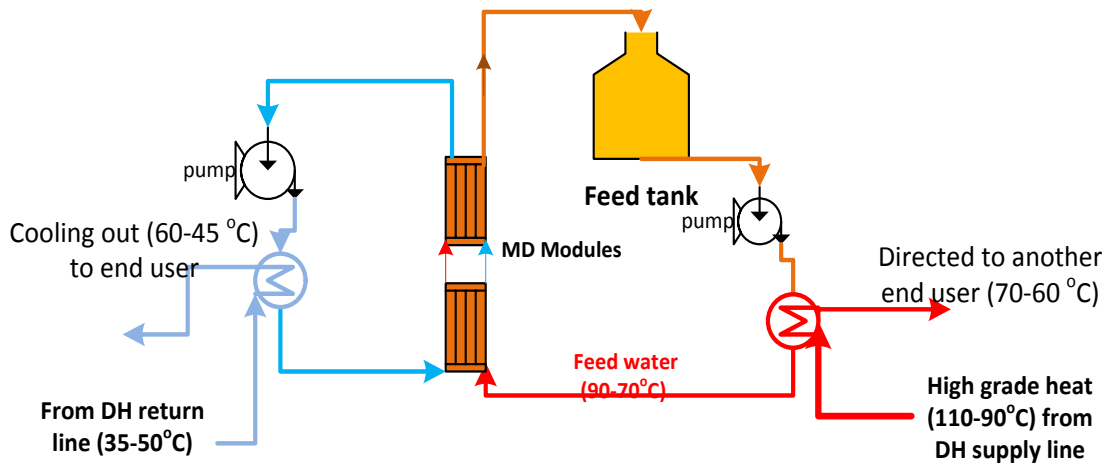

Figure 11. Case 3: Configuration with MD placed between DH supply and return lines.

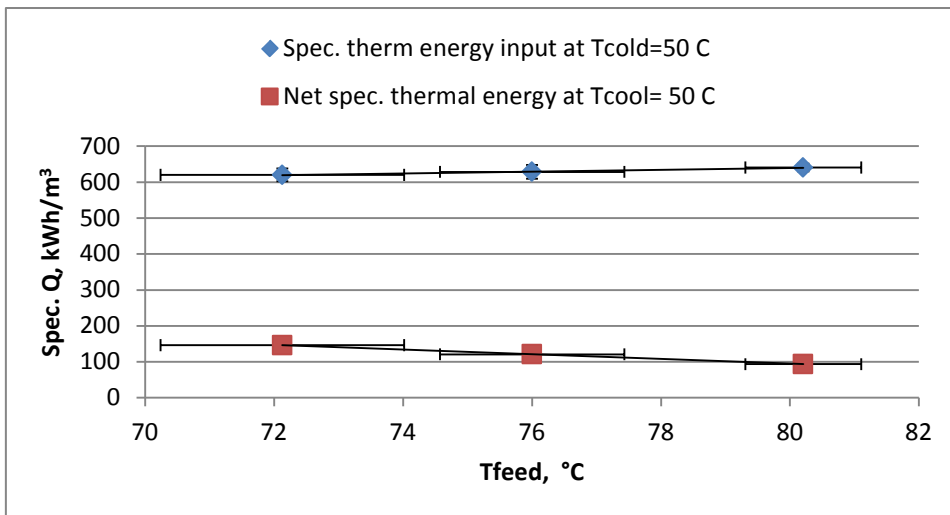

Figure 12. The input and net specific thermal energy demand of the MD system in Case 3.

3.3.4 Heat losses from the MD modules

Heat loss from the surface of the module by free convection was considered in addition to heat loss through the permeate. Free convection was considered as the main source of heat loss to the surroundings. This is because there was no ventilation near the modules that would affect the movement of air around the MD modules. The heat transfer rate due to natural convection was determined using Eq. 6 from section 4.4.5. The calculated value of the heat transfer coefficient (h) for this free convection by air was in the range of 1 to 6.5 W/m²K, which is in the lower range of heat transfer coefficient values for natural convective cooling by air. The convective heat loss showed a slight increase with increased cooling temperature for constant module feed temperature, which is due to the increase in the temperature of the module surface. The two major heat losses considered are summarized in table 5.

Table 5. Heat loss through permeate and through free convection given as kWh/m³ of produced permeate at different module feed and cooling water temperatures.

Cooling temp. °C	Feed temp. °C	Perm. temp. °C	Spec. Qp, kWh/m³	Spec. Qconv. kWh/m³	Total heat loss, kWh/m³
15	55	35	17	15	32
15	65	39	23	15	38
30	65	47	32	20	52
45	65	54	39	27	66
15	80	48	32	9	41
25	80	52	38	11	49
50	80	64	52	21	73

The heat loss through permeate and free convection would be highest in Case 3, where both module feed and cooling water temperatures are high, since this makes the permeate and cover plates of the modules warmer and thus lose more heat to the surroundings than in the other two cases. The lowest heat loss to the surroundings is achieved in Case 1 where both the module feed and cooling water temperatures are the lowest, which leads to low permeate and cover plate temperatures.

3.3.5 System requirements and costs for anticipated large scale production

We can estimate the system requirements in terms of the number of MD modules required for a system that can produce 10 m³/h of permeate per hour. This estimation relies on a linear relationship between the number of modules and the permeate yield. Table 6 contains the key data for the three cases investigated. The number of modules required is highest for Case 1 and Case 3 (which have low yields) and lowest for Case 2, which is most favourable from a yield perspective.

Table 6. Summary of thermal energy demand and the number of modules required for a permeate yield of 10 m³/h.

Case	Feed temp. °C	Cooling temp. °C	Specific thermal energy, kWh/m³			No. of modules for 10 m³/h production capacity
			Input	Recovered	Net	
2	80	15	737	0	737	644
1	65	15	692	0	692	1176
3	80	50	640	534	106	1212

A small amount of electrical energy is also required for running the pumps for the module feed and cooling water. The specific electrical energy demand for each of the two pumps was calculated using Eq. 7 in section 4.4.5 and was found to be 0.65 kWh/m³.

Table 7 contains a summary of cost estimates for a 10 m³/h system for each of the three cases. The system capital cost is based on data presented by Kullab and Martin (2007) and includes skid, MD modules, pumps, heat exchangers, tank, electrical equipment, piping, and other items. For the present study capital cost is assumed to be linearly proportional to the number of modules. The cost of water in this case is

higher than what was found in Kullab and Martin (2007). It could be that costs were higher in the present case since Kullab and Martin assumed very low net specific thermal energy consumption. Such a low value has not been achieved but could be approached in Case 3, if heat losses could be reduced and if permeate heat exchange is employed. The capital costs for purified water production can be estimated based on an estimated five years life time form the membranes and a fifteen year operational span of other MD equipment in the system.

Table 7. Total specific cost estimation for a 10 m³/h permeate yield capacity MD system.

case	Capital cost (MSEK)	Specific heat cost (SEK/m³)	Specific electric cost (SEK/m³)	Other O&M (SEK/m³)	Total spec. cost (SEK/m³)
1	13.9	207	0.52	2.8	224
2	7.6	368	0.52	1.5	377.5
3	14.4	53	0.52	2.9	70,8

3.4 Considerations on uncertainties in methods and results

The tests and analyses within this project have been performed with thoroughness, but still uncertainties are inevitable.

3.4.1 Physical factors

Measurements of temperature have been performed with robust instruments and were estimated to have a high degree of accuracy with probably less than 10 % error. The Pt100 temperature sensors attached to the plant that were used for energy calculations ha ± 0.2 °C accuracy.

Concentration factors have been calculated from concentrate volumes based on measurements of the height of the surface in the main tank. The volume of water in the piping and modules could not be determined exactly. Thus it is estimated that volume calculations and concentrations factors have a possible error of 10% or higher.

The membrane area has been specified by the supplier and is assumed to be within less than 5 % deviation of the nominal value.

The flow rates of permeate have been measured by hand by collecting a litre of permeate and measuring the time required. Variations in the permeate flow might occur, but were not expected suddenly. Thus the error is estimated to be around 5%.

3.4.2 Chemical analysis

The accuracy of chemical analysis of pharmaceuticals varies with different substances. For the substances analysed in this project, standard deviation varies from 6 to 21 percent, with an average of 13 percent. This is based on earlier investigations with 4 spiked samples.

For the analysis of the condensate samples, the external laboratory states the measurement accuracy for each compound.

4 Equipment and methods

4.1 Membrane distillation equipment

As part of the project, a membrane distillation unit with 10 membrane modules was designed and constructed. The unit was placed at the test and demonstration facility Hammarby Sjöstadsværk, where new technologies for water treatment, sludge management, and biogas production are developed and demonstrated.

The first design of the equipment was proposed by Xzero. Then some adaptations and improvements to fit the equipment for the installation at Hammarby Sjöstadsværk were made. As the unit had to be placed on top of other equipment, the MD equipment was placed at about 2 m height. An illustration of the equipment is shown in figure 13, the process scheme in figure 14.

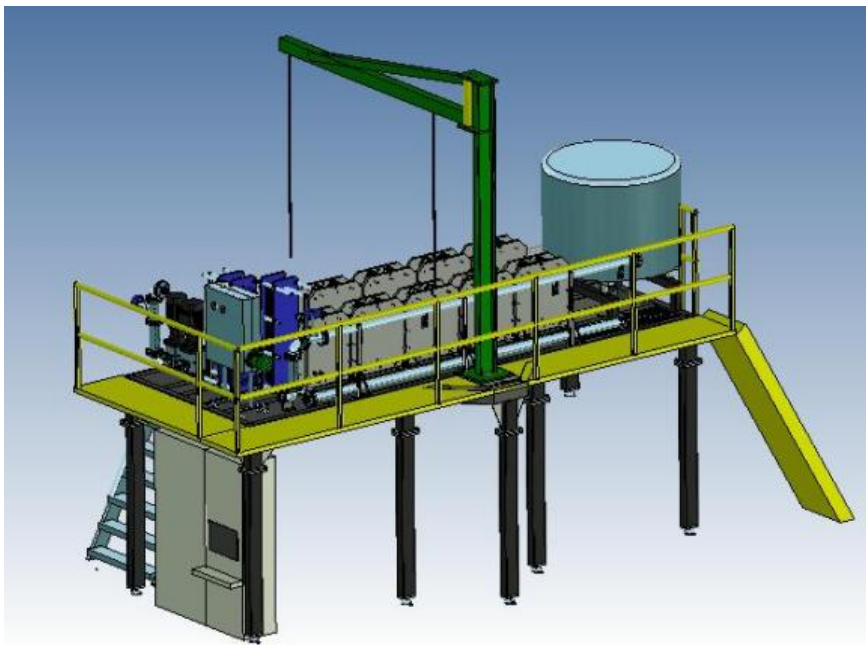

Figure 13. Illustration of the membrane distillation installation at Hammarby Sjöstadsværk.

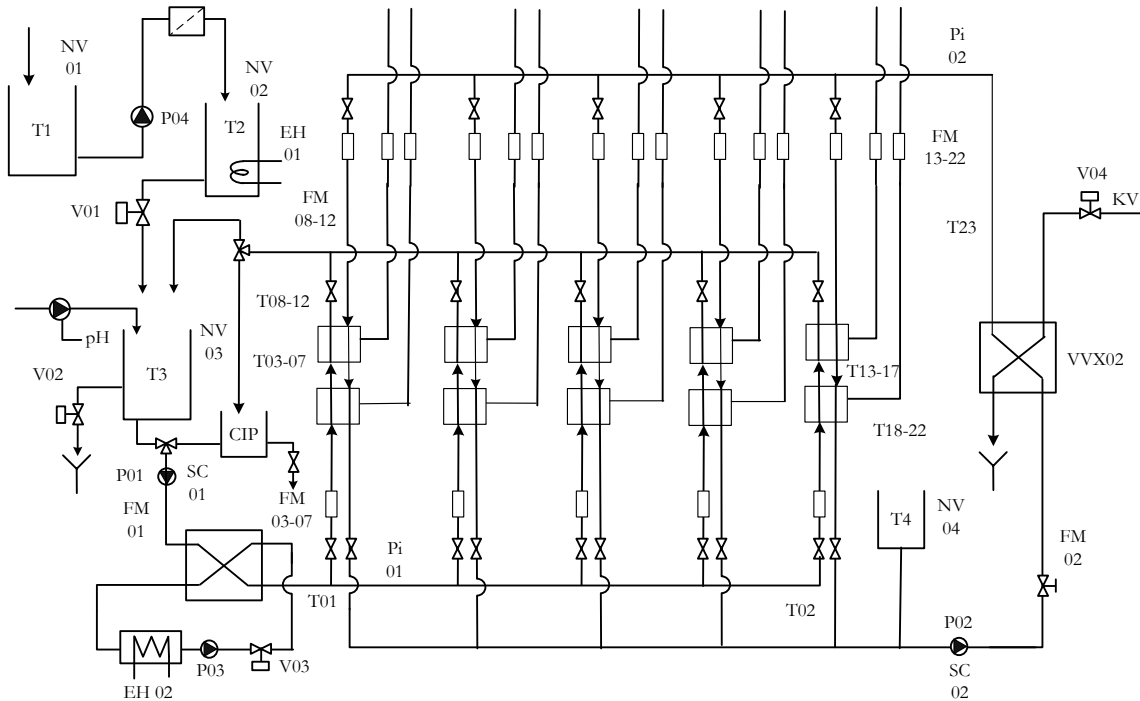

Figure 14. Process scheme for the MD plant at Hammarby Sjöstadsverk (the modules could also be reconnected to run either in series or individually).

The modules were designed by Xzero. They were based on the air gap membrane distillation principle and were designed to reduce heat loss. The active membrane area for each module is 2.3 m² (with a total area of 2.8 m²). PTFE membranes with PP nonwoven backing were. Primary membrane characteristics were 0.2 mm thickness, 0.2 μm average pore size, and 80 % porosity.

During experiments, data was logged for parameters connected to the control system (temperatures and certain flow rates). Furthermore, the volume treated was noted as well as the permeate flow from the modules in use.

4.2 Flue gas condensate tests

Flue gas condensate has been investigated by KTH in earlier tests (Kullab and Martin, 2007). The purpose of these trials was to investigate the potential of improved technology. Partially treated flue gas condensate (hereafter called “condensate”) was taken from Bristaverket, owned by Fortum AB, which is a combined heat and power plant using household waste and by-products from the forestry industry as fuels. The plant uses flue gas condensation to increase its energy efficiency, and the treated flue gas condensate is released into a nearby recipient. The plant has very strong quality targets for the water that is released (during the project the flue gas condensate treatment at the plant was upgraded, with reverse osmosis as the new final treatment step) and produces large amounts of heat, which could make it an interesting application for membrane distillation.

The condensate used in the tests came from Bristaverket’s Line 1, which uses wood chips as a fuel. This condensate contains unusually high amounts of ammonium, which comes from the line’s SNCR (selective

non-catalytic reduction) treatment for reduction of nitrogen oxide emissions. The Condensate 1 used condensate from 2013-03-30, Condensate 2 used condensate from 2013-12-13 and Condensate 3 used condensate from 2015-01-21 and 2015-02-12. The first two batches had been treated by chemical precipitation, flocculation and a sand filter. The treatment was changed between Condensate 2 and Condensate 3, and the batches for the third test had been treated by microfiltration followed by ultrafiltration.

All flue gas condensate was pre-filtered with a cartridge filter (10 or 0.5 µm) before the tests to avoid clogging and mechanical damage within the MD system.

The removal of metals and sulphur was studied in all tests. Condensate 2 focused on improving ammonia removal, and Condensate 3 focused on further improvement of ammonia removal and the effects of high a concentration factor.

Condensate 1

The first test used condensate from 2013-03-30, which had been treated by chemical precipitation, flocculation and a sand filter. The flue gas condensate was pre-filtered with cartridge filter (10 µm) before membrane distillation. The permeate flux from the parallel connected modules was in the range of 9.5 to 10 (l/h) per module for 60-63 °C module feed temperatures and 15 °C cooling water temperature.

Condensate 2

The second test used condensate from 2013-12-13, which had been treated by chemical precipitation, flocculation and a sand filter. The flue gas condensate was filtered through a 10 µm cartridge filter before the test.

Early tests had shown that the pilot plant had a very limited capacity to remove ammonia, most likely due to the equilibrium between ammonium ions and molecular ammonia (equation 1). Since ammonia molecules were both small and volatile, they could easily cross both the membrane and the air gap into the permeate. We examined this hypothesis in the second test by reducing the pH of the condensate thus trying to improve the ammonia removal. A lower pH would favour the non-volatile ammonium, which should improve the removal.

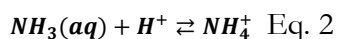

pH was lowered before the treatment using concentrated sulphuric acid (H₂SO₄). Further pH adjustment during the treatment was done using concentrated sulphuric acid and solid sodium hydroxide tablets (NaOH). pH was kept above 3 to avoid possible damage to the membranes.

Condensate 3

The third test used condensate taken on 2015-01-21 and on 2015-02-12. These had been treated by microfiltration followed by ultrafiltration (the following step at Brista's treatment line would have been reverse osmosis). The condensate was filtered through a 0.5 µm cartridge filter before the test.

The purpose of the third test was twofold: to further investigate the potential of improving ammonia removal by acidification of the feed and to evaluate the performance of the system when run with a more concentrated feed solution. It was decided to try to reduce the pH value down to 2, which would also give

information about how the system would perform at low pH, which had not been tested previously using these units. The lowest pH measured during the tests was 1.86.

4.3 Sampling

Grab samples during the condensate tests were taken using plastic bottles and checked with pH- and conductivity meters before being frozen prior to analysis.

4.4 Chemical analysis

Chemical analysis was done according to standards when available.

4.4.1 Method for analysis of pharmaceuticals

Water from Sjöstadverket (100 ml feed from the concentrate tank and 500 ml of permeate) was spiked with surrogate standard Ibuprofen-d3 and Carbamazepine-13C15N. The sample was shaken for half an hour with a small addition of EDTA before purification on a solid-phase extraction (SPE) column (200 mg Oasis HLB, Waters). The SPE column was preconditioned with methanol followed by MQ-water. Thereafter, the sample was added to the column at a flow rate of two droplets per minute. The analyses were eluted from the column using methanol followed by acetone. The sample extract was evaporated to dryness under a stream of nitrogen at 40 °C. The sample was reconstituted in methanol: water (1:1) and centrifuged before it was transferred to the vial.

The final determination of the amount of pharmaceutical residues in the samples was performed on a binary liquid chromatography (UFLC) system with auto-injection (Shimadzu, Japan). The chromatographic separation was performed on a C18 reversed phase column (dimensions 50 x 3 mm, particle size 2.5 µm, XBridge, Waters) at a temperature of 35 °C and a flow rate of 0.3 ml / minute. The mobile phase consisted of 10 mM acetic acid in water (A) and methanol (B).

UFLC system was coupled to an API 4000 triple quadrupole (MS/MS) (Applied Biosystems) with an electrospray ionization interface (ESI) applied in both positive and negative mode.

4.4.2 External analyses during flue gas condensate tests

4.4.2.1 Condensate 1 and 2

Si and B were analysed by the ICP-AES unit at ALS Scandinavia according to EPA-methods 200.7 (ICP-AES). Samples were acidified prior to analysis when needed. All other analyses were performed at IVL Swedish Environmental Research Institute.

Table 8. Analysis methods for different components from Condensate 1 and 2 samples.

Analyses	Method	Accredited
Hg	Purge and trap on CVAFS	Yes
Ca, Mg, Na, K	SS EN ISO 14911	Yes
Ammonia	FIA SS EN ISO 11732 mod	Yes
pH	SS EN ISO 10523:2012	Yes
Conductivity	ISO 27888 utg 1	Yes
TOC	SS EN 1484 utg 1	Yes
S	ICP-MS	No
Other metals	ICP-MS SS-EN 15841:2009, SS-EN ISO 17294-1 and -2:2006	Yes

4.4.2.2 Condensate 3

In order to reach as low detection limits as possible, all external analyses for Condensate 3 were performed by ALS Scandinavia or their partner laboratories. All analyses were accredited except where otherwise noted.

Table 9. Reference table for external analyses for Condensate 3. *The Cl⁻ and SO₄²⁻ analyses were not accredited, while the Si and B analyses were only accredited for the concentrate.

Analyte	Method
Ca	1
Fe	1
K	1
Mg	1
Na	1
Si*	1
Al	1
As	1
B*	1
Ba	1
Cd	1
Co	1
Cr	1
Cu	1
Hg	1
Mn	1
Mo	1
Ni	1
P	1
Pb	1
Sr	1
V	1
Zn	1
S	1
pH	2
Conductivity	3
TOC	4
NH ₄ -N	5
Cl*	6
SO ₄ *	7

Table 10. Methods used for the Condensate 3 analyses.

Method no.	Method
1	For ICP-SFMS: SS EN ISO 17294-1, 2 (mod) and EPA-method 200.8 (mod) For ICP-AES: SS EN ISO 11885 (mod) and EPA-method 200.7 (mod) For Hg: SS EN ISO 17852
2	CZ_SOP_D06_02_105 Determination of pH by potentiometry (based on CSN ISO 10523, US EPA 150.1, CSN EN 16192, SM 4500-H(+) B).
3	CZ_SOP_D06_02_075 Determination of electrical conductivity (based on CSN EN 27 888, SM 2520 B, CSN EN 16192).
4	CZ_SOP_D06_02_056 Determination of total organic carbon (TOC) and dissolved organic carbon (DOC) and total inorganic carbon (TIC) by IR detection (based on CSN EN 1484, CSN EN 13370, SM 5310).
5	NH ₄ -N CSN ISO 11732, CSN ISO 13395.
6	SS-EN ISO 10 304-1:2009.
7	SS-EN ISO 10304-1:2009.

Samples were acidified prior to analysis when needed. Samples were stabilised with hydrogen peroxide for sulphur analysis.

4.4.3 On-site analyses during flue gas condensate tests

Ammonia concentration was measured either using Hach Lange LCK 302 and Hach Lange LCK 303 cuvette tests and a DrLange XionΣ 500 spectrophotometer or using WTW Spectroquant Ammonium Cell Tests 1.14559 and 1.14739 and a WTW photoLab 6600 UV-VIS spectrophotometer. When needed, samples were diluted with deionized water to bring the concentration within the measuring range.

Conductivity was measured using either a WTW Cond 330i with a TetraCon 325 probe or an Elmacron 5000RE-Kond conductivity meter, pH was measured using a WTW pH 330i with a SenTix 41 probe.

4.4.4 Energy analysis method

The energy analyses were based on test data obtained from taking one cascade (i.e. pair of series-connected modules) at a time. The energy analysis was done on data collected for a total period of more than three hundred hours or about 40 days of intermittent operation, as the MD system was always shut down overnight. A number of tests were carried out focusing on independent variables like module feed & cooling water temperature and flow rates.

The MD system under consideration was configured with heat exchange to a district heating line as shown in figure 15. Low grade heat (50-65 °C) was connected to the feed line; external cooling water was supplied to the MD unit via another heat exchanger. If higher temperatures were desired, two 12 kW electric heaters were installed in the feed tank and could boost temperatures to up to 80 °C. Rotameters ($\pm 5\%$ accuracy) were used to measure feed and cooling water flow rates, and for the permeate turbine flowmeters ($\pm 0.1\%$ accuracy) were employed. PT100 thermocouples were used as temperature sensors ($\pm 0.2\text{ °C}$ accuracy). Experimental data was collected with a PC-based Citect SCADA system.

In terms of post-processing, acquired data was analyzed to identify steady state feed and cooling temperature values at a particular operational point. The readings over a specified period of time were then averaged and used for the heat demand calculation. Moreover, a statistic test (Q-test at 0.05 CL) was used to decide if an exceptionally large or small reading was an outlier and should be rejected. Errors or uncertainties on the reported values were calculated considering both the instrumental accuracy and standard deviations, and propagation of errors in calculation were also considered. A report on the data obtained and data treatment is provided by Woldemariam (2014).

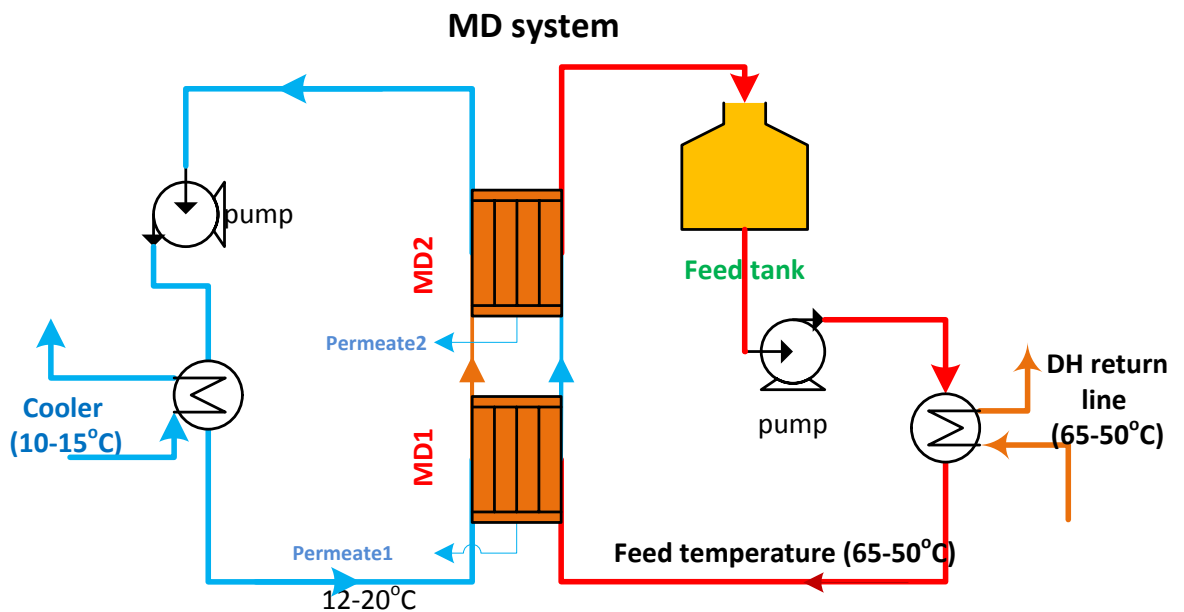

Figure 15. Configuration of the MD system with district heating at Hammarby Sjöstadverk.

The energy analysis was conducted by considering a cascade or pair of modules (total of 4.6 m² active membrane area) connected in series as shown in figure 16, the connection of which enables the system to have internal heat recovery.

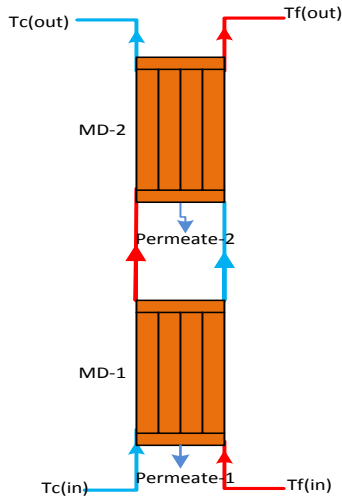

Figure 16. A cascade, consisting of a pair of MD modules connected in series.

4.4.5 Energy calculation method

The calculation of thermal energy consumed in the MD process focused on evaluating the change in enthalpy (i.e. the amount of heat input) on the feed water side in relation to possible heat recovery on the cold side. Heat losses occur through permeate flow and module interactions with the surroundings via convection and radiation. The enthalpy change in the feed channel (Q_f) and in the cooling channel (Q_c) of the membrane module can be determined using the following equations:

$$\dot{Q}_f = \dot{m}_f C_p (T_{f,in} - T_{f,out}) \quad \text{Eq. 3}$$

$$\dot{Q}_c = \dot{m}_c C_p (T_{c,out} - T_{c,in}) \quad \text{Eq. 4}$$

where \dot{m}_f and \dot{m}_c are the feed and cooling flow rates, respectively, C_p is the specific heat of the water stream and $T_{f,in}$ and $T_{f,out}$ are the temperatures of the module feed solution at the inlet and outlet of the membrane module, respectively. $T_{c,out}$ and $T_{c,in}$ are the temperatures of the cooling water leaving and entering the modules, respectively.

In this study, the net heat demand for the membrane distillation process is calculated as follows:

$$\dot{Q}_{net} = \dot{m}_f C_p (T_{f,in} - T_{f,out}) - \Phi \dot{m}_c C_p (T_{c,out} - T_{c,in}) \quad \text{Eq. 5}$$

The parameter Φ indicates heat recovery on the cold side and assumes a value of 1 for $T_{c,in}$ less than or equal to 50 °C and 0 for lower temperatures.

Hence, the net specific thermal energy demand (E_{th}) can be calculated as:

$$E_{th} = \frac{\dot{Q}_{net}}{J_w} \quad \text{Eq. 6}$$

where J_w is the permeate mass flow rate.

The total heat losses from the modules can be estimated by considering the heat content of all the water streams around the MD module i.e. the feed into and out of the module, the cooling stream into and out of the module, and the permeate yield. While the majority of heat from the feed is recovered at the cooler, non-negligible heat losses occur via enthalpy loss from the permeate and heat losses from the module surface by natural convection to the surroundings. The different heat flows around the MD modules is described in Figure 17 The heat losses through permeates were calculated using Eq. 5.

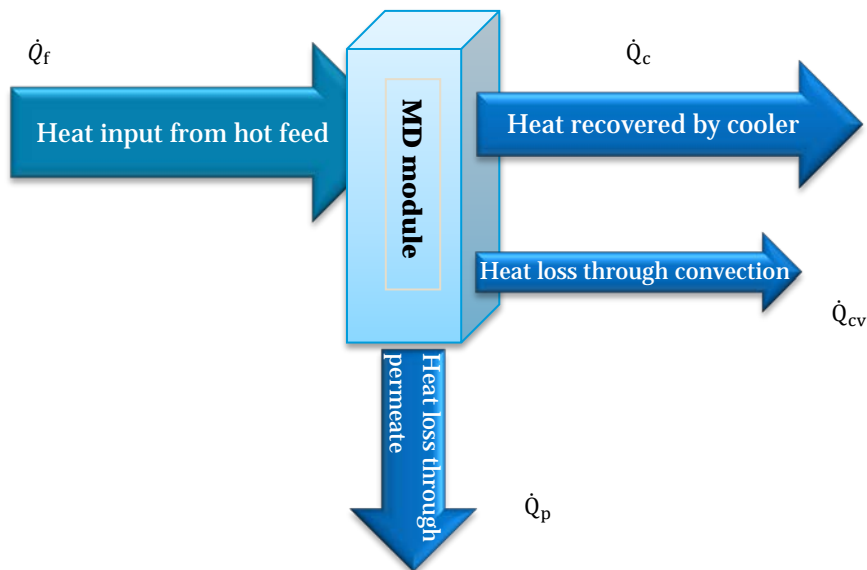

Figure 17. The different heat flows into and out of an MD module.

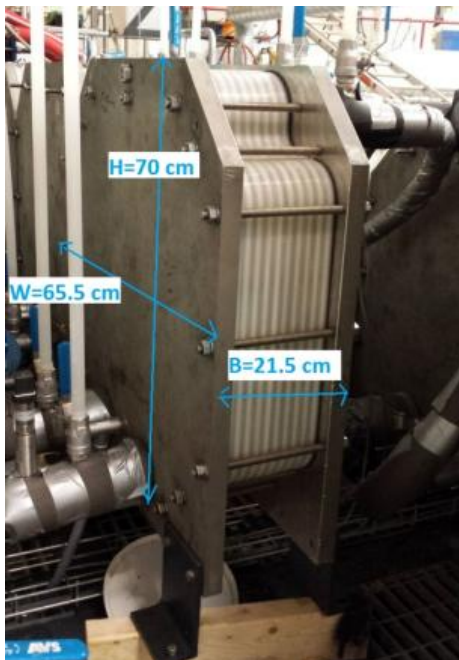

Figure 18. Dimensions of a MD module considered for heat loss calculations by free convection.

The permeate enthalpy loss can be determined from the temperature of permeate and its flow rate as follows, with reference to surrounding temperature:

$$\dot{Q}_p = m_p * C_p * (T_p - T_0) \quad \text{Eq. 7}$$

where \dot{Q}_p is the rate of heat loss through the permeate, T_p is the permeates measured temperature and T_0 is the reference temperature.

Heat loss calculation for natural convection was also considered as the module's external steel surfaces were warmer than the surrounding air. The heat loss calculation was done using Engineering Equation Solver (EES) to calculate the coefficient of heat transfer and then determining the heat transfer from the hot plates to the atmosphere very far from the module using equation 7.

$$\dot{Q}_{cv} = h * A * (T_p - T_\infty) \quad \text{Eq. 8}$$

Here, \dot{Q}_{cv} is the heat transfer rate by convection, h is the heat transfer coefficient, A is the area of the module surface and T_p and T_∞ are temperatures of the module surface and the atmospheric air far from the module respectively. The dimensions of the MD modules are shown in figure 18.

There is a small amount of electrical energy required for running the two low pressure pumps which was also calculated from the flow rates of water and differential height as follows in equation 8.

$$Q_{(kW)} = \frac{\dot{v} * \rho * g * h}{\eta} \quad \text{Eq. 9}$$

where \dot{v} is the volume flow rate in m³/h, ρ is the density in kg/m³, g is the gravitational constant, h is the differential height and η is the pump efficiency.

4.4.6 Permeate flow rate analysis

Permeate yield (J) refers to the rate of production of purified water by MD at a specified conditions (i.e. feed flow rate and temperature, cooling flow rate and temperature, membrane area, etc.). The data for the permeate yield was obtained from the flow meters and validation with manual measurement was done when noises occurred in the signal due to air bubbles. Permeate rate was calculated for cascades that consisted of two modules connected in series (4.6 m² active membrane area) as shown in figure 16.

Permeate yield is mainly affected by the feed temperature and its flow rate for constant feed sample composition, cooling water and membrane properties. In this study, feed flow rate, feed temperature, and cooling temperature were considered keeping the other parameters (membrane, feed and cooling flow rates) fixed at a time. As the test was done while concentrating treated wastewater, there can be an effect of the concentration on the permeate production rate due to increased concentrations of solids or substances in the concentrate causing increased fouling or clogging.

5 References

- Kullab, A., Martin, A. (2007). Membrane Distillation and Applications for Water Purification in Thermal Cogeneration – Pilot Plant Trials. Värmeforsk report 1029, Stockholm.
- Kullab, A. (2011). Desalination using Membrane Distillation: Experimental and Numerical Study. KTH Royal Institute of Technology, Stockholm (Trita-KRV; 11:7).
- Khayet, M., Matsuura, T. (2011), Membrane Distillation-Principles and Applications, Elsevier B.V., Oxford, UK.
- Mar Camacho et. al. (2013). Advances in Membrane Distillation for Water Desalination and Purification Applications. Water, 5, 94-196.
- M. Tomaszewska (2000). Membrane Distillation - Examples of Applications in Technology and Environmental Protection. Polish Journal of Environmental Studies Vol. 9, No. 1, 27-36.
- Woldemariam, D. (2014). Energy Analysis of Xzero's Airgap Membrane Distillation Pilot Plant: Experimental test results, <http://kth.diva-portal.org/smash/record.jsf?pid=diva2:772373>.

6 Annex 1: Membrane Distillation

Membrane distillation (MD) is a unit operation that uses water repellent (hydrophobic) membranes as a barrier for contaminated water. It is a technology that is still regarded as quite new (Tomaszewska, 2000). Khayet and Matsuura (2011) present a comprehensive overview of nearly all aspects of membrane distillation; this section highlights the primary features of this technology. The process takes place at temperatures below 100 °C and at ambient pressure.

Heated water flows alongside a microporous, hydrophobic membrane. The surface tension of the water prevents it from entering the membrane. However, part of the water evaporates and, as vapor, passes through the pores of the membrane and condenses on the other side of the membrane. Transport of vapor is driven by the difference in vapor pressure between the heated side and the cooled side. A process scheme is shown in figure 19.

Temperature levels are such that low-grade heat sources may be used to supply the required energy for the process. Unlike other membrane processes, MD does not require a mechanical pressure pump in addition to the feed and circulation pump and is not limited by the osmotic pressure.

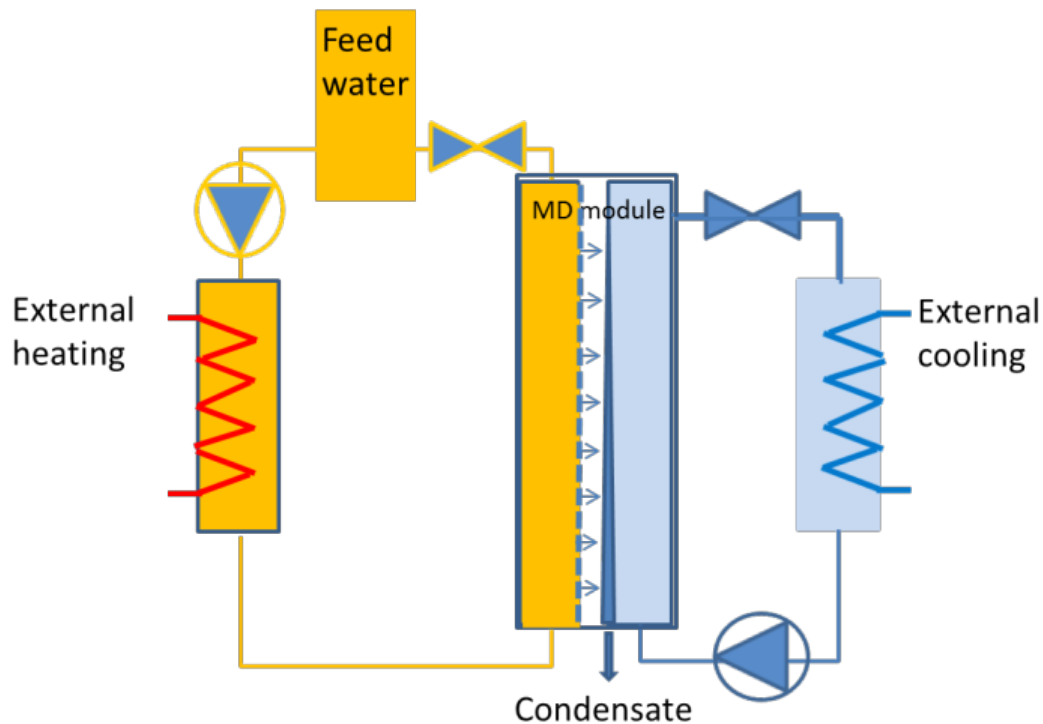

Figure 19. Simplified process scheme for air gap membrane distillation. The driving force is the difference in vapor pressure that arise due to the temperature difference

Process steps include the following (example given is for air gap membrane distillation, see subsequent process configurations):

1. Heat is transported from the bulk fluid to the water surface
2. Water molecules evaporate from the surface of the water
3. Water vapor diffuses through the membrane
4. Water vapor diffuses through the air gap to the condensate wall
5. Water vapor condenses on the condensate wall

6. Condensation heat is transported through the condensate wall to the coolant

6.1 Characteristics of membrane distillation

Since the MD process itself takes place at temperatures below 100 °C and at ambient pressure, requirements to withstand high temperatures and/or pressures are eliminated. Important for the capital costs of equipment are membrane and module costs. For the same reason, operation and maintenance of the equipment is limited as long as costs for heating and cooling are low and membrane lifetime is long. Further characteristics are:

- 100 % (theoretical) rejection of ions, macromolecules, colloids, bacteria, virus and other non-volatiles
- Lower operating temperatures than conventional distillation
- Lower operating pressure than membrane separation processes (reverse osmosis)
- Low sensitivity to variations in many process variables (e.g. pH and salts)
- Good to excellent mechanical properties and chemical resistance
- Reduced use of chemicals, filters and other consumables
- Self-regulating process
- Waste heat sources with temperatures below 100 °C can be used as the driving force in the process

But it should also be recognized that the process has certain drawbacks:

- Considerable energy intensity, e.g. higher than for reverse osmosis but large part of the energy is needed as heat needed, and can be waste heat
- Volatiles cannot be completely separated unless e.g. degassing equipment is added
- Sensitivity to surfactants
- There are 2 liquid product streams, i.e. no solid product, which can be an advantage if both can be reused.

6.2 Process configurations

Four basic configurations have been developed

- *Direct Contact Membrane Distillation (DCMD)* – the liquid that evaporates on one side of the membrane condenses into a cooling stream on the other side of the membrane
- *Air Gap Membrane Distillation (AGMD)* – the vapor goes through the membrane into an air-gap and is condensed on the other side of the gap.
- *Vacuum Membrane Distillation (VMD)* – a vacuum is created in the air gap to increase flux over the membrane
- *Sweeping Gas Membrane Distillation (SGMD)* – the vapor is swept away by a gas flow after passing the membrane and condenses in a condenser.

6.3 Costs

Costs for treatment of water with membrane distillation will vary depending on the application.

Specific costs to take into account are:

- Infrastructure costs (area for membrane distillation unit, housing if necessary, supply of power, water, heat and cooling)
- Equipment costs
 - Pre-treatment (e.g. filter for particles, possible pH adjustment)

- Membranes (needed membrane area based on membrane performance) and modules
 - Pumps, piping, process control etc.
 - Heat exchangers
- Running costs
 - Costs for electricity
 - Costs for heat
 - Costs for cooling
 - New membranes (life-time of some years, depending on specific application)
 - Possible costs for by-products
 - Consumables (filters, etc.), possibly water costs
- Costs for capital recovery

As an example it can be mentioned that the investment costs for the pilot equipment in this project has been roughly 2 MSEK for a system with 10 modules. Costs for full scale implementations will be different depending on the application and the prerequisites.

As heat might be an important cost factor, additional heat exchangers for heat recovery can be an option.

6.4 Applications

Membrane distillation has been tested for a number of different applications. As the technology is comparably new, there is no typical main application yet.

Some applications that have been investigated due to the characteristics of membrane distillation are (Khayet and Matsuura, 2011):

- Production of drinking water by desalination
- Production of ultrapure water, e.g. in the semiconductor industry
- Treatment of concentrated brine streams in industry
- Recovery of flue gas condensate
- Separation of pharmaceuticals from wastewater streams
- Ammonia removal

7 Annex 2: Analysis of pharmaceuticals

7.1 Pharma 1

Concentration in permeate water (ng/l). Less than (<) means below detection limit.

Substance:	Feed	Mod.5a, 57C	Mod. 5a, 73C	Mod. 5b, 58C	Mod. 5b, 74C
Diclofenac	441	<3	<3	<3	<3
Enalapril	<15	<7	<7	<7	<7
Ethinylestradiol	<100	<25	<25	<25	<25
Furosemide	613	<5	<5	<5	<5
Sulfamethoxazole	91	<7	<7	<7	<7
Hydrochlorothiazide	1155	<3	<3	<3	<3
Ibuprofen	58	<3	<3	<3	<3
Naproxen	76	<5	<5	<5	<5
Estradiol	<100	<30	<30	<30	<30
Estriol	<57	<10	<10	<10	<10
Estrone	<50	<10	<10	<10	<10
Warfarin	12	<2	<2	<2	<2
Ramipril	<10	<6	<6	<6	<6
Norfloxacin	<50	<20	<20	<20	<20
Caffeine	<71	<3	<3	<3	<3
Atenolol	147	<1	<1	<1	<1
Ciprofloxacin	22	<10	<10	<10	<10
Paracetamol	22	<8	<8	<8	<8
Terbutaline	13	<10	<10	<10	<10
Trimetoprim	31	<3	<3	<3	<3
Ranitidine	88	<5	<5	<5	<5
Metoprolol	963	<1	<1	<1	<1
Oxazepam	282	<2	<2	<2	<2
Carbamazepine	256	<1	<1	<1	<1
Ketoprofen	101	<4	<4	<4	<4
Finasteride	<9	<3	<3	<3	<3
Amlodipine	24	<8	<8	<8	<8
Propranolol	53	<2	<2	<2	<2
Citalopram	146	<2	<2	<2	<2
Norethindrone	<70	<10	<10	<10	<10
Bisoprolol	35	<3	<3	<3	<3
Progesterone	<63	<15	<15	<15	<15
Simvastatin	<20	<20	<20	<20	<20
Sertraline	<11	2.1	4.6	1.1	2.7
Ketoconazole	<28	<10	<10	<10	<10
Tetracycline	<31	<10	<10	<10	<10
Doxycycline	<138	<40	<40	<40	<40

**less than (<) means below detection limit*

7.2 Pharma 2

Concentration in permeate water (ng/l). Less than (<) means below detection limit.

Substance:	Log K_{ow}:	Waste-water	Half volume	Final conc.	Perm. half 4a	Perm. end 4a	Perm. start	Perm. end 5a
Diclofenac	4.06	481	496	795	<3	<3	<3	<3
Enalapril	2.43	<7	<7	<7	<2	<2	<2	<2
Ethinylestradiol	4.52	<100	<100	<100	<18	<18	<18	<18
Furosemide	3.00	966	780	1683	<6	<6	<6	<6
Sulfamethoxazole	0.90	164	185	284	<1	<1	<1	<1
Hydrochlorothiazide	-0.07	612	124	115	<2	<2	<2	<2
Ibuprofen	3.72	112	130	52	<2	<2	<2	<2
Naproxen	3.00	66	50	82	<3	<3	<3	<3
Estradiol	4.13	<100	<100	<100	<21	<21	<21	<21
Estriol	2.50	<62	<62	<62	<15	<15	<15	<15
Estrone	3.10	<50	<50	<50	<10	<10	<10	<10
Warfarin	2.70	0	0	0	<2	<2	<2	<2
Ramipril	1.40	<10	<10	<10	<5	<5	<5	<5
Norfloxacin	-1.00	<50	<50	<50	<8	<8	<8	<8
Caffeine	-0.13	190	424	1413	<7	<7	<7	<7
Atenolol	0.10	515	740	2540	<2	<2	<2	<2
Ciprofloxacin	0.28	73	121	633	<8	<8	<8	<8
Paracetamol	0.34	66	77	218	<3	<3	<3	<3
Terbutaline	0.48	15	<10	<10	<5	<5	<5	<5
Trimetoprim	0.90	137	201	648	<2	<2	<2	<2
Ranitidine	1.23	286	260	1405	<6	<6	<6	<6
Metoprolol	1.79	3403	4861	13787	1.4	4.4	<1	2.4
Oxazepam	2.31	124	56	75	<1	<1	<1	<1
Carbamazepine	2.67	562	702	1644	<1	<1	<1	<1
Ketoprofen	2.81	68	29	136	<4	<4	<4	<4
Finasteride	3.00	<8	<8	<8	<1	<1	<1	<1
Amlodipine	3.00	<15	<15	<15	<3	<3	<3	<3
Propranolol	3.10	174	198	374	<2	<2	<2	<2
Citalopram	3.20	439	513	692	1.7	3.2	<1	2.1
Norethindrone	3.38	<75	<75	<75	<8	<8	<8	<8
Bisoprolol	4.00	114	152	405	<2	<2	<2	<2
Progesterone	4.04	<58	<58	<58	<10	<10	<10	<10
Simvastatin	4.70	<25	<25	<25	<20	<20	<20	<20
Sertraline	5.06	8.7	<7	<7	<3	<3	<3	<3
Ketoconazole	4.35	<30	<30	<30	<10	<10	<10	<10
Tetracycline	-1.50	33	<25	<25	<7	<7	<7	<7
Doxycycline	0.00	<98	<98	<98	<21	<21	<21	<21

7.3 Pharma 3

Concentration in permeate water (ng/l). Less than (<) means below detection limit.

7.3.1 First run

Modules 1-5 and first=a, second=b, at start of the test.

Substance:	Concentrations 17 th of June										
	Tank	1a	1b	2a	2b	3a	3b	4a	4b	5a	5b
Diclofenac	271	<25	<25	<25	<25	<25	<25	<25	<25	<25	<25
Enalapril	<50	<50	<50	<50	<50	<50	<50	<50	<50	<50	<50
Ethinylestradiol	<200	<200	<200	<200	<200	<200	<200	<200	<200	<200	<200
Furosemide	1040	<100	<100	<100	<100	<100	<100	<100	<100	<100	<100
Sulfamethoxazole	<50	<15	<15	<15	<15	<15	<15	<15	<15	<15	<15
Hydrochlorothiazide	559	<25	<25	<25	<25	<25	<25	<25	<25	<25	<25
Ibuprofen	115	<40	<40	<40	<40	<40	<40	<40	<40	<40	<40
Naproxen	133	<80	<80	<80	<80	<80	<80	<80	<80	<80	<80
Estradiol	<200	<100	<100	<100	<100	<100	<100	<100	<100	<100	<100
Estriol	<150	<100	<100	<100	<100	<100	<100	<100	<100	<100	<100
Estrone	<150	<50	<50	<50	<50	<50	<50	<50	<50	<50	<50
Warfarin	<10	<4	<4	<4	<4	<4	<4	<4	<4	<4	<4
Ramipril	<100	<50	<50	<50	<50	<50	<50	<50	<50	<50	<50
Norfloxacin	118	<25	<25	<25	<25	<25	<25	<25	<25	<25	<25
Caffeine	119	<20	<20	<20	<20	<20	<20	<20	<20	<20	<20
Atenolol	189	<10	<10	<10	<10	<10	<10	<10	<10	<10	<10
Ciprofloxacin	158	<25	<25	<25	<25	<25	<25	<25	<25	<25	<25
Paracetamol	57	<25	<25	<25	<25	<25	<25	<25	<25	<25	<25
Terbutaline	<30	<25	<25	<25	<25	<25	<25	<25	<25	<25	<25
Trimetoprim	73	<10	<10	<10	<10	<10	<10	<10	<10	<10	<10
Ranitidine	490	<10	<10	<10	<10	<10	<10	<10	<10	<10	<10
Metoprolol	1330	<5	<5	<5	<5	<5	<5	<5	<5	<5	<5
Oxazepam	283	<5	<5	<5	<5	<5	<5	<5	<5	<5	<5
Carbamazepine	299	<15	<15	<15	<15	<15	<15	<15	<15	<15	<15
Ketoprofen	96	<20	<20	<20	<20	<20	<20	<20	<20	<20	<20
Finasteride	<40	<20	<20	<20	<20	<20	<20	<20	<20	<20	<20
Amlodipine	<200	<100	<100	<100	<100	<100	<100	<100	<100	<100	<100
Propranolol	95	<3	<3	<3	<3	<3	<3	<3	<3	<3	<3
Citalopram	292	<3	<3	<3	<3	<3	<3	<3	<3	<3	<3
Norethindrone	<150	<50	<50	<50	<50	<50	<50	<50	<50	<50	<50
Bisoprolol	<50	<10	<10	<10	<10	<10	<10	<10	<10	<10	<10
Progesterone	<300	<100	<100	<100	<100	<100	<100	<100	<100	<100	<100
Simvastatin	<100	<50	<50	<50	<50	<50	<50	<50	<50	<50	<50
Sertraline	43	1.7	2.4	1.4	<1	2.9	2.7	4.2	9.3	7.8	12
Ketoconazole	172	<20	<20	<20	<20	<20	<20	<20	<20	<20	<20
Tetracycline	<50	<25	<25	<25	<25	<25	<25	<25	<25	<25	<25
Doxycycline	<120	<75	<75	<75	<75	<75	<75	<75	<75	<75	<75

7.3.2 Second run

At end of the test. Concentration in permeate water (ng/l). Less than (<) means below detection limit.

Substance:	Tank	1a	1b	2a	2b	3a	3b	4a	4b	5a	5b
Diclofenac	426	<25	<25	<25	<25	<25	<25	<25	<25	<25	<25
Enalapril	<50	<50	<50	<50	<50	<50	<50	<50	<50	<50	<50
Ethinylestradiol	<200	<200	<200	<200	<200	<200	<200	<200	<200	<200	<200
Furosemeide	1450	<100	<100	<100	<100	<100	<100	<100	<100	<100	<100
Sulfamethoxazole	131	<15	<15	<15	<15	<15	<15	<15	<15	<15	<15
Hydrochlorothiazide	461	<25	<25	<25	<25	<25	<25	<25	<25	<25	<25
Ibuprofen	196	<40	<40	<40	<40	<40	<40	<40	<40	<40	<40
Naproxen	148	<80	<80	<80	<80	<80	<80	<80	<80	<80	<80
Estradiol	<200	<100	<100	<100	<100	<100	<100	<100	<100	<100	<100
Estriol	<150	<100	<100	<100	<100	<100	<100	<100	<100	<100	<100
Estrone	<150	<50	<50	<50	<50	<50	<50	<50	<50	<50	<50
Warfarin	<10	<4	<4	<4	<4	<4	<4	<4	<4	<4	<4
Ramipril	<100	<50	<50	<50	<50	<50	<50	<50	<50	<50	<50
Norfloracin	309	<25	<25	<25	<25	<25	<25	<25	<25	<25	<25
Caffeine	262	25	<20	<20	<20	<20	<20	127	<20	<20	<20
Atenolol	329	<10	<10	<10	<10	<10	<10	<10	<10	<10	<10
Ciprofloxacin	335	<25	<25	<25	<25	<25	<25	<25	<25	<25	<25
Paracetamol	81	<25	<25	<25	<25	<25	<25	<25	<25	<25	<25
Terbutaline	<30	<25	<25	<25	<25	<25	<25	<25	<25	<25	<25
Trimetoprim	131	<10	<10	<10	<10	<10	<10	<10	<10	<10	<10
Ranitidine	825	<10	<10	<10	<10	<10	<10	<10	<10	<10	<10
Metoprolol	2280	<5	<5	<5	<5	<5	<5	<5	<5	<5	<5
Oxazepam	356	<5	<5	<5	<5	<5	<5	<5	<5	<5	<5
Carbamazepine	512	<15	<15	<15	<15	<15	<15	<15	<15	<15	<15
Ketoprofen	137	<20	<20	<20	<20	<20	<20	<20	<20	<20	<20
Finasteride	<40	<20	<20	<20	<20	<20	<20	<20	<20	<20	<20
Amlodipine	<200	<100	<100	<100	<100	<100	<100	<100	<100	<100	<100
Propranolol	137	<3	<3	<3	<3	<3	<3	<3	<3	<3	<3
Citalopram	202	<3	<3	<3	<3	<3	<3	<3	<3	<3	<3
Norethindrone	<150	<50	<50	<50	<50	<50	<50	<50	<50	<50	<50
Bisoprolol	69	<10	<10	<10	<10	<10	<10	<10	<10	<10	<10
Progesterone	<300	<100	<100	<100	<100	<100	<100	<100	<100	<100	<100
Simvastatin	<100	<50	<50	<50	<50	<50	<50	<50	<50	<50	<50
Sertraline	13	<1	<1	<1	<1	1.2	<1	<1	<1	<1	<1
Ketoconazole	98	<20	<20	<20	<20	<20	<20	<20	<20	<20	<20
Tetracycline	<50	<25	<25	<25	<25	<25	<25	<25	<25	<25	<25
Doxycycline	<120	<75	<75	<75	<75	<75	<75	<75	<75	<75	<75

7.3.3 Third run

At end of the test. Concentration in permeate water (ng/l). Less than (<) means below detection limit.

Substance:	Tank	1a	1b	2a	2b	3a	3b	4a	4b	5a	5b
Diclofenac	1100	<25	<25	<25	<25	<25	<25	<25	<25	<25	<25
Enalapril	<50	<50	<50	<50	<50	<50	<50	<50	<50	<50	<50
Ethinylestradiol	770	<200	<200	<200	<200	<200	<200	<200	<200	<200	<200
Furosemide	5100	<100	<100	<100	<100	<100	<100	<100	<100	<100	<100
Sulfamethoxazole	360	<15	<15	<15	<15	<15	<15	<15	<15	<15	<15
Hydrochlorothiazide	1200	<25	<25	<25	<25	<25	<25	<25	<25	<25	<25
Ibuprofen	480	<40	<40	<40	<40	<40	<40	<40	<40	<40	<40
Naproxen	190	<80	<80	<80	<80	<80	<80	<80	<80	<80	<80
Estradiol	1600	<100	<100	<100	<100	<100	<100	<100	<100	<100	<100
Estriol	280	<100	<100	<100	<100	<100	<100	<100	<100	<100	<100
Estrone	<150	<50	<50	<50	<50	<50	<50	<50	<50	<50	<50
Warfarin	21	<4	<4	<4	<4	<4	<4	<4	<4	<4	<4
Ramipril	<100	<50	<50	<50	<50	<50	<50	<50	<50	<50	<50
Norfloxacin	530	<25	<25	<25	<25	<25	<25	<25	<25	<25	<25
Caffeine	640	<20	<20	<20	<20	<20	<20	<20	<20	<20	<20
Atenolol	1300	<10	<10	<10	<10	<10	<10	<10	<10	<10	<10
Ciprofloxacin	2000	<25	<25	<25	<25	<25	<25	<25	<25	<25	<25
Paracetamol	320	<25	<25	<25	<25	<25	<25	<25	<25	<25	<25
Terbutaline	<30	<25	<25	<25	<25	<25	<25	<25	<25	<25	<25
Trimetoprim	330	<10	<10	<10	<10	<10	<10	<10	<10	<10	<10
Ranitidine	2500	<10	<10	<10	<10	<10	<10	<10	<10	<10	<10
Metoprolol	7200	<5	<5	<5	<5	<5	<5	<5	<5	<5	<5
Oxazepam	870	<5	<5	<5	<5	<5	<5	<5	<5	<5	<5
Carbamazepine	1600	<15	<15	<15	<15	<15	<15	<15	<15	<15	<15
Ketoprofen	290	<20	<20	<20	<20	<20	<20	<20	<20	<20	<20
Finasteride	<40	<20	<20	<20	<20	<20	<20	<20	<20	<20	<20
Amlodipine	<200	<100	<100	<100	<100	<100	<100	<100	<100	<100	<100
Propranolol	340	<3	<3	<3	<3	<3	<3	<3	<3	<3	<3
Citalopram	700	<3	<3	<3	<3	<3	<3	<3	<3	<3	<3
Norethindrone	<150	<50	<50	<50	<50	<50	<50	<50	<50	<50	<50
Bisoprolol	200	<10	<10	<10	<10	<10	<10	<10	<10	<10	<10
Progesterone	<300	<100	<100	<100	<100	<100	<100	<100	<100	<100	<100
Simvastatin	<100	<50	<50	<50	<50	<50	<50	<50	<50	<50	<50
Sertraline	4.3	5.9	4.2	5.2	6.3	7.3	3.4	6.7	4.5	6.5	3.2
Ketoconazole	<50	<20	<20	<20	<20	<20	<20	<20	<20	<20	<20
Tetracycline	84	<25	<25	<25	<25	<25	<25	<25	<25	<25	<25
Doxycycline	<120	<75	<75	<75	<75	<75	<75	<75	<75	<75	<75

7.3.4 Fourth run

At end. Concentration in permeate water (ng/l). Less than (<) means below detection limit.

Substance:	Tank	1a	1b	2a	2b	3a	3b	4a	4b	5a	5b
Diclofenac	2600	<25	<25	<25	<25	<25	<25	<25	<25	<25	<25
Enalapril	<50	<50	<50	<50	<50	<50	<50	<50	<50	<50	<50
Ethinylestradiol	2000	<200	<200	<200	<200	<200	<200	<200	<200	<200	<200
Furosemide	10000	<100	<100	<100	<100	<100	<100	<100	<100	<100	<100
Sulfamethoxazole	840	<15	<15	<15	<15	<15	<15	<15	<15	<15	<15
Hydrochlorothiazide	3200	<25	<25	<25	<25	<25	<25	<25	<25	<25	<25
Ibuprofen	980	<40	<40	<40	<40	<40	<40	<40	<40	<40	<40
Naproxen	210	<80	<80	<80	<80	<80	<80	<80	<80	<80	<80
Estradiol	5500	<100	<100	<100	<100	<100	<100	<100	<100	<100	<100
Estriol	510	<100	<100	<100	<100	<100	<100	<100	<100	<100	<100
Estrone	<150	<50	<50	<50	<50	<50	<50	<50	<50	<50	<50
Warfarin	49	<4	<4	<4	<4	<4	<4	<4	<4	<4	<4
Ramipril	<100	<50	<50	<50	<50	<50	<50	<50	<50	<50	<50
Norfloxacin	1200	<25	<25	<25	<25	<25	<25	<25	<25	<25	<25
Caffeine	1500	<20	<20	<20	<20	<20	<20	<20	<20	<20	<20
Atenolol	3600	<10	<10	<10	<10	<10	<10	<10	<10	<10	<10
Ciprofloxacin	3800	<25	<25	<25	<25	<25	<25	<25	<25	<25	<25
Paracetamol	1400	<25	<25	<25	<25	<25	<25	<25	<25	<25	<25
Terbutaline	99	<25	<25	<25	<25	<25	<25	<25	<25	<25	<25
Trimetoprim	770	<10	<10	<10	<10	<10	<10	<10	<10	<10	<10
Ranitidine	7200	<10	<10	<10	<10	<10	<10	<10	<10	<10	<10
Metoprolol	20000	<5	<5	<5	<5	<5	<5	<5	<5	<5	<5
Oxazepam	2300	<5	<5	<5	<5	<5	<5	<5	<5	<5	<5
Carbamazepine	4300	<15	<15	<15	<15	<15	<15	<15	<15	<15	<15
Ketoprofen	790	<20	<20	<20	<20	<20	<20	<20	<20	<20	<20
Finasteride	<40	<20	<20	<20	<20	<20	<20	<20	<20	<20	<20
Amlodipine	<200	<100	<100	<100	<100	<100	<100	<100	<100	<100	<100
Propranolol	810	<3	<3	<3	<3	<3	<3	<3	<3	<3	<3
Citalopram	1400	<3	<3	<3	<3	<3	<3	<3	<3	<3	<3
Norethindrone	<150	<50	<50	<50	<50	<50	<50	<50	<50	<50	<50
Bisoprolol	550	<10	<10	<10	<10	<10	<10	<10	<10	<10	<10
Progesterone	<300	<100	<100	<100	<100	<100	<100	<100	<100	<100	<100
Simvastatin	<100	<50	<50	<50	<50	<50	<50	<50	<50	<50	<50
Sertraline	10	5.9	5.4	5.7	8.7	9.4	5.6	7.6	5.6	6.7	6.6
Ketoconazole	99	<20	<20	<20	<20	<20	<20	<20	<20	<20	<20
Tetracycline	180	<25	<25	<25	<25	<25	<25	<25	<25	<25	<25
Doxycycline	<120	<75	<75	<75	<75	<75	<75	<75	<75	<75	<75



IVL Swedish Environmental Research Institute Ltd., P.O. Box 210 60,
S-100 31 Stockholm, Sweden
Phone: +46-8-598 563 00 Fax: +46-8-598 563 90
www.ivl.se