

Industrial Ventilated Electric Ovens

with air exchange - suitable for heat treatments up to 260 °C

OVEN TYPE

CDTM

HIGHLY VERSATILE Industrial Electric Ventilated Ovens, suitable for a variety of heat treatments, even complex ones.

Floor-level access for trolleys, baskets, containers, cages, etc.

Main features:

- Precision and uniformity of temperature
- Layered ventilation for optimum distribution and homogenization of working temperature.
- Innovative air exchange system, adjustable to optimise smoke , vapour or substance emissions released during the heating processes, optional programmable device with forced air exchange for particularly smoky processes.
- High degree of insulation and thermal cutout
- Robust, leak-proof stainless steel chamber
- Basic materials and components of the highest quality, from Italian sources where possible
- Easy-to-use electronic digital thermoregulator with self-diagnostics.
- Innovative safety system that automatically intervenes to stop the oven in case of the set temperature is accidentally exceeded.
- Wide range of accessories available on request
- Ovens range from 600 to 20,000 litres of inner chamber

EXCELLENT VALUE FOR MONEY

Distributor:

PU Consulting AB

info@puconsulting.se

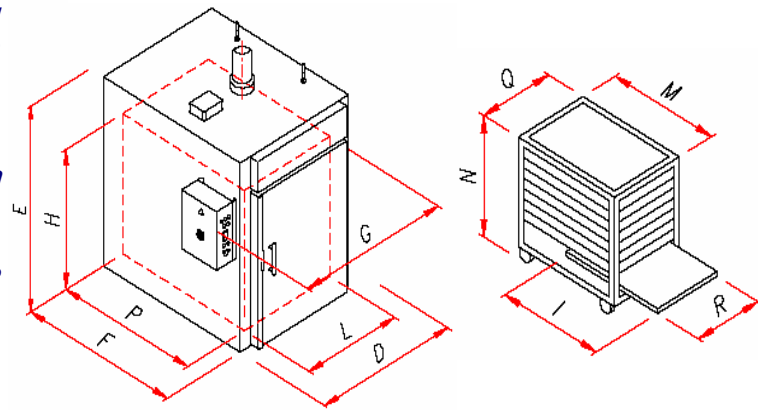

MODEL		CDTM 600	CDTM 1000	CDTM 1500	CDTM 2000	CDTM 3000	CDTM 4000	CDTM 7000
Chamber capacity	[Litres]	640	1000	1750	2200	3240	4300	7500
Operation temperature	[°C]	240 (max 260)	240 (max 260)	240 (max 260)	240 (max 260)	240 (max 260)	240 (max 260)	240 (max 260)
Electric resistors power	[kW]	11,2	11,2	16,5	16,5	22,5	33	44
Air homogenizing fan	[kW]	0,75	1,1	1,1	1,1	1,1 + 1,1	2,2+2,2	5,5+5,5
Air exchange conduct (diameter)	[mm]	33	33	33	33	33	45	45+45
Air exchange fan (optional)	[kW]	0,18	0,18	0,18	0,18	0,18	0,18	0,25+0,25
Inner chamber dimensions	L [mm]	800	1000	1000	1000	1000	1200	1800
	H [mm]	1000	1000	1200	1500	1800	1800	2000
	P [mm]	800	1000	1460	1460	1800	2000	2100
	D [mm]	1160	1350	1350	1350	1400	1600	2400
Overall dimensions	E [mm]	1750	1800	2000	2300	2600	2700	3000
	F [mm]	1350	1600	2000	2000	2400	2750	2900
	G [mm]	1500	1700	1700	1700	1750	1950	2750
	Q [mm]	700	900	900	900	900	1100	1600
Carriage dimensions (optional)	M [mm]	750	950	1400	1400	1700	1900	2000
	N [mm]	970	970	1170	1470	1750	1750	1900
	R [mm]	620x750	820x950	820x1400	820x1400	820x1750	1000x1900	1500x2000
Tray dimensions (optional)	RxI [mm]	620x750	820x950	820x1400	820x1400	820x1750	1000x1900	1500x2000
Approximate weight	[Kg]	700	950	1150	1250	1600	1900	3200

SERMAC S.r.l. reserves itself the faculty to possibly apply technical or construction changes without notice