

NEXT-XPO

T3

# AFFINITY

PRODUCT BROCHURE



*Designed and Produced by*

**T3**  
SYSTEMS

T3

# AFFINITY

The ideal modular framework for all retail and exhibition displays.

It requires no tools during any stage of assembly and dismantling of displays. The system provides unrivalled modularity with the ability to reconfigure and re-purpose displays quickly and efficiently. All these unique features and benefits allow for eye catching and dynamic display solutions to be created in a fraction of the time and cost of other systems.

Its patented connector and profile design allows for multiple retro-fit accessories to be incorporated, providing even more functionality to your displays.

T3 Affinity provides unlimited design potential and keeps to our core philosophy of...

TWIST- LOCK  
CONNECT

T3  
SYSTEMS





## KEY FEATURES

- Combined easily with T3 Frame
- Range of retro fit accessories for all display requirements
- No tools required for assembly or dismantling
- Modular design for easy storage and transportation
- Reconfigurable and reusable profiles and components
- Supports many graphic types
- Worldwide distribution network



# FEATURES

## Why use T3 Affinity?

T3 Affinity is suitable for a wide variety of display environments; providing eye catching and dynamic solutions.

## Easy to Transport & Store

Designed with standard parts the entire range is modular. Large scale designs can be flat packed and stored efficiently into a range of cases. Saving on logistics and storage.

## Customizable

Our profiles are produced in either standard or custom sizes, providing complete product and solution flexibility.

## No Tools

The patented and famous twist lock assembly method means that no tools or levers are required for any display designed with T3 Affinity.

## Fast Build Times

Due to the modular design and tool free assembly, structures take a fraction of the time to build. Saving on labour costs.

## Retro Fit Accessories

Developed with a large range of retro-fit accessories including monitor supports, shelving, literature racks and more. These can all be installed on an adhoc basis to any T3 Affinity solution.

## Modular Components

The framework has been designed with modularity in mind; allowing for full displays to be reconfigured and redesigned efficiently.



## T3 **WANDLITE**

Can be used to illuminate many of your T3 Affinity structures with a range of assembly accessories.



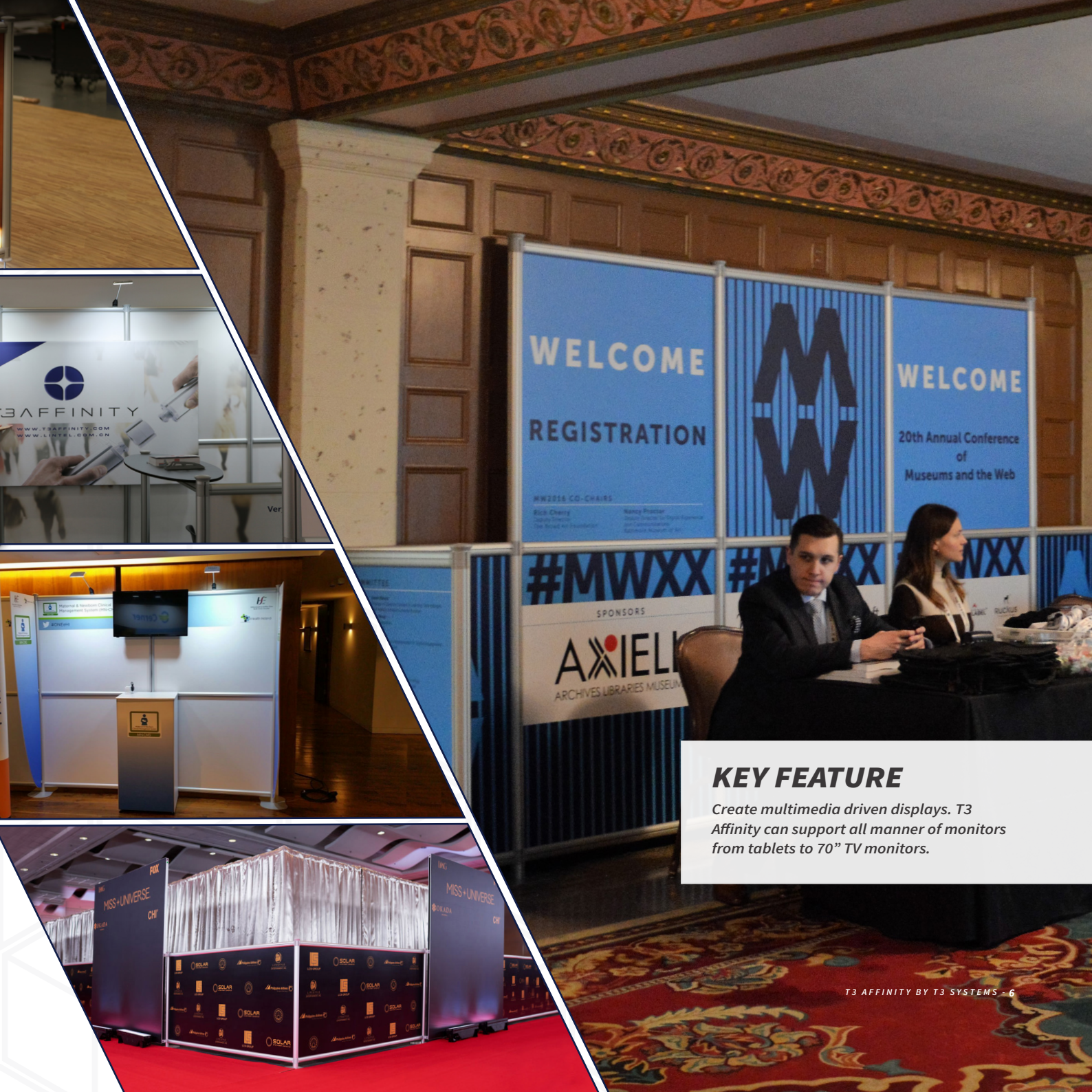

WELCOME  
REGISTRATION

WELCOME  
20th Annual Conference  
of  
Museums and the Web

MW2016 CO-CHAIRS  
Eric Cherry  
Nancy Proctor

#MWXX #MWXX #MWXX

SPONSORS

AXIEL  
ARCHIVES LIBRARIES MUSEUMS



### KEY FEATURE

Create multimedia driven displays. T3 Affinity can support all manner of monitors from tablets to 70" TV monitors.

# HOW TO

How to build a display with T3 Affinity. T3 Affinity is built quickly and easily by following these **6 simple assembly steps**.

**1.** Start by building the footprint of the stand or structure. Twist & Lock connectors into the feet or base plate. Slide the horizontal beams easily into the channels of the connectors. Once you have positioned the footprint ensure the framework is level - The height can be adjusted using the feet.

**2.** Once the footprint is levelled, twist & lock the first set of vertical posts into your base structure. Secure the next set of connectors to the ends of the posts. The rigid graphics panels then slide into place.

**3.** Slide the next set of horizontal beams into place on the connectors. The second set of vertical posts are then locked into place.

**4.** Add the final set of connectors to your vertical posts and slide your second set of rigid graphic panels into place.

**5.** Horizontal beams are then fitted into place. Twist & lock post caps into each connector to lock and complete the structure.

\*Repeat Steps 2 to 5 until desired height is achieved.

**6.** Choose from the variety of our retro fit accessories to complete your display. Accessories include shelving brackets, TV mounts, literature holders and lighting options.

1

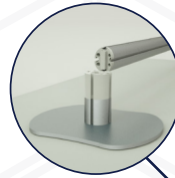

4

2

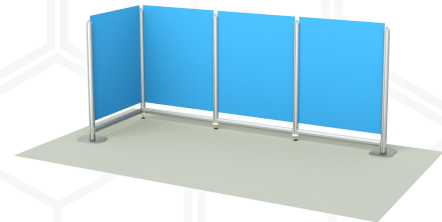

3





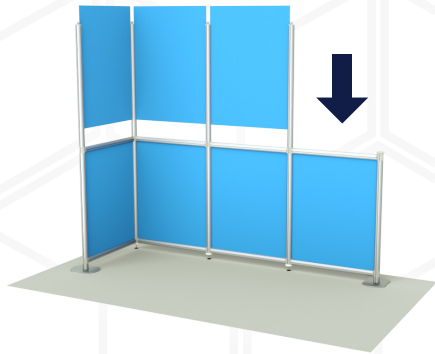

5



6

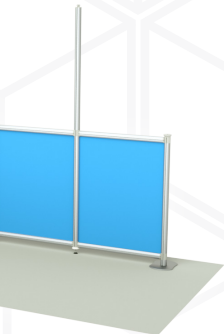

## KEY FEATURE

*T3 Affinity structures can be built to heights of 6 metres. Consult with our team for correct support and bracing configurations.*

# COMPONENTS

**Combining functionality and aesthetics has never been easier.**

The framework can be used to create all manner of displays while remaining cost effective and simple to assemble. Designers are able to include features and display accessories efficiently and without having to completely redesign their original stand.



## **Curtain Rails**

Incorporate curtain rails into your display. Ideal for creating changing rooms and private areas for your displays.



## **Slat Wall**

Adding slat wall to your design allows you to display your products easily and effectively. Multiple display hooks are available.



## **Clothing rail brackets**

In single or double configurations, it allows for clothing racks to be designed or single rails to be mounted on posts or beams.

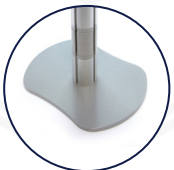

## **Supports and Feet**

T3 Affinity has multiple sizes and variations of feet and supports. These include base plates, adjustable feet; braked and unbraked wheels.





### Lighting

Illuminate your stand with our LED spotlights. Fitted with purpose built mounting clips.



### T3 Adaptor / Shell kit

Use our T3 Adaptor and shell kit clamps to create floating fabric walls on your display. Easily attached, it gives a range of graphical options.

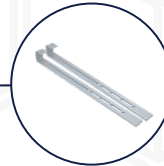

### Holders and Mounts

Boost client interaction with multimedia displays. Add tablet and tv monitors to your display with interchangeable holders.



### Display Cases

Adding clear perspex panels to your design allows you to create ideal product show cases for your retail or shop displays.



### Saddle bracket

Add custom shelving to your stand. Our various configurations of bracket mounts allow for shelving to be able quickly installed without the need for tools.

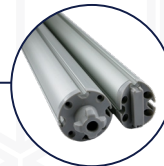

### Custom tubes

All our profiles can be cut to custom lengths allowing for complete versatility when designing your stand.

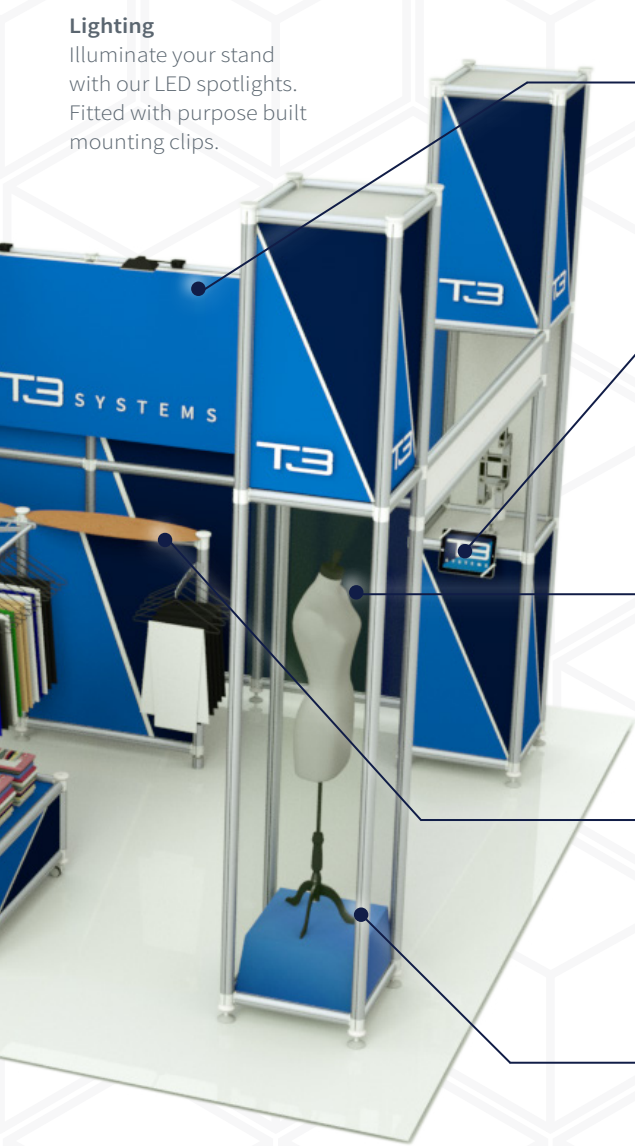

# ACCESSORIES

## Retro Fit accessories for every display requirement.

There is an extensive range of retro-fit parts and accessories designed to support every display requirement. From the application of all graphic types, shelving solutions, lighting accessories, monitor and tablet units and even an adaptability with other framework systems. The T3 Affinity system provides the utmost versatility to users while remaining simple and cost effective.

### 90° Brackets

These brackets allow for shelving units to be attached to either horizontal beams or vertical posts. Their simple installation method means that at any stage you can add shelves to your display.



### Multimedia Holders

Our range of holders are able to accommodate any sort of multimedia display. From tablets to TV monitors up to 32".



### Acrylic Shelves

These come in various sizes and configurations. Easily attached to posts and beams with a spring and bolt mechanism.



### Twist End Fitting

Allows for an Adjustable horizontal beam to be attached to posts. Ideal for adding extra accessories or support to your structure.



### Hinge

Is a flexible accessory that fits into the channel of a connector and allows for a display to be capable of being manipulated into multiple shapes and orientations.



### Brackets

These shelving brackets come in a single or double shelf orientation. Attached to posts it provides a platform for shelving to be mounted onto.







## KEY FEATURE

*Reuse your T3 Affinity profiles for multiple projects. Posts and beams can be reconfigured for other projects, providing a cost effective solution.*



## INFO

It can be used as a shell scheme framework due to its adaptability with other framework systems.

# GRAPHICS

## Finish your display with vibrant graphics

The T3 Affinity system predominantly uses rigid graphics including acrylic, foamex and dibond panels. The 4 mm panels fit into the channel of all our beams and posts. Our broad range of retro fit accessories also allow for the T3 Affinity system to use a variety of other graphic substrates and mount graphics in different manners.

**\*4.5mm Profile Width  
(Same for Beam and Posts)**

(6mm Protrusion)\*

Profiles available in stock sizes

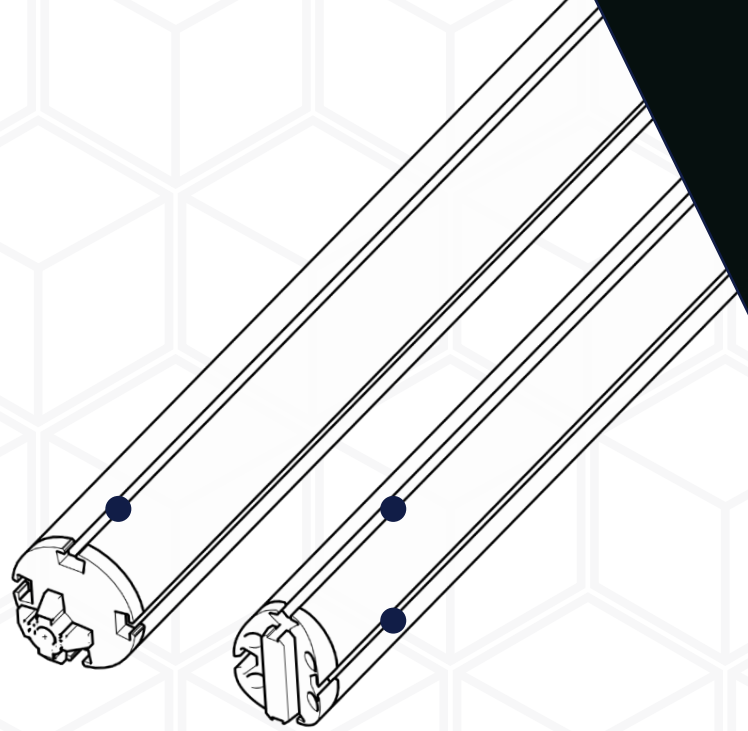

### Panel Holder

Allow for rigid panel wings or 'floating' panels to be attached to your framework. The holder fits easily into the channel of all beams and posts and secures into place using a T-bolt.

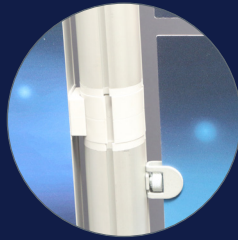

### Banner Insert

These banner inserts fit between two posts and are secured into place using a T-bolt. It allows for roll up textile graphics to be suspended in your display.

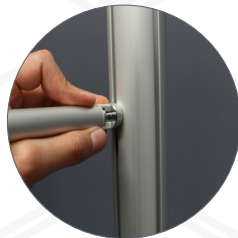

### T3 Adapter

Enables the T3 Affinity system to be combined with the T3 Frame system. This combination allows for extra flexibility with design and graphic options.



### T3 Shell Clamp

Allows for the mounting of other frameworks including T3 Frame onto T3 Affinity making use of multiple graphic options. It also enables designers to use T3 Affinity as a shell scheme framework.







## INFO

T3 Affinity has a wide variety of branded travel cases and bags to transport all your displays.



## KEY FEATURE

*Use base plates to save on space when creating display walls. In their various configurations they provide the necessary support and stability.*



# INDUSTRIES

## Developed to service every industry flawlessly.

From exhibitions to retail, T3 Affinity allows for quick and tool free installation into all venues. Its broad range of retro fit accessories gives the ability to alter stands almost immediately to fit all requirements. T3 Affinity remains a cost effective and highly versatile product. Staying true to our T3 philosophy.

### Exhibitions

This modular framework is designed for all manner of exhibition requirements. Its unique concept allows for the creation of standard structures to more elaborate designs while staying true to its a cost effective core, with a focus on simple installation, efficient storage and transport.

### Conferences

Creating large back displays is a simple and space effective process with T3 Affinity. The profiles and feet allow for the whole structure to take up a fraction of the space of other systems. The modular design means that the displays can be built in a fraction of the time by a smaller workforce, saving on costs. Also the ability to integrate the T3 Frame system allows for all manner of graphic options to be used to clad your structure.

### Retail

Designing temporary or permanent retail displays is simple with the modular twist lock assembly system. Make use of the custom profiles and multiple retro fit accessories to create purpose built shop interiors with changing rooms, featured promotional areas and slat walling for smaller products. The display can be altered quickly by simply adding more profiles and accessories. Why not create smaller shop in shop displays for limited time events.

### Point of Sale & Pop Up displays

With its patented twist lock, no tools assembly it is an ideal system for point of sale and pop up units. Which can be created in a matter of minutes and relocated to new venues simply and easily. Users can adapt their displays quickly with our wide range of retro-fit accessories. This means that a display can be used for multiple occasions and products without having to undertake a complete redesign and build.



## T3 LITEBOX

T3 Affinity can be used to add extra stability and functionality to all T3 Litebox displays.





THE  
**EMOJI  
MOVIE**  
VIRTUAL REALITY  
EXPERIENCE

EMOJI  
MOVIE

Experience  
virtual reality  
here

### **KEY FEATURE**

*The simple connection between posts, beams and connectors allows for the structures to be built in a matter of minutes.*



# NEXT-XPO

NEXT-XPO division of Next-Way 2A,  
avenue de l'artisanat B1420 Braine  
L'Alleud / Belgium

+32 2 384 83 02 ( office )



[WWW.NEXT-XPO.COM](http://WWW.NEXT-XPO.COM)

