

# SMX85



**NEW**

**CENTRAL POST  
PROFESSIONAL  
LEVERLESS  
TYRE CHANGER  
WITH "COMBI" BEAD  
BREAKING SYSTEM**

**SMONTAGOMME  
PROFESSIONALE  
AUTOCENTRANTE  
LEVERLESS CON  
SISTEMA DI  
STALLONATURA  
COMBINATA**



# CEMB

GARAGE EQUIPMENT

# SMX85



- Automatic tyre changer with pneumatic **rear tilting post** granting the maximum rigidity to prevent rim damage.
- Smontagomme automatico con **palo ribaltabile pneumaticamente** che garantisce la massima rigidità per non danneggiare il cerchio.



- **Reinforced base vertical post structure** and 60x60 mm horizontal arm grant maximum rigidity. Simultaneous vertical and horizontal arm locking system, vertical arm with spring return.
- **Struttura palo rinforzata** e braccio orizzontale avente dimensione 60x60 mm che garantisce la massima rigidità riducendo ogni possibile flessione. Sistema di bloccaggio simultaneo di asta verticale e braccio orizzontale con ritorno a molla dell'asta.



- **Wheel clamping**, fast and safe, with adjustable height centre post turntable system.
- **Bloccaggio ruota** rapido e sicuro con sistema a platorello, regolabile in altezza.

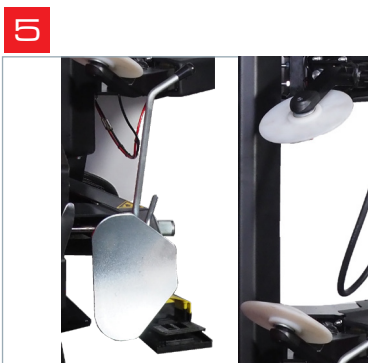

- **"Combi" bead breaking system**: with blade, for all conventional wheels and with double bead breaker arm with disc, with double movement penetration to operate on every type of UHP and Run Flat tire up to rim diameter of 30".
- **Sistema di stallonatura combinato**: a paletta, per tutte le ruote convenzionali e con doppio braccio stallonatore a dischi con penetrazione a doppio movimento per operare su ogni tipo di pneumatico UHP e Run Flat di ultima generazione, fino a un diametro massimo di 30".

- **Pedal-operated inflating device, manometer and CE-certified inflation pressure limiter.**
- **Dispositivo di gonfiaggio con azionamento a pedale, manometro e limitatore pressione di gonfiaggio a norme CE.**



## OPTIONAL ACCESSORIES

## ACCESSORI OPZIONALI



■ Additional bead-pushing device **HPX-FA** which assists during the mounting and demounting of the upper bead. It is recommended for mounting UHP and Run Flat tyres with new handle more practical, fast and ergonomic.

■ Premitallone addizionale **HPX-FA**. Aiuta in fase di montaggio e smontaggio del tallone superiore. Raccomandato per ruote UHP e Run Flat con nuova maniglia più pratica, veloce ed ergonomica.



**6** ■ Motor controlled by a double variable speed system (10-17 rpm) with motoinverter.

■ Motore controllato da un sistema a doppia velocità variabile (10-17 rpm) con motoinverter.



**7** ■ **Leverless demounting group** with double support to the rim to reduce flexions and tensions on the bead and on the rim edge. It strongly reduces the physical effort by the operator.

■ **Gruppo di smontaggio Leverless** con doppio appoggio al cerchio per ridurre le flessioni e le tensioni sul tallone e sul bordo cerchio. Riduce al minimo lo sforzo fisico da parte dell'operatore.

## STANDARD ACCESSORIES - ACCESSORI STANDARD



Protection for self centering device  
Protezione per dispositivo autocentrante



Front head protection  
Protezione frontale utensile



Rear head protection  
Protezione ala utensile

## OPTIONAL ACCESSORIES - ACCESSORI OPZIONALI



Wheel Lift  
Sollevatore

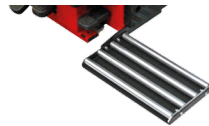

Roller board  
Kit rulliera



Tubeless inflation system  
Sistema di gonfiaggio TI



Centre closed and reversed rim flange kit  
Kit flangia per cerchi a canale rovescio e senza foro centrale



Bead breaker blade protection  
Protezione paletta



Light truck kit  
Kit per furgoni

## TECHNICAL DATA - DATI TECNICI

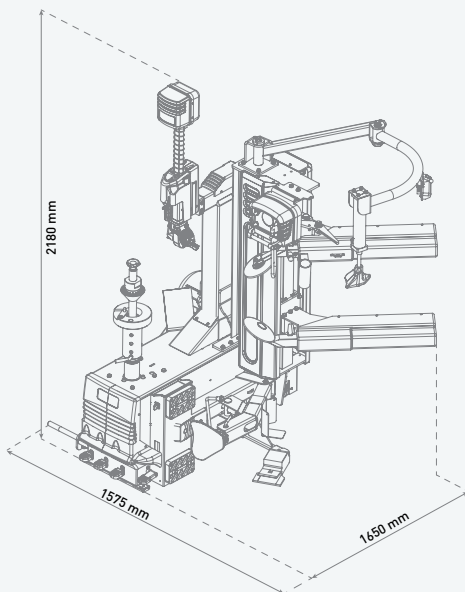

Clamping capacity	Capacità di bloccaggio	10" ÷ 30" (min ÷ max)
Internal clamping	Bloccaggio interno	12" - 30"
External clamping	Bloccaggio esterno	10" - 28"
Max wheel diameter	Diametro massimo ruota	1160 mm (46")
Max wheel width	Larghezza massima ruota	400 mm (16")
Bead breaker force	Forza stallonatore	1200 kgf (with discs) 2500 kgf (with blade)
1-Phase motor	Potenza motore monofase	1.5 kW - 230V 50-60Hz (1ph - Inverter)
Turntable speed	Velocità di rotazione	10-17 rpm (2 speed)
Operating pressure	Pressione di esercizio	8 - 12 bar (116 - 175 psi)
Noise level	Livello di rumorosità	< 70 ± 3 dB (A)
Net Weight	Peso netto	380 kg



# CEMB

BALANCING MACHINES

CEMB S.p.A.

Via Risorgimento, 9  
23826 Mandello del Lario (LC) - Italy

[www.cemb.com](http://www.cemb.com)



Garage equipment division

CEMB - ITALY

Plant and Training Center

Phone +39 0341 706111

[garage@cemb.com](mailto:garage@cemb.com)

## SIPAV

Distributore esclusivo per l'Italia:

Via A. Nobel, 21 - 42124 Sesso (RE)

Tel. 0522. 532.711 - Fax 0522.531.828

[sipav@sipav.com](mailto:sipav@sipav.com) - [www.sipav.com](http://www.sipav.com)

All the data and features mentioned in this catalogue are purely for information and do not constitute any commitment on the part of our company, which reserves the right to make any and all alterations it may consider suitable without notice.