

Small-scale mushroom cultivation - 2

Agaricus and Volvariella

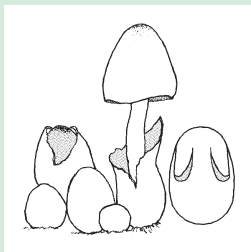

Agrodok 41

**Small-scale mushroom
cultivation - 2**

Agaricus and Volvariella

Bram van Nieuwenhuijzen

© Agromisa Foundation and CTA, Wageningen, 2007.

All rights reserved. No part of this book may be reproduced in any form, by print, photocopy, microfilm or any other means, without written permission from the publisher.

First edition: 2007

Author: Bram van Nieuwenhuijzen

Editor: Janna de Feijter

Illustrators: Bernard Lamote, Barbera Oranje

Design: Eva Kok

Translation: Rob Barnhoorn (language editing)

Printed by: Digigrafi, Wageningen, the Netherlands

ISBN Agromisa: 978-90-8573-083-5

ISBN CTA: 978-92-9081-365-1

Foreword

The first Agrodok on ‘Small-scale mushroom cultivation’, Agrodok no. 40, describes the technique of mushroom cultivation on substrates that only need heat treatment. Certain mushroom species however, like the Rice Straw Mushroom (*Volvariella* spp.) and the Button Mushroom (*Agaricus* spp.) can only be cultivated on fermented substrate or compost. Rice Straw Mushrooms are cultivated in the warmer climates of the tropical regions, whereas the growing of the Button Mushrooms predominantly takes place in more moderate climates.

The process of composting for mushroom cultivation is more complex than the preparation of temperature treated substrates. For that reason it seemed appropriate to publish a second Agrodok that meets the demand and covers the lack of information on this specific subject. It describes the complete process of composting of agricultural wastes as well as the cultivation of the appropriate species mentioned above. Moreover, it proves to be necessary to treat the process of obtaining good quality spawn and spawn production (propagation material) in detail in a separate chapter.

Special emphasis has been put on the minimum requirements for growing conditions, mushroom houses and equipment for both species in order to avoid problems and to be cost-effective.

Additionally, attention has been given to harvesting and post harvest handling. A high demand for processed (mostly canned) mushrooms does exist in suburban and urbanised regions. Consequently the basics of mushroom processing have been covered in a separate chapter. Whereas knowledge on marketing in the field of small-scale mushroom cultivation is still rather poor, it also seemed appropriate to add a chapter on marketing in which the importance and possibilities of the local and regional market(s) are pointed out.

September 2007, Bram van Nieuwenhuijzen and Janna de Feijter

Contents

1	Introduction	6
2	Biology of mushrooms	8
2.1	Fungi	8
2.2	Life cycle of fungi	9
2.3	Temperature ranges of cultivated mushrooms	12
3	Mushroom farms	13
4	Spawn production	17
4.1	Availability of spawn	17
4.2	Clean environments	19
4.3	The sterilisation process	22
4.4	Preparation of media	23
4.5	Preparation of slants	24
4.6	Cultures	26
4.7	The starter culture	26
4.8	Tissue cultures	28
4.9	Mother spawn	30
4.10	Preparation of the final spawn	33
5	Composting	35
6	Cultivation of Button Mushrooms (<i>Agaricus</i> spp.)	42
6.1	Pasteurisation or peak heating	42
6.2	Spawning	43
6.3	Casing	44
6.4	Harvesting and picking	46
6.5	Case description Button Mushrooms	47
7	Cultivation of Rice Straw Mushrooms (<i>Volvariella</i> spp.)	50
7.1	Case description Rice Straw Mushroom cultivation	54

8	Harvesting and post harvest handling	58
8.1	Harvesting	58
8.2	Fresh market	58
8.3	Preservation	59
8.4	Drying	60
9	Marketing	63
	Further reading	66
	Useful addresses	68
	Appendix 1: Formulas	72
	Appendix 2: Air quality test	73
	Appendix 3: Different origins of contamination	74
	Appendix 4: Culture transfer in detail	76
	Appendix 5: Formulas for compost	78
	Appendix 6: Simple steaming systems	80
	Glossary	82

1 Introduction

Since time immemorial people have gone into fields and woods to pick edible mushrooms. Nowadays some species of edible mushrooms can also be cultivated as cash crops.

Certain species are rather easy to grow while others demand more specific cultivation methods and temperature. In general the life cycle of a crop is rather short (varying between some weeks and a few months) When the cropping cycle has been completed the spent mushroom substrate (SMS) can be used as a soil conditioner.

Mushrooms contain a lot of proteins and minerals, several B vitamins and are regarded as a healthy food or food supplement. Moreover, due to certain chemical compounds valued for their medicinal properties, mushrooms gain more and more interest from the health food industry.

In this Agrodok information is given on the cultivation of Button Mushroom, which is consumed worldwide, and Rice Straw Mushroom, which is much valued in Asia. The specific cultivation methods of each of these mushroom species have been described in separate chapters.

Before deciding to grow either one of the species mentioned above it is wise to verify the following points:

- Check the temperature range in section 2.3 to decide whether the climate conditions are appropriate for cultivation.
- Are you able to prepare the required compost? Which kinds of agricultural wastes (and in what amounts) are available for compost preparation?
- Can mushroom spawn be purchased? If not, are you then sufficiently equipped to produce your own spawn? (See chapter 4)
- Is there a demand for mushrooms in the vicinity and in the nearby markets? (See chapter 9)

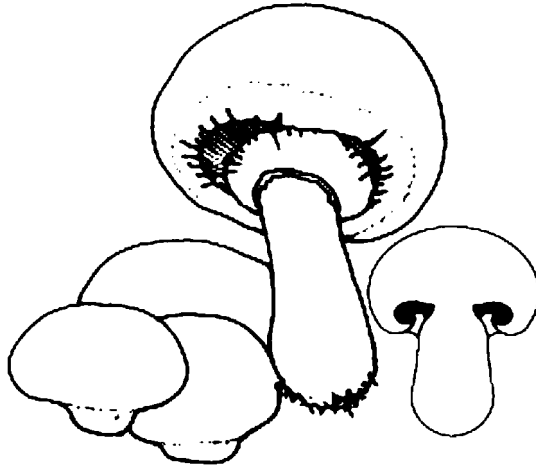

Figure 1: Button Mushroom (Agaricus spp.): closed button (left), mature (field) specimen (middle) and cross section (right)

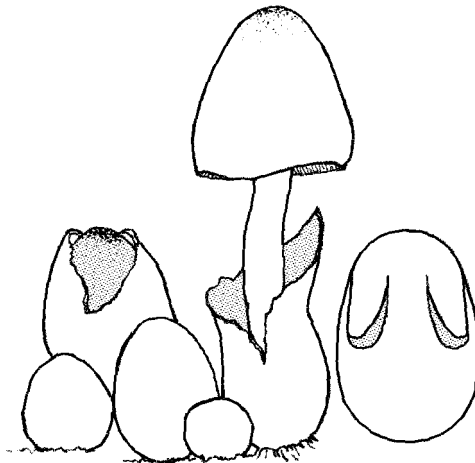

Figure 2: Rice Straw Mushroom (Volvariella spp.): egg stage (left), mature specimen (middle) and cross section (right)

2 Biology of mushrooms

2.1 Fungi

Mushrooms (Fungi) are very different from plants. Plants can use energy from the sun directly through chlorophyll. Fungi lack this ability; they depend on other organisms for food. They absorb nutrients from the organic material in which they live. The living body of the fungus is not the fruiting body above ground, but it is the mycelium that is found under ground or inside plants or wood.

The mycelium consists of a web of miniscule threads, which are called hyphae. When these hyphae are sexually compatible, the hyphae will fuse and start to form spores under specific conditions regarding temperature and moisture. The larger spore-producing structures (bigger than about 1 mm) are called mushrooms.

Scientific and colloquial names of mushrooms

The scientific names of mushrooms are often used in this Agrodok, as they give rise to less confusion than colloquial names. For example, the name Button Mushroom applies to several different species of mushroom, each with its own cultivation characteristics such as optimal temperature range, colour and growth rate.

For mushroom growers, the most practical approach to the subject of taxonomy is to rely on taxonomists. It is best to order strains from renowned spawn producers or culture collections.

Fungus ecology

Fungi depend on other organisms for their food. Three modes of living can be recognised:

- Saprophytes: such as Rice Straw Mushrooms, which degrade already dead material.
- Symbionts: living together with other organisms (especially trees) in a close, mutually beneficial relationship.
- Parasites: fungi that live at the expense of other organisms.

The mode of living has nothing to do with edibility: both edible and poisonous mushrooms can be found in all three groups. This Agrodok only deals with saprophytes.

Saprophytes

Saprophytic fungi need organic matter to decompose. In nature they will grow on fallen leaves, animal droppings, or stumps of dead wood. Some are specialised in breaking down the hairs of animals, while others may decompose birds' feathers. Saprophytes break down complex organic structures of plants and animals in order to feed on them.

2.2 Life cycle of fungi

Fungi multiply by producing spores or through mycelial growth. When a spore settles in a suitable environment, it can germinate and branch to form a mycelium. When two sexually compatible mycelia meet, they may fuse to form a secondary mycelium, which is capable of forming fruiting bodies.

Mycelial growth and spawn

In edible mushroom cultivation no use is made of spores. Their genetic characteristics may differ from those of their parents. Moreover, it takes some time for mushroom spores to germinate, whereas other fungi such as green moulds germinate and spread much faster.

The mushrooms we want to grow as a cash crop must be able to colonise the substrate before other fungi or bacteria do so. To achieve this, pre-grown mycelium (free of any contaminants) of the desired mushroom species is inoculated on a sterile substrate. This material is referred to as spawn. Using spawn will give the cultivated mushroom an advantage in growth over other fungi that have to grow from germinating spores.

Spawn run

The mycelium will colonise the compost and use the available nutrients. This is commonly referred to as spawn run. When some nutrients

run out, or when the weather changes, the mycelium will reach a different phase: the reproductive stage. A temperature of about 25° C is optimal for the spawn run of most species. The environment can also enhance the growth of the desired mycelium: a high CO₂ concentration is favourable for mycelial growth (but not for cropping).

After having colonised the substrate, the mycelium is capable of producing fruiting bodies. The number and quality of the fruiting bodies will depend on the environment.

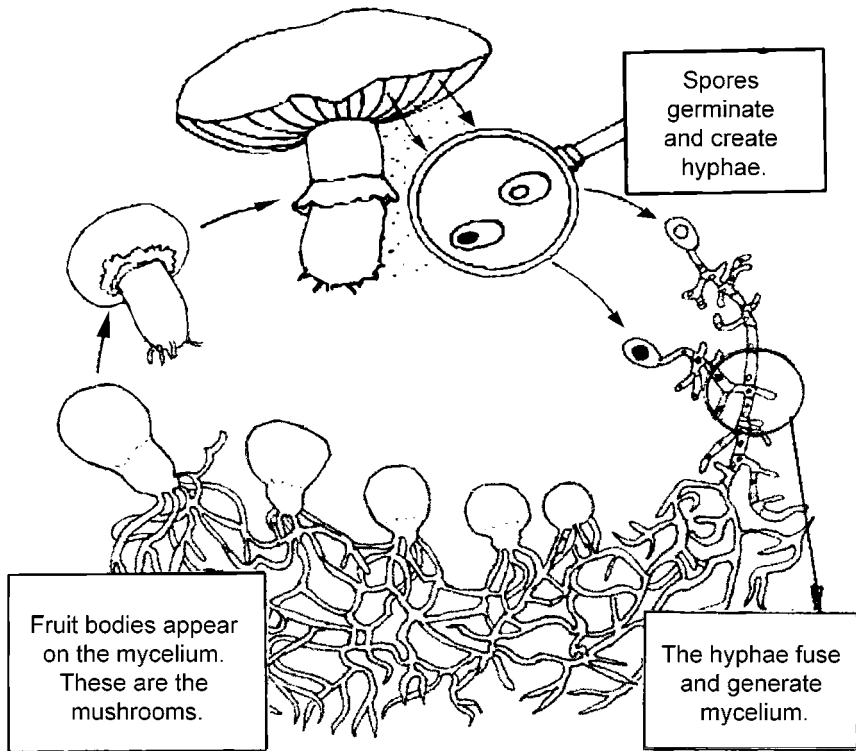

Figure 3: Life cycle of mushrooms in nature

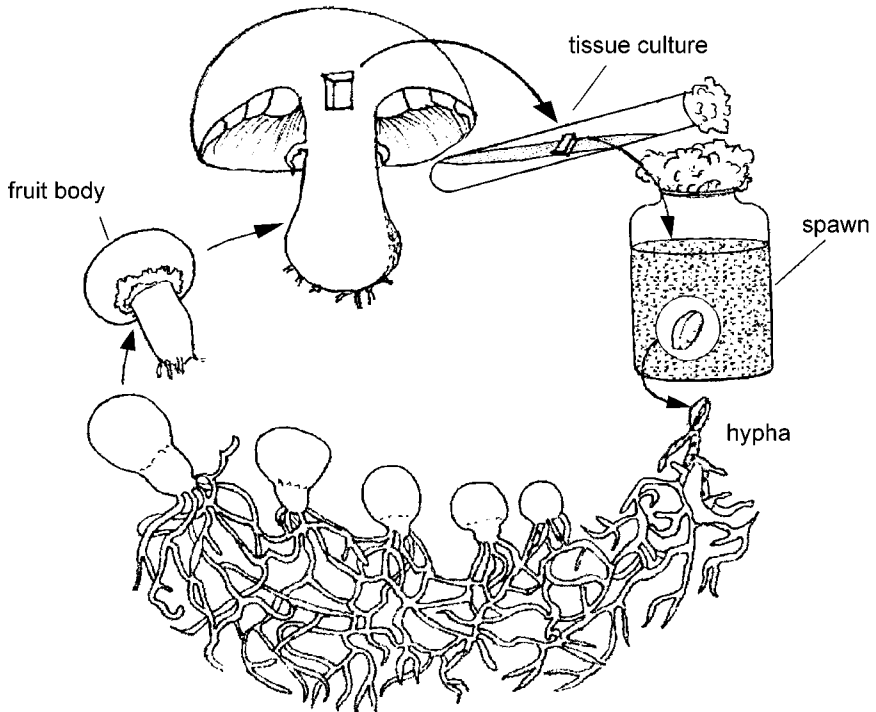

Figure 4: Life cycle of cultivated mushroom. Tissue cultures are isolated from a mushroom and propagated on a suitable substrate.

Key factors to induce fruiting bodies are:

- changing temperature
- high humidity
- deficiency of a nutrient
- CO₂ concentration in the air
- light
- physical shock

These factors differ from mushroom to mushroom. Most of the changes that stimulate fruiting have a negative effect on the vegetative growth of the mycelium. Changes should therefore only be made when the mycelium has completely grown through the substrate. It is

actually the less favourable condition for vegetative growth that will stimulate the mycelium to fruit.

Small primordia (initial fruiting bodies) will be formed at the beginning of the reproductive phase. Under the right conditions, these primordia will develop into fruiting bodies. Nutrients are transported from the mycelium to the fruiting bodies by a steady moisture flow. Water has to evaporate on the surface of the mushrooms in order to allow the flow to continue. This explains why spraying too much water on maturing mushrooms or a too high relative humidity of the air can spoil the crop.

2.3 Temperature ranges of cultivated mushrooms

Choose a species that fruits at temperatures near to your outdoor temperatures. This limits investments in climate control and reduces energy costs. As the table shows there are actually few species suited to really tropical conditions. Some mushrooms currently cultivated at temperatures around or just below 30 °C. are: *Volvariella volvacea*, and *Agaricus bitorquis* but most species prefer lower temperatures.

Table 1: Mushroom species, temperature ranges (in °C) for mycelial growth, optimal growth and fruiting, and techniques to be applied to the substrate

Mushroom species/ Common name	T _{mg}	T _{optimal mg}	T _{fruiting}	Techniques
<i>Agaricus bisporus</i>	10-32	20-28	10-20	1
<i>Agaricus bitorquis</i>	25-31	30	25-30	1
<i>Agaricus blazei</i>	n.d.	30	20-25	1
<i>Volvariella Volvacea</i>	20-40	30-35	30-32	1,2
<p>T_{mg}: The range at which the mycelium stays viable; the growth speed declines at both high and low ends of this range. T_{optimal mg}: The optimal temperature range for spawn run. T_{fruiting}: Temperature range required for fruiting. Substrate preparation techniques: 1 fermented and pasteurised substrate 2 pasteurised substrate</p>				

3 Mushroom farms

Selecting a site

When selecting a site to build a mushroom farm one has to keep in mind that following points are essential:

- availability of good quality substrate
- availability of clean water
- availability of labour
- adequate transport of the product to the market.

Farm layout

Before planning the layout it is essential to decide whether compost preparation will take place at the farm. If this is the case, keep in mind that storage of basic materials as well as the composting site itself should be located as far away as possible from the growing rooms.

It is equally important to know whether spawn will be purchased or prepared by the grower himself. In this case it is strongly advised that the spawn laboratory should not be located at the farm site at all, in order to prevent contamination spreading from one unit to another.

Temperature and ventilation

Growing rooms at a mushroom farm should provide adequate climatic conditions. In particular ventilation and temperature are essential to ensure a reasonable production. In most western countries, mushroom growers make use of mechanical climate control but this requires high financial investments and therefore will not be treated in this booklet.

To avoid high temperatures, more moderate temperature demanding mushrooms like *Agaricus* spp. are grown in caves or old tunnels. Or, the farm can be built at higher and thus cooler altitudes.

As most low-cost growing houses are constructed from bamboo, wood and plastic, a simple way of obtaining temperature reduction is by spreading wet sand on the floors underneath the shelves in the grow-

ing rooms and by wetting the bamboo-leave mats on the roof and the walls of the farmhouses.

Floors

Often, low cost growing houses are built just on bare ground. It is better to have a slightly tilted, cemented or concrete floor. These floors can be cleaned well and drain-water can flow out easily. Take good care that the drainage system of each room is not connected to another room, as diseases can spread easily through the draining pipe.

For the same reason it is wise to frequently collect waste and contaminated material and to have them destroyed immediately after collecting.

Farm hygiene

On a mushroom farm, hygiene is of vital importance. Since chemical control of pests and diseases is not feasible in small-scale mushroom cultivation, the only preventive measure is hygiene, and to some extent disinfection. This goes for a spawn production unit, the site for substrate production, the incubation rooms as well as for the production units.

Farm location

Therefore checking a suitable site for a mushroom farm is very important. The surroundings of a farm should be clean and free from possible contamination from insects, moulds etc. This means that building a new farm close to other mushroom farms should be avoided. Insects and diseases from these farms could easily spread to the new farm.

If possible separate the various operation units of the farm.

The spawn laboratory should be separate from the growing site. The growing rooms ought to be separated by closed (plastic) walls to keep the different stages of cultivation apart. As a matter of fact no incubation or spawn running should take place in the same room where the mushrooms are harvested.

Debris, contaminated bags and spent mushroom substrate must be removed immediately from the rooms and from the farm itself, preferably to a place far away.

All these measures are necessary to avoid pests such as flies and mites as well as diseases spreading from these waste dumps. If the spent mushroom substrate is to be used for gardening soil, it should be transported as soon as possible and not be stored at the mushroom farm.

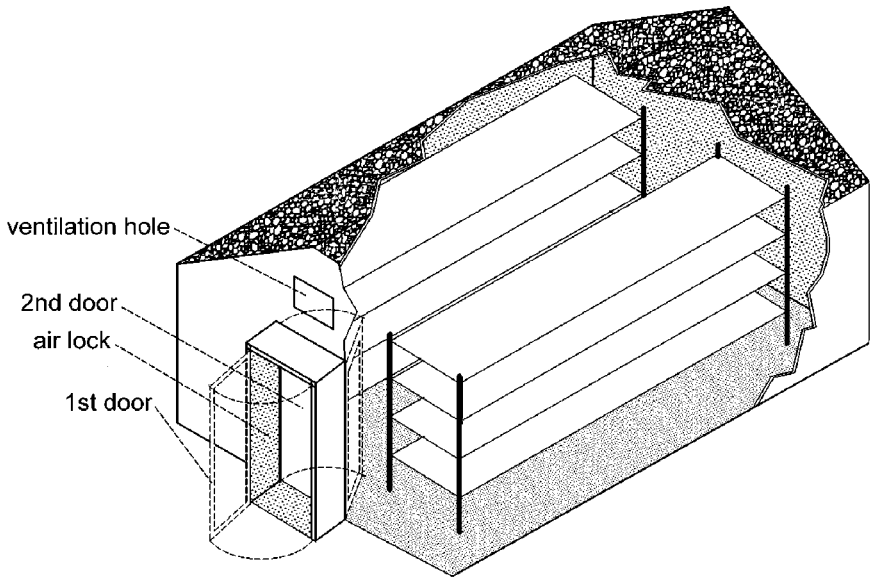

Figure 5: An example of a sophisticated farmhouse unit/growing room with air lock and racks with shelves

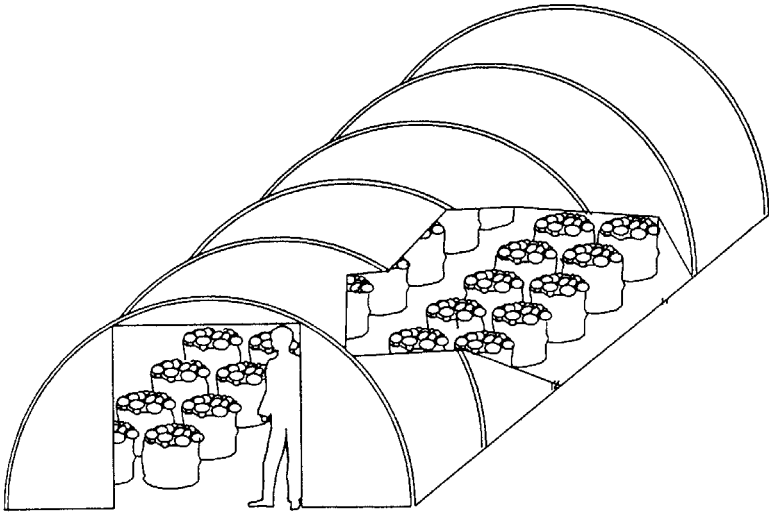

Figure 6: An example of a low-cost mushroom shed made from plastic with bags placed on the floor

4 Spawn production

The mushroom propagation material (“seed”) is generally referred to as spawn.

4.1 Availability of spawn

The availability of good quality spawn is a limiting factor for mushroom cultivation in many developing countries. Customs’ bureaucracy, high shipping costs and the difficulty to keep the spawn cooled during transport, often hinders imports. It might therefore be necessary for the mushroom grower to produce his own spawn.

If good quality spawn of the desired mushroom species can be obtained at a reasonable price, it would be wiser to concentrate on the mushroom growing process. If this is not the case, spawn will have to be produced or multiplied by the mushroom grower.

The complete procedure of spawn production involves preparation of the medium, filling the test tubes or Petri dishes and sterilising them, inoculation with mycelium and the process of inoculating larger containers with this culture

Basically, spawn production is nothing more than putting mycelium of the desired mushroom in suitable sterilised substrates under aseptic conditions.

In practice however producing spawn is not that simple. Suitable strains from the required mushroom species have to be maintained under strict conditions to avoid degeneration. If this is not possible, tissue culture from a fresh and healthy mushroom should be used for spawn production. In addition the total spawn production process requires very high standards of hygiene. It is for that reason that one has to make sure that the spawn production room is kept meticulously clean in order to avoid any contamination.



A starter culture purchased from a spawn laboratory or made from tissue culture from a fresh mushroom is transferred on agar.



Mother cultures on agar in bottles (or slants).

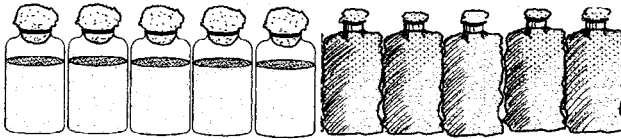

The mother cultures serve to inoculate the grain spawn cultures in bottles or bags.

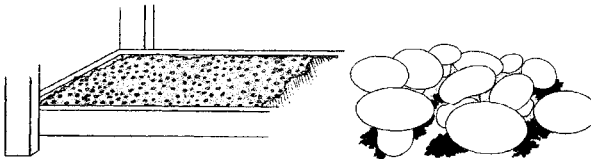

The bottles or bags finally serve to spawn the compost in the beds.

Figure 7: From tissue culture to crop - various steps in mushroom cultivation

Spawn production of *Agaricus* spp. in particular, is rather complicated. From that point of view it is highly recommendable to buy spawn from a reliable spawn producer.

Only in the case that good quality spawn is not available for a reasonable price the grower should choose to produce his own spawn.

Spawn production unit

The minimal requirements for a spawn production unit are:

- laboratory equipment such as Petri dishes, test tubes, scales, alcohol, flame
- sterilisation unit (pressure cooker, autoclave)
- sterile environment: Inoculation Box or Laminar Air Flow cabin
- incubation room

This equipment is commonly available in hospitals, research stations and universities.

The raw materials include:

- ingredients for media preparation
- pure culture or fresh mushroom of the desired mushroom species strain
- spawn containers (such as bottles or plastic bags)

In countries lacking mushroom production, spawn may be obtained from a renowned spawn producer, a university or a research station at the start of a project.

For addresses of spawn producers see Useful Addresses.

4.2 Clean environments

A clean environment is absolutely essential to spawn production. In particular whenever the containers with sterilised media need to be opened this must be done under aseptic conditions. The air carries numerous contaminants, which easily infect the sterilised media. It is therefore necessary to use special cabinets and inoculation rooms for performing the handling and the preparation of the (tissue) cultures. (For an air quality test see Appendix 2)

Inoculation rooms

The interior of the inoculation room should consist of non-biodegradable materials. All the surfaces should be smooth and easy to clean. Shelves should be designed in such a way that the floor beneath can be cleaned easily. Shelves are typically made of metal or Formica. UV light, to be switched on during non-working hours, will help to destroy contaminants.

Inoculation cabinets

These simple inoculation cabinets are widely used all over the world. They can be constructed cheaply from locally available materials. The front glass pane can be opened to fill the cabinet with the sterilised media. The inside is to be disinfected by cleaning with a 10 % Clorox solution, a 2% Formalin solution or 70% ethyl alcohol.

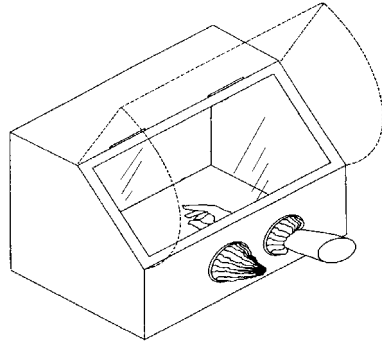

Figure 8: A simple homemade inoculation cabinet showing a front glass pane that can be opened and holes (with cloth sleeves attached) for handling purposes

Take care when using chemicals. Some of them are poisonous and/or irritating to nose and eyes. Cautiously follow the instructions to ensure safe use.

Laminar Air Flow cabinets

A Laminar Air Flow system (LAF) consists of a fan, a duct, a HEPA (High Efficiency Particle Air) filter and a hood.

In a laminar airflow contaminants can spread in only one direction. In a turbulent airflow it is possible that spores move in different directions, thus causing more contamination.

The ventilators are rated by the producers according to the volume of air they can blow through materials of specified resistance. About 0.45 m/s air velocity is considered best for good laminar airflow. The fan should be regulated stepwise and have the capacity to push double the amount of required air through the filter to reach the required air velocity, in order to account for pressure losses when the filter gets loaded with particles.

In many countries neither HEPA filters nor the specific ventilators are available and have to be imported.

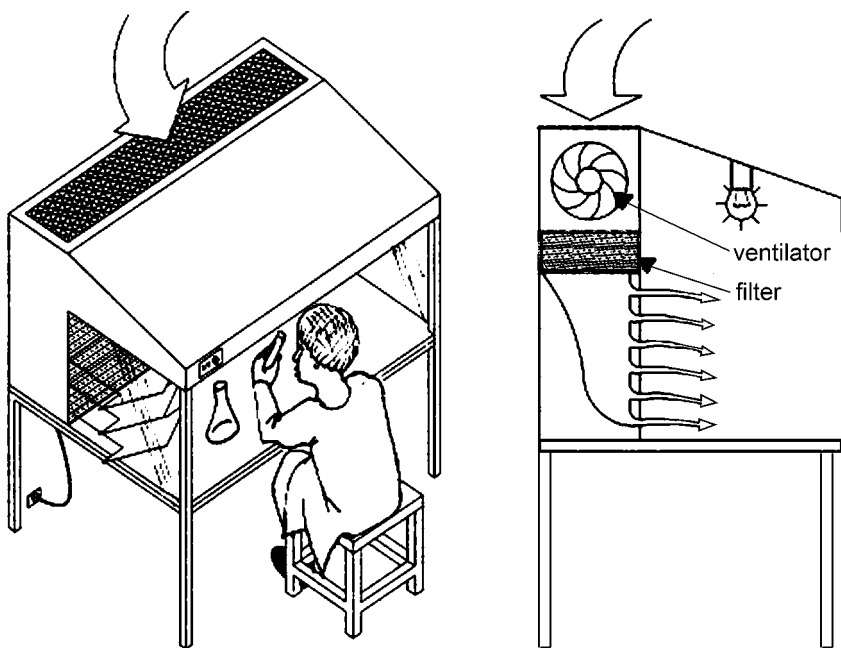

Figure 9: A Laminar Air Flow system (left) and cross section of the same LAF system (right)

So keep in mind that a good inoculation cabinet is generally better than a poorly constructed and inadequately positioned LAF system.

The filters and ventilators are the heart of any Laminar Air Flow system, but other factors have to be considered too: the operating persons, their skills and their hygiene, and the construction of the ducts and filters, to ensure that no contaminated air can be sucked in.

4.3 The sterilisation process

Grain, sawdust and compost contain large numbers of contaminants. A single grain kernel may contain millions of bacteria and fungi.

Each one of these undesired agents, which are called contaminants, is capable of spoiling substrates that have not been properly sterilised or that have greasy appearance been inoculated under unhygienic conditions.

A heat treatment of 20 minutes at 121 °C is usually sufficient to kill all organisms. It takes quite some time for the steam to heat the inner core of substrates to this temperature, depending on the way the sterilisation / pasteurisation unit is filled and on the capacity of the burner.

Pressure cookers (see figure 10)

The cheapest option is to obtain one or more large pressure cookers. Select pressure cookers that maintain the pressure when the final temperature has been reached.

The simplest pressure cookers blow out steam when the pressure is too high. The pressure inside will then often drop below 1 atmosphere overpressure, causing the media to boil.

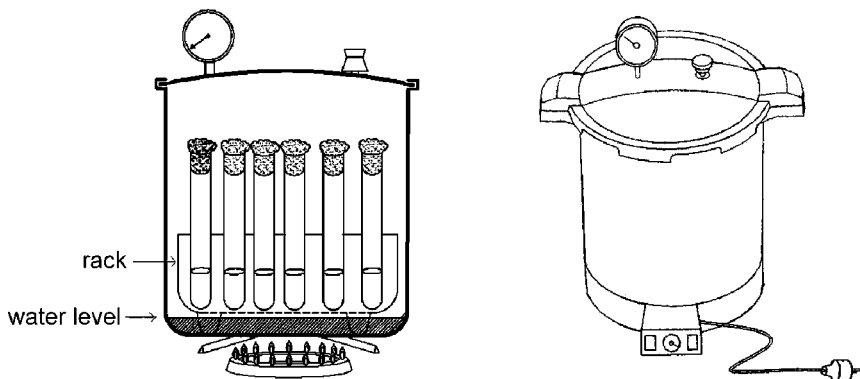

Figure 10: Cross-section of a pressure cooker for use on a burner (left) and an electric pressure cooker or simple autoclave (right)

4.4 Preparation of media

Most species grow on the following media:

Potato Dextrose Agar (PDA) extract medium (see figure 11)

Ingredients: 200g diced potato, 20 g agar powder, 20g dextrose or ordinary white sugar, 1 litre of water.

- Wash and weigh the potatoes and cut them into small pieces.
- Boil for about 15 to 20 minutes until they are soft.
- Remove the potatoes.
- Add water to the broth to make exactly 1 litre.
- Add the dextrose and the agar. Be sure to add the right amount of sugar and agar, otherwise the medium will become either too soft or too hard.
- Stir occasionally and heat gently until the agar has melted. The agar should be hot when poured into the test tubes or bottles otherwise it will become lumpy.
- Fill about one fourth of the test tubes.
- Then seal the tubes or bottles with cotton plugs.

4.5 Preparation of slants

After filling the test tubes or bottles with the medium (see figure 11, picture 5), they must be sterilised (see figure 11, picture 6) before they can be used. The most commonly used sterilisation units in small-scale laboratories are pressure cookers, but autoclaves can be used as well.

Procedure

- Pour water into the pressure cooker to the level of the rack.
- Place the bottles/test tubes in the racks with a plastic covering to prevent water from wetting the cotton plugs.
- Then close the lid firmly.
- At the beginning of the process the air vent should be open in order to allow the air to escape. Some minutes will pass between the moment of boiling and steam escape.
- Close the air vent. A pressure gauge shows the pressure rise.
- Sterilise under pressure for 20-30 minutes.
- Do not open the air vent before the pressure cooker has cooled down completely to room temperature!
- Open the pressure cooker and take out the test tubes or bottles.

To increase the surface area, the test tubes are placed in an inclined position (e.g. on a ruler or a rolled towel) when the agar is still fluid.

Take care that the agar does not touch the cotton plug, in order to prevent contamination.

Do not move or handle the test tubes until the agar has solidified to prevent that a small portion of the agar should solidify at the other side of the slant or too close to the plug.

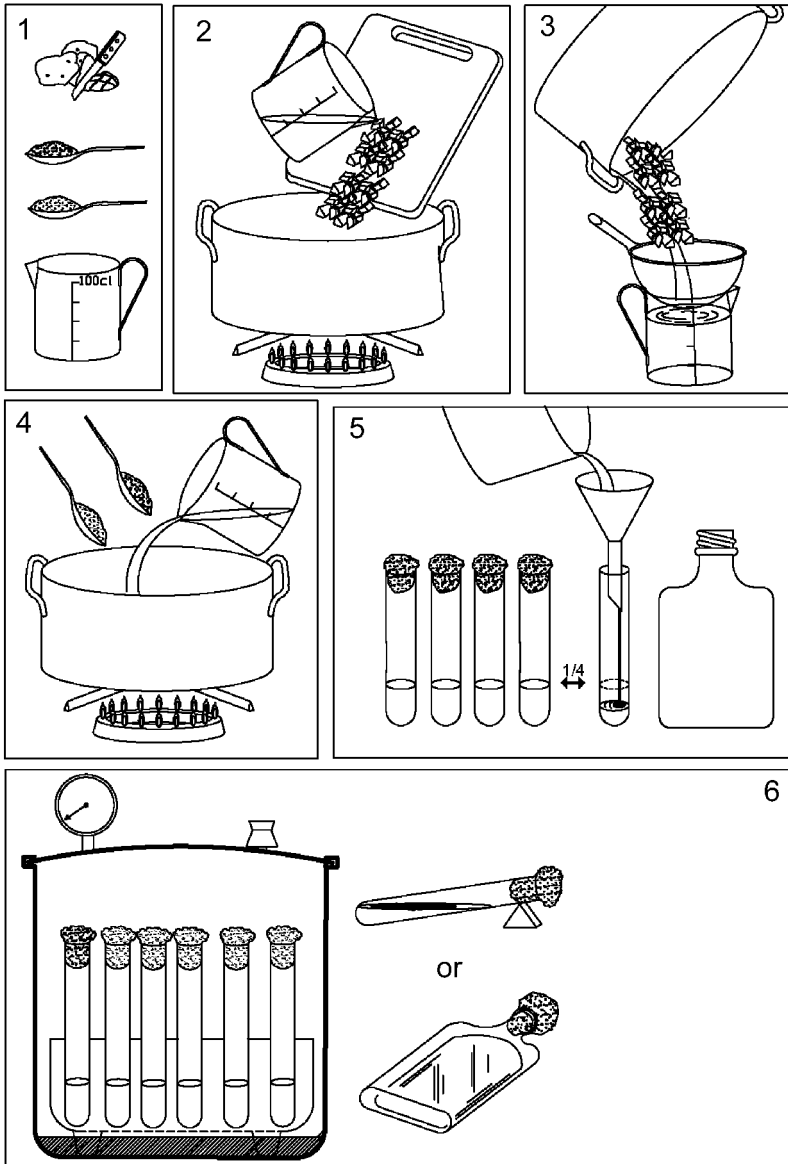

Figure 11: Preparation of Potato Dextrose Agar (PDA) extract medium (pictures 1- 4). Filling (picture 5) and sterilising the slants in a pressure cooker (picture 6).

4.6 Cultures

The first steps in spawn production are performed on artificial media. These should contain sufficient nutrients for the mushrooms to grow, like saccharides and a solidifying agent (agar or gelatine). The mycelium grows on the surface of the medium and will later be used to inoculate larger amounts of grain substrate. Test tubes or Petri dishes (or flat whiskey bottles) are used as culture containers.

Instead of working with cultures, one could also try to purchase small amounts of good quality mother spawn to prepare the final spawn.

4.7 The starter culture

See figure 12:

- 1 The starter culture (or mother culture) can be obtained from a spawn producer or laboratory or made from a fresh and healthy fruiting body.
- 2 More agar cultures are then made from this starter culture.
- 3 More test tubes are inoculated using the methods described for culture transfer (see Appendix 4 for detailed instructions).
- 4 These serve to inoculate larger containers (like bags or bottles) with mother spawn that can be used to inoculate the final spawn substrate.

The mycelium will degenerate after a certain number of transfers, so it is not possible to keep on transferring the cultures on agar forever.

To prevent the spawn culture from degenerating stick to the following rules:

- Never transfer from one mother culture more than eight times.
- Neither use mother cultures on agar for longer than two years.

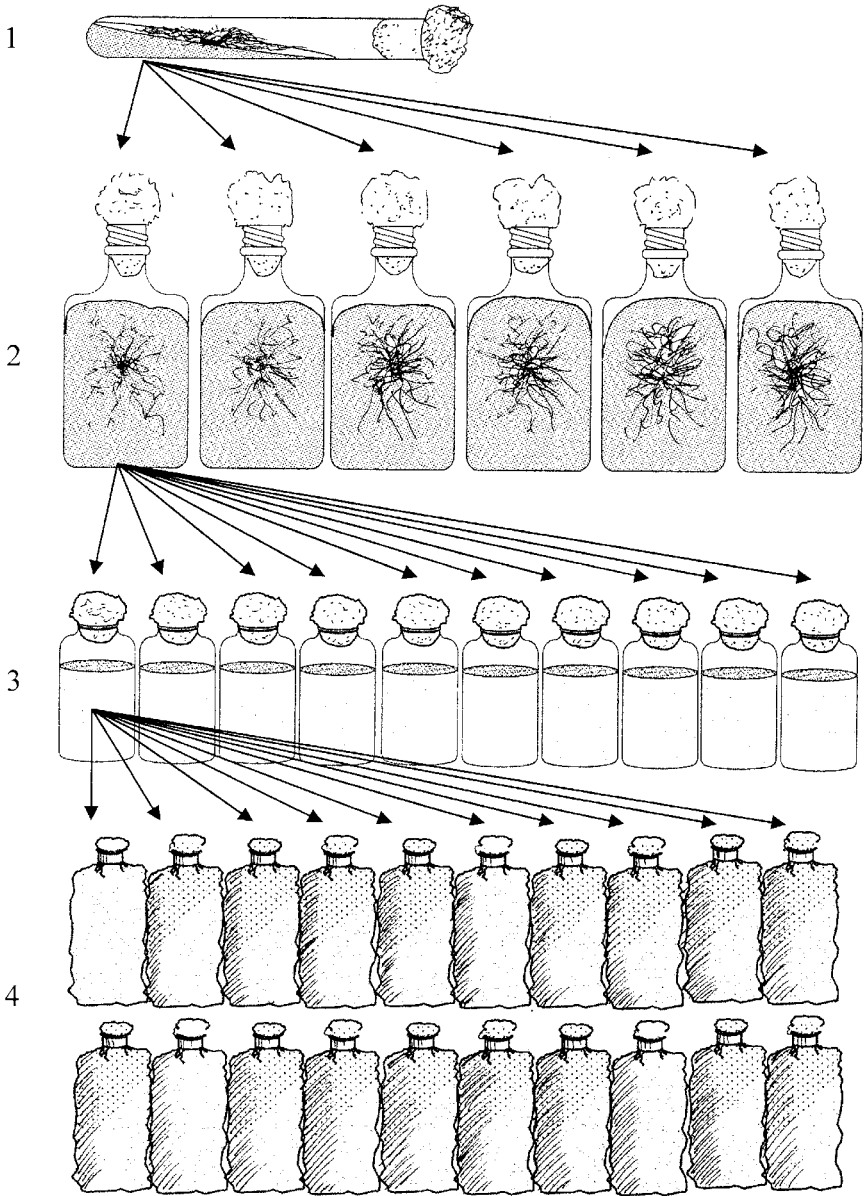

Figure 12: Multiplication of cultures (see section 4.7)

4.8 Tissue cultures

(See figure 13.)

Only in the case that the starter culture cannot be purchased from a spawn producer or a laboratory, the mother culture should be produced from tissue cultures

Young and vigorous mycelium can be obtained from a young fruiting body using a scalpel, alcohol, sterilised agar slants, Petri dishes or bottles with agar, flame (non-smoking), and a clean table to work on, or preferably a Laminar Air Flow cabinet or inoculation box.

- Wash the mushroom thoroughly.
- Dip the scalpel in alcohol, and then flame it until red-hot.
- Let it cool down for 10 seconds.
- Now break or tear the mushroom lengthwise (do not cut it with a knife, since contaminants from the surface can stick to the blade). Do not touch the inner surface with your hands.
- Use the heated scalpel to remove a small piece (2x2 mm is sufficient) of the inner tissue. Take care that no outside surface tissue is included.
- Open the test tube/Petri dish.
- (When using test tubes: heat the mouth of the tube in the flame to kill unwanted spores). Then gently replace the tissue on the scalpel in the middle of the agar.
- Immediately replace the plug.
- Inoculate at least three cultures, but preferably more.

Incubate the newly inoculated agar slants or Petri dishes at 25 °C for about ten days. Within three to four days mycelium will cover the tissue and branch out on the agar.

If no growth occurs on the agar, check the following:

- Possibly the mushroom was too old. Try a fresher specimen.
- Possibly the scalpel did not cool down before taking the tissue sample, thereby overheating and thus killing the mycelium.

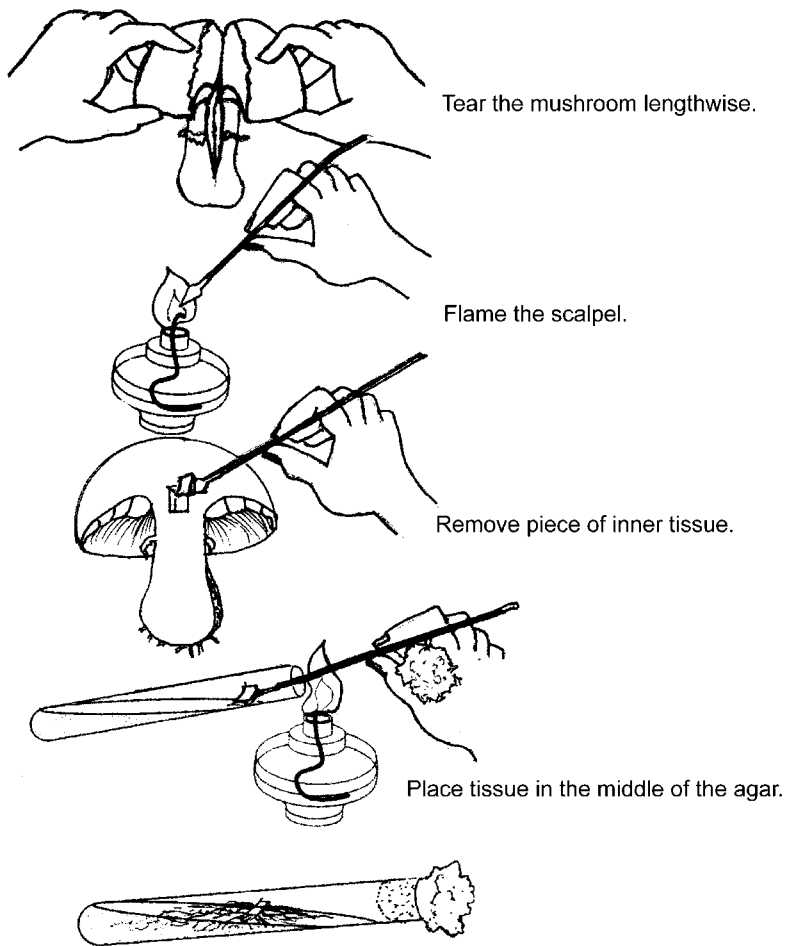

Figure 13: Preparation of the starter culture or mother culture from tissue

The mycelium should be white.

If yellow, blue, green or grey mycelia form on other places on the surface, then these are fungal contaminants. A creamy, shiny growth often indicates bacterial contamination. (See appendix 3: Different origins of contamination)

4.9 Mother spawn

Mother spawn can be used to inoculate either grain spawn or a second generation of mother spawn.

In simple laboratories, mother spawn should not be used to inoculate another generation of mother spawn because of the high risk of contamination

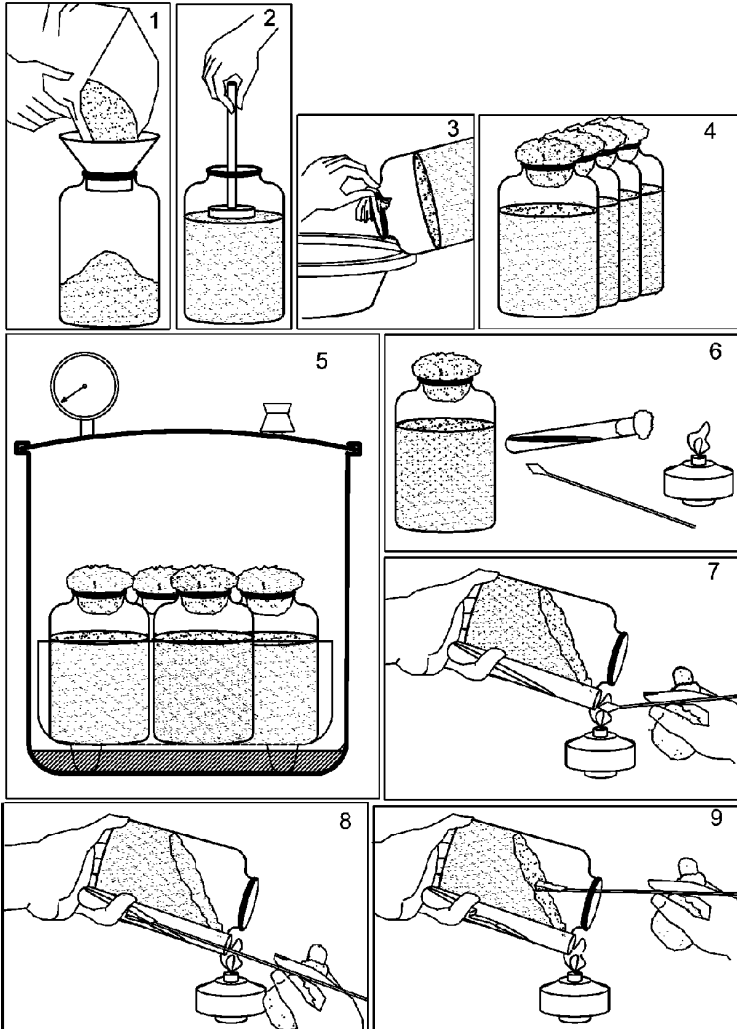

Shake the bottles when taking them out of the autoclave or the pressure cooker.

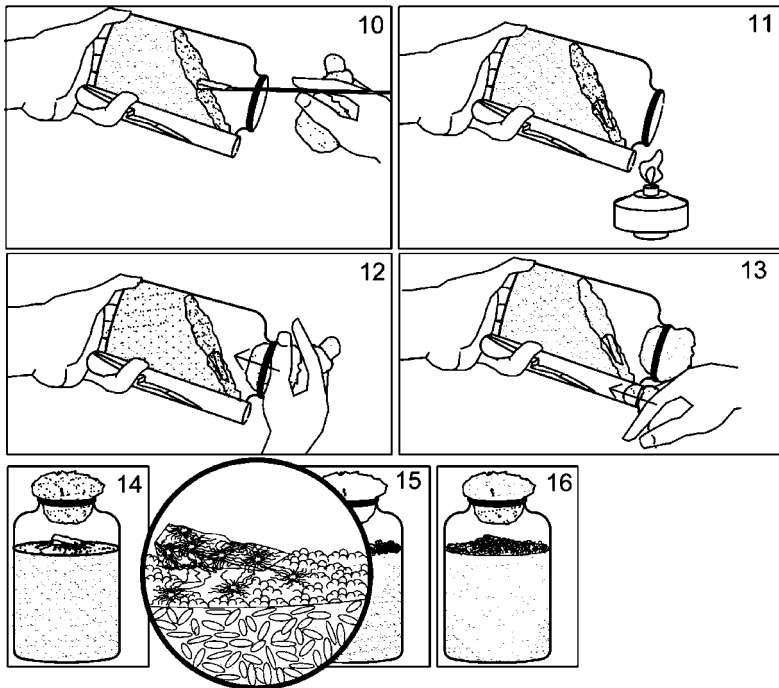

Figure 14: (Pictures 1-5) Preparation of grain spawn in glass bottles. The mouth of the bottle is to be cleaned (3) to prevent spores from germinating. (Pictures 6 – 14) Culture transfer /inoculation of the glass container with mother spawn. (Pictures 14-16). Incubation of the spawn. Magnified detail: The mycelium is growing all over the substrate in the bottle.

Preparation of grain spawn (see figure 14)

For *Agaricus* spp. and *Volvariella* spp. only grain spawn is used. The main advantage of grain is that it is very nutritious for fungi and forms kernels easily. The kernels can easily be dispersed in the substrate. The main disadvantage is that it provides an optimal substrate for other organisms too. The chances of contamination are therefore high.

Kinds of grain

Different grains can be used such as wheat, rye, millet, rice or sorghum. First boil the grain, then drain, fill containers and sterilise.

The moisture content of the grain, after boiling, should be around 50%. If it is higher, mycelial growth may be faster, but the danger of wet spot bacteria is also greater. If it is drier than 35% mycelial growth will be rather slow.

Grain spawn formula 1

Grain in small containers can be moistened to a higher degree than grain in 15 litre bags. For 2 litre containers, use the following recipe: 480 g rye, sorghum or wheat, 400 ml water, 2 g gypsum (45% moisture). (See Appendix 1)

Grain spawn formula 2

Grain spawn substrate: grain 10 kg, CaCo₃ 147.5 g, Rice bran 1.25 g, Gypsum 0.1475g, Urea 0.5 g, Water 1.5 litres. (See Appendix 1)

Sterilisation

Sterilise the spawn containers in an autoclave. The length of time depends on the autoclave, the way the spawn containers are packed (dense or loose) and the size of the containers. For instance, two hours for 500 g containers; three to four hours for 3-kg bags. The spawn containers should be properly cooled down before taking them out of the autoclave.

Steaming in an oil drum for at least 6 hours is usually necessary to ensure proper heating of the inner core of the substrate bags. Sterilise 4-litre bags filled with 2kg spawn substrate for at least 2 hours at 121°C.

Inoculation (see figure 14, pictures 6-14)

Once the temperature in the centre of the container has reached the optimum mycelial growth temperature, the spawn containers can be inoculated. Use at least one square of 10 x 10 mm (for 250 ml bottles) or two squares of 10 x 10 mm (for bigger bottles) from the full-grown agar of the mother culture for each bottle.

Incubation

Incubate the bottles until the mycelium has grown all over the substrate. The temperature should be close to the optimal temperature for mycelial growth. (Consult Table 1).

Shake once (after eight days) or twice during the incubation period (or every three or four days) to distribute the mycelium evenly and to prevent kernels from sticking together.

Storage

Keep the spawn in the refrigerator and only take it out when needed.

At temperatures above 25 °C grain spawn can spoil in one night.

Storage and purity

Good spawn shows vigorous mycelial growth and contains no other organisms. If stored too long it will become less vigorous.

4.10 Preparation of the final spawn

In order to inoculate the compost on the shelves (or the compost in the cultivation bags on the floor) larger quantities of spawn are used; generally referred to as final spawn. In order to prepare the final spawn, plastic bags can be used as spawn containers. The procedure for final spawn is similar to that of mother spawn. Only the sizes of the containers differ. See figures 15 and 16.

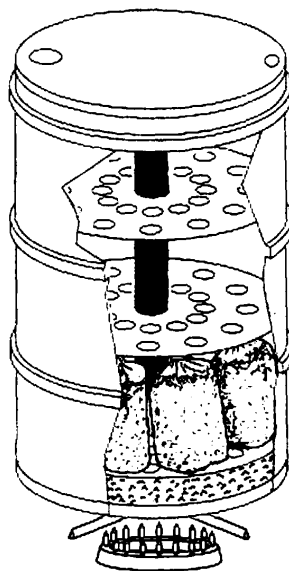

Figure 15: Sterilising large spawn containers in an oil drum

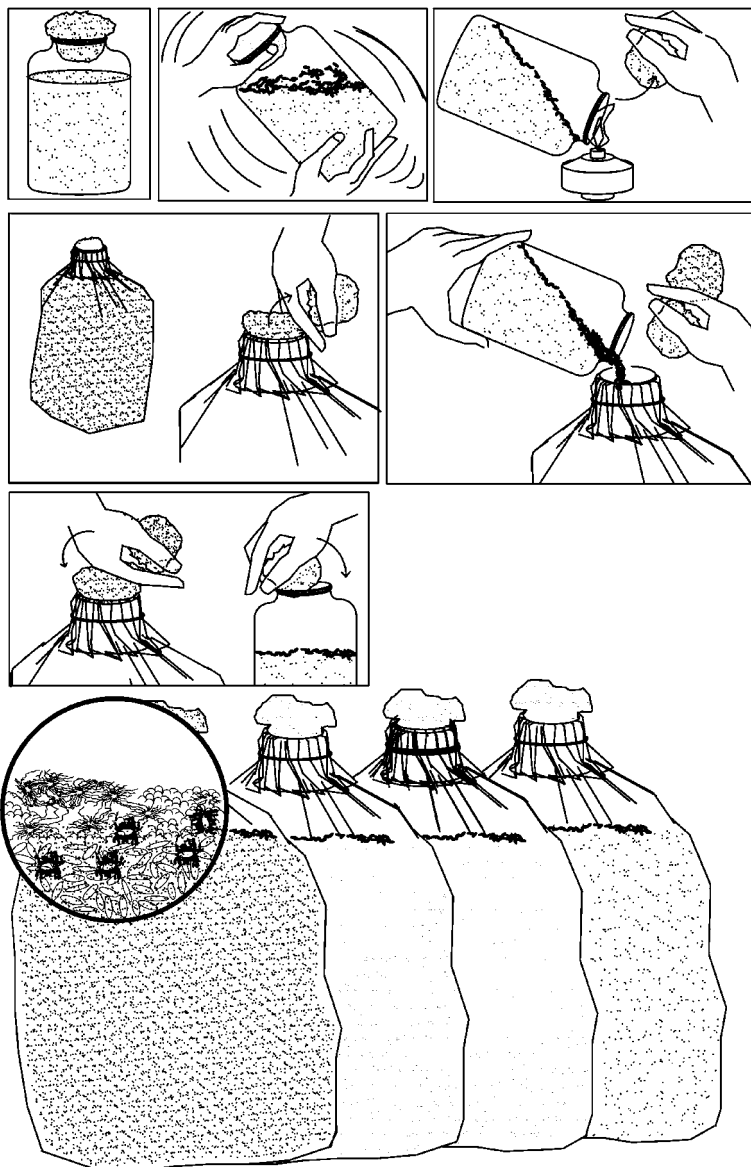

Figure 16: Once the mycelium is full grown (see magnified detail) the content of the bags is ready to spawn the compost in the beds

5 Composting

In nature saprophytic mushrooms are able to obtain their nutrients from plant residues and dead wood. Cultivated mushrooms such as the *Agaricus* spp. (Button Mushrooms) and the *Volvariella* spp. (Rice Straw Mushrooms) can only grow on fermented or composted plant residues. The process of fermenting is called composting. Composting is necessary in order to make the dead organic materials suitable for these mushrooms to grow on.

Thus composting is essential for obtaining:

- a selective nutrient medium (i.e. a nutrient medium that is highly suitable for the mushroom mycelium we want to grow and less suitable for all kind of competing moulds).
- a homogeneous nutrient medium with a homogeneous structure and constant moisture content.

Materials

Farm waste such as wheat straw, rice straw or pressed sugar- cane (bagasse) is generally used as basic organic material for composting. Check which sources are available in the region and make sure that there is a constant supply of good quality basic materials. Good quality straw means: the straw is dry and not rotten. To ensure a good mixing the straw should not be stacked in bundles or bales, but should be cut to a size of about half a meter.

Structure of the straw

While most wheat straw has a good structure, rice straw easily clogs up and congests when it remains too wet. Moreover, if the straw particles are too short, air will not pass through easily. For similar reasons hay from dried grasses is less suitable; as soon as the materials are wet they will form clumps and block the airflow inside the heap.

Mixing is the most important part of compost preparation. Most of the complaints about poor compost are related to poor mixing.

In the case of bagasse, it is important that it ages in the open field before usage, so that sugar residues will leach out by rain, thus preventing harmful fungi, which feed on these sugars, from growing.

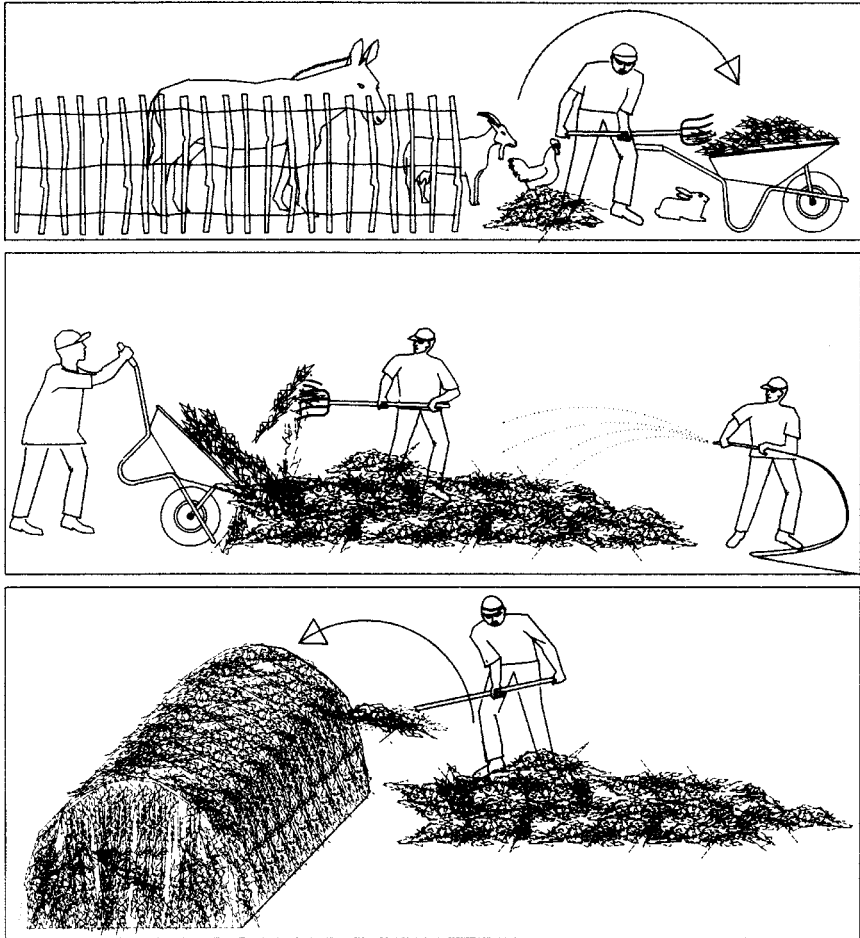

Figure 17: Stacking and turning the compost heap. Temperature in the compost heap should not exceed 55°C. to prevent loss of valuable nutrients.

Manure

As a protein source, mostly straw-rich stable manure of animals is used. Usually, horse manure or chicken manure is used but the manure of other animals can also be employed. Poultry manures tend to have a higher nutrient content than horse or cow manure and is often further concentrated through drying.

If manure is scarce or not available at all, artificial manure such as urea can be used as well. Besides manure, gypsum or chalk is added. Moreover, like in all bacteria and fungi-induced processes water is needed during composting.

Last but not least, once the materials are piled up, aeration of the heap of organic materials is an important procedure. Aeration is vital to ensure a proper decomposition and to avoid unwanted anaerobic and smelly processes. It is for this reason that the organic material should have a good structure. Neither should it be too compact when piled up.

Recipe 1

1000 kg of straw-rich stable manure or straw mixed with chicken manure, thoroughly mixed with 10 kg of chalk.

Water is added until it leaks out of the pile.

Recipe 2 (to be used if no manure is available) See appendix 5

1000 kg straw

10 kg urea

20 kg ammonium sulphate

8 kg potassium sulphate

25 kg calcium carbonate

Location of the compost site

When selecting a location for composting, one has to keep in mind that the site should not be in the proximity of houses, to avoid complaints about smell. The composting site should also be located at a certain distance from the growing rooms and the laboratory.

If storage of basic materials and composting takes place close to growing rooms, pests and diseases can easily spread towards these growing rooms. Although it will cost more labour and effort to move the compost into the growing rooms, the result will be an improvement of farm hygiene. This extra effort for transportation is minor compared to the risks, costs and losses that come with a heavy crop infestation caused by neglecting the basic rules of farm hygiene.

Composting preferably should be done on a concrete slab. If possible the concrete slab should be constructed with a slight tilt, with a cemented basin at the bottom end to collect the water leaking from the compost.

This run-off water (or goody water) can be reused for watering the compost.

Dimensions and form of the pile

The materials are piled up in compost heaps (see figure 17) that have standard dimensions; they do not exceed a height of 1.5 m and are straight sided. In mushroom cultivation these dimensions have proved to be most efficient and to guarantee a proper decomposition of the used materials.

Roofing

Above the concrete slab some roofing is recommendable in order to prevent that the compost heap dries out by sunlight or gets soaked by heavy rains.

Composting process

Composting is a process of decay caused by microorganisms, which results in a selective and nutrient-rich substrate suitable for the mushroom we intend to grow.

Standards that are essential for a successful compost preparation are indicated below.

Watering and prewetting

The dry organic material is piled up on a heap and wetted with water. The heap has to be kept moist but not soaked, so that soluble nutrients will not leach away.

This prewetting stage will take about 5-6 days and every day some more water is added. The practice of wetting should soften the outer layer of the straw by decomposing its wax layer. Some times prewetting is performed by soaking straw for a few days in a water basin.

Aeration

After the prewetting stage the straw and manure are thoroughly mixed and stacked into a pile with a height of 1.5 meter. The inner part of the pile should not be too dense in order to enable a good aeration.

Composting is a biological process that generates heat. When composting is performed properly, temperatures may rise to 60 °C. A good compost pile will produce some steam. A simple method to check the temperature of the pile consists in putting a hand into the pile. You will be able to stand a temperature of 55 °C, so when the temperature is higher you are forced to quickly withdraw your hand.



Figure 18: Checking the temperature in the compost pile

A well maintained compost pile produces hardly any bad odours, but will produce some steam.

When a lot of vapour escapes from the compost pile and temperature exceeds 60/70 °C, the compost is too hot. In that case it is wise to lower the temperature by turning the heap inside out.

Mixing and Turning

The rate of decay is accelerated by turning and mixing the pile at intervals.

Although proper mixing is extremely important, this aspect of composting is often undervalued. In order to achieve a successful composting process it is essential that the materials are thoroughly mixed before piling them up!

Frequent turning of the heap is required in order to

- ensure a quick and proper decomposition
- prevent the compost pile from overheating
- obtain a homogeneous structure.

At the first turning add gypsum and also make sure that manure lumps are broken and the compost is thoroughly mixed

Basic turning schedule

A basic schedule includes turning the pile after 5 days and consequently another 4 times every 3 days. Make sure that during turning of the heap the outer layer of the compost will end up on the inner side of the new heap and vice versa.

Moisture

Biological processes, such as composting, need water. During the entire process the compost should be kept moist but not wet to the extent that water is leaking out. On the other hand, when the compost is too dry, water should be added to get an optimal process. In case rice straw is used, special attention should be paid to the applied amount of water, in order to prevent clumps of compost, which will block the airflow in the heap.

Moisture content about 60%

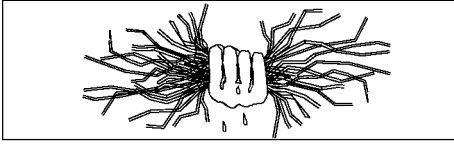

Too dry

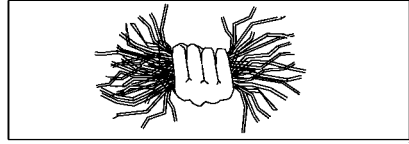

Figure 19: Squeeze test. Squeezing a fistful of compost, only a few drops of moisture should appear between the fingers. In that case, the moisture content is approximately 60 %

Once the compost is ready, it is to be transported either to the shelves in the growing rooms or to fill the plastic growing bags or other containers.

In many regions, groups of mushroom farmers jointly prepare compost at a central location. From this location the compost is then transported to the individual farms.

6 Cultivation of Button Mushrooms (*Agaricus* spp.)

Most cultivated Button Mushrooms belong to the species *Agaricus bisporus*. This species is rather difficult to grow under primitive circumstances. Therefore small-scale mushroom growers are advised to grow locally available *Agaricus* varieties.

6.1 Pasteurisation or peak heating

Fresh compost is not immediately suitable for mushrooms. It requires further treatment. Therefore, fresh compost has to be transported to the growing house and placed on the shelves or brought into a tunnel for the next phase. This phase is called peak heating or pasteurisation. Peak heating is necessary in order to destroy unwanted organisms and microorganisms, such as flies, bacteria and green moulds. The optimal compost temperature for pasteurisation is 60 °C and should be maintained for at least 8 hours. Steam is used to heat up the rooms. A simple method to generate steam is through heating water in oil drums and leading the steam through a hose into the growing room or the tunnel. (See also appendix 6: Simple steaming systems)

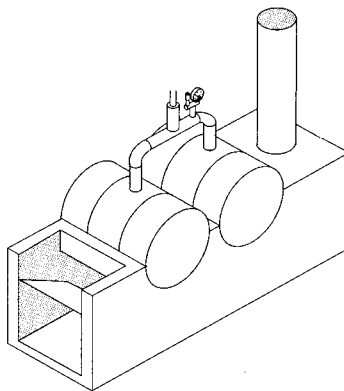

Figure 20: Steam producer made from oil drums

The pasteurisation or peak heating procedure is followed by the conditioning phase in order to prepare the substrate for spawning. Conditioning implies gradually lowering the temperature within 1 or 2 days and is necessary to get rid of the free ammonia in the compost. Spawning cannot take place at temperatures above 30 °C.

Actinomycetes

During the period between peak heating and spawning, white fungal spots caused by Actinomycetes will develop in the compost. These fungi will not inhibit the mycelial growth of the mushrooms.

Some people appear to be allergic to Actinomycetes. These persons should not be involved in, or carry out the spawning procedure.

6.2 Spawning

When the temperature has dropped sufficiently (preferably below 30 °C), spawn has to be added and mixed through the compost. This process is called spawning. Button Mushroom growers generally use about 6-8 litres of spawn per 1000 kg (1 tonne) of pasteurised compost. The spawn has to be mixed homogeneously through the compost layer.

Mycelium growth

After spawning the mycelium will start to develop. The optimal temperature for mycelial growth is about 25 - 27 ° C. Sufficient moisture is another important factor for mycelial growth. As a consequence the Relative Humidity should be very high (RH 95% or higher)

To achieve such a high RH, several measures are to be taken:

The compost on the shelves or in the bags should be covered with sheets of non-printed newspaper. The paper sheets are to be sprayed regularly, as well as the walls and floors. In general, it takes 2 weeks before the compost layer will be sufficiently colonised by the mycelium. At this stage the compost is referred to as full-grown compost.

In literature supplementation (adding high-protein nutrients to the compost) is often mentioned with regard to boosting yield levels.

However, if adequate cooling of the growing rooms is not feasible, supplementation will have an adverse effect on the yield.

Overheated compost will not produce any mushrooms at all. As a consequence, supplementation should be performed exclusively on more sophisticated farms with cooling units.

6.3 Casing

The compost layers are now full-grown with mycelium, but they will not produce a good mushroom crop yet. Therefore, the Button Mushrooms need a layer of casing soil.

The casing soil will provide the right bacteria and the right amount of water, stimulating the mycelium to form a good crop. Watering directly on the compost would cause rot and, consequently, no mushrooms would develop. The casing soil will also serve as a water buffer.

Formula 1

Course peat 4 parts

Limestone 1 part

Formula 2

Loamy soil and coconut fibre mixture

Casing soil can be made from peat. If peat is not available, a good alternative would be the use of soil without parasites, dug from at least 50 cm deep.

The casing soil is applied on top of the full-grown compost in a layer up to 5 cm thick.

To check the water-holding capacity of the casing soil;

- Put a layer of 5 cm thick on a frame covered with an insect screen.
- Irrigate in the same way as in the growing room.

- The moment water passes through the screen, the soil's water holding capacity will have been reached.

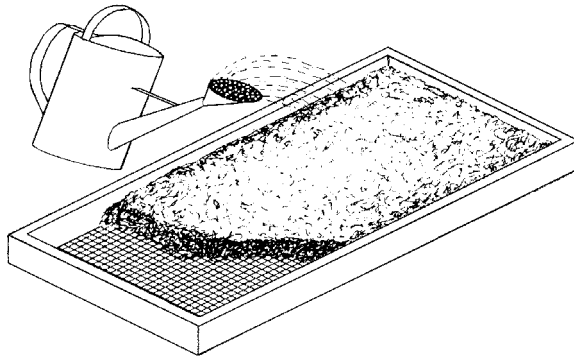

Figure 21: Water holding capacity check

Beware of spraying too much water on the casing soil, in order to prevent water from seeping through the casing soil towards the compost and causing rot!

Ruffling the casing soil

When the mycelium has grown well through the casing soil, the procedure of ruffling can start. Ruffling implies that the mycelium is mixed by lightly raking the casing soil layer, to get a more uniform mycelium growth. The ruffling procedure will break the mycelium in the casing soil layer, stimulating regrowth.

Cooling down and formation of fruiting bodies

When the mycelium has a fluffy white appearance and has grown well into the upper layer of the casing soil, cooling down can start. This measure is taken in order to trigger the change from vegetative growth (mycelium) to generative growth (fruiting bodies). This climate change can be achieved by increasing the air ventilation. If possible the compost temperature should be reduced with about 5-6 °C to approximately 20 °C, within a few days. Each strain has its own requirements. If a temperature reduction is hardly feasible, mushrooms may

develop but the yields will be low. Be aware that modern *Agaricus* varieties require a strict cooling down.

Spraying water and Relative Humidity (RH)

As soon as the mycelium stops growing, the mycelium threads start to form clusters and form little pinheads. Since the pinheads are very sensitive to dehydration, a high RH is required. As soon as the fruiting bodies are pea size, spraying water can start. The amount of water used depends on the speed of growth, the expected yield and the way of harvesting. By rule of thumb 1 litre of water is sprayed for each kilo of mushrooms to be harvested.

Spraying can be carried out either before or after harvesting.

Make sure, however, that the mushroom caps are dry within one hour. Otherwise bacterial blotch will develop on the mushrooms.

This bacterial blotch is also triggered by insufficient ventilation and by weak mushrooms.

6.4 Harvesting and picking

In general the first mushrooms can be harvested approximately 3 weeks after casing. The mushrooms are picked manually according to their required size. This size will differ according to the customer's requirements: some customers like small closed Button Mushrooms, while others prefer large open ones ('flats'). Each individual mushroom is removed from the casing soil, pulling it carefully by the cap with a light rotating movement. Depending on the mushroom size, two, three or four specimens can be picked in one hand. The sandy stumps are cut away from the stems and the mushrooms are graded and packaged according to their required quality.

Picking of the mushrooms should be done with clean hands and bruising of the caps should be avoided.

The mushroom harvesting period will last several weeks, depending on the growing schedule and compost quality

At the end of the harvesting period, the compost in the growing rooms has to be steamed again ('cooking out') in order to destroy the mycelium and more importantly to exterminate any adverse organisms.

Afterwards, the spent mushroom substrate (SMS) can be used to improve garden soil.

6.5 Case description Button Mushrooms

In the Chiang Mai region, Northern Thailand, some farmers grow *Agaricus* spp. (Button Mushrooms) during the cool season.

Ingredients

For compost preparation, rice straw is used and mixed with urea and gypsum. Rice straw is abundantly available in the region.

Recipe: 100 kg rice straw

5 kg urea

2-3 kg Super phosphate.

The rice straw is cut in pieces of about 75 cm, wetted for 2 days in concrete basins and mixed thoroughly with the other ingredients. Then the straw mixture is piled up in heaps of about 1.5 meter high using a metal frame to ensure that the compost heaps are neatly packed and straight sided.

Turning and mixing

Turning of the compost is done every 2 days. After one week the compost is ready and transported into the growing house on shelves in a layer of 15 cm thick (about 80 kg/m²).

Temperature treatment and conditioning

The compost is pasteurised with steam for 6 hours. After cooling down and conditioning the compost is spawned.

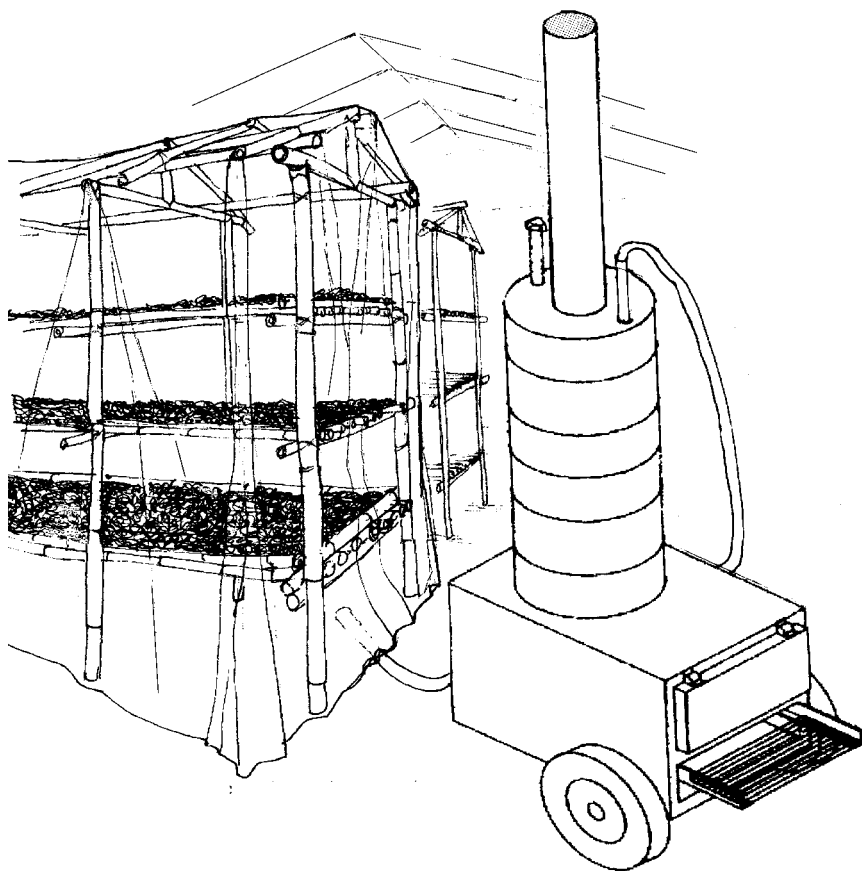

Figure 22: Steaming of the growing room/compost in the beds

Spawning the substrate

Grain spawn is purchased from distributors or is produced by the growers themselves using mother cultures purchased from laboratories. The spawn rates are variable and range from 3-7 litre per tonne of compost.

Casing

After the spawn run is complete, a 5 cm layer of casing soil is applied, using red sandy loam and some coconut fibre.

Construction of the mushroom house

The growing rooms are similar to the ones used for the cultivation of rice straw mushrooms. They are constructed from bamboo and have plastic linings. The roofs are generally double layered with bamboo leaf mats at the outer sides.

Temperature control

Wetting these leaf mats by water sprinklers induces evaporation and therefore will lower temperatures in the growing room. By sprinkling the floors with wet sand another temperature drop of approximately 5 °C is achieved. No further ventilation or climate control is available.

Harvesting and marketing

Harvesting is done daily. After the mushrooms have been brought to the collecting place, the stems are trimmed. Yields obtained are approximately 80 kg per ton compost.

The Button Mushrooms are sold fresh to individual customers on the nearby markets or are sold through a middleman to the canning industry.

7 Cultivation of Rice Straw Mushrooms (*Volvariella* spp.)

In cultivation of Rice Straw Mushroom (*Volvariella* spp.) two methods are employed: indoor cultivation and traditional outdoor cultivation.

Outdoor cultivation

In several Asian countries farmers grow Rice Straw Mushrooms in a corner of their fields, after harvesting the rice crops and before starting the new rice-growing season. This outdoor cultivation hardly requires any investments other than labour. However, yields are generally very low, due to pests and diseases. Therefore, this method will not be elaborated in this booklet

Indoor cultivation

Indoor cultivation requires investments but it will produce a more reliable yield. Loans can often be obtained from companies or micro-credit organisations, in order to start a farm. Rice Straw Mushrooms grow rather quickly, compared to other mushrooms such as e.g. Button Mushrooms.

This guarantees a fast return on investments. *Volvariella* mainly utilises cellulose as a nutrient and therefore higher yields are obtained from substrates with high cellulose content. For that reason cotton waste usually is mixed with rice straw.

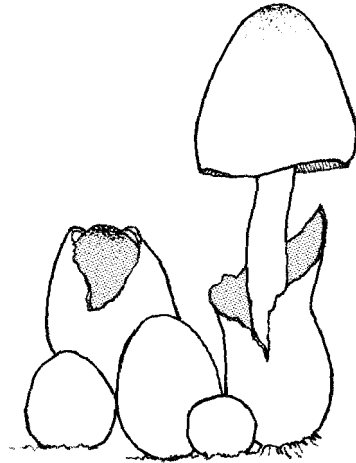

Figure 23: Different stages of *Volvariella* spp.; from tiny button to mushroom. Full growth of the mushroom takes only three to four days

Requirements for indoor cultivation:

- plastic mushroom shed with shelves or an industrial building (with water resistant and heat resistant walls)
- concrete floor for composting phase
- steam boiler
- forks for composting, filling the shelves and spawning.
- spawn
- basic materials for composting such as rice straw, cotton waste, etc and a good water supply.

Formula 1

rice straw	45%
cotton waste	40%
rice bran	10%
lime	5%

Formula 2

dry cotton waste	90-92%
rice bran	4%
limestone (pH regulator)	4-6%

See Appendix 5 for more substrate formulas.

Substrate preparation

The dry materials have to be moistened thoroughly, for instance by soaking them in water. Cotton waste may get completely saturated with water, thus preventing the access of air. It should therefore always be mixed with another material, such as rice straw, to ensure sufficient aeration. Use the squeeze test to determine whether the substrate materials have absorbed sufficient or excessive amounts of water.

Then form piles of at least 1.5 m³ and cover them with plastic to avoid loss of water and energy; evaporation consumes large amounts of energy.

The heaps should be turned once or twice within a total period of two to four days in order to prevent long-term anaerobic conditions in the heap. Add rice bran or another supplement during the last turning of the heap. Since the supplements provide easily degradable nutrients for microorganisms, the temperature of the substrate will increase.

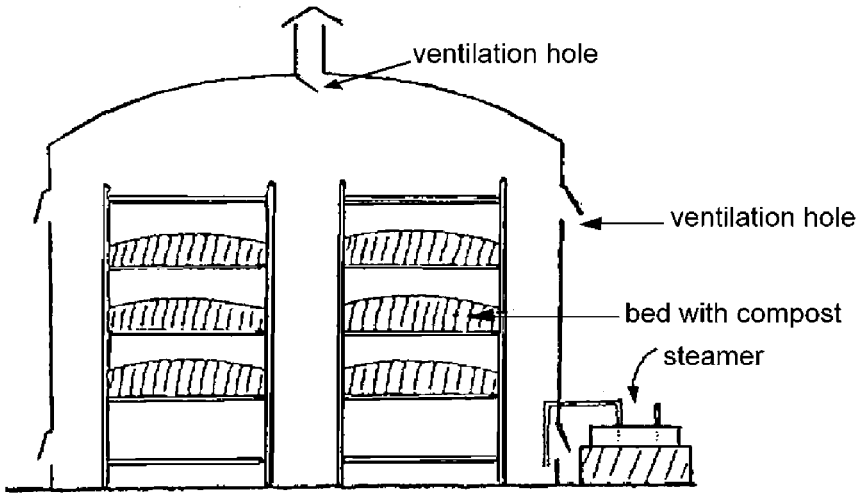

Figure 24: Cross-section of a growing room with compost beds on shelves. The room can be steamed with the oil tank steam producer (right).

Peak heating

The substrate is now ready for heat treatment. Beds in the growing room are filled with a substrate layer of 10 to 15 cm thick (about 50 kg wet substrate per m², i.e. approximately 15 kg of dry substrate material per m²). Steam is blown into the growing room until the substrate (not the air!) has reached a temperature of 60 °C. The steam inlet is adjusted to stabilise the substrate temperature for about three to four hours.

Actinomycetes

During the period between peak heating and spawning white fungal spots, caused by Actinomycetes, will develop in the compost. These fungi will not inhibit the mycelial growth of the mushrooms.

Spawning

Spawning occurs as soon as the temperature drops below 37 °C. Spawning rates differ among producers, depending on the vigour of the strain involved. Usually about 1% is used, with upper and lower ranges of 0.5% and 5% (w/w). *Volvariella* spp. grows very fast, so 1% is often sufficient.

Different spawning techniques and spawn substrate materials may be used. Some growers use a short fork to mix the spawn evenly with the substrate, while others make holes with a wooden dibble and insert peanut-sized pieces of spawn, at 12 to 15 cm intervals, at a depth of 2 to 2.5 cm.

Some people appear to be allergic to Actinomycetes. These persons should not be involved in, or carry out the spawning procedure.

Spawn run

Cover the substrate with plastic to keep the temperature high (35 °C) but not above 40 °C. *Volvariella* will colonise the substrate in only a few days. Remove the plastic after three days and ventilate some more after six days.

Light

Light is also needed for the formation of fruiting bodies. Use white light or make sure some daylight can reach the substrate as from three days after spawning. Just a little light is sufficient; 15 minutes of sunlight or a day/night cycle of 500 lux have been reported to be sufficient. When one can read a newspaper inside the growing room, the supply of light is sufficient.

Humidity

Spray a fine water mist to maintain optimum humidity and take care that direct watering does not damage the delicate mycelium.

Harvesting and Picking

Although this may require two or three pickings per day, the mushrooms should be picked while still young, i.e. when they are in egg stage and the cap has not ruptured the veil yet. Opened ones are difficult to sell, because they have to be consumed the same day. Be careful not to bruise the mushrooms while picking them.

The production level is acceptable when the mushroom yield (fresh weight) equals 25% or more of the dry weight of the compost. Since straw mushrooms can be grown very quickly, a relatively high output can be reached per growing period, although their yield is significantly lower than that of other mushrooms. At the end of the harvesting period the compost in the growing rooms have to be steamed again ('cooking out') in order to destroy the mycelium and, more importantly, to exterminate any adverse organisms.

Spent Mushroom Substrate

After cultivation the spent mushroom compost (SMS) can be used to improve garden soil. In some countries the spent compost of Button Mushrooms is used to grow a crop of Rice Straw Mushrooms. The beds with the old compost are emptied and the house is cleaned. Cotton waste is mixed with the old compost and fermented for some days. Then a heat treatment is applied. Seven to nine days after spawning, the first pinheads appear. Usually two flushes are harvested.

7.1 Case description Rice Straw Mushroom cultivation

In the Karawang Region East of Jakarta, Indonesia, many small farmers grow Rice Straw Mushrooms on low investment small-scale farms. Rice Straw Mushrooms, *Volvariella* spp., are suitable for cultivation in warm climates.

Quite some villages in this predominantly rice growing region have clusters of small mushroom growers. Each grower owns one (sometimes more than one) simple mushroom growing house, made from bamboo with a plastic lining at the inside. Since the Karawang Region is actually a rice-growing region, rice straw is abundantly available but is considered an agricultural waste and just left on the field.

Compost

The major basic material for compost production is rice straw

The other ingredients are:

- chicken manure or urea
- cotton waste
- rice bran and
- gypsum.

Composting process

After thoroughly mixing and wetting, the materials are piled on heaps with a height of about 1.5 meter. In general, the heaps have some sort of cover to protect against excessive climate conditions and prevent drying out by the sun or soaking by rain.

Temperatures in the heaps rise up to 60 C° and in general the heaps are turned every 2 days to avoid overheating of the compost. In general, the compost will be ready in 6-8 days.

Filling the beds

The compost is transferred and put in 20 cm thick layers in the shelves in the growing house. The compost layers in the shelves are covered with a thin layer of coconut fibres. Sometimes, the coconut fibres are mixed with some cottonseed waste.

Growing houses

Each growing house has 2 rows of 5 shelves high. The distances between the shelves vary, as well as the thickness of the compost layer, in order to ensure that the temperature will be the same in all layers.

The inner side of the growing house is enclosed with plastic. The costs of a growing house are about €150 - €200 for materials.

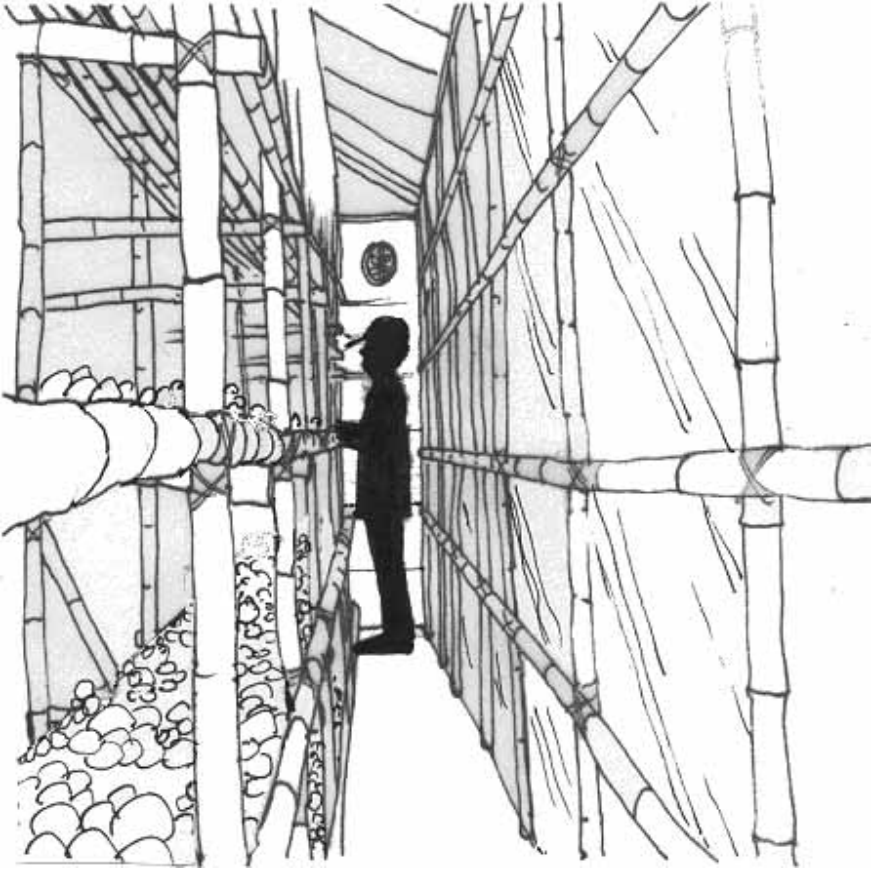

Figure 25: Harvesting from bamboo racks

Pasteurisation

Subsequently the compost in the growing house is pasteurised for 6-8 hours at about 60 C°. Pasteurisation is done by steam produced through heating oil drums filled with water. The steam is led into the growing room by a rubber hose.

Spawning

After pasteurisation and cooling down of the compost, the substrate is spawned. The spawn run will take 7-10 days. Spawn is generally bought from spawn distributors, who obtain it from larger laboratories. In this region the *Volvariella* species used is suitable for these high (33 °C) temperatures.

When the spawn run is complete, more air and light is let into the growing room to induce fructification. Harvesting will take place 2 times a day, over a period of 2-3 weeks. The yearly production of an average growing house with a surface of about 100 m² is approximately 200,000 kg.

Marketing

Marketing is performed by farmer groups or through middlemen. The mushrooms are sold on the various markets of Jakarta, where Rice Straw Mushrooms are in demand. The average grower will have an income of about €1,500. In general some of these revenues are used for school fees or for medical bills.

8 Harvesting and post harvest handling

Edible mushrooms are a delicate product with a short shelf life. Most of the time mushrooms are marketed fresh but they can also be preserved. This chapter pays attention to:

- harvesting
- how to handle mushrooms for the fresh market
- preservation.

8.1 Harvesting

Button mushrooms as well as Rice Straw Mushrooms should be picked at the stage at which they have the highest profitability that is when the cap is still closed. When picking mushrooms, take care to gently break them from the substrate or casing soil. Avoid tearing away chunks of mycelium from the substrate/casing soil. The well-developed specimens have to be picked very carefully from mushroom clusters in order to leave the small ones to continue growing. Since mushrooms can easily be damaged, it is best if handling is kept to a minimum. Immediate trimming and grading, when picking, and packaging them in the packages in which they will be sold, ensures that they are touched only once: at the moment of picking.

After picking, mushrooms should be kept as cool as possible. If no cooling facilities are available, then put them in a shady place. When placed on a wet concrete slab and covered with a wet cloth, the boxes with picked mushrooms will keep cool for several hours. Make sure that the wet cloth does not touch the mushrooms!

8.2 Fresh market

Under ideal conditions, mushrooms for the fresh market are cooled rapidly after harvesting and then packaged with a plastic film. The plastic film provides good protection from water loss, as long as the

storage temperature is more or less constant. Repeated exposure to fluctuating temperatures should be avoided.

When the temperature goes up, the mushrooms will lose water. When the temperature drops, water will condense inside the package and on the surface of the mushrooms. This will lead to fast wilting. Make sure that the mushrooms are cooled down before wrapping or covering them in plastic in order to avoid condensation within the package.

8.3 Preservation

Preservation of mushrooms is necessary only when harvested mushrooms cannot be sold fresh. There are many different preservation methods but for small farms many of these methods, including the commonly used canning method, are too complicated and the equipment is too expensive. Therefore, they will not be described here.

The simplest method is cooking the mushrooms in water in order to stop growth and enzymatic processes. Take the mushrooms out of the cooking water, cool them down and package them together with the cooking liquid in plastic bags, which are to be sealed immediately afterwards. This method is used quite often for Rice Straw Mushrooms. Mushrooms treated in this way will keep for 1-2 days.

Another method is blanching the mushrooms by cooking them for 10 minutes in water at a temperature of 90° C (preferably 1 kg of mushrooms in 5 litres of water). Cool them down after blanching. When mushrooms appear floating on the surface they have not been blanched sufficiently. After cooling down, put the blanched mushrooms in twist-cap glass jars and fill up with a watery solution of 2% salt and 0.2 % citric acid. Heat the closed jars for about an hour. This product will keep for weeks.

For both methods it is necessary that the procedure be performed in a clean and hygienic way in order to avoid problems of contamination and to assure good quality.

8.4 Drying

Drying has several advantages: it is easy, quick and safe and well-dried mushrooms can be stored for a long time. Besides *Agaricus* spp. and *Volvariella* spp., many other cultivated and also wild mushrooms are commonly sold dried.

Drying by sun

In tropical areas, many edible products are displayed on racks to dry in the sun. The sun warms up the products as well as the surrounding air, causing evaporation of the products' water content. Besides drying on racks, the drying procedure can be performed in simple constructions, known as sun driers. A sun dryer can function in a direct or indirect way.

Direct sun dryer

A direct sun dryer (figure 26) is not expensive and is easy to handle. A disadvantage is that it allows hardly any control of the temperature; neither is the product protected against external influences.

Indirect sun dryer

With an indirect sun dryer (figure 27) temperature can be controlled better. And as the product is not exposed to UV light, fading will not occur.

During the drying process the following rules should be observed:

- The mushrooms should not touch each other.
- Air circulation is very important; put the mushrooms on a grill rack or a metal grid.
- Since the freshest mushrooms lose much water through evaporation, they should be put on the lowest tray.

Mushrooms do not have to be crisp to the touch after drying; they should still be slightly flexible. The quality of sun-dried mushrooms is generally less than that of artificially dried ones. The moisture content of sun-dried mushrooms is higher and therefore they can be kept for a shorter period than the artificially dried ones.

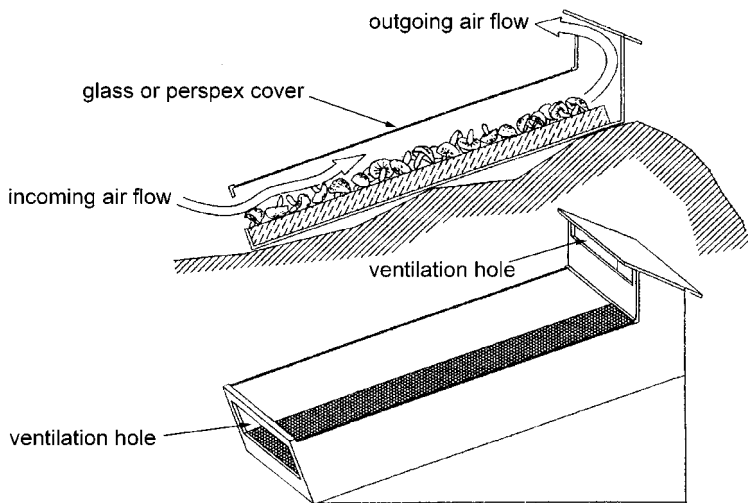

Figure 26: Direct sun dryer and cross section of the same dryer

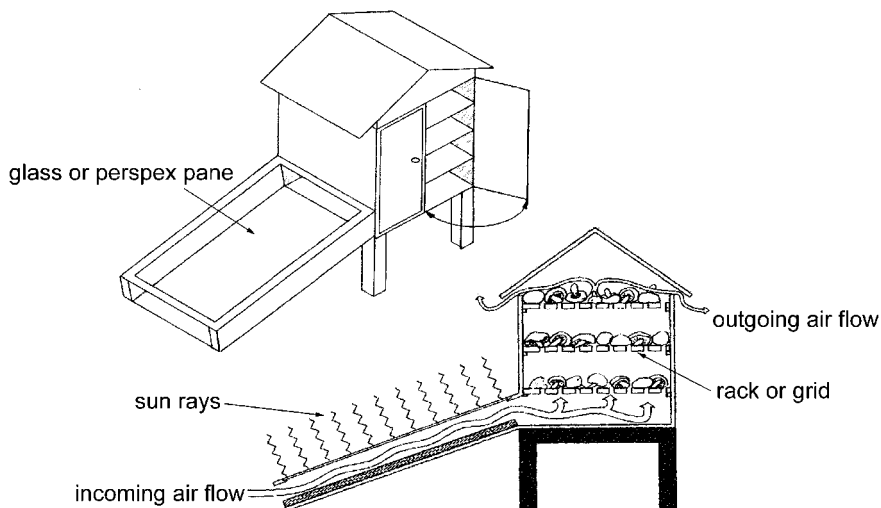

Figure 27: Indirect sun dryer and cross section of the same dryer

Packaging and storage

All foreign material should be removed at the end of the drying process. Dried products easily absorb water from the surrounding air because of their low water content, so packaging has to take place in a dry room.

It is a good idea to finish drying during the warmest part of the day when the relative humidity is at its lowest. The product can be cooled in the shade and if the work is done hygienically, the cooled products can be packaged immediately.

The packing material must be waterproof, airtight and insect-proof. The dried products will only remain good if stored in such a way that they are dry and protected from insects. Normal plastic bags (properly sealed) will do for some time, but are not entirely gas and waterproof. It is also possible to use polymer-coated cellophane bags, which are waterproof and airtight. These can be sealed with a hot iron or a sealing machine (where electricity is available). Unfortunately this kind of plastic cannot be easily obtained and is not too strong either.

A plastic bag of thicker quality (polyethylene, 0.05 mm thick) is best. These can be closed tightly with a metal clip or with cellophane tape.

From a marketing point of view it is recommendable to include a sticker describing the product and a recipe.
--

9 Marketing

Marketing is a vital aspect of developing a healthy business. Marketing includes products, prices, physical distribution and promotion. Although small-scale farmers have limited possibilities to deal with these topics, the topics are often discussed vividly.

One should know to whom and in which places one will sell one's product as soon as, or even before, building a mushroom farm, be it a simple barn or a more sophisticated construction.



Figure 28: Selling mushrooms on the marketplace

That means that one will have to explore in advance who the customers are and where to find them.

For instance:

- Marketplaces
- Delivery to door
- Tourist centres and hotels
- Shops and/or supermarkets

Specific demands

One should realise that each customer group has specific demands with regard to products, prices and delivery.

Supermarkets

The past few years the percentage of households that buy mushrooms at the local market and at the greengrocer's has diminished. In Western Europe and the USA, supermarkets play a predominant role as sales channels for mushrooms. Most households (90%) buy at supermarkets; a trend that is likely to develop similarly in parts of Africa and Asia. This means that presentation of the product and proper packaging become increasingly more important

Market and market channel

Small-scale growers should focus on the local markets. Export markets are far too complicated, even when they join forces and cooperate with each other.

It is important to know what is happening on local markets.

Three points are to be observed:

- what is the demand,
- who are the suppliers and
- what are the prices paid for the various products.

With this knowledge choices can be made about the type of mushrooms to be grown, location, transport to the markets, packaging and presentation of the products. Who are the customers and what are they interested in.

Middleman or farmer group

Choices also have to be made about selling to supermarket(s) through a middleman or jointly through a group of small-scale growers. Most likely the middleman will pay directly whereas most supermarkets have a delay in payment of a few weeks.

Marketing plan

All these points can be laid down in a marketing plan. The more information is available the better decisions can be made. Calculating the cost price is most vital; when the cost price is higher than the market price it is not beneficial to cultivate these mushrooms. An interesting point in this calculation of the cost price is the cost of labour. It makes a big difference if the small-scale grower can do this activity in his spare time or whether he has to hire labour to do the job for him.

Further reading

The Cultivation of Mushrooms, 1988, edited by van Griensven; English edition: Darlington Mushroom Laboratories Ltd. Price: approximately US\$ 25, available at CCO, Horst, the Netherlands

All the aspects of *Agaricus* production around 1987 in The Netherlands are treated extensively. The situation in The Netherlands has changed since then, but the book remains valuable for its in depth treatment of all aspects of mushroom growing. The chapters on breeding, spawn production, compost preparation, organisation, and climate control are of interest to *Agaricus*-growers all over the world.

Edible and poisonous mushrooms of the world, 2003, New Zealand Institute for Crop and Food Research, by I. Hall e.a.

ISBN 0-478-10835-4

370 pages of general information on mushrooms: which wild mushrooms to pick, how to grow them, poisonous mushrooms of the world, with 250 high quality colour pictures.

Mushrooms: cultivation, nutritional value, medicinal effect, and environmental impact, 2004, by S. T. Chang and P.G. Miles. Boca Raton, Fl (etc): CRC Press. US\$ 159.95.

ISBN 084931043

This book contains the latest cultivation and “techno biological that contribute to the modernization of the mushroom farming. It presents the individual steps of the complex mushroom cultivation process, not only the “how but also the “why” is explored.

The Mushroom Cultivator. A practical guide to growing mushrooms at home, 1983, P. Stamets and J.S. Chilton, Agarikon Press, Olympia, Washington. Price: approximately US\$ 35.

ISBN 0 9610798-0-0

Good descriptions of sterile techniques spawn production, compost preparation, and a key to common contaminants in agar cultures. Specific information on tropical mushrooms is limited, but the book pro-

vides a good overall view of many aspects of mushroom production, including that of hallucinogenic Psilocybin and Agaricus.

Mycelium running: how mushrooms can help save the world, by P.Stamets, Berkeley, CA:Ten Speed 2005. US\$ 35
ISBN 1580085792, ISBN9781580085793.

A comprehensive guide which capitalises the digestive power of mycelium and unveils new methods for growing mushrooms. Has chapters on nutrition, medicinal properties, log and stump culture and natural culture, using easy to use and low-tech techniques, and much more. In total, 28 species are fully described. Heavily referenced and beautifully illustrated.

La culture des champignons, J.M. Olivier e.a, 1991.
ISBN 2-200-37242-6

This French pocketbook describes the cultivation of *Agaricus bisporus*, *Pleurotus* spp, *Lentinula edodes*, *Lepista nuda*, *Stropharia rugoso annulata*, and discusses truffle cultivation together with host trees.

An introduction to the larger fungi of South Central Africa, 1994
by L. Ryvarden, G.D. Pearce and A.J. Masuka. Published by Baobab, Zimbabwe. ISBN 0-908311-52-4

A guide to the most common edible and poisonous mushroom species in Malawi, Zambia and Zimbabwe. 200 pages, coloured pictures. Contains more information than Edible mushrooms of Tanzania.

Mushroom Cultivation, Appropriate technology for mushroom growers, third edition, by Peter Oei, Backhuys Publishers, Leiden The Netherlands. Also available from CTA = no. 1146, 40 credit points. ISBN 90-5782-137-0

Useful addresses

ASEMM

African Society for Edible and Medicinal Mushrooms

E: info@asemm.org

Christiaens Group

Witveldweg 104-106-108, 5961 ND Horst, The Netherlands

T: + 31 77 399 9500, E: hvousten@christiaensmachines.com

F: +31773999561, W: www.christiaensgroup.com

The Christiaens Group consists of 3 divisions: Construction, Controls and Machines. The Christiaens Group is setting up turnkey projects on Mushroom Cultivation as well as on Waste Management worldwide.

Within the Group there is a long experience in the fields of Building Construction, Construction of Machinery and Control Systems. Not only turnkey projects are important but also small-scale projects are given adequate attention.

CNC

Postbus 13, 6590 AA Gennep, The Netherlands

T: + 31 (0) 485 51 6541, F: + 31 (0) 485 51 7823

E: info@cnc.nl, W: www.cnc.nl

A large number of the Dutch mushroom growers is associated in the Coöperatieve Nederlandse Champignonkwekersvereniging U.A. Its cornerstones are the production of full-grown compost and casing soil for the cultivation of mushrooms through CNC Grondstoffen B.V. and the canning of mushrooms through Lutèce B.V.

C Point

P.O.Box 6035, 5960 AA Horst, The Netherlands

T: +31 77 3984555, F: + 31 77 3984160

E: info@cpoint.nl, W: www.cpoint.nl

C Point, Training and Consultancy for mushroom growing; trains and advises mushroom growers and their employees in all aspects of mushroom cultivation.

Gicom b.v.

Oostweg 9, 8256 SB Biddinghuizen, The Netherlands

T: + 31 (0) 321 332682, F: + 31 (0) 321 332784

E: info@gicom.nl , W: www.gicom.nl

Gicom Composting Systems constructs all features/facilities for mushroom cultivation such as compost yards, tunnels and growing houses. All climate control equipment is manufactured, delivered and installed by Gicom Composting Systems too. Apart from GCS manufacturing installations for Waste Treatment, Air Purification and Biological Drying. All machines and process control systems for these installations are manufactured as well.

Hoving Holland

P.O.Box 9, 9500 AA Stadskanaal, The Netherlands.

T: + 31 599 613390, F: +31 599 619510

E: info@hoving-holland.nl , W: www.hoving-holland.nl

Hoving Holland is manufacturer of machinery and composting systems for the mushroom industry and exports to many countries. In addition they construct equipment for organic waste disposal. They are among the distinguished leading suppliers of global turnkey projects.

ILEIA

Centre for Information on Low External Input and Sustainable Agriculture. Promotes exchange of information for small scale farmers in the South through identifying promising technologies. Information about these technologies is exchanged mainly through the LEISA Magazine. All articles accessible on-line.

Contact: ILEIA, Zuidsingel 16, 3811 HA Amersfoort, The Netherlands

T: +31(0)33-4673870, F: +31(0)33-4632410

E: ileia@ileia.nl, W: www.leisa.info

International society for mushroom science

ISMS Secretary

PO Box 11171, Centurion, Pretoria 0046, South Africa

T: +27 12 665 2210; F: +27 12 665 2212

E: secretary@isms.biz, W: www.isms.biz

Lenssen Vul- en Sluittechniek b.v.

P.O.Box 6848, 5975 ZG Sevenum, The Netherlands

T: + 31 77 4672157, F: +31 77 4673775

E: lenssen@lvs-bv.nl, W: www.lvs-bv.nl

LVS provides machines and complete production lines in the area of food processing. Used and new machines and complete production lines are utilised for suitable and custom-made solutions. Worldwide assembly, commissioning and service. Highly experienced in mushroom processing.

Mushroom Business

Reed Business Information bv.

P.O. Box 16500, 2500 BM The Hague, The Netherlands

T: +31 (0)70 441 5060, F: +31 (0)70 441 5902

www.mushroombusiness.com

Mushroom Business is a two-monthly, international trade journal for the worldwide mushroom industry (growers and suppliers). It features articles on growing techniques, markets and marketing, cultivation tips, research, industry news, opinion, and more. The site of Mushroom Business has links to the major suppliers of mushroom equipment, training etc.

Mushworld: www.mushworld.com

Non-profit organisation devoted to poverty alleviation in the world through mushroom growing, especially in developing countries.

Mycelia

Veldeken 38, 9850 Nevele, Belgium

T: +32 (0) 9 228 7090; F: + 32 (0) 9 228 8928

E: info@mycelia.be , W: www.mycelia.be

Mycelia produces mother cultures, mother spawn as well as final spawn in a wide range of edible and medicinal mushrooms. Advises and Training on Spawn production technology are given on demand. Mycelia produces autoclavable and gas permeable Micro sacs® for fermentation processes as well as sterilized, gas permeable Micro boxes® for the propagation of plants.

PUM, Netherlands Senior Experts

P.O. Box 93078, 2509 AB The Hague, The Netherlands

T: (+31) (0)70 349 05 55, F: (+31) (0)70 349 05 90

E: info@pum.nl, W: www.pum.nl

PUM sends senior experts to more than 70 countries in Africa, Asia, the Middle East, Latin America and Central and Eastern Europe. Upon request, PUM's experts offer their skills and experience to businesses and organisations in places where these are most needed. In the course of their careers, PUM's advisers have gained extensive experience in nearly every conceivable field. These experts are independent and work on a voluntary basis (they receive no wages).

Scelta BV

Heymansstraat 35, 5927 NP Venlo, The Netherlands

T: +31 77 324 10 20, F: + 31 77 324 1029

E: Sales@sceltamushrooms.com, W: www.sceltamushrooms.com

Scelta Mushrooms is responsible for the sales and marketing of (frozen) mushrooms of several partner companies to customers around the globe. Scelta has a production unit for "added-value" mushroom products as breaded mushroom snack or pre-fried mushrooms to be used as a component in ready-made meals. In cooperation with a partner company Scelta produces mushroom flavour products in powder and liquid form to be used by the food industry.

Spore Mushroom Products / Stichting ECO Consult

Gargouille 1, 4007 RE Tiel, Netherlands

T: + 31 (0)6 515 42 882, F: 0344 630 225

W: www.spore.nl Information on special plastic bags for spawn production and on international training activities. E-mail for training courses to info@spore.nl.

World Mushroom Society: www.worldmushroomsociety.com

The objective of the WSMBMP is to promote knowledge related to mushroom biology and mushroom products.

W: www.fungitec.com, Website in English and Spanish

Advisory, workshops, short courses and mushroom projects.

Appendix 1: Formulas

Formulas for media

PDA: Potato Dextrose Agar extract medium

200 g diced potato, 20 g agar powder, 20 g dextrose or ordinary white cane sugar, 1 litre water.

Compost medium

300 g dried compost (pasteurised) in 4 litres of boiling water.

After 15 minutes filter the water and add water until you have 4 litres again.

Then, add 10 gram of agar per litre of water

Malt Agar

0, 4 litres brewery malt solution.

0, 8 litres water

15 grams agar.

Formulas for spawn substrate

Grain spawn substrate

Grain in small containers can be moistened to a higher degree than grain in 15 litre bags.

For 2 litre containers, use the following recipe:

400 g rye, sorghum or wheat, 400 ml water, 2 g gypsum (45% moisture).

Appendix 2: Air quality test

Choose a horizontal surface, centrally located in the room where you wish to test the air quality.

Open a Petri dish with test medium, i.e. agar with nitrogen- and carbon-source, and put the lid upside down next to the Petri dish, making sure not to touch the agar surface.



Sampling period:
clean room area: 1 hour
workshop area: 10 minutes

Close the Petri dish with adhesive tape and place it in a warm room (20 à 25 °C) for incubation.

After 3 to 4 days you can analyse the results.

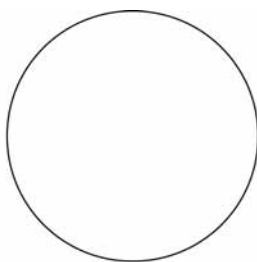

virginal dish
no moulds nor
bacteria have reached
the dish

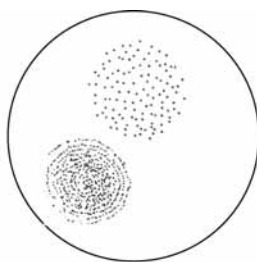

**filamentous spots, forming
black, green or coloured
spores:** each one originating
from 1 mould spore

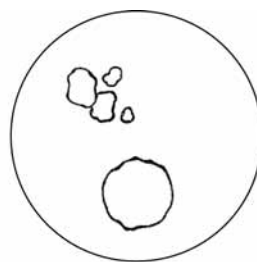

gleaming colonies
each one originating
from 1 bacterium

Courtesy of Mycelia

Appendix 3: Different origins of contamination

Quality control

Quality control in spawn manufacturing includes:

- constant inspection of the inoculated containers and
- maintaining a strict hygienic regime.

Unhygienic conditions

Unhygienic conditions during inoculation may give rise to a variety of different fungal contaminants.

Remove and pasteurise/sterilise the contaminated containers and open and clean them only after pasteurisation/sterilisation.

Insufficient sterilisation

Insufficient sterilisation often leads to outbreaks of bacteria and/or unwanted fungi

- greasy appearance on grain spawn

Improper storage

Improper storage refers to spawn that has not been stored properly (i.e. too warm or too cold), or when substrate in the containers has dried out

Storage and purity

Good spawn shows vigorous growth and contains no other organisms. If the storage period has been too long, its vigour will be diminished.

Opened containers with spawn

Opened containers with spawn should be removed immediately from the growing site after usage and should under no circumstances be reused. Do not use half a bottle because contaminants will spoil the rest of the spawn.

Infestation

Infestation can occur without visible signs (of contamination) at the beginning of the infestation.

Refrigerated spawn

Refrigerated spawn can be kept for up to six months after complete colonisation of the substrate.

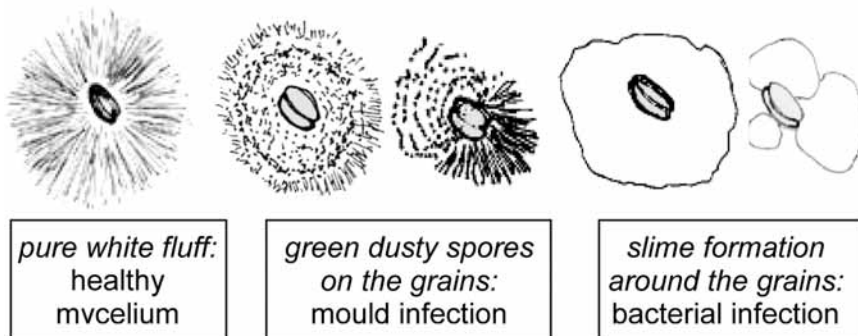

Courtesy of Mycelia

Appendix 4: Culture transfer in detail

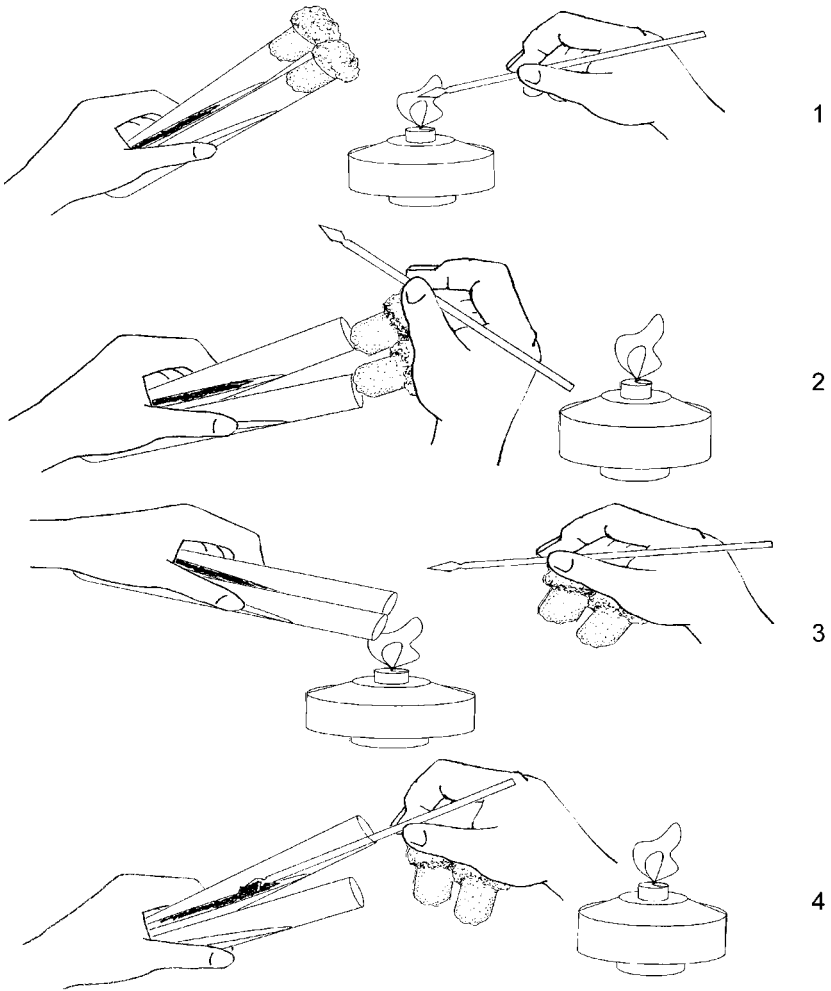

- 1 Sterilise the scalpel in the flame until red-hot.
- 2 Take the cotton plugs out of the test tubes and keep them in hand (meanwhile the scalpel has the time to cool down).
- 3 Keep the mouth of both test tubes above the flame.
- 4 Cut a small square (5 x 5 mm) from the « mother » test tube culture.

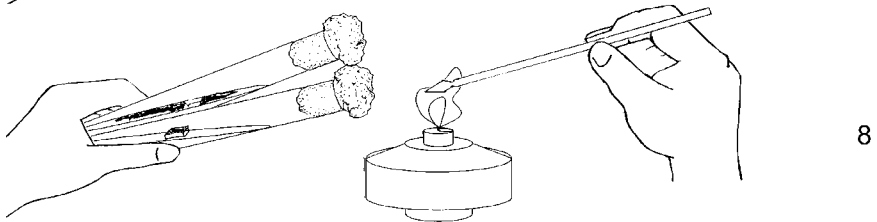
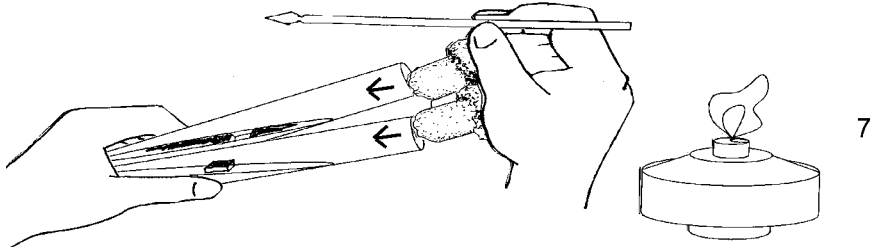
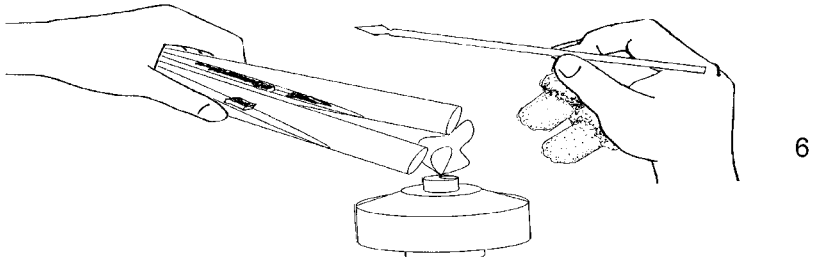
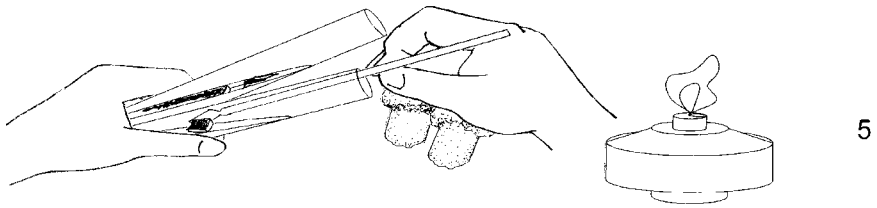

- 5 Put the square in the middle of the agar surface of the new test tube.
- 6 Reheat the mouth of both test tubes in the flame for 3 seconds.
- 7 Replace the cotton plugs.
- 8 Sterilise the scalpel in the flame once more and repeat the procedure for the next transfer.

Appendix 5: Formulas for compost

Compost formulas for Button Mushrooms (*Agaricus* spp)

Formula 1

1000 kg straw rich stable manure or straw mixed with chicken manure thoroughly mixed with 10 kg of chalk.

Water is added until it leaks out the pile.

Formula 2 (to be used if no manure is available)

Straw	1000 kg
Urea	10 kg
Ammonium sulphate	20 kg
Potassium sulphate	8 kg
Calcium carbonate	25 kg

Compost recipe bagasse (weight percentages)

Rice straw	35%
Sugar cane bagasse	33%
Chicken manure	25%
Gypsum	5%
Soybean meal	2%
Urea	1%

Compost formulas for Rice Straw Mushrooms (*Volvariella* spp) in weight percentages

Formula 1

Paddy straw	14-28%
Cotton waste	25-45%
Sugar cane waste	12%
Cotton waste/paddy straw mixture	22%

Formula 2

Rice straw	45%
Cotton waste	40%
Rice bran	10%
Lime	5%

Formula 3

Dry cotton waste	90-92%
Rice bran (supplement)	4%
Limestone (pH regulator)	4-6%

Formula 4

Cotton waste	50-75%
Rice straw	25-50%
Limestone	3-4%

Formula 5

Spent substrate from Agaricus cultivation	50%
Cotton waste	50%

Formula 6

Chopped water hyacinth	50%
Rice straw	50%

Formula 7

Rice straw	40%
Sugar cane waste (bagasse)	29%
Chicken manure	29%
Gypsum	2%
Dash of urea	about 0.1%

Appendix 6: Simple steaming systems

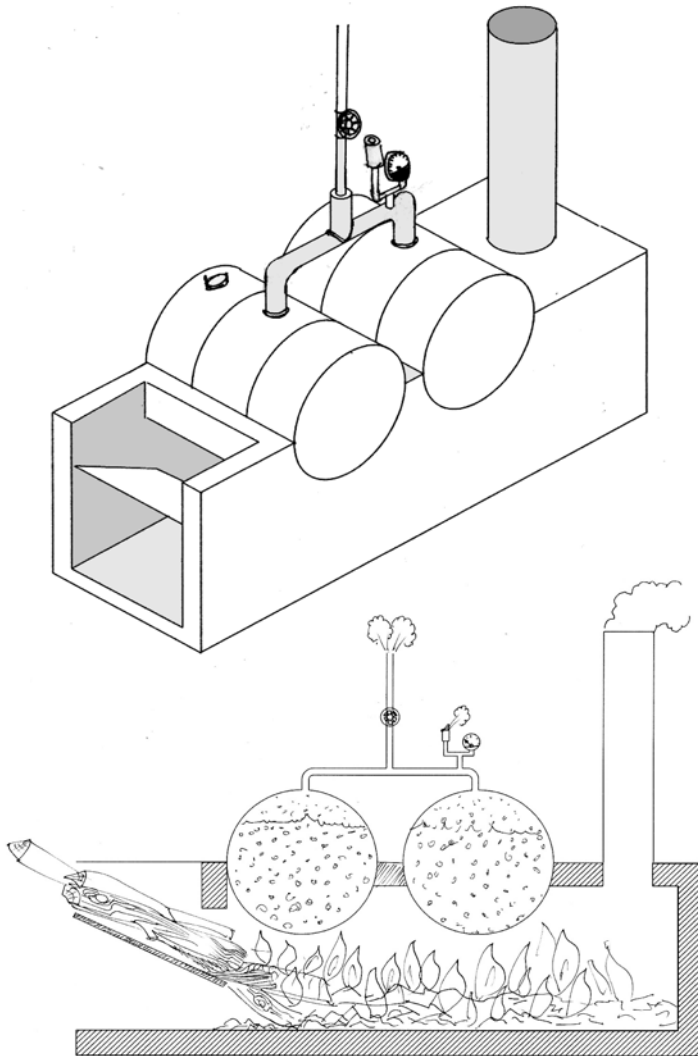

Figure 29: Oil drum steaming system and cross section

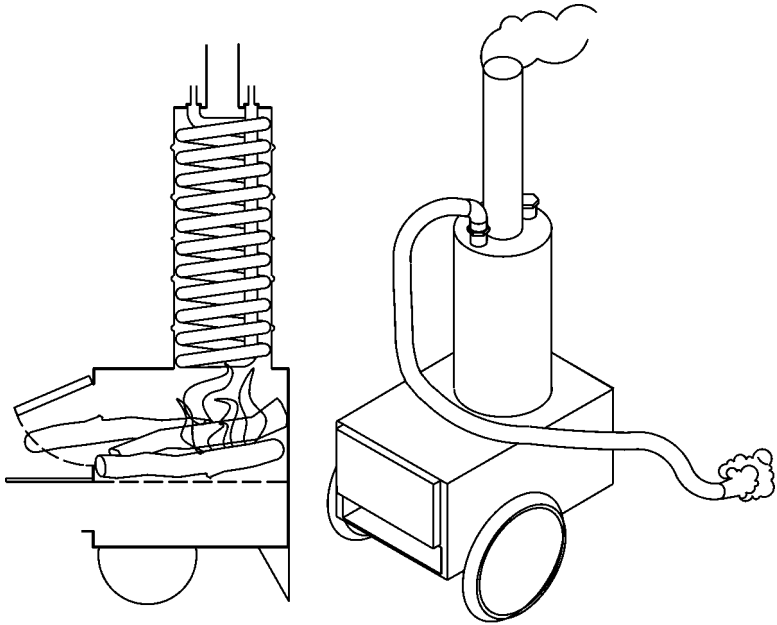

Figure 30: Mobile steaming system and cross section

Glossary

Actinomycetes:	White filamentous organisms (sometimes similar to fungal hyphae), which occur in well-fermented compost, indicating that the compost is suitable for cultivation of <i>Agaricus</i> spp.
Air lock:	Enclosed section with gates at each end in order to prevent outside air entering directly the growing room.
Agar:	An extract from a seaweed used to solidify media: alternatively, (cheaper) gelatine may be used. Agar is available in bar or powder form.
Anaerobic:	Without oxygen (O ₂).
Aseptic:	Sterile condition: no unwanted organisms present.
Autoclave:	A container or any form of pressure cooker in any dimension (small or big) the contents of which can be heated up to 121 °C. It must be able to withstand an overpressure of 1 bar; otherwise the temperature cannot rise sufficiently.
Bacteria:	Microorganisms that may cause contamination in culture work. Grain spawn is very easily contaminated with bacteria.
Break:	See flush
Button stage:	The young mushrooms are still fully closed.
Cellulose:	An organic compound in wood, straw, etc. It is easier to degrade than lignin. Cellulose is probably best known as raw material to make paper. Cotton waste contains high amounts of cellulose; sawdust contains cellulose, hemi-cellulose and lignin.
Conditioning	Gradual lowering of the temperature within one or two days in order to get rid of the free ammonia in the compost.
Culture:	See mother culture.
Culture medium:	Microorganisms differ in their nutritional needs. A large number of different media have been devel-

	oped; PDA-agar and Malt-agar can be used for most cultivated mushrooms.
Fermentation:	The process of composting. Easily accessible nutrients will be degraded by microorganisms that make the substrate more selective. Unwanted fermentation may occur if the compost is still very 'active' or if thick layers or large bags are used. In that case the temperature rise inside the substrate will become too high for the desired mycelium.
Flush:	The sudden development of many fruiting bodies at the same time. Usually there is a resting period between flushes or breaks.
Formol:	A 30% solution of formaldehyde used to sterilise areas. The gasses kill living microorganisms and spores.
Free water:	The actual water available to the microorganisms in the substrate. Water content is the absolute measure. Free water is related to the water film around each particle in the substrate and the concentration of salts in the water.
Fruiting:	The mycelium will form mushrooms in its reproductive stage. This is called fruiting as the mushrooms are actually the fruiting bodies of the mycelium.
Germination:	The spreading of hyphae from spores.
Gills:	the radially arranged, vertical plates below the cap of a mushroom on which spores are formed.
Hyphae, hyphae:	Individual cells of mycelium.
Incubation:	The period after inoculation (preferably at an optimum mycelial growth temperature) during which the mycelium slowly grows through the substrate
Inoculation:	Transferring an organism into a specific substrate.
Lamellae:	See gills
Lignin:	An organic substance that is difficult to degrade, which, together with cellulose, forms the basis of wood, straw, etc.

- Microorganisms:** Microscopic organisms which are abundantly present in the air and stick to every surface.
- (Mother) culture:** A pure strain of an edible fungus growing on a medium.
- Mother spawn:** Spawn that is not used for inoculating substrate, but for inoculating another batch of spawn.
- Mycelium:** The network of hyphae that form the vegetative body of the fungus. Mushrooms are the fruiting bodies of the mycelium.
- Mycorrhiza:** A symbiotic relationship between fungi and plant roots.
- Parasite:** Organism that lives at the expense of others, usually causing diseases in its hosts. Ultimately it may cause the death of its host.
- Pasteurisation:** Heat treatment applied to a substrate to destroy unwanted organisms but keeping favourable ones alive. The temperature range is 60-80°C. The treatment is very different from sterilisation, which aims at destroying all organisms in the substrate.
- Petri dish:** A round glass or plastic dish, with a cover, used for observing the growth of microscopic organisms. The dishes are partly filled with sterile growth medium (or sterilised after they have been filled). Petri dishes are commonly used to grow mycelium that will inoculate the mother spawn.
- Peak Heating:** Pasteurisation of the compost in the growing rooms
- Pinhead:** A term to describe a very young mushroom, when the cap is pin-sized.
- Primordium:** The initial fruiting body.
- Pure culture:** An isolated culture of a microorganism without any other microorganisms. Pure cultures are essential to the spawn production process.
- Relative humidity:** The percentage of moisture in the air compared to the maximum amount of moisture that the air can contain at a given temperature and pressure.

Saprophytes:	fungi that break down complex organic structures of plants and animals in order to feed on them
Saprophytic mushrooms:	e.g. <i>Agaricus</i> spp and <i>Volvariella</i> spp.
Stem:	stalk of a mushroom
Slant:	A test tube with growth medium, which has been sterilised and slanted in order to increase the surface area.
Spawn:	Mycelium growing on a substrate used as planting material in mushroom cultivation.
Spawn run:	The period of vegetative growth of the mycelium throughout the substrate after spawning.
Species:	Fundamental unit of biological taxonomy. Generally speaking, two individuals belong to the same species if they can produce fertile offspring.
SMS:	Spent Mushroom substrate, the substrate remaining after the mushrooms have been harvested.
Spores:	The means of reproduction in fungi. In cultivated mushrooms they are formed on the gills and dispersed in the air. One mushroom can produce millions of spores.
Sterile:	Conditions: see aseptic.
Sterilisation:	Destroying (completely) all microorganisms present, by heat. Spawn substrate always has to be sterilised prior to inoculation.
Stipe:	Stalk of a mushroom.
Strain:	A group of individuals within a species. Equivalent to “race” or “variety” in plants.
Subculture:	A culture derived from another culture.
Substrate:	the material in which the mycelium grows.
Taxonomy:	Science of classification of living things
Test tube:	A tube of thin, transparent glass closed at one end used in chemical and biological experiments.
Tissue culture:	A culture made from the tissue of a young and healthy mushroom.
Veil:	Layer of tissue that completely surrounds the baby mushroom.