



Protecting lives and assets



Rappbomek.com



Technology as a competitive advantage

“Use of AI (Agents)”



“Use of 3D printing”

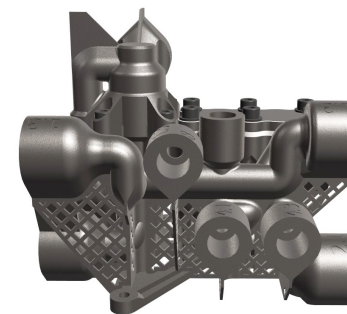
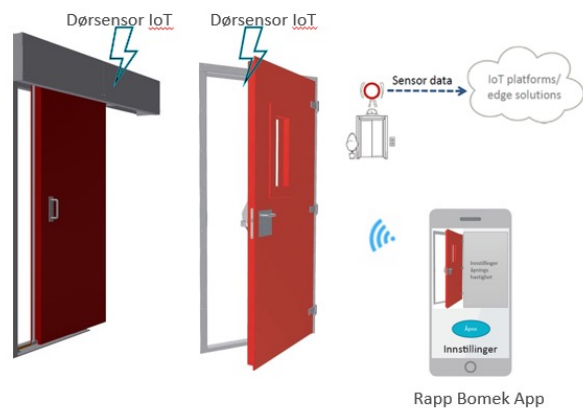

New factory in Bodø – Sustainable production - Robot

- New production line (3,500 sqm)
- Highest energy rating (Class A), seawater heat pump for heating Solar panels for on-site power generation and a new energy-efficient machine park
- New robotic production line
- Total investment: approx. NOK 120 million
- Annual production capacity increased by 200%
- State-of-the-art surface treatment: sandblasting, brushing, and coating
- Production capacity of 1,200 units per year (single shift)

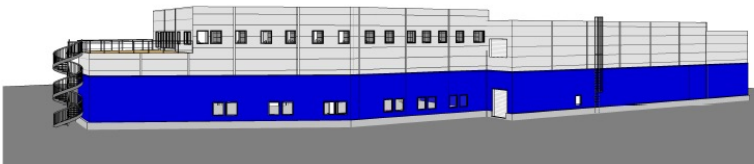

MADE IN
NORWAY



Industrial Development Project in Collaboration with Aibel and Equinor

#PåLagMed3Dprinting#

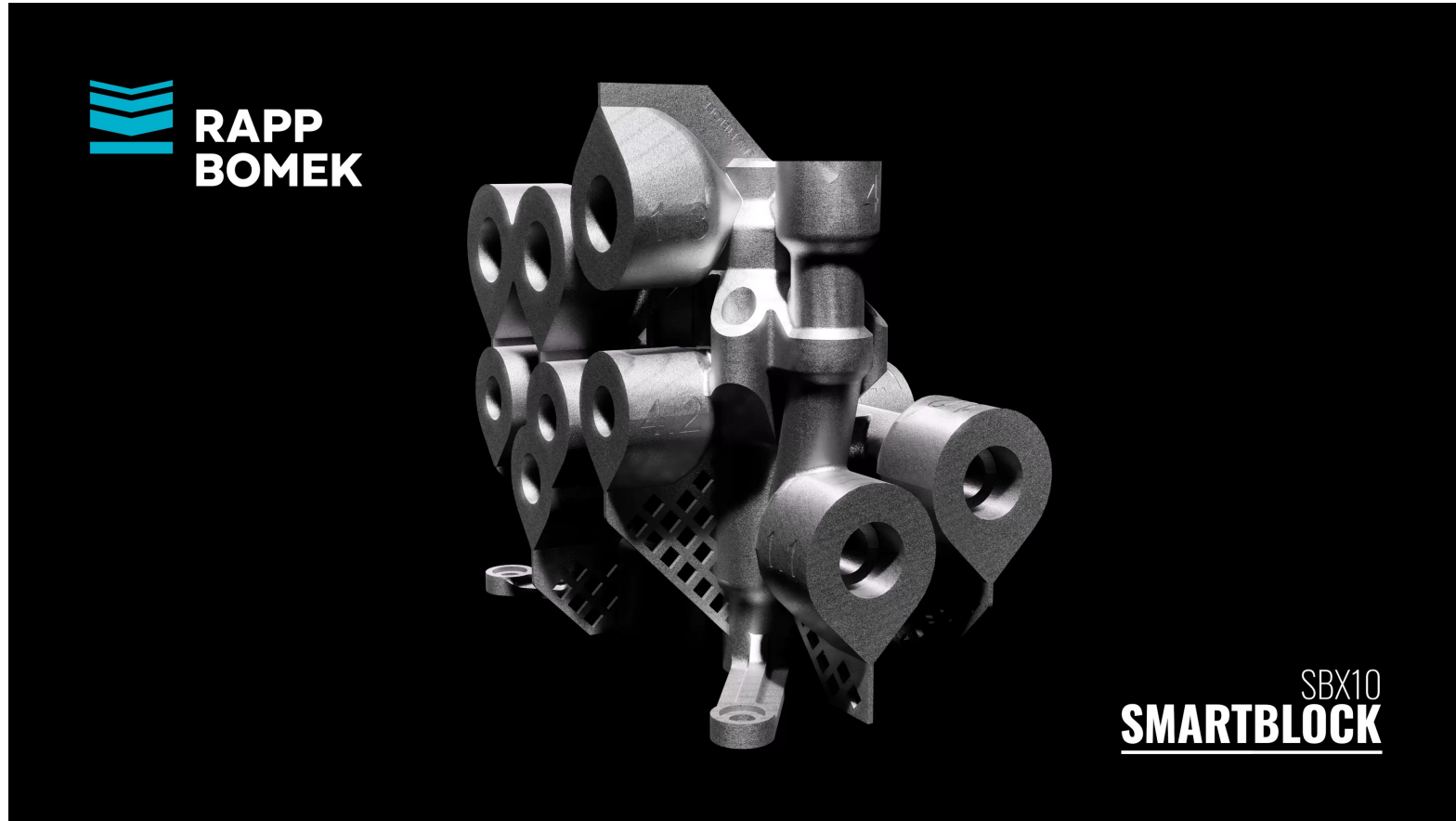

RB SBX10, New Innovative Solution for Pneumatic Drive System

Industrial Development Project in Collaboration with Aibel, Equinor, and AM North

Objective:

The goal is to develop a new drive system that simplifies installation and maintenance offshore, where parts can be 3D printed and included in a digital inventory.

Key Features:

- We aim to integrate everything into the drive system during production
- Eliminate the technical cabinet measuring 60 cm x 60 cm, which occupies significant space.
- Remove the need for an external cabinet, reduce fittings by 50%, and cut down offshore installation work by one week.
- Decrease procurement costs by approximately 25-30%.
- Reduce maintenance costs by lowering the number of parts and system complexity.
- Enhance safety



We redesigned the solution from a large technical cabinet with numerous fittings and valves to a 3D-printed solution

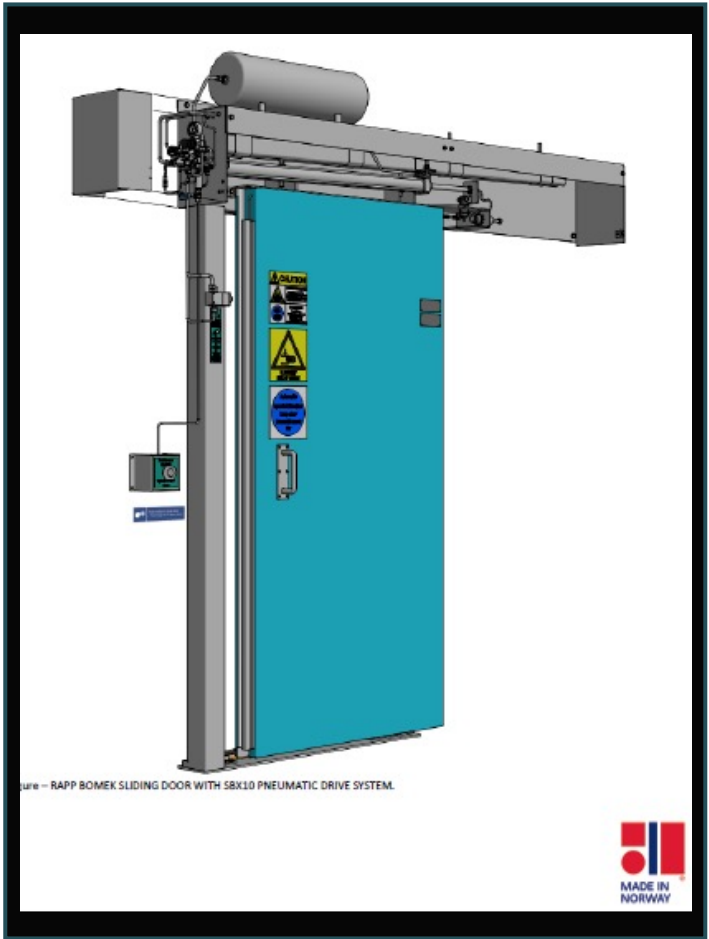
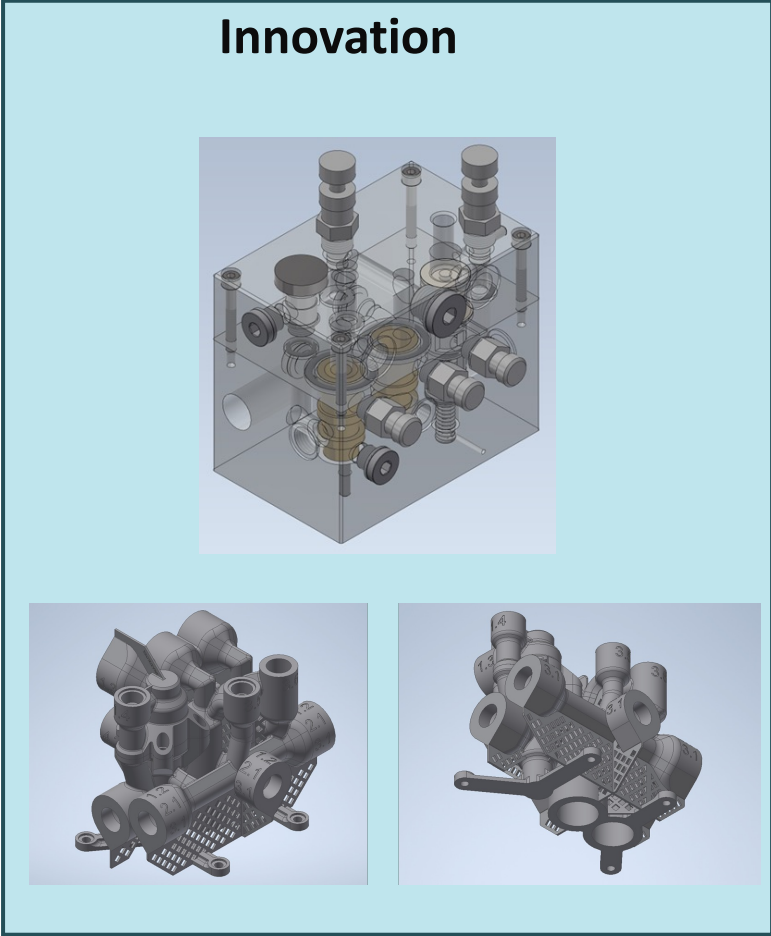

Testing and Documentation

The pneumatic drive system is defined as none critical system

Criticality Level: 0

Standard: DNV-ST-B203

Pressure Testing: 1.5 x design pressure



Test Rod: For tensile strength

Cycle Testing: with openings 3 times per minute

All Safety test: Fire safety, safety strips

Risk analysis: Risk reduction matrix

We are conducting additional tests to document that 3D printing as a production method meets the required equipment standards. TRL4 approved by Equinor

Made By:	Jan-Inge Kongsbak	Date:	08.01.2024	Revision:	1
Doc.no:	AMN-03-08-0001	Doc acc:	DNV-ST-B203		
Operator name:	Jan-Inge Kongsbak	Job Start date:	27.12.2024		
Manufacturer/comany:	AM North AS	Customer:	Rapp Bomek		
Project no.:	300164	Client ref:	SMARTBLOKK		
Preprint data preparation software and version:	Inventor Professional 2025 - V2025.1.2	Slicer software and version:	AM Studio, V2023c		
Part no. & 3D-Model:	"SMARTBLOKK V11"				
Quantity:	1stk				
Photo off build setup:					
Build plate traceability ref:	Doc: 300164-09-01 Build Traceability				
Build file ID:	1_SMARTBLOKK V11 Bunn Print_1	AM Process:	LPBF-LB		

TESTPARTNER		MECHANICAL TESTING			
Order No.	100770-00	Order No.	100770	Order No.	100770
Order date	2024-01-08	Order date	2024-01-08	Order date	2024-01-08
Order ref.	100770-00	Order ref.	100770	Order ref.	100770
Order ref.	100770-00	Order ref.	100770	Order ref.	100770

TEST RESULTS		TEST RESULTS		TEST RESULTS	
Test No.	100770-00	Test No.	100770-00	Test No.	100770-00
Material	100770-00	Material	100770-00	Material	100770-00
Length	100770-00	Length	100770-00	Length	100770-00
Width	100770-00	Width	100770-00	Width	100770-00
Height	100770-00	Height	100770-00	Height	100770-00

CERTIFICATION		CERTIFICATION	
Material	100770-00	Material	100770-00
Length	100770-00	Length	100770-00
Width	100770-00	Width	100770-00
Height	100770-00	Height	100770-00

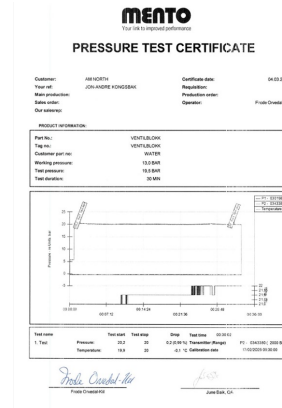

Result – New innovative 3D printed drive system for hinged and sliding doors

Functionality and Safety: We have maintained all functionalities and safety features in the solution, such as safety edges, fire safety valves, emergency opening mechanisms, etc.

Safety approved: Simplified system, easier to maintain, Fewer parts that can fail

Fittings Reduction: Reduced the need for fittings by approximately **50%**.

Digital Inventory Integration: 3D files are made available in the digital inventory.

APEX Reduction: Reduced investment by **25%**.

Offshore Installation Time: Reduced offshore installation time by approximately **3-4 days**.

Space Efficiency: Reduced the space required.

Weight Reduction: Lowered the overall weight of the system.

Complexity Reduction: Simplified the system, reducing complexity.

Reduce OPEX; Simplified system, less components



First Installation Offshore - Troll C



**MADE IN
NORWAY**



**RAPP
BOMEK**

Thank you for your attention

Kurt Kristoffersen

Mobil 93293030

E-post kurkri@rappbomek.com

