

Molly & Pollys autoværksted

Byg sjove biler af ispinde/spateler o.lign.

Til hver bilmodel kan man først se et eksempel på en færdig bil til inspiration. Siderne 1-3 (eller én af dem) kan bruges til at børnene i realstørrelse kan identificere hvilke elementer og hvilket antal, de skal bruge til at bygge bilen. Side 4 er selve byggeanvisningen til bilen. Stiplede elementer placeres bagest.

Brug fantasien og forhåndenværende materialer til hjul (f.eks. knapper, kapsler, låg, mosgummi) og pynt.

Træpindene males bedst med fingermaling før bilerne bygges.

A



A1

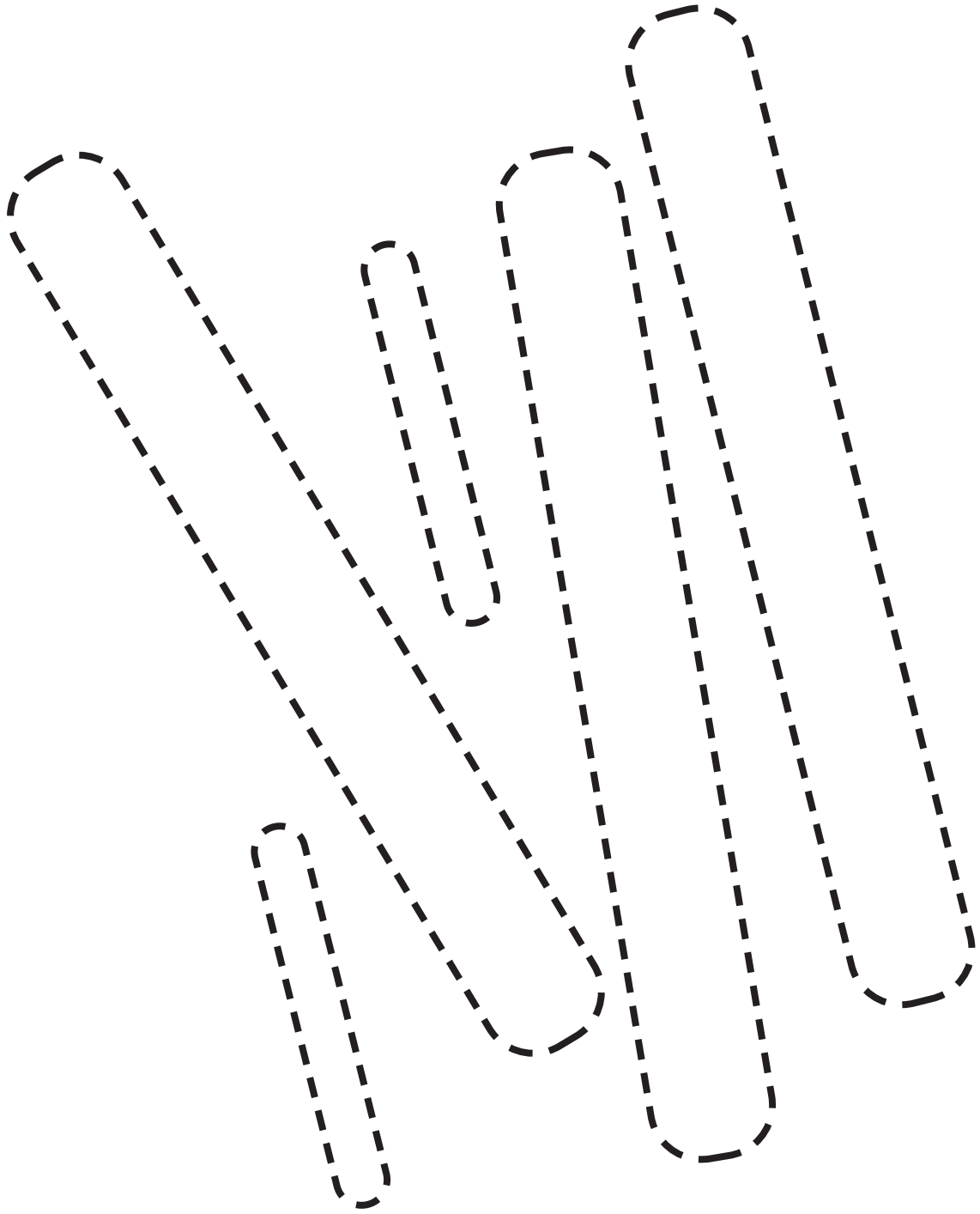

A2

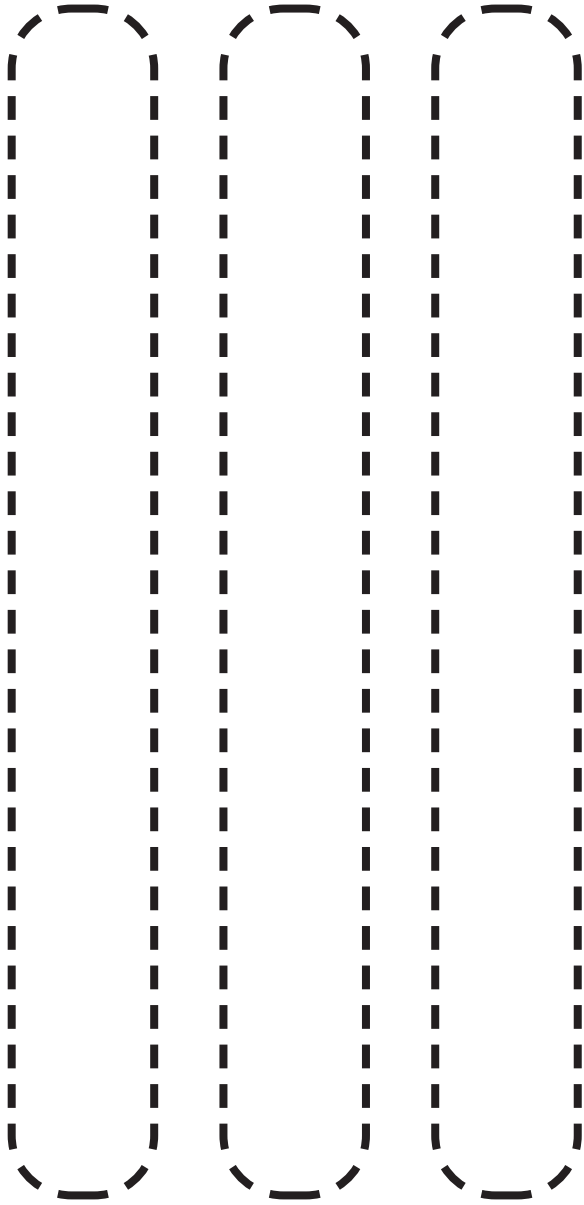

A3

3

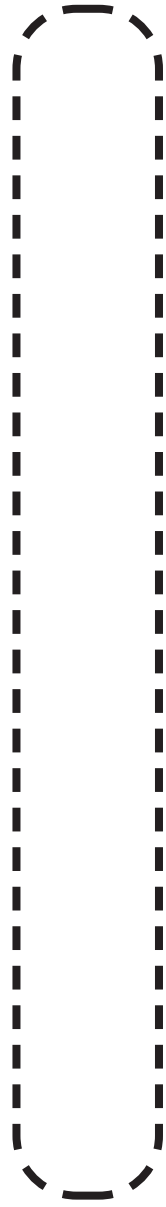

2



A4

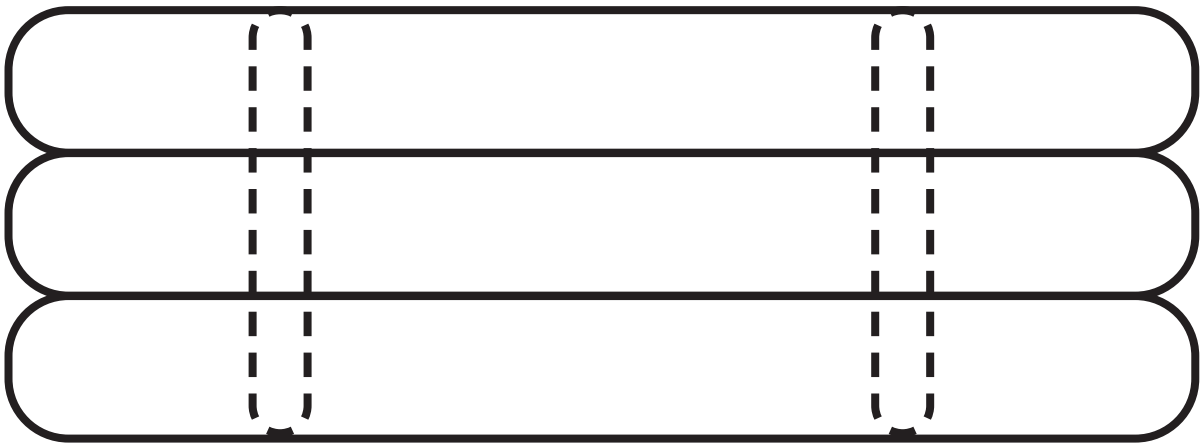

B

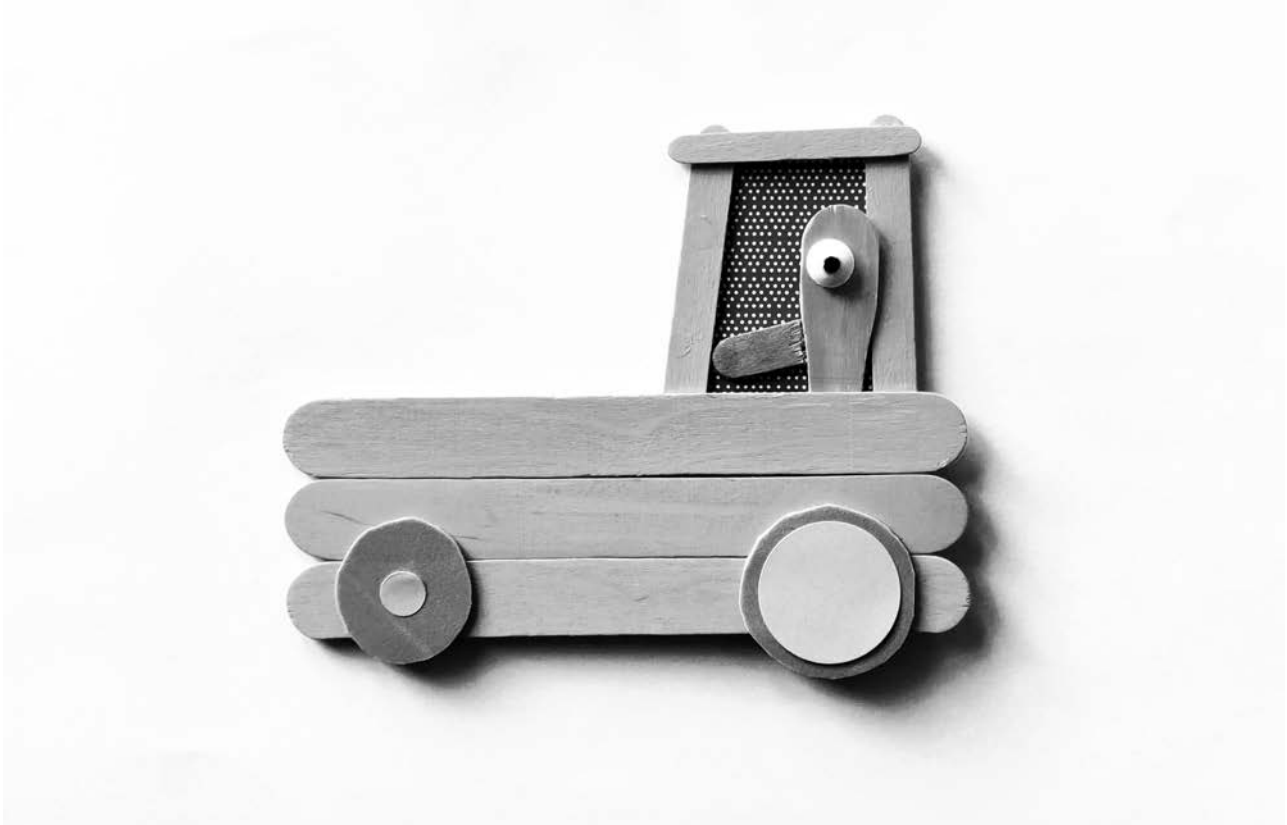

B1

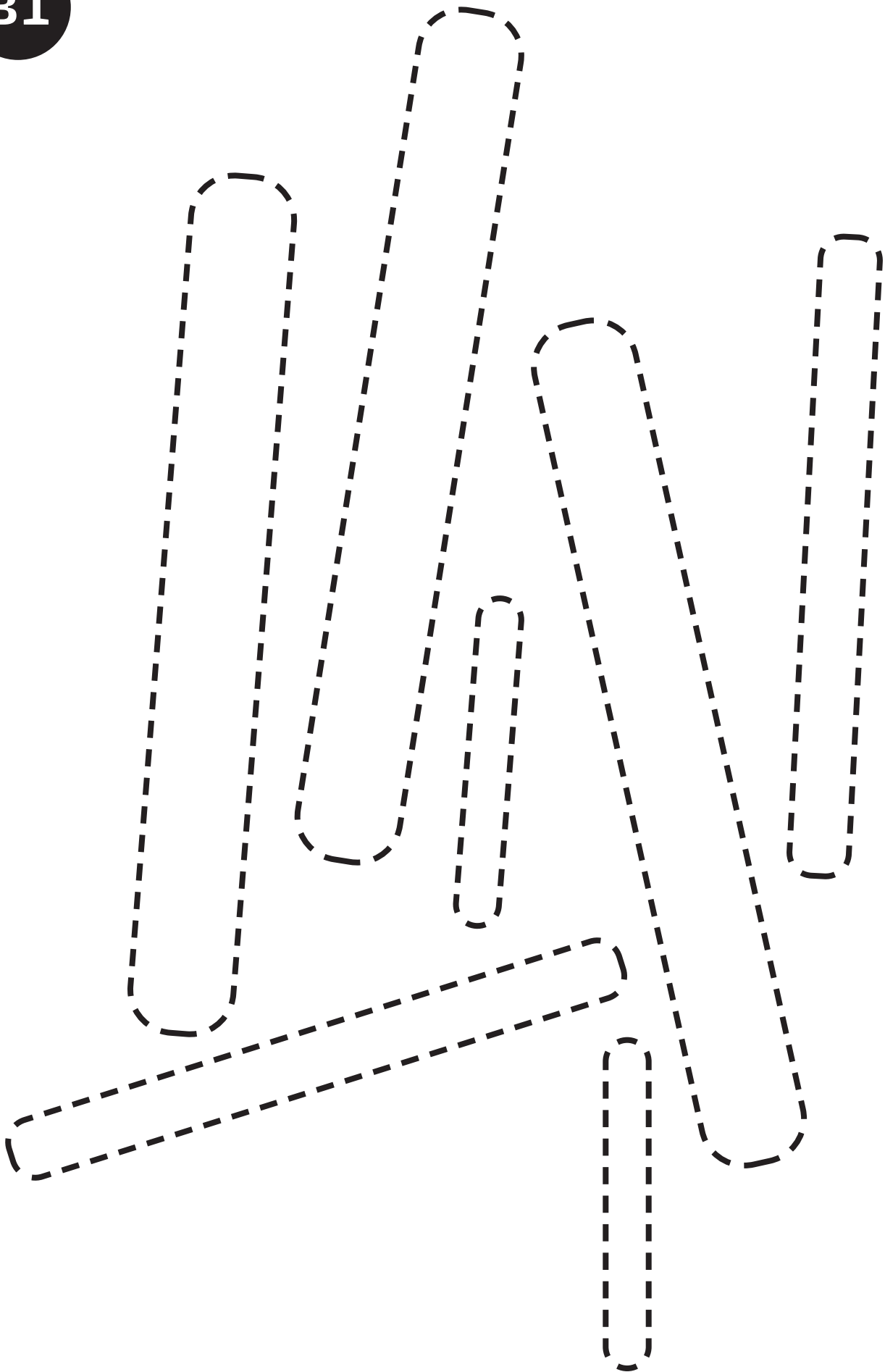

B2

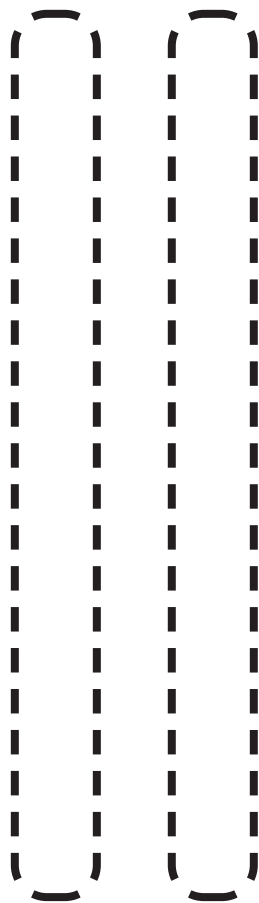
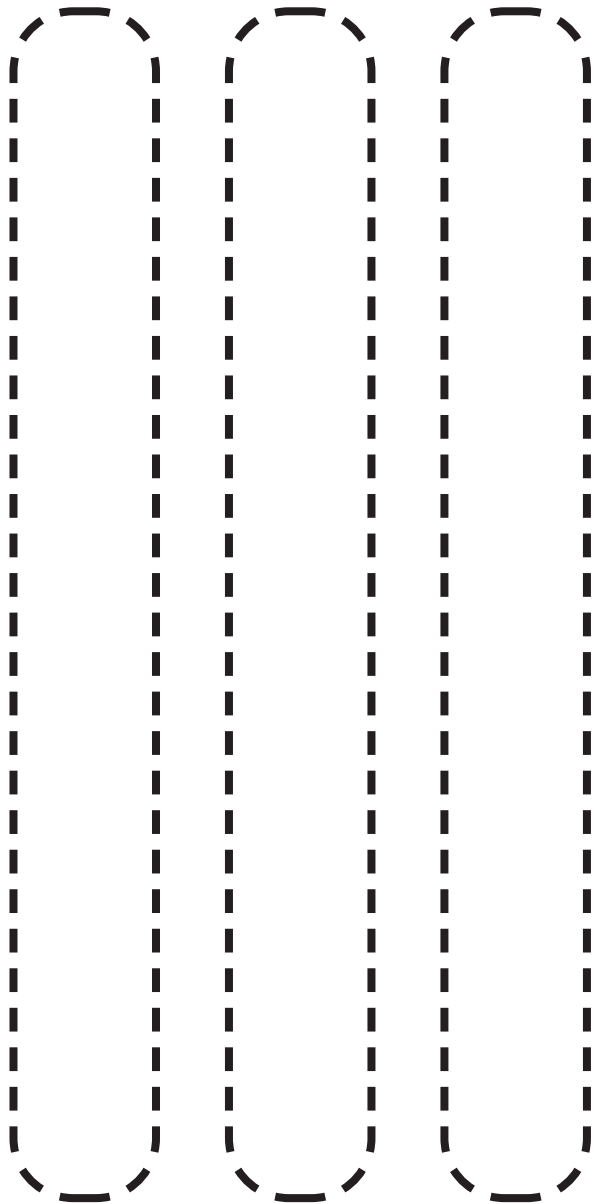

3



2



2



B4

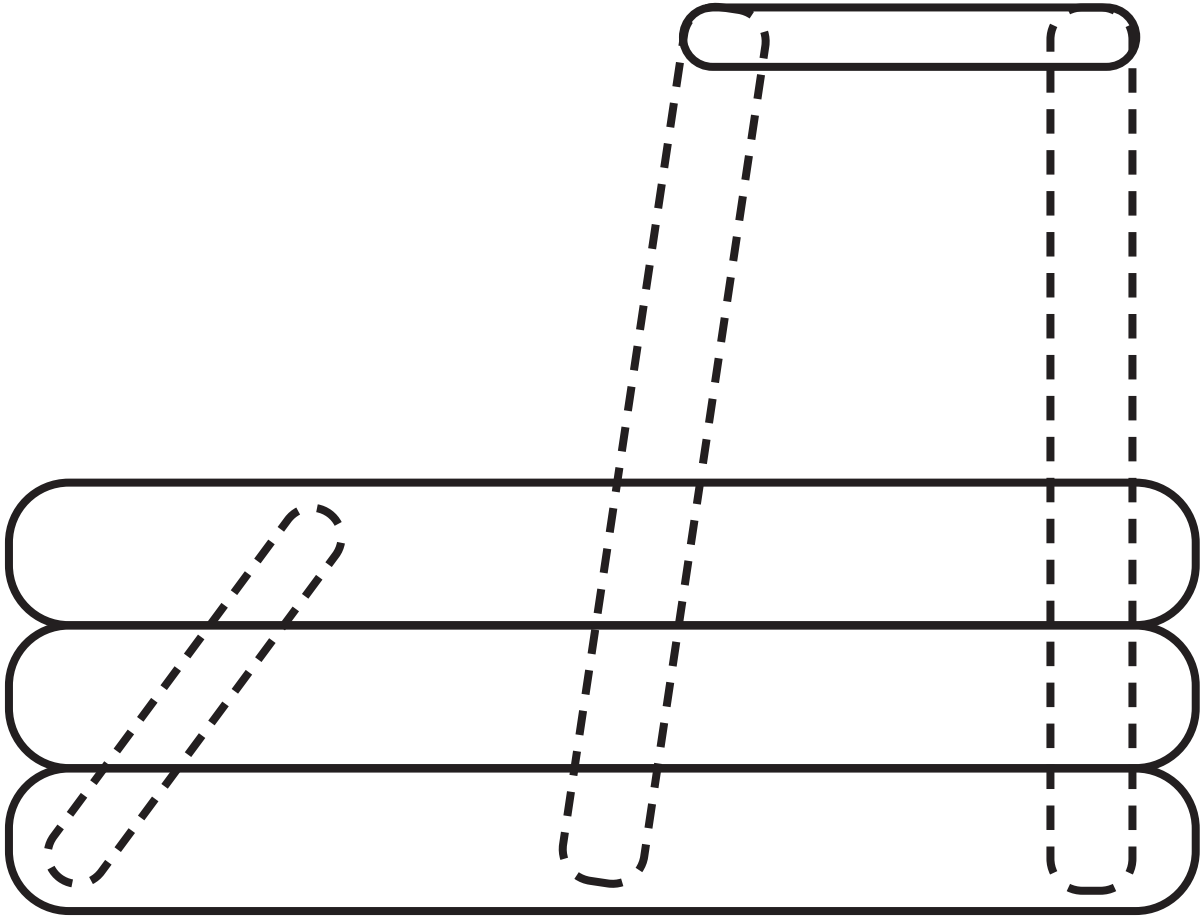

C



C1

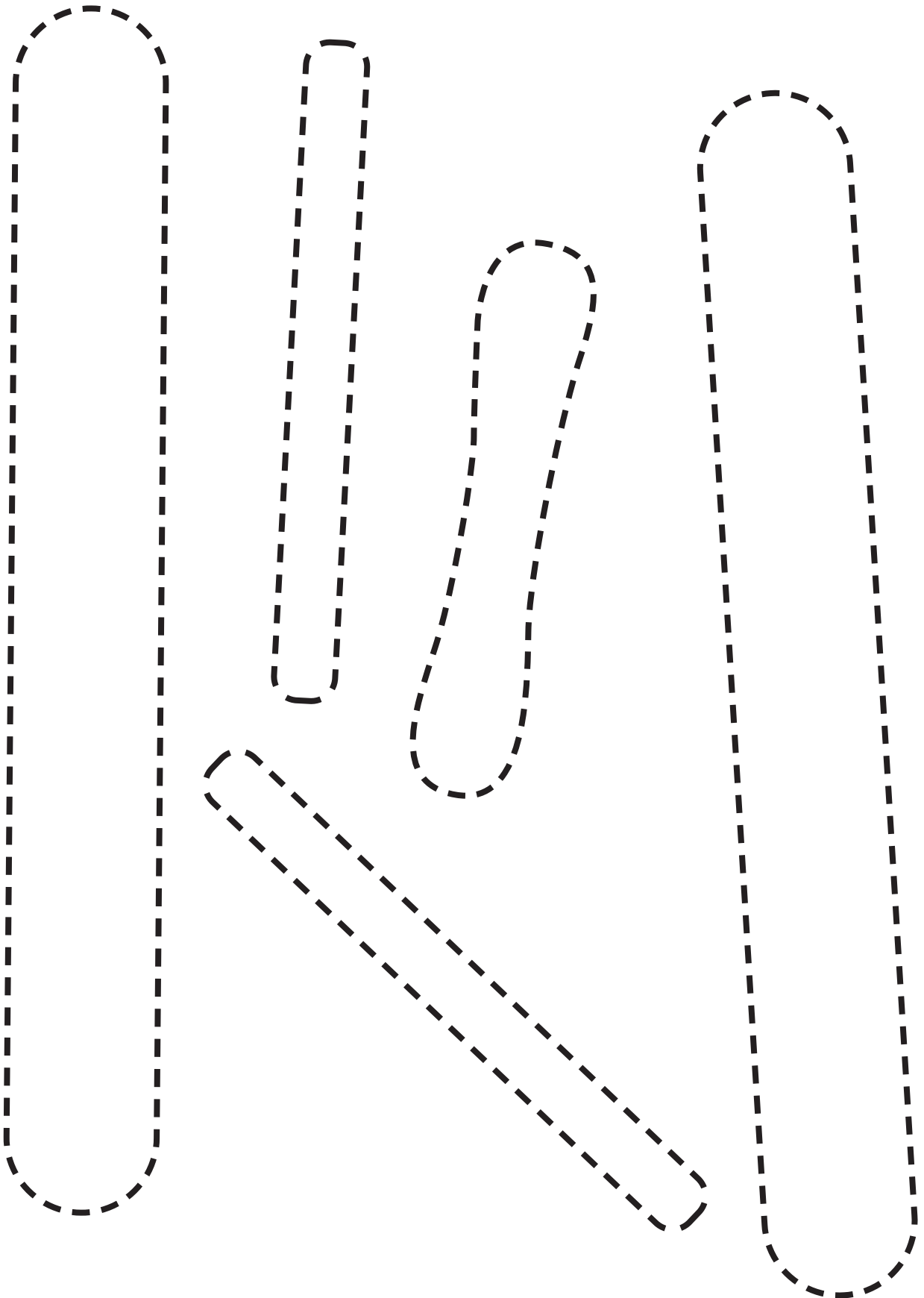

C2

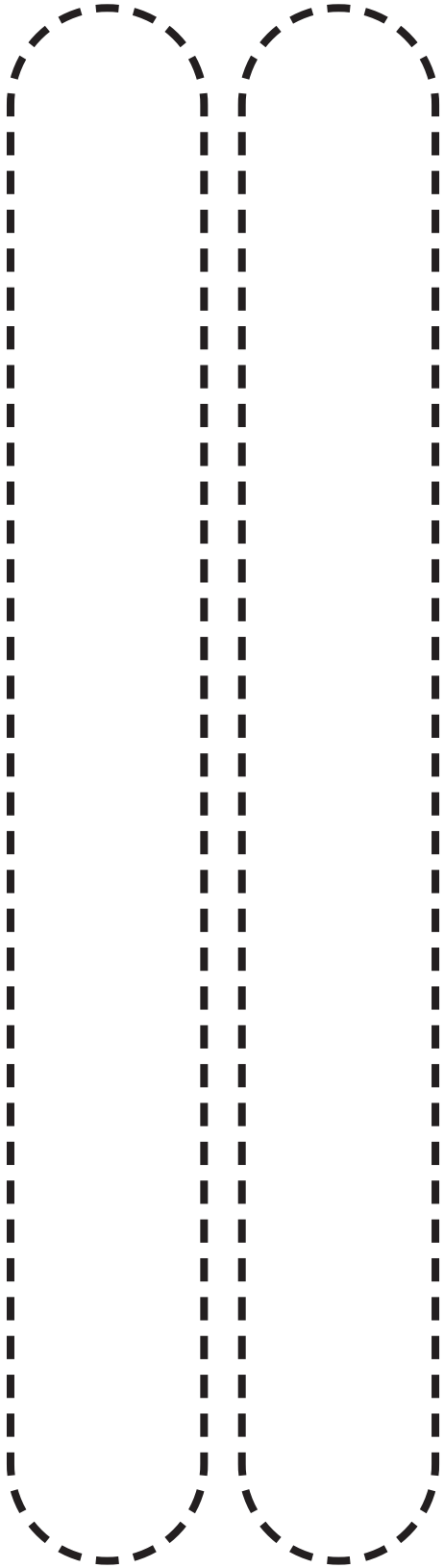

C3

2

2

1

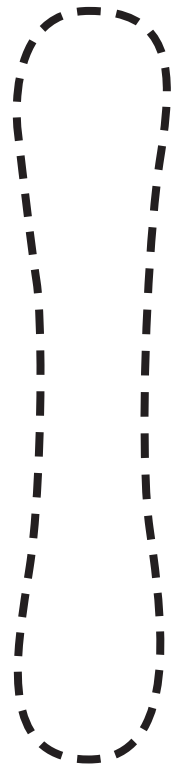
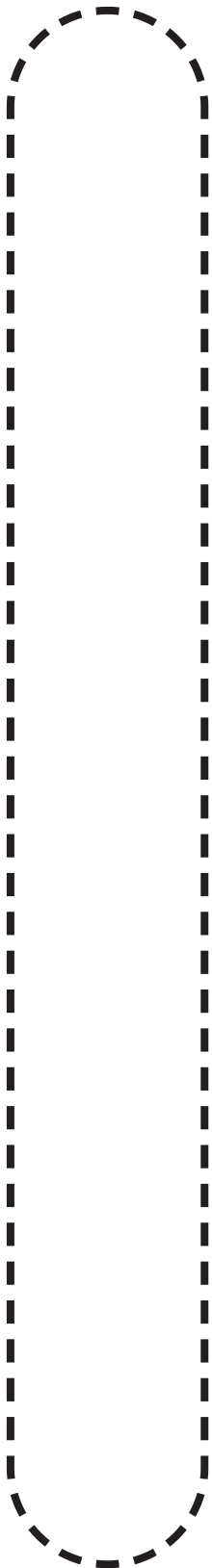

C4

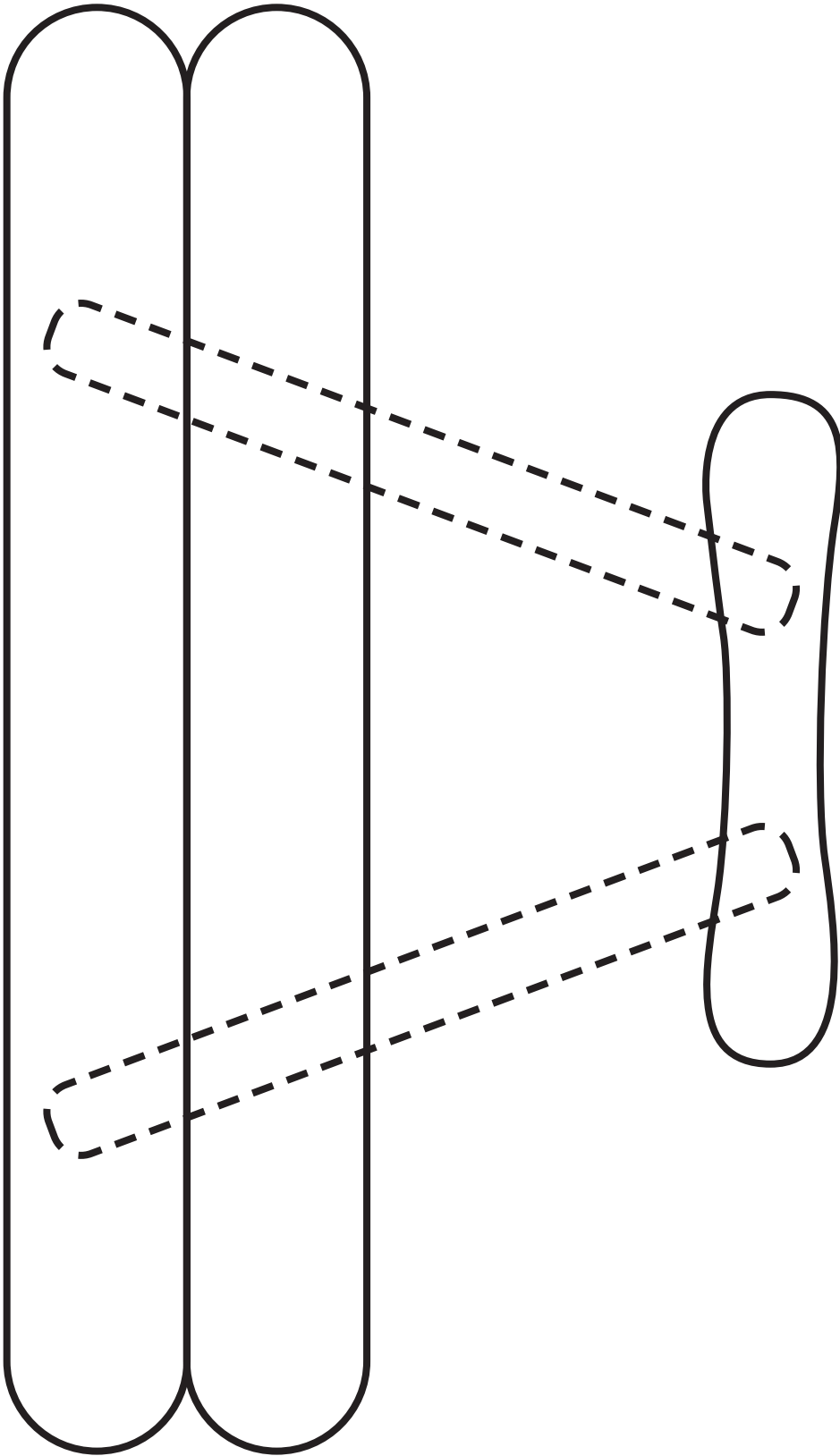

D

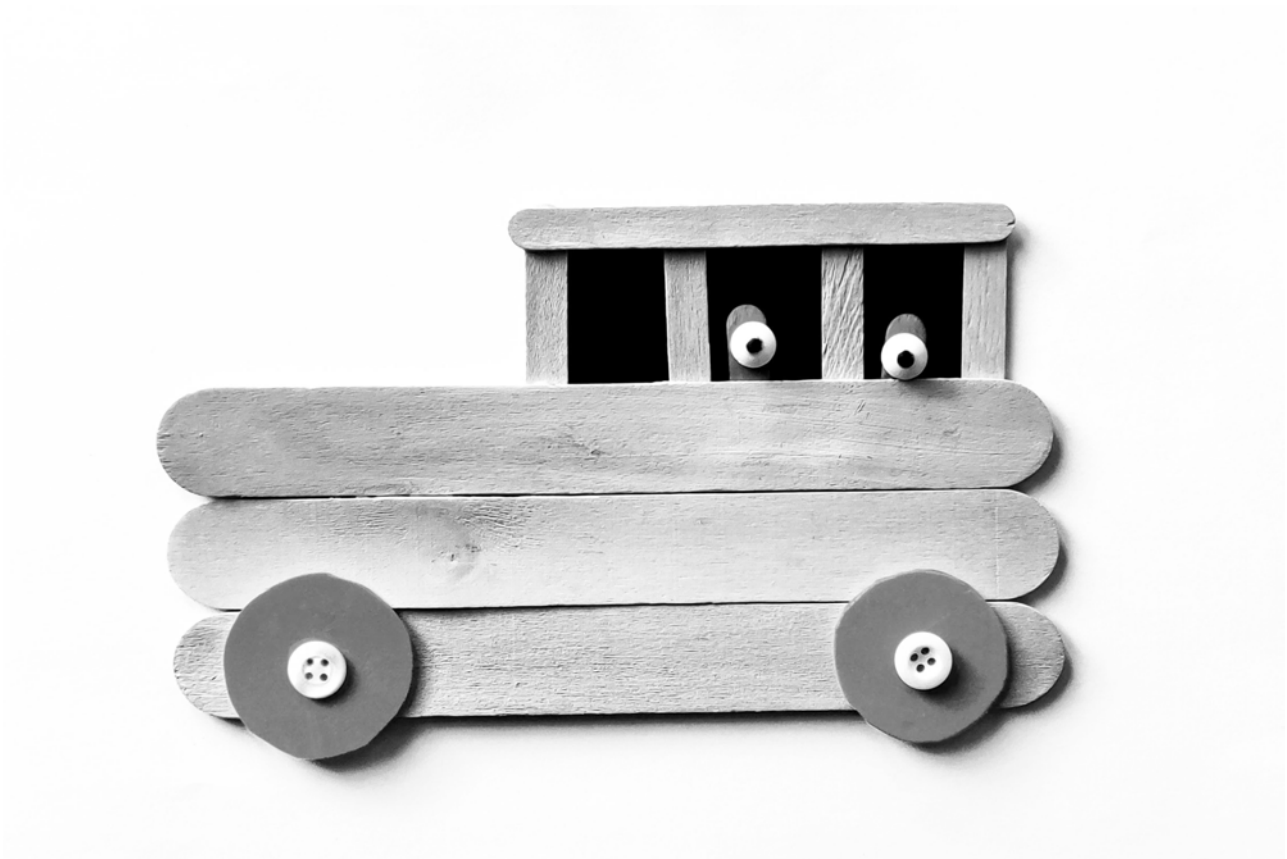

D1

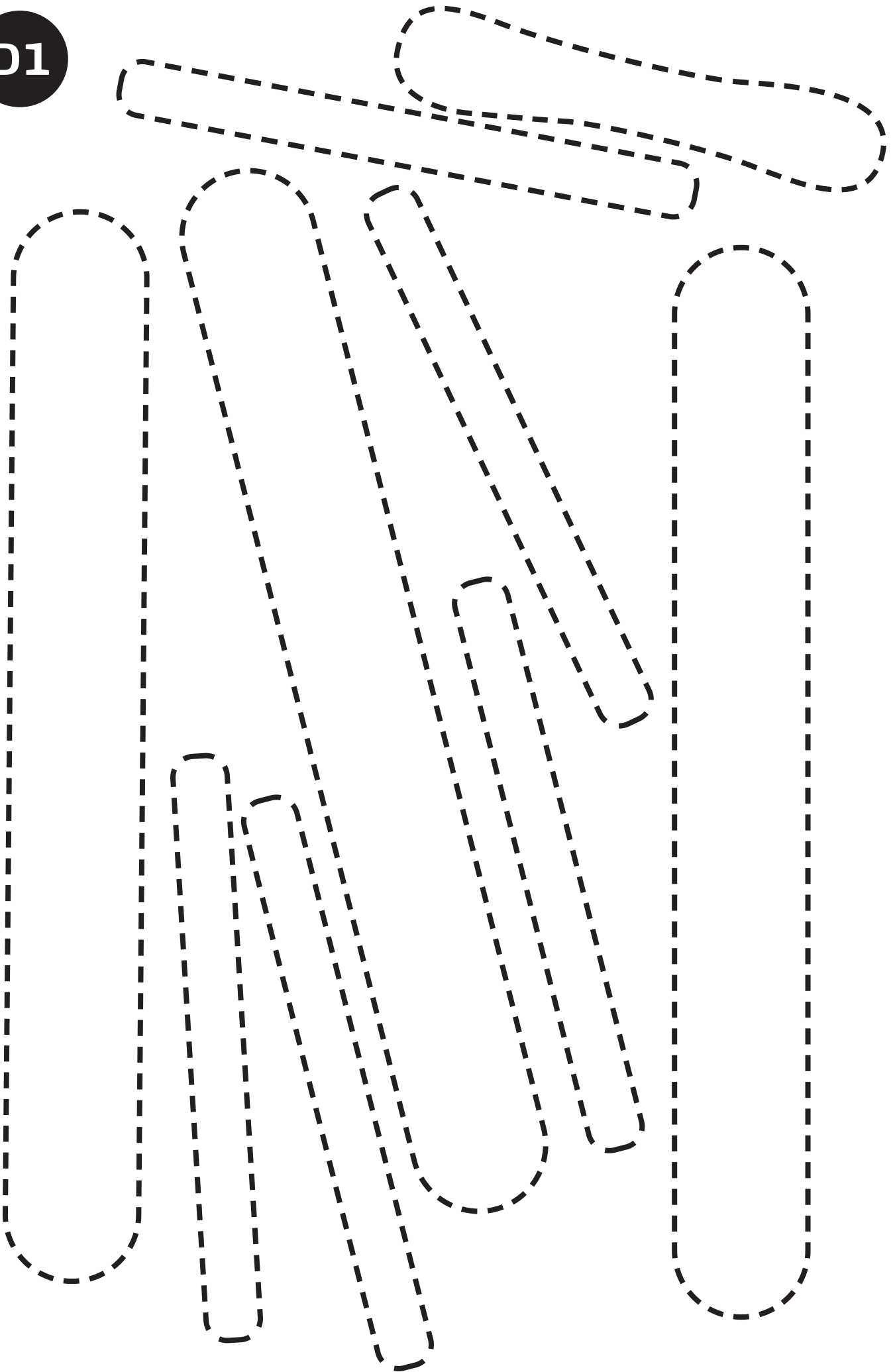

D2

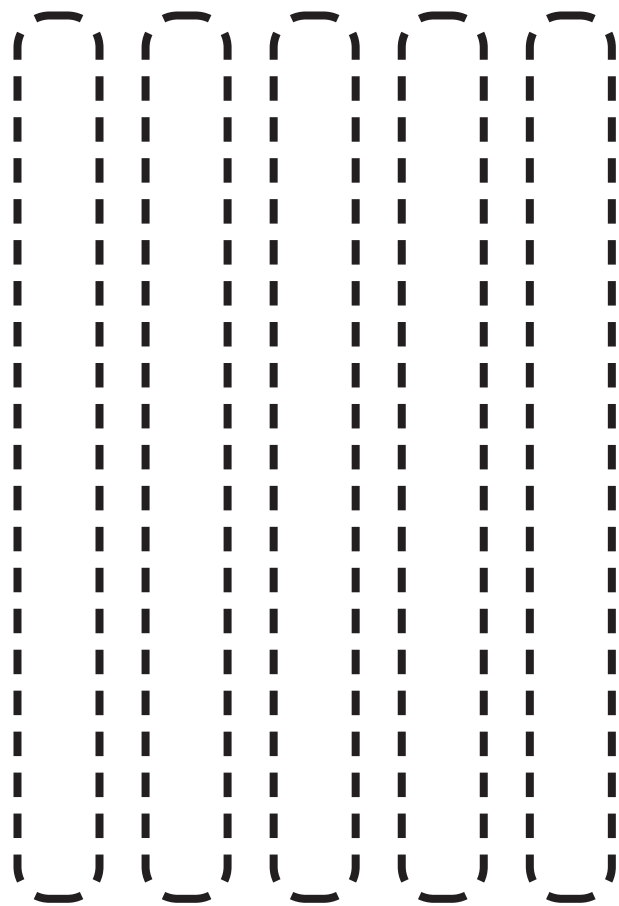
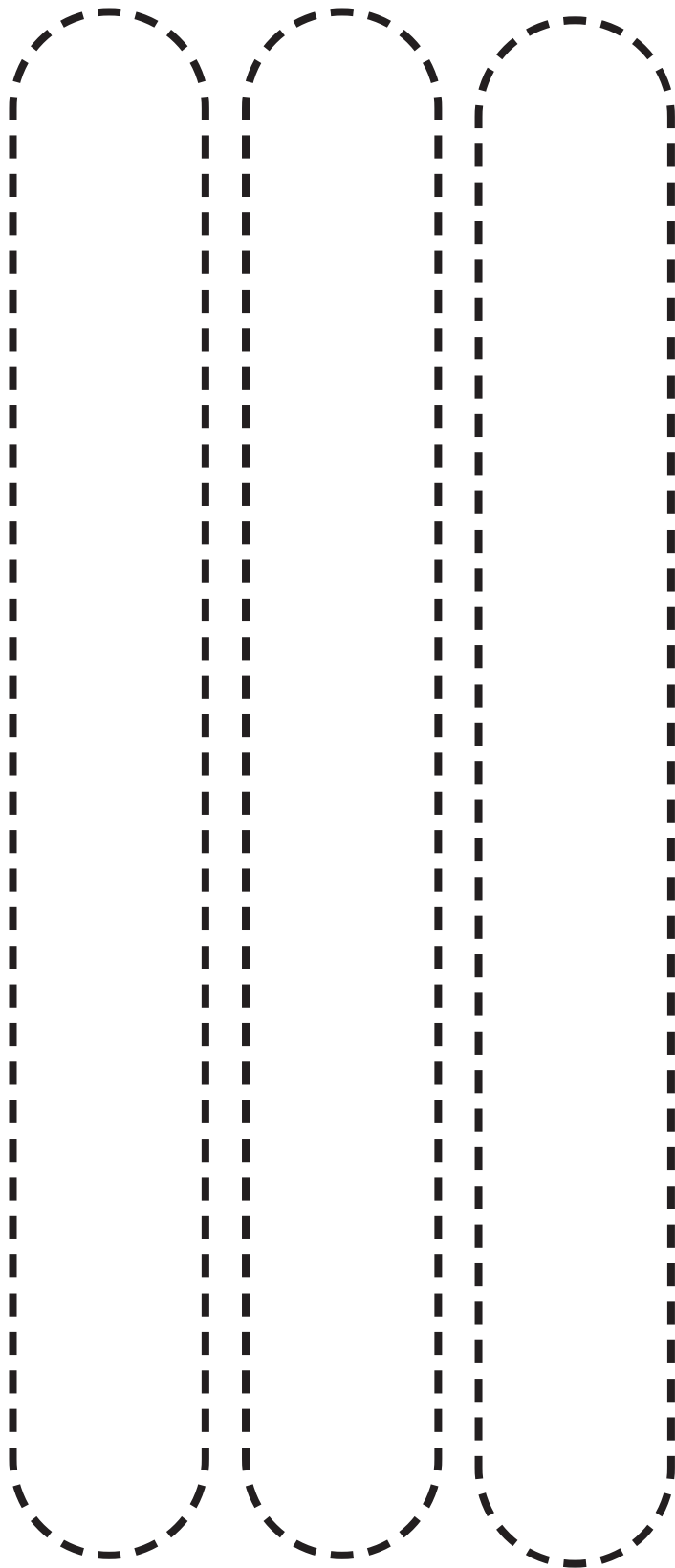

D3

3

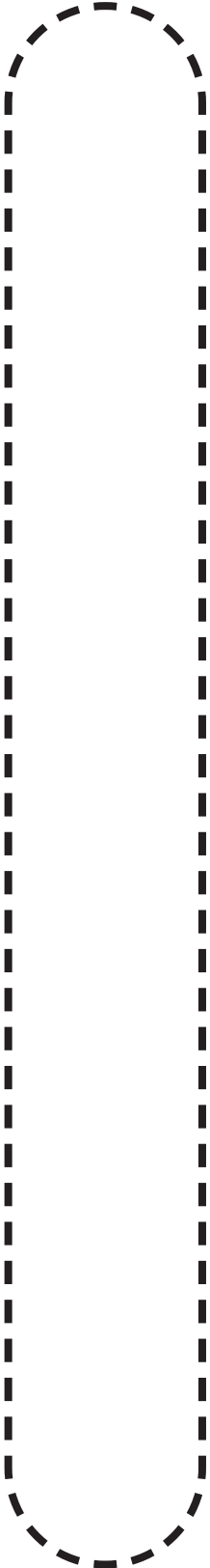

5



1

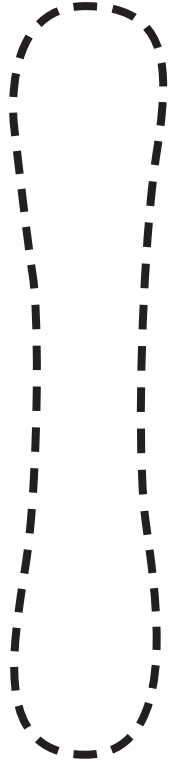

D4

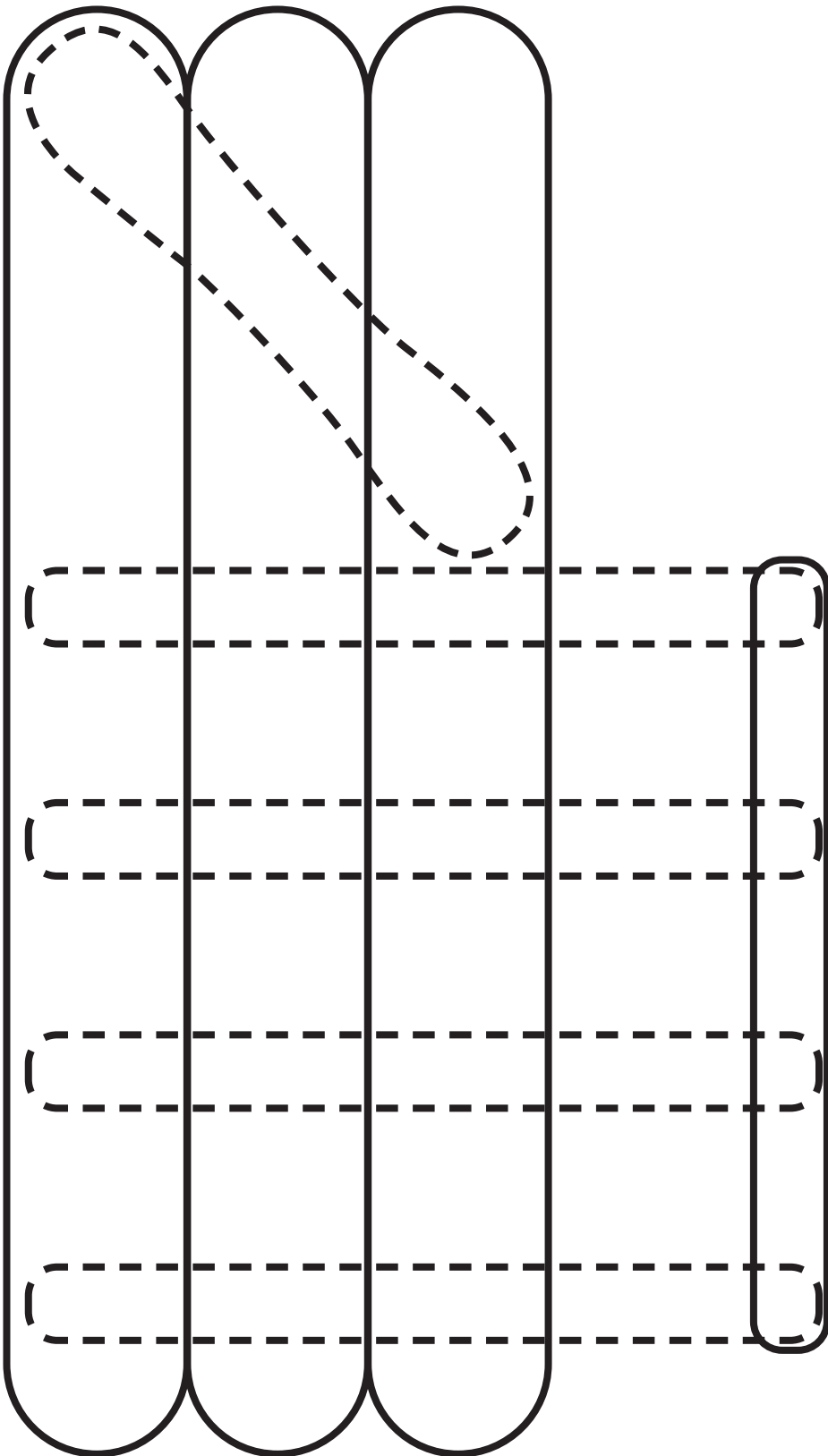

E



E1

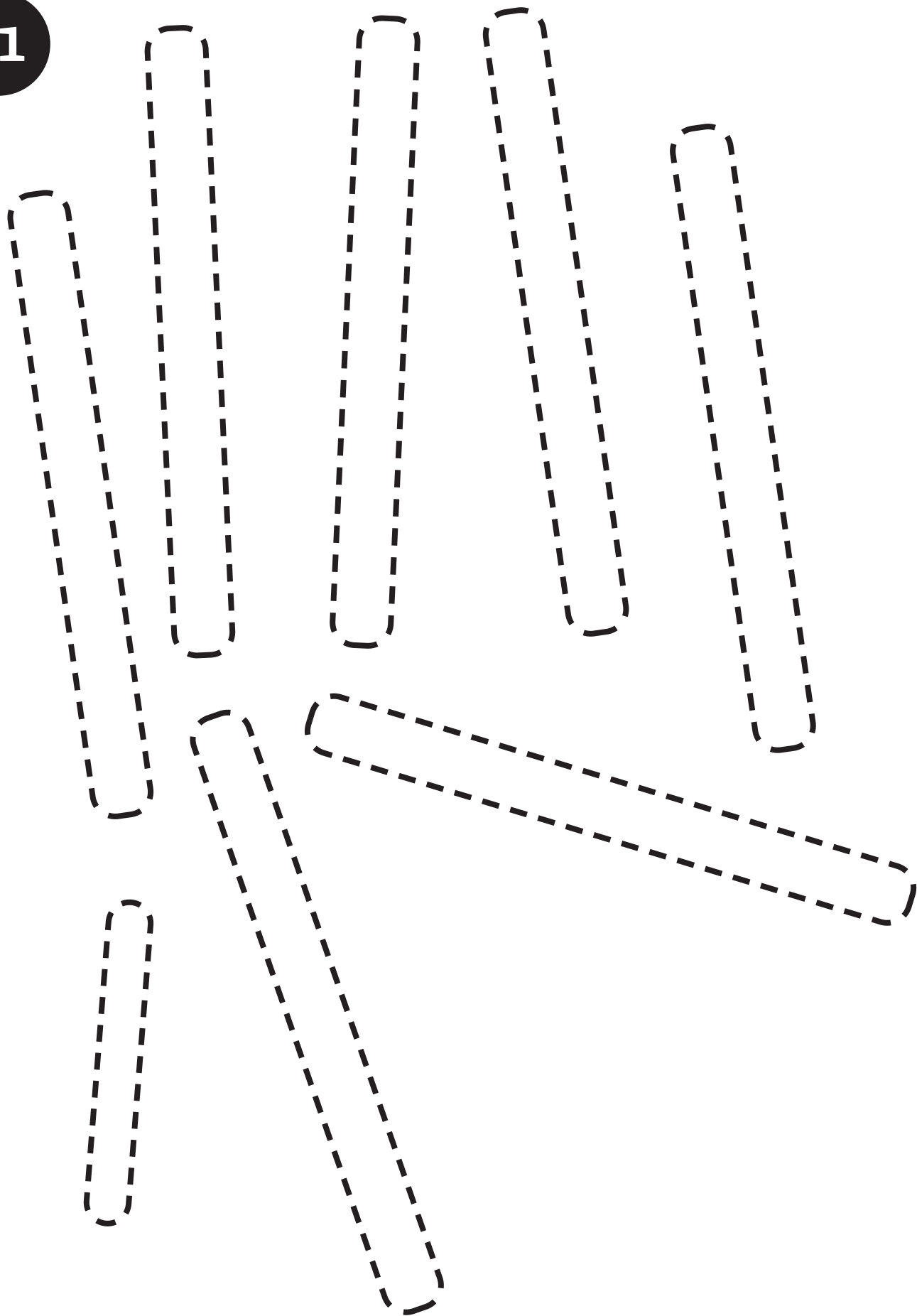

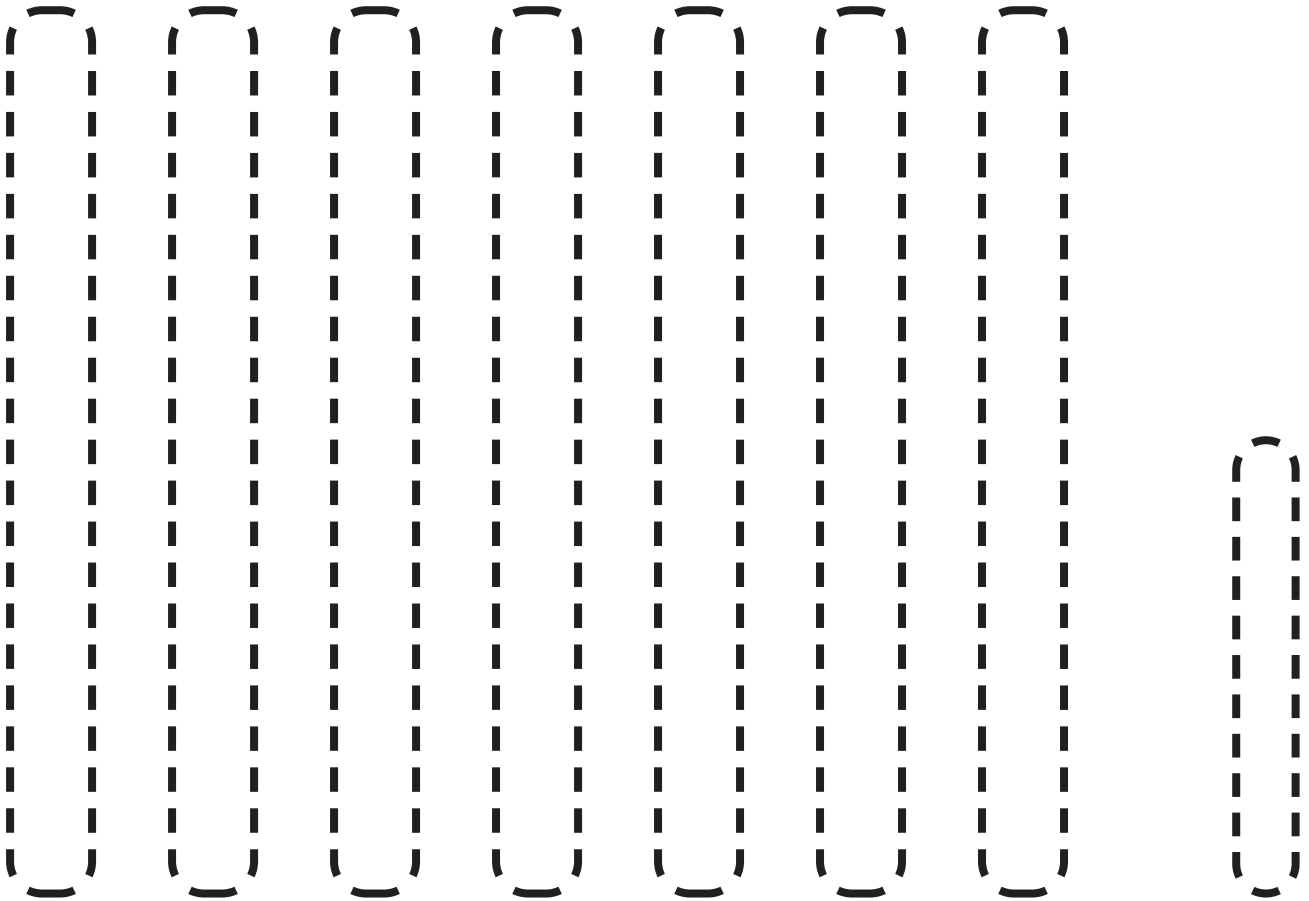

E3

7

1

7

1

E4

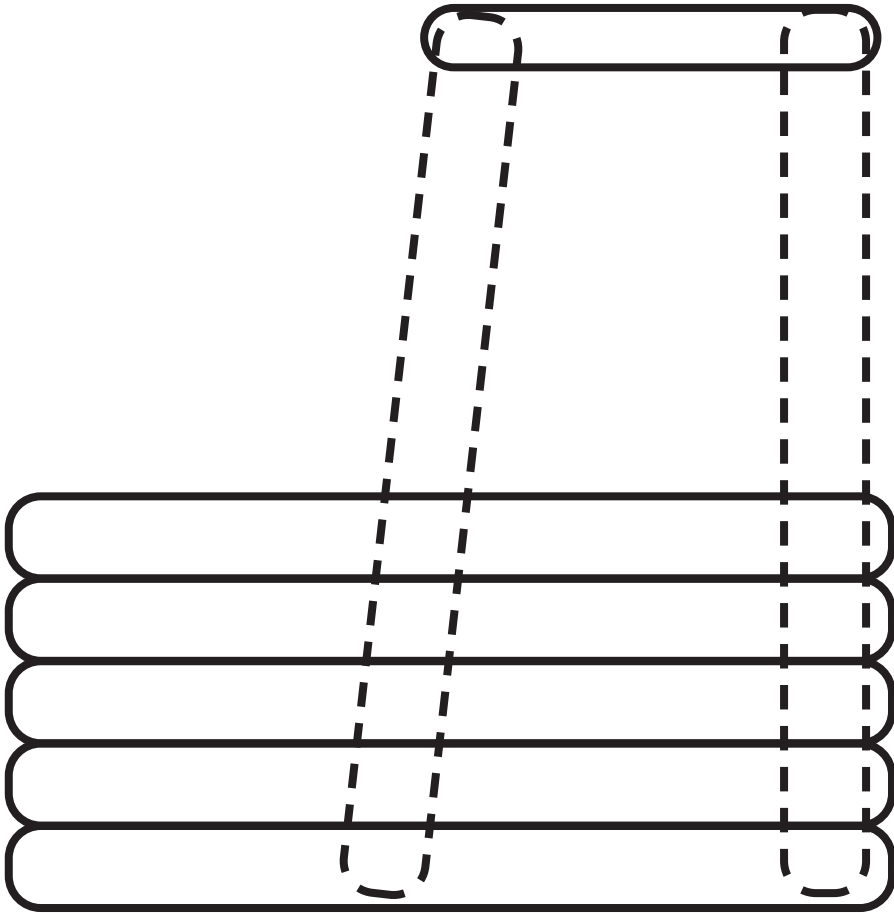

F



F1

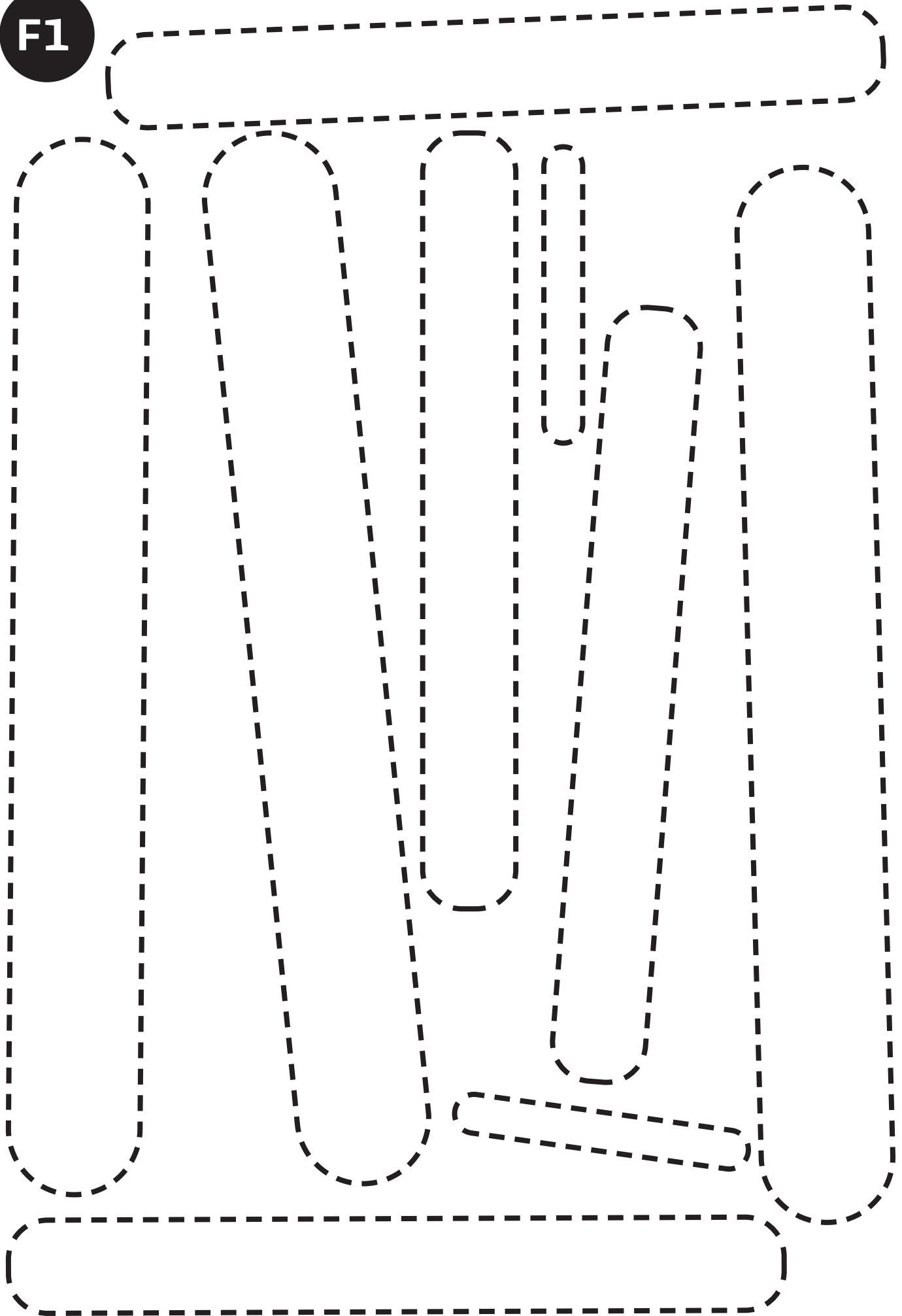

F2

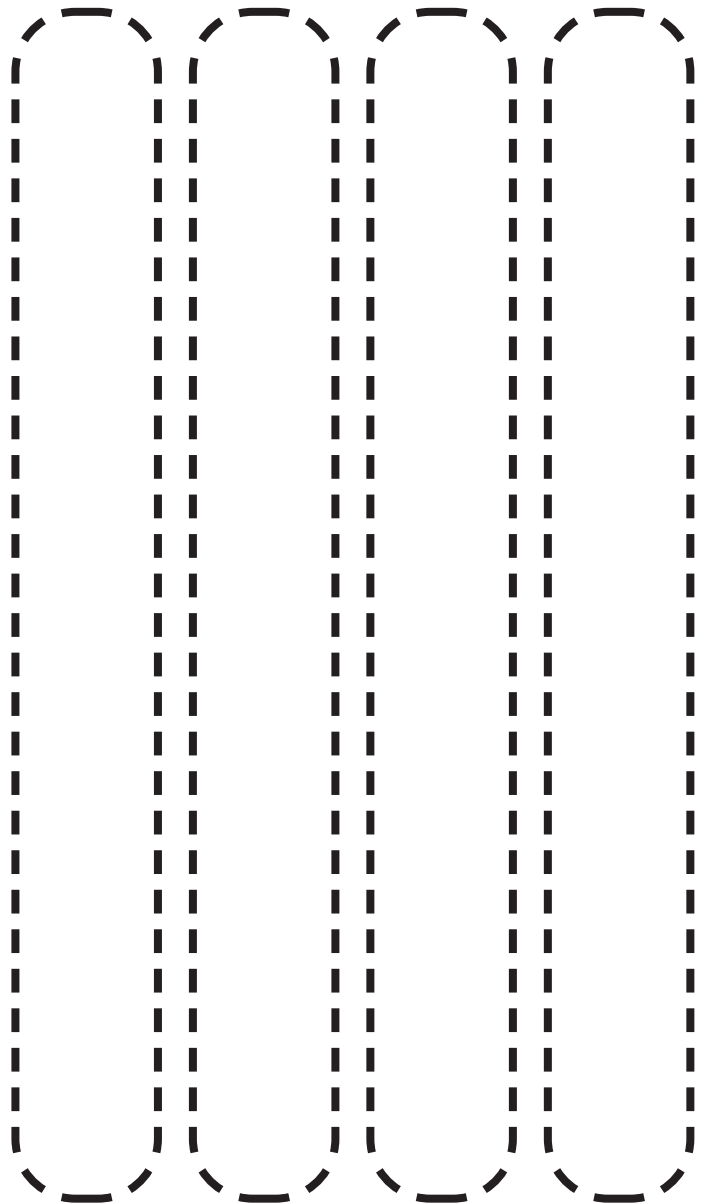
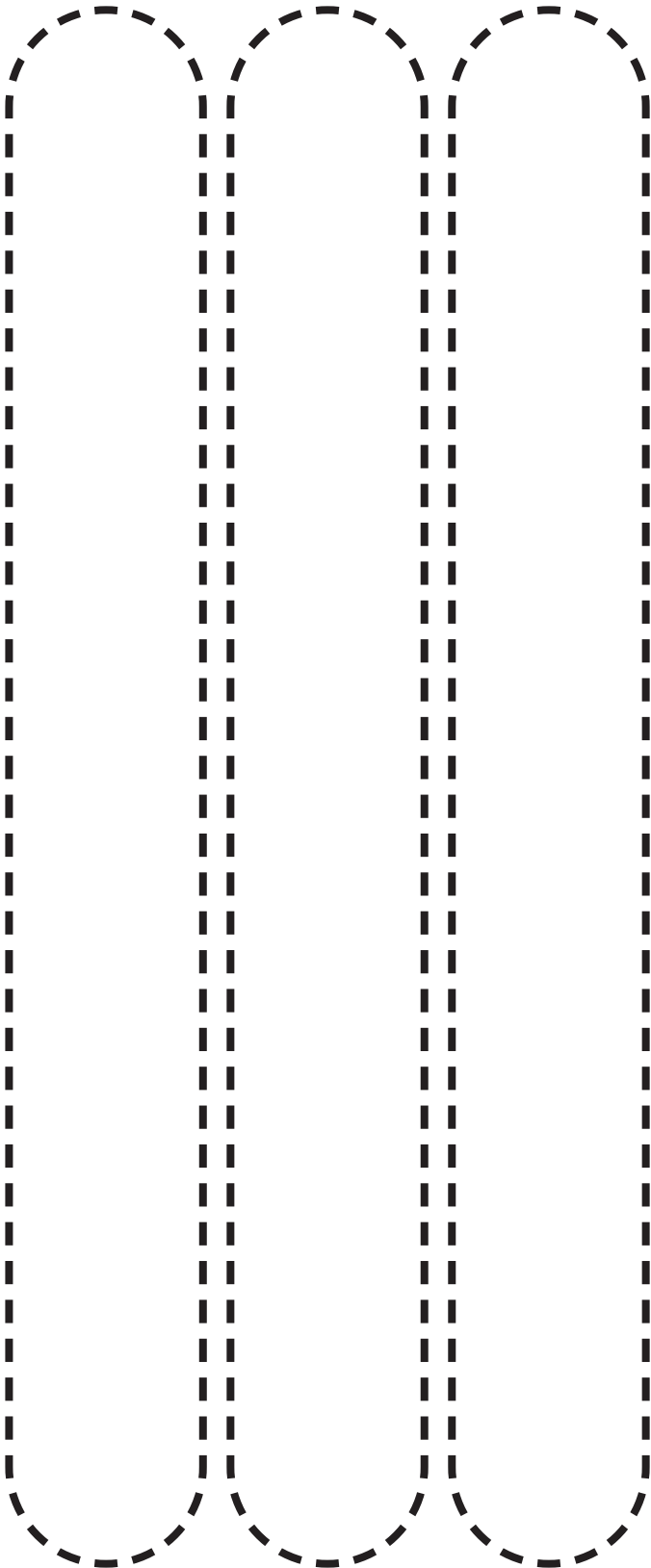

F3

3

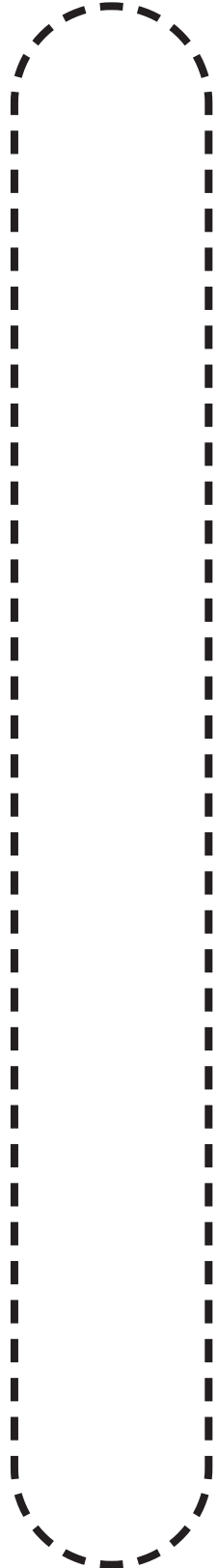

4



2



F4

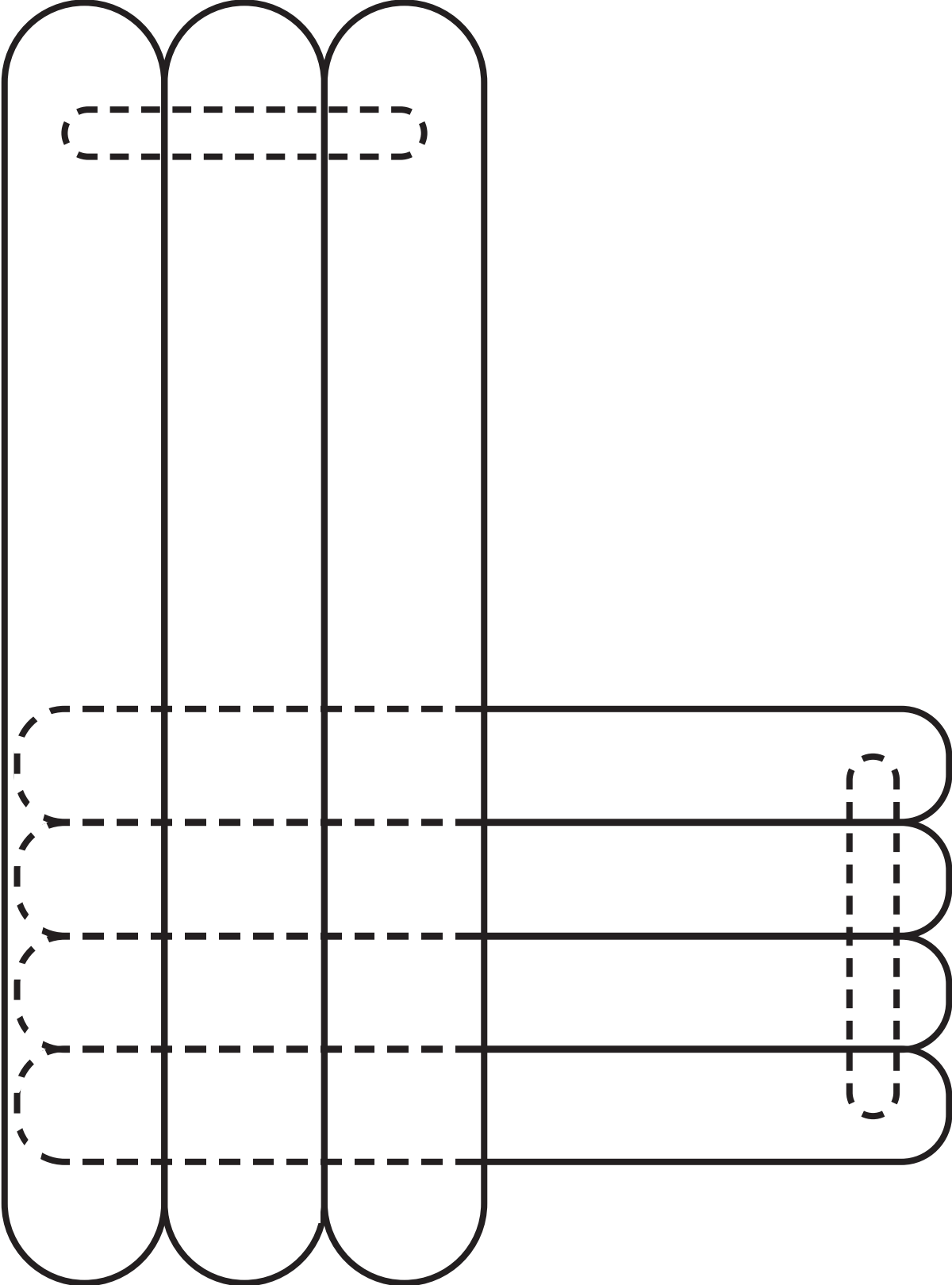

G



G1

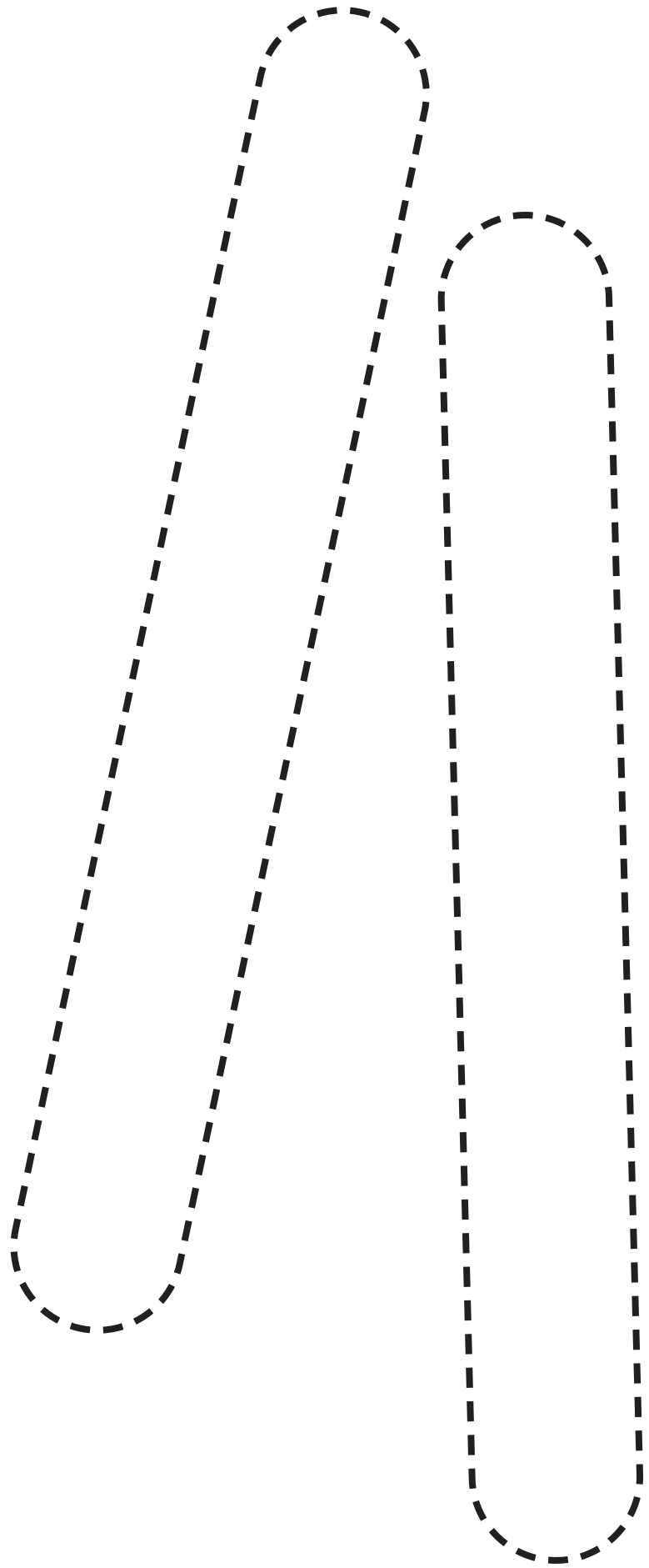
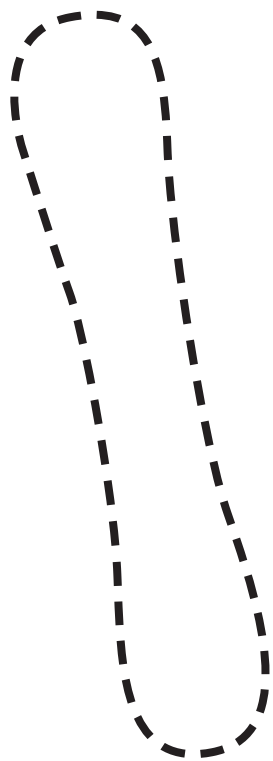
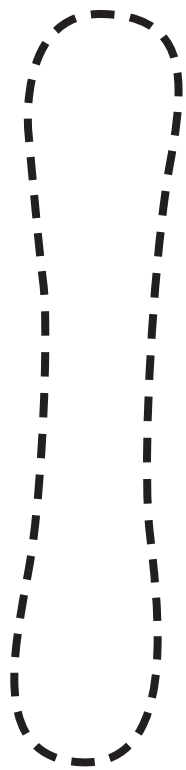
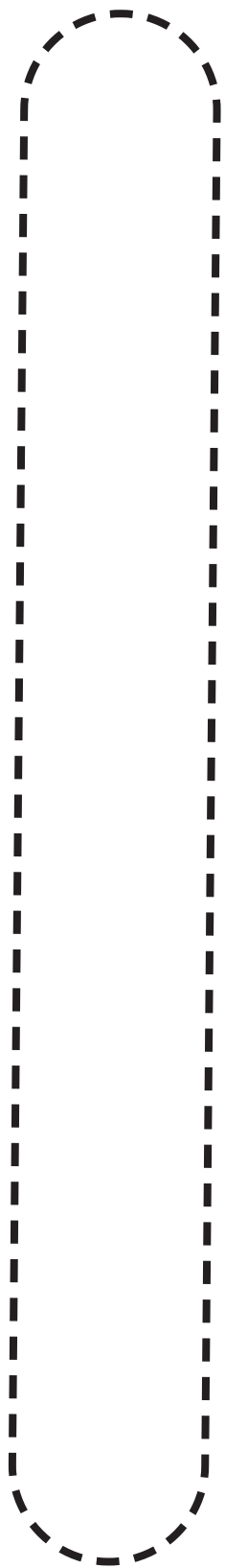

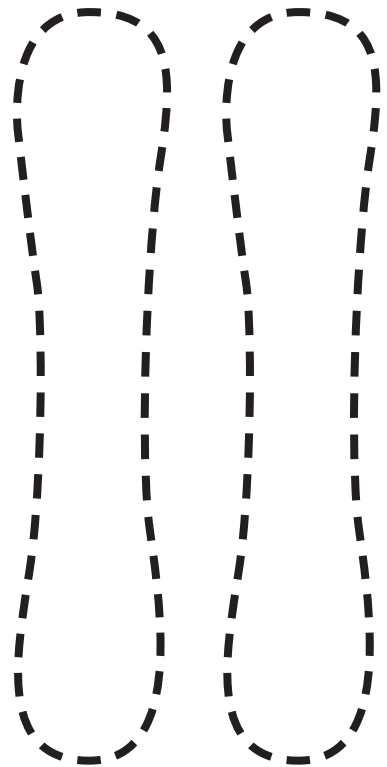
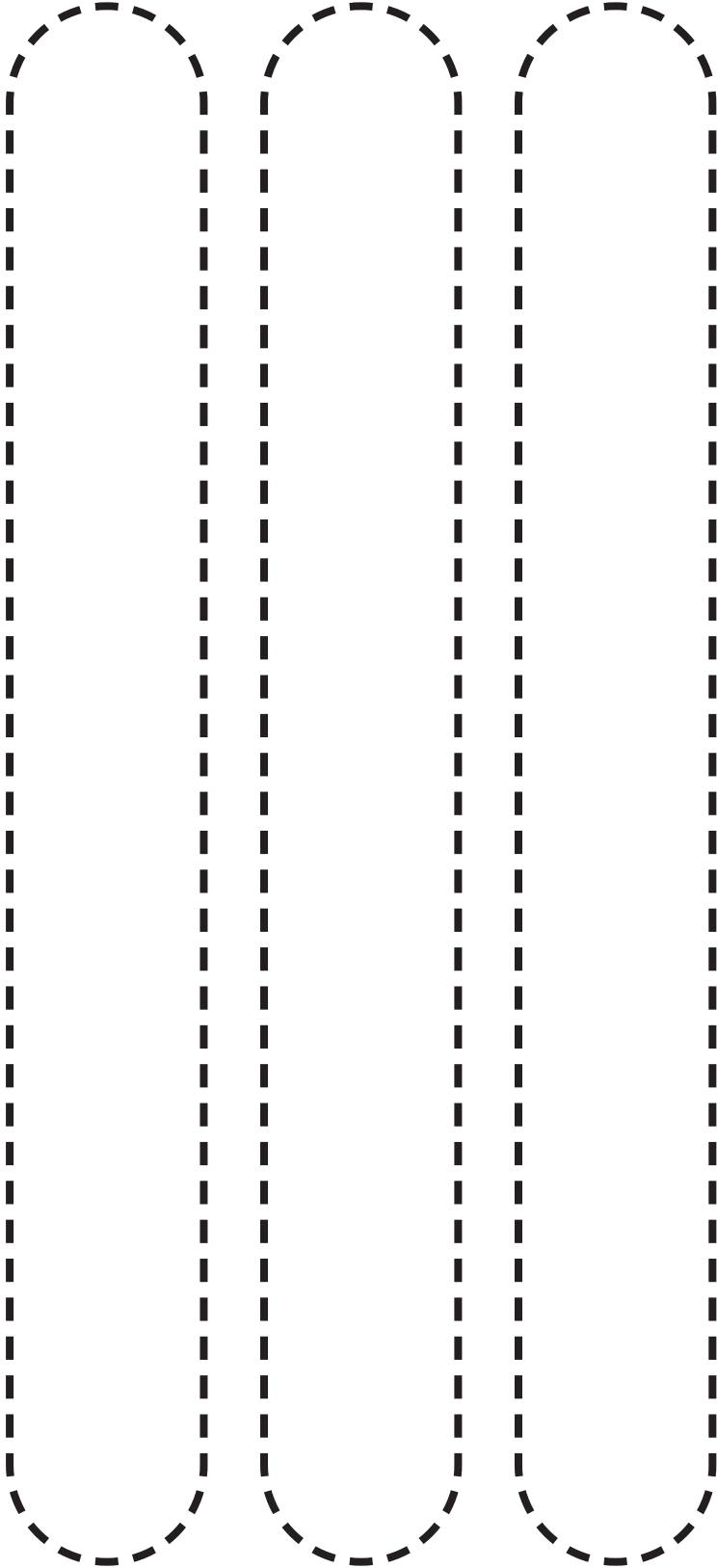

3

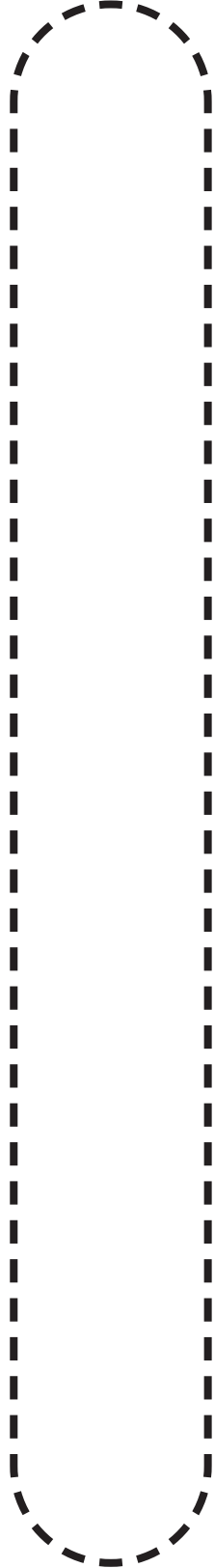

2

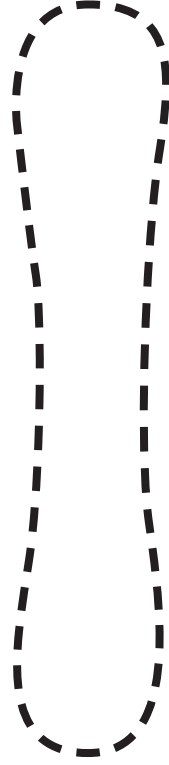

G4

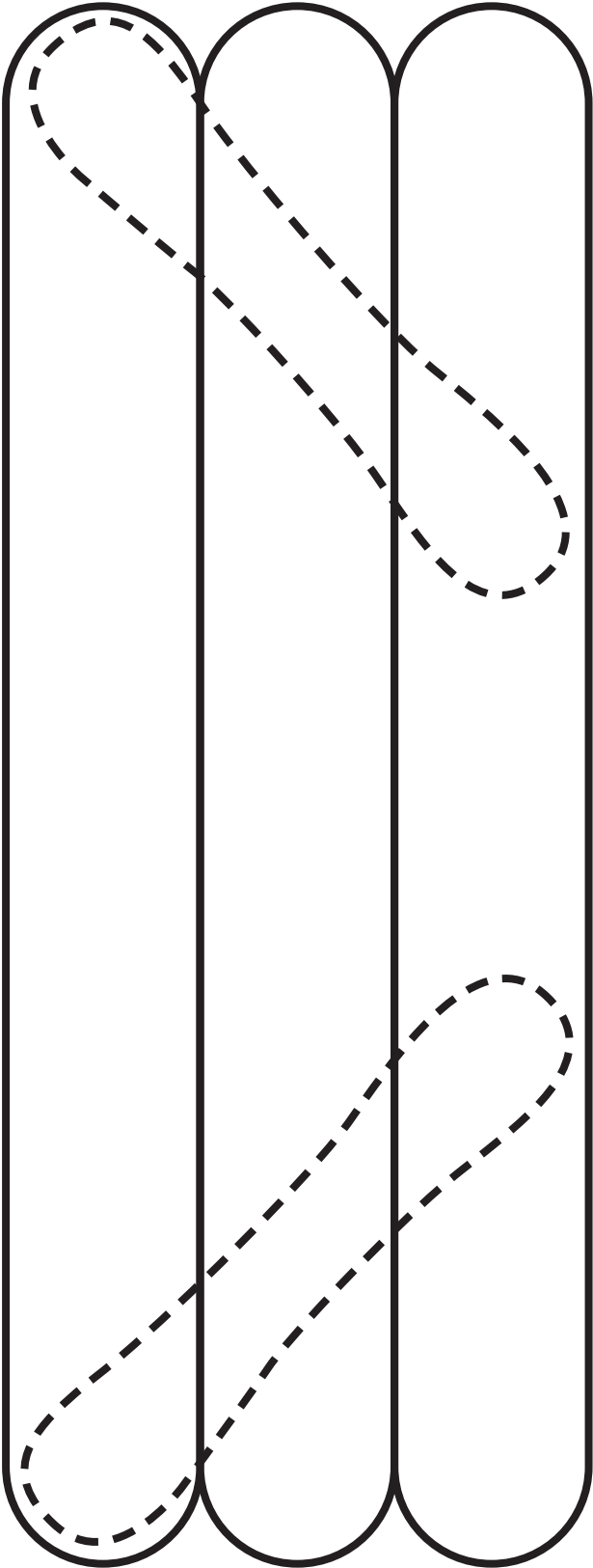

H

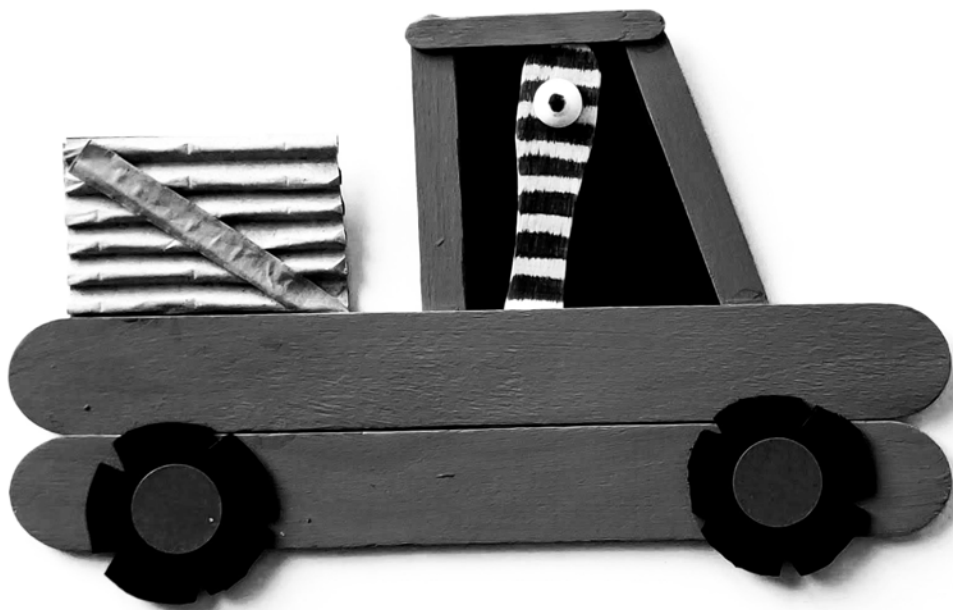

H1

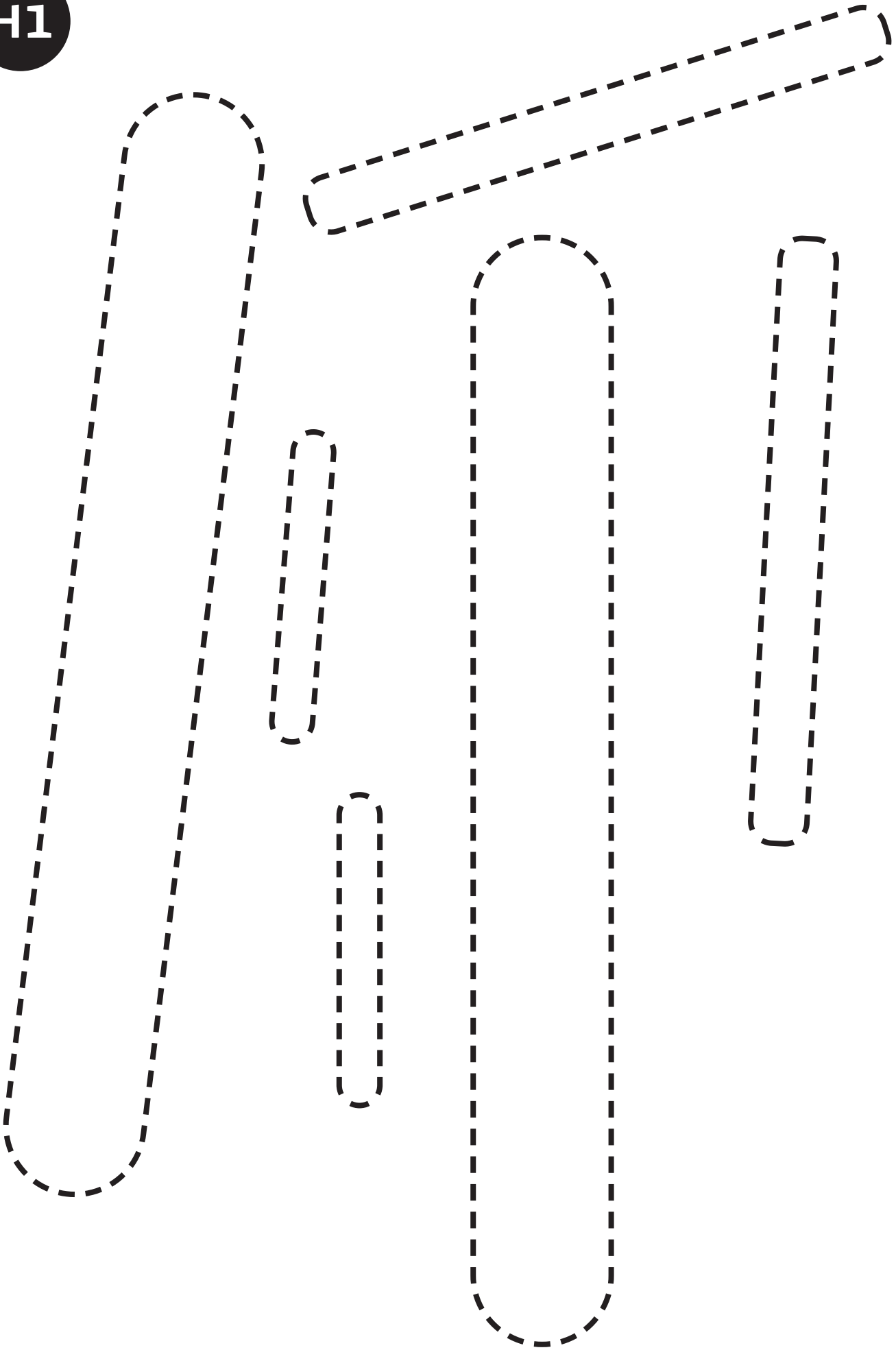

H2

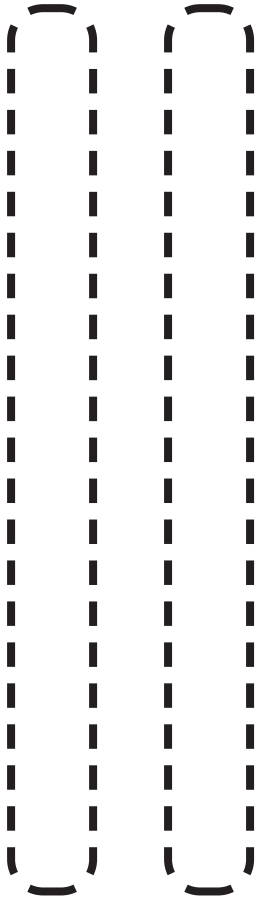
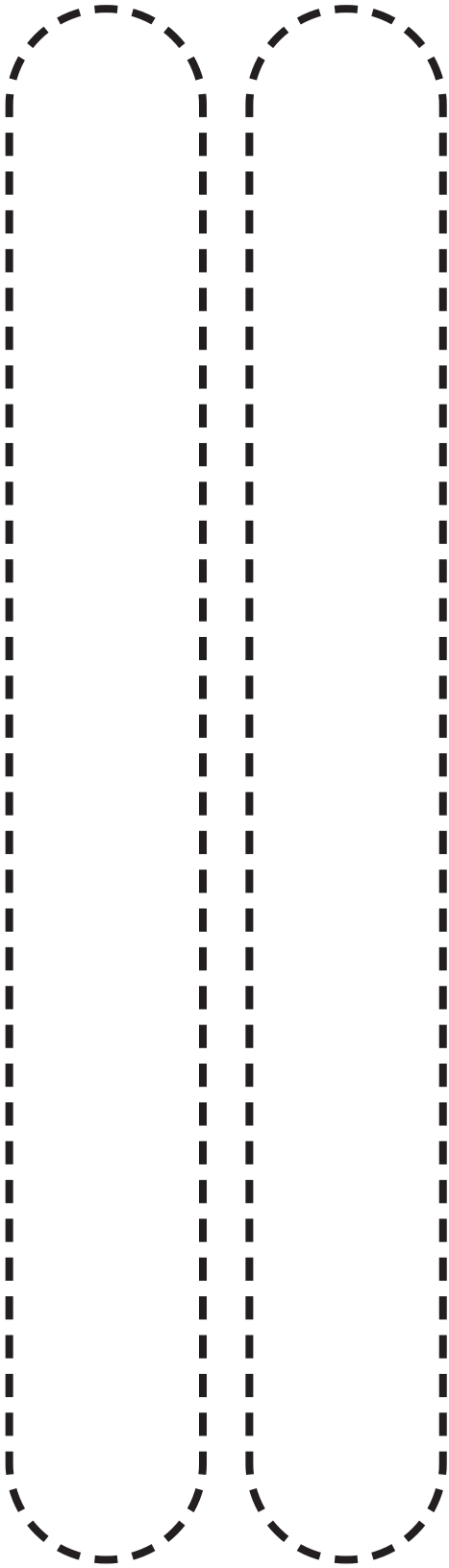

H3

2

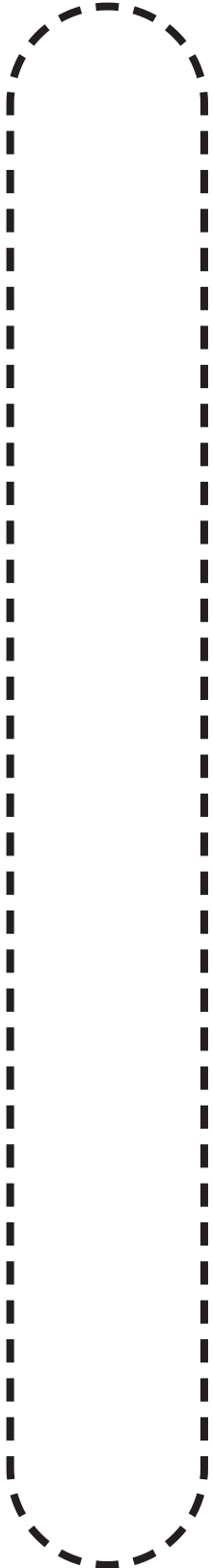

2



2



H4

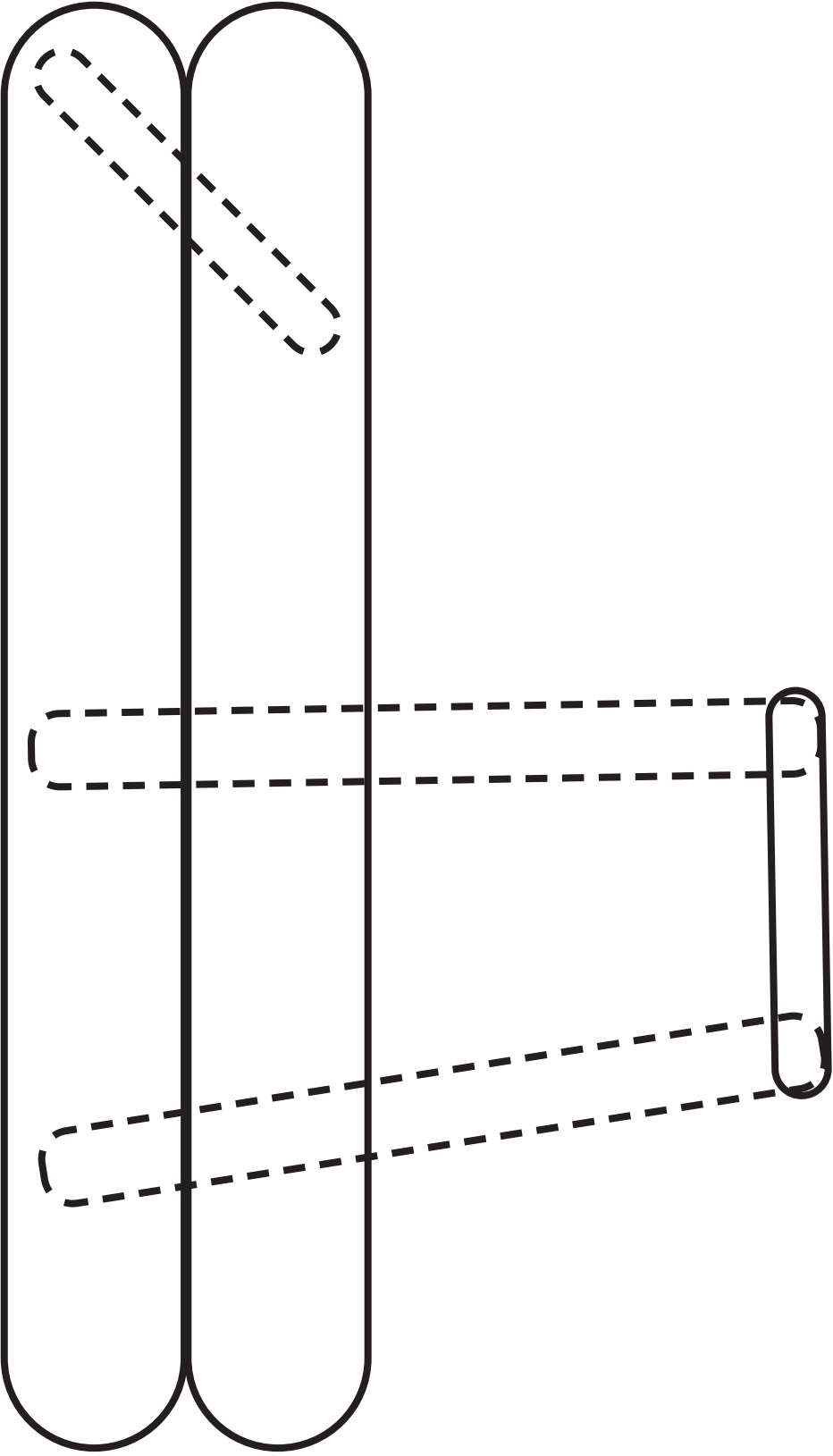

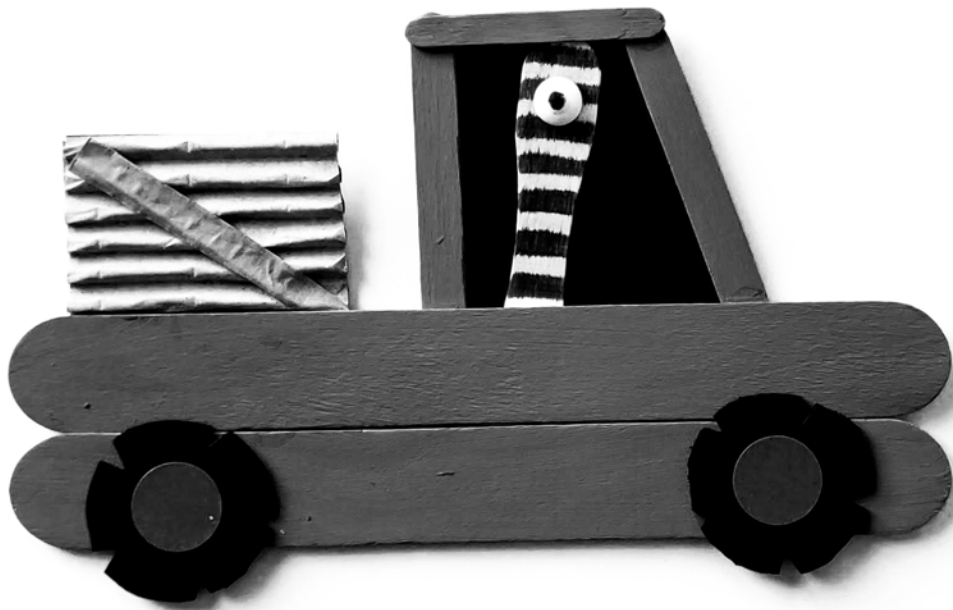

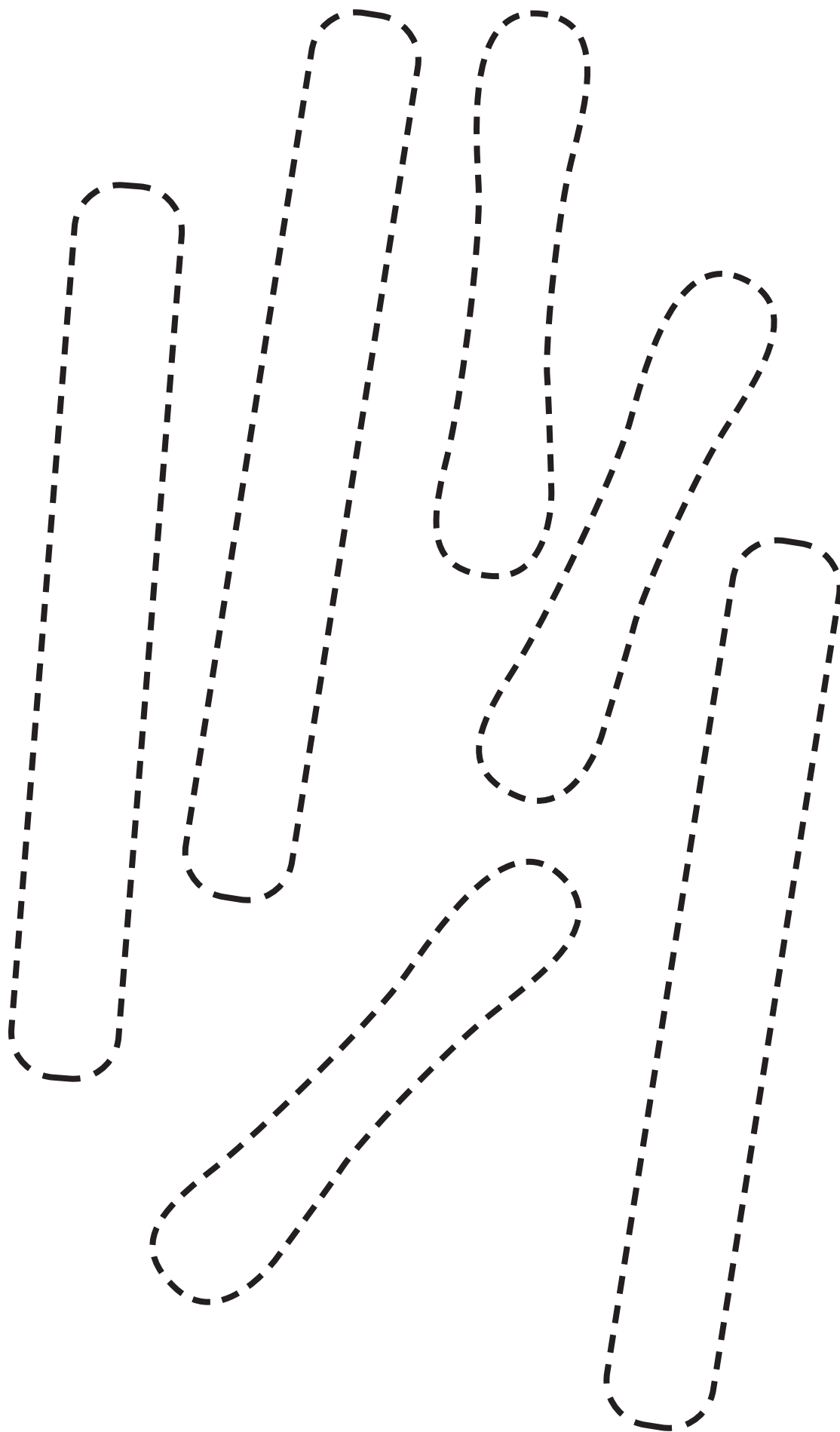

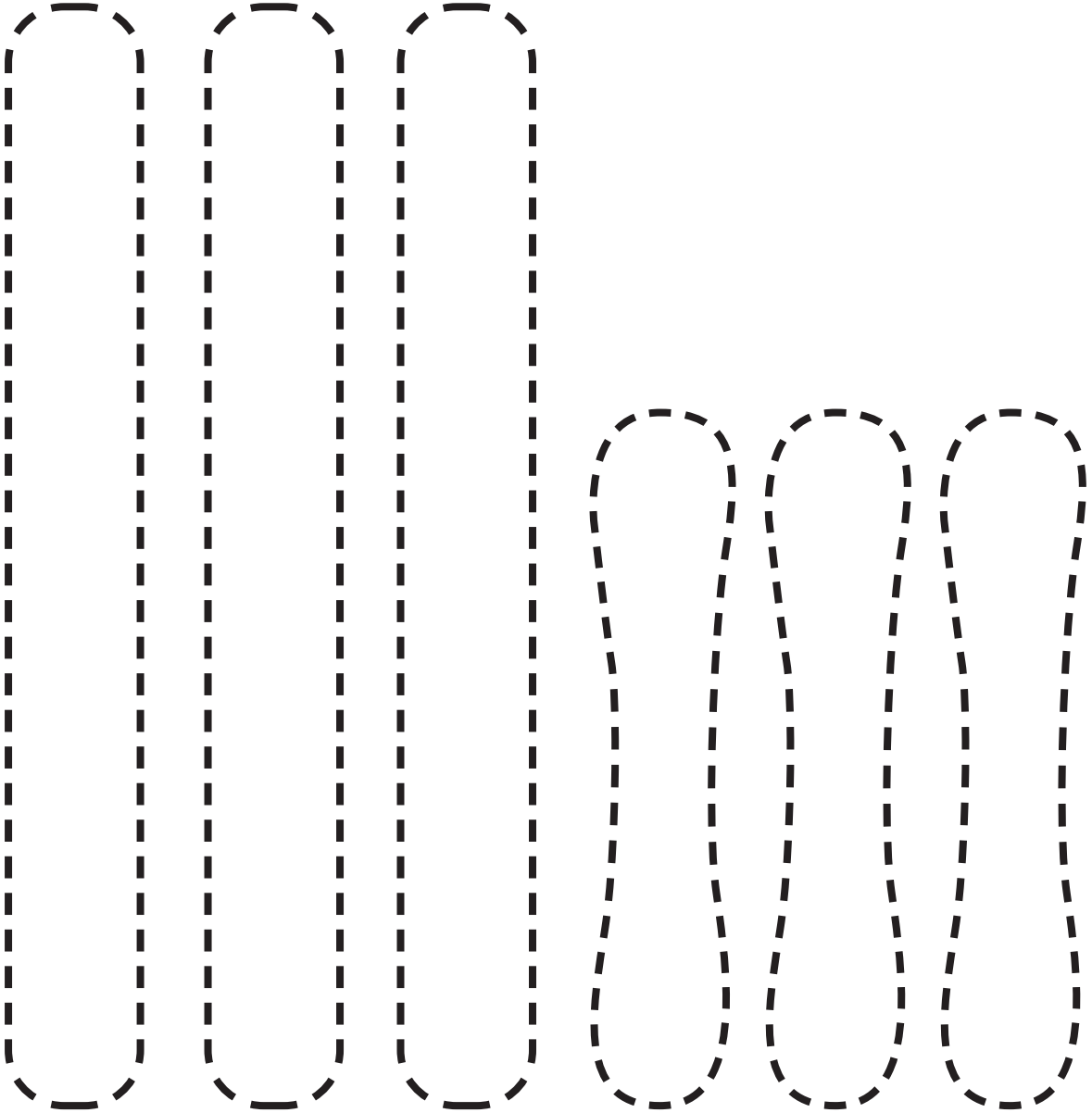

3

3



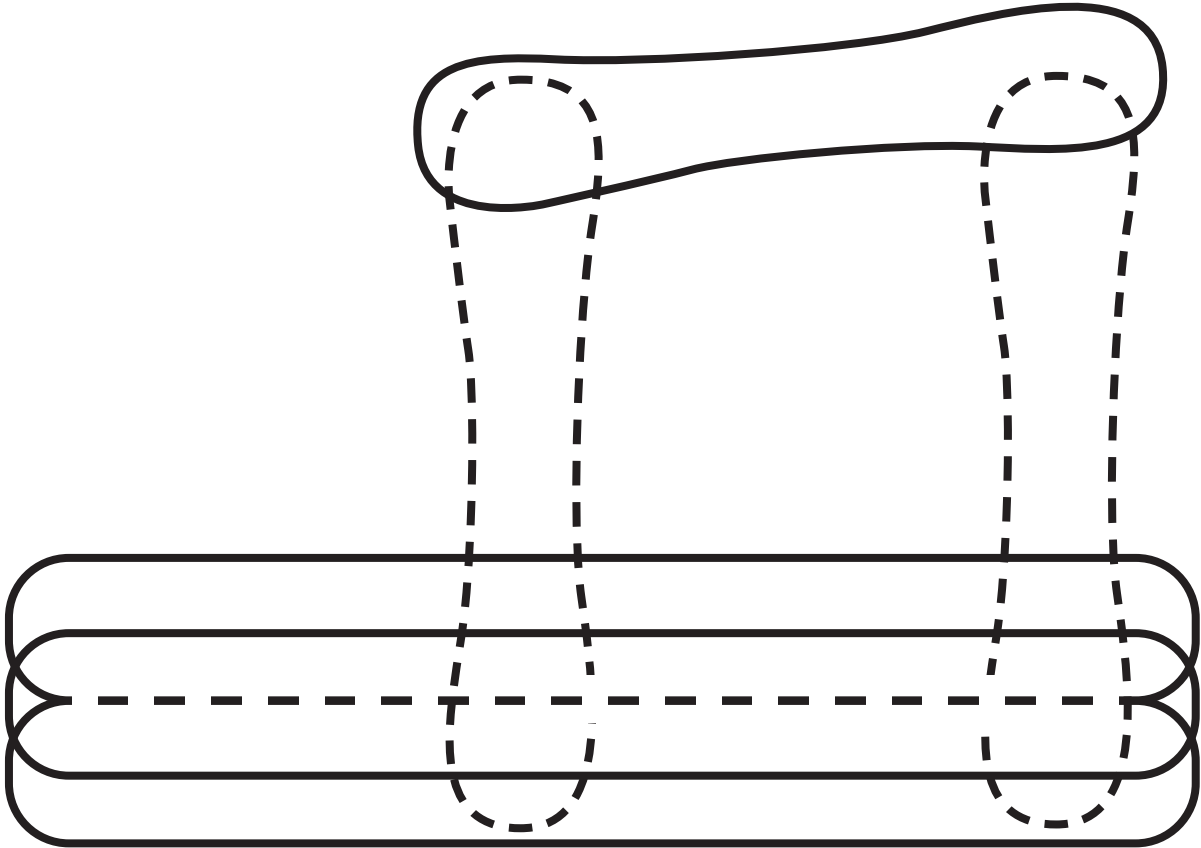

J

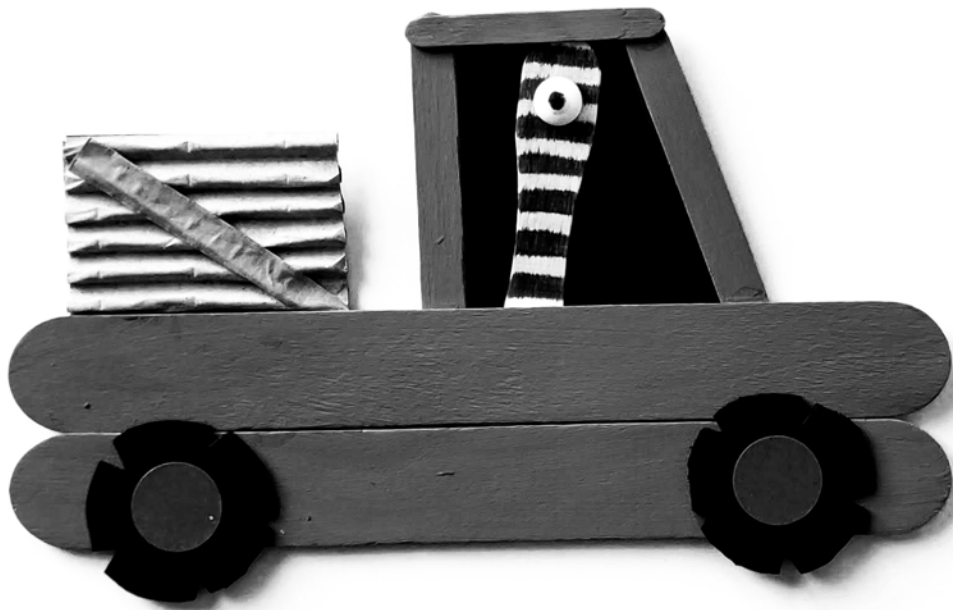

J1

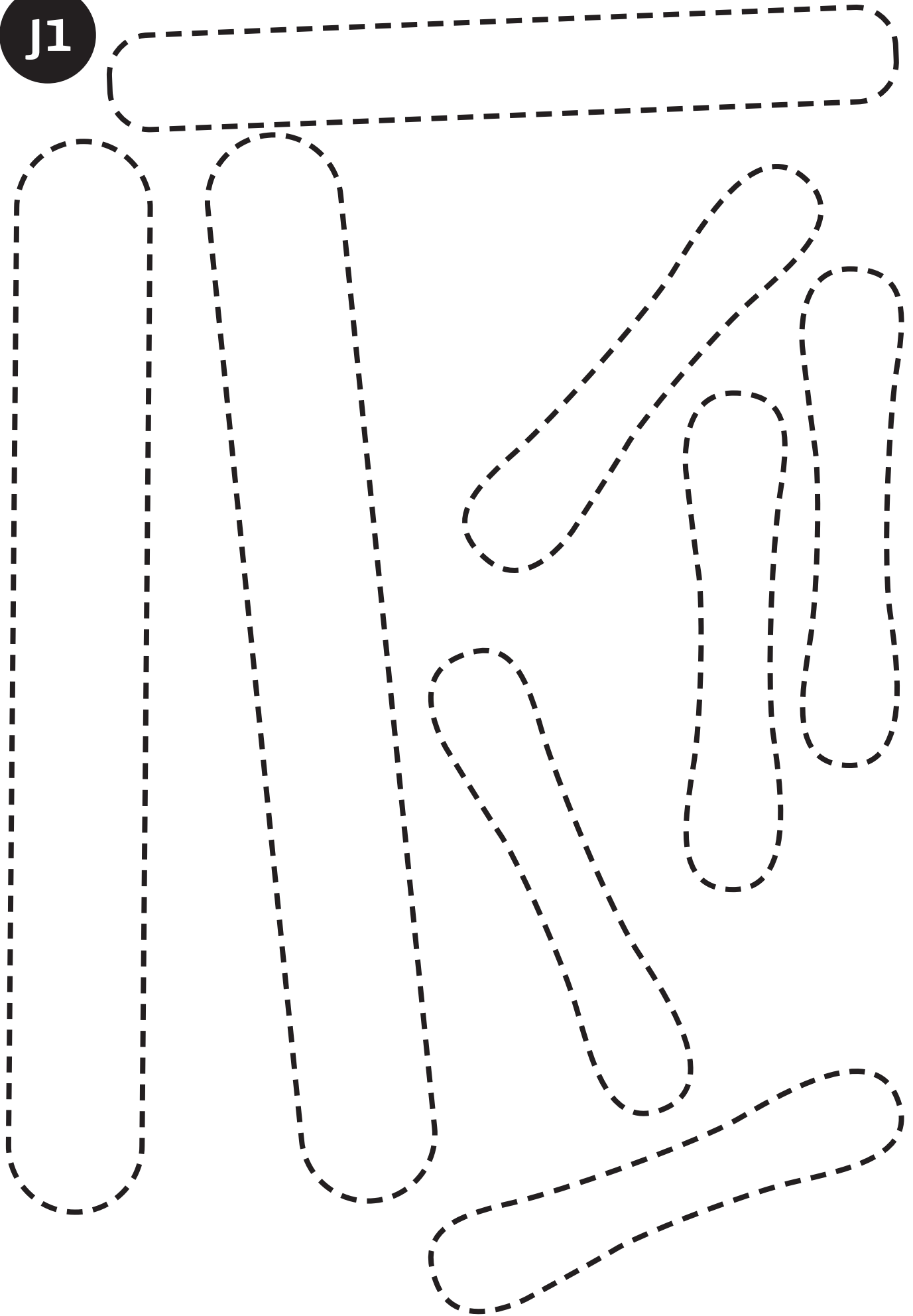

J2

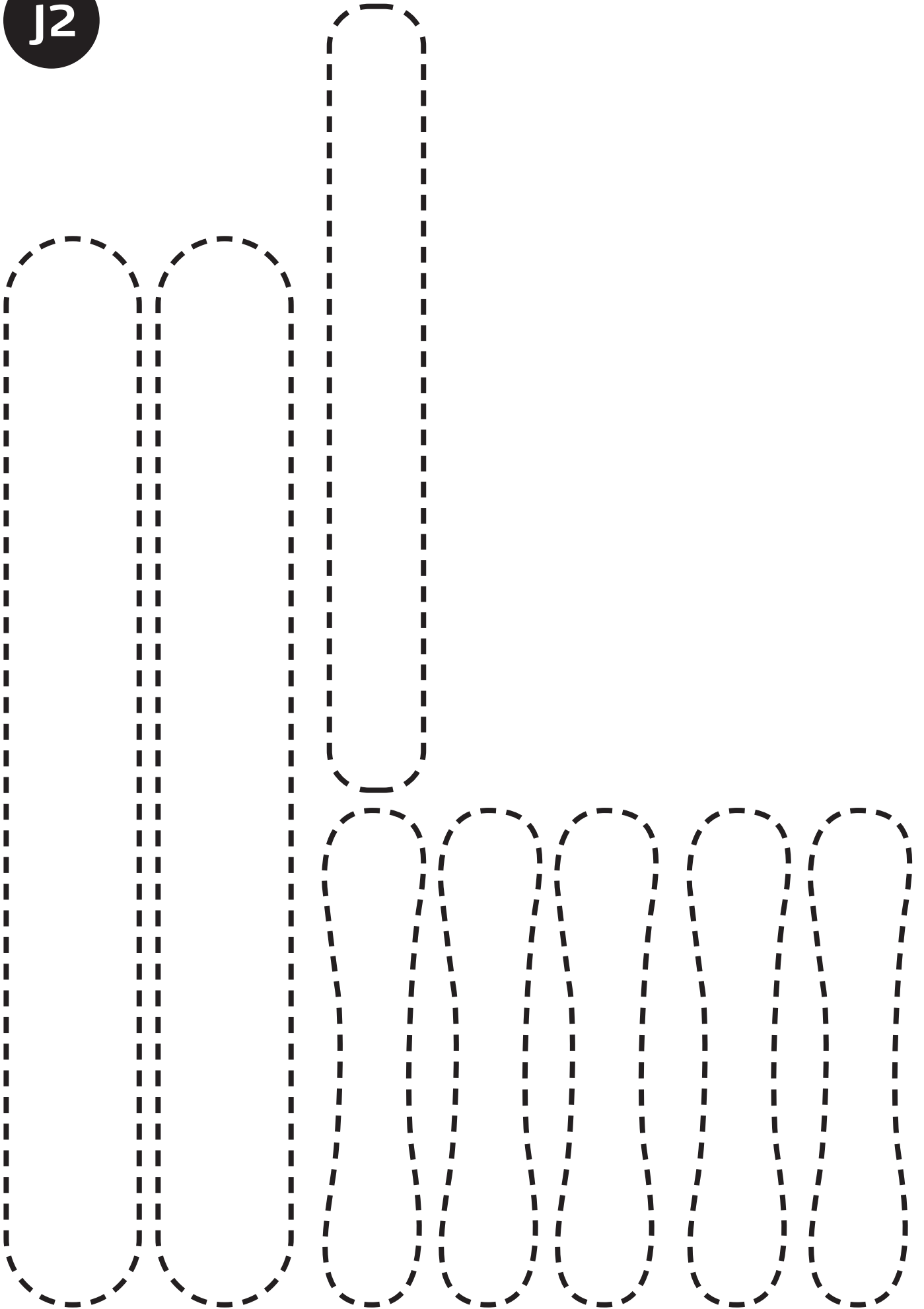

J3

2

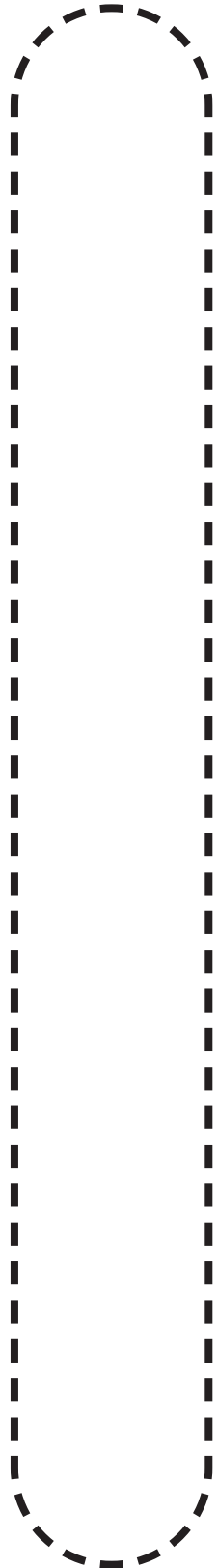

1



5

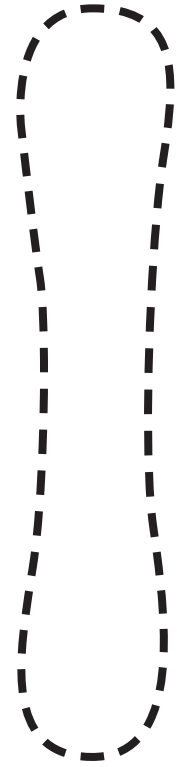

J4

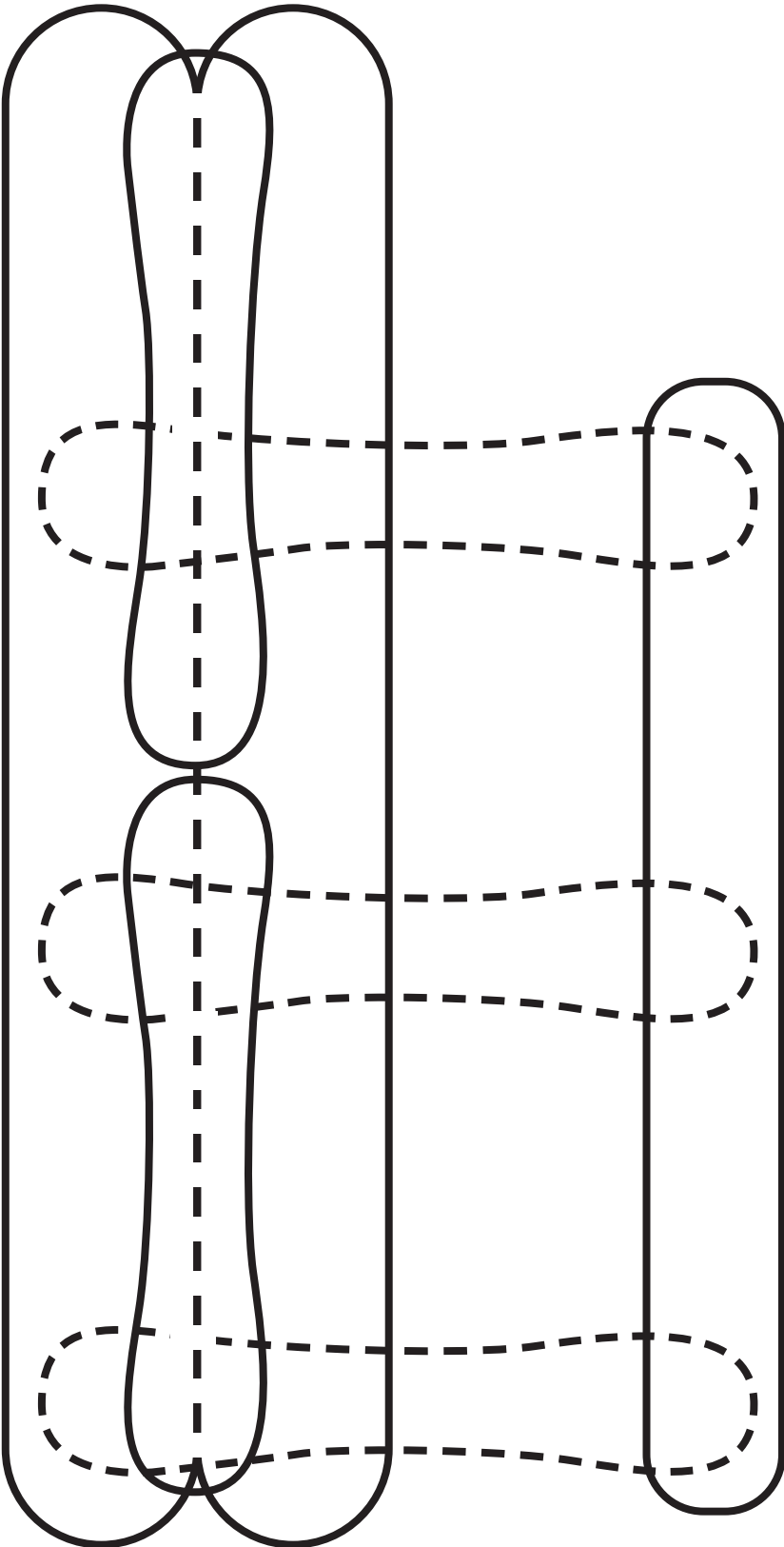

K

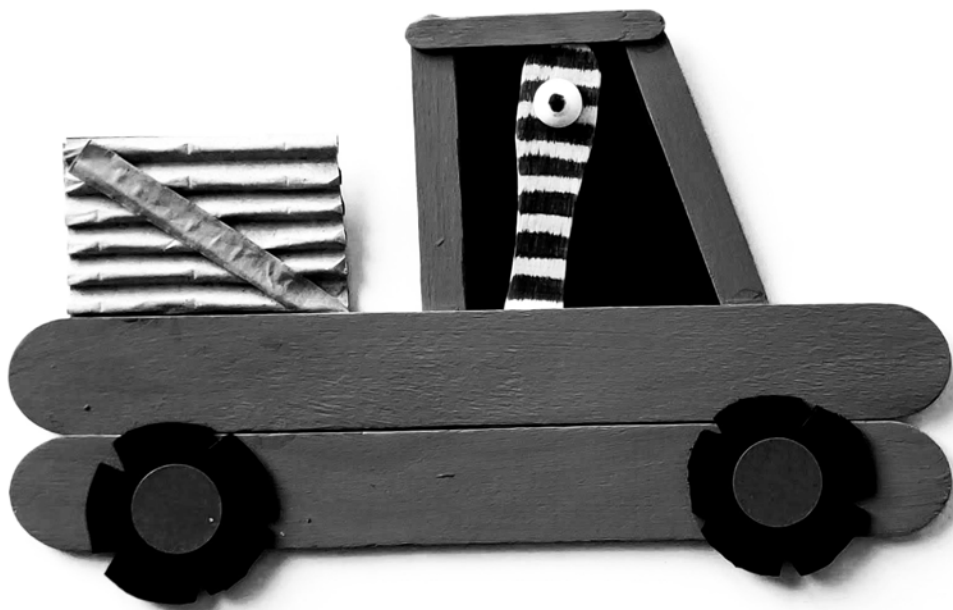

K1

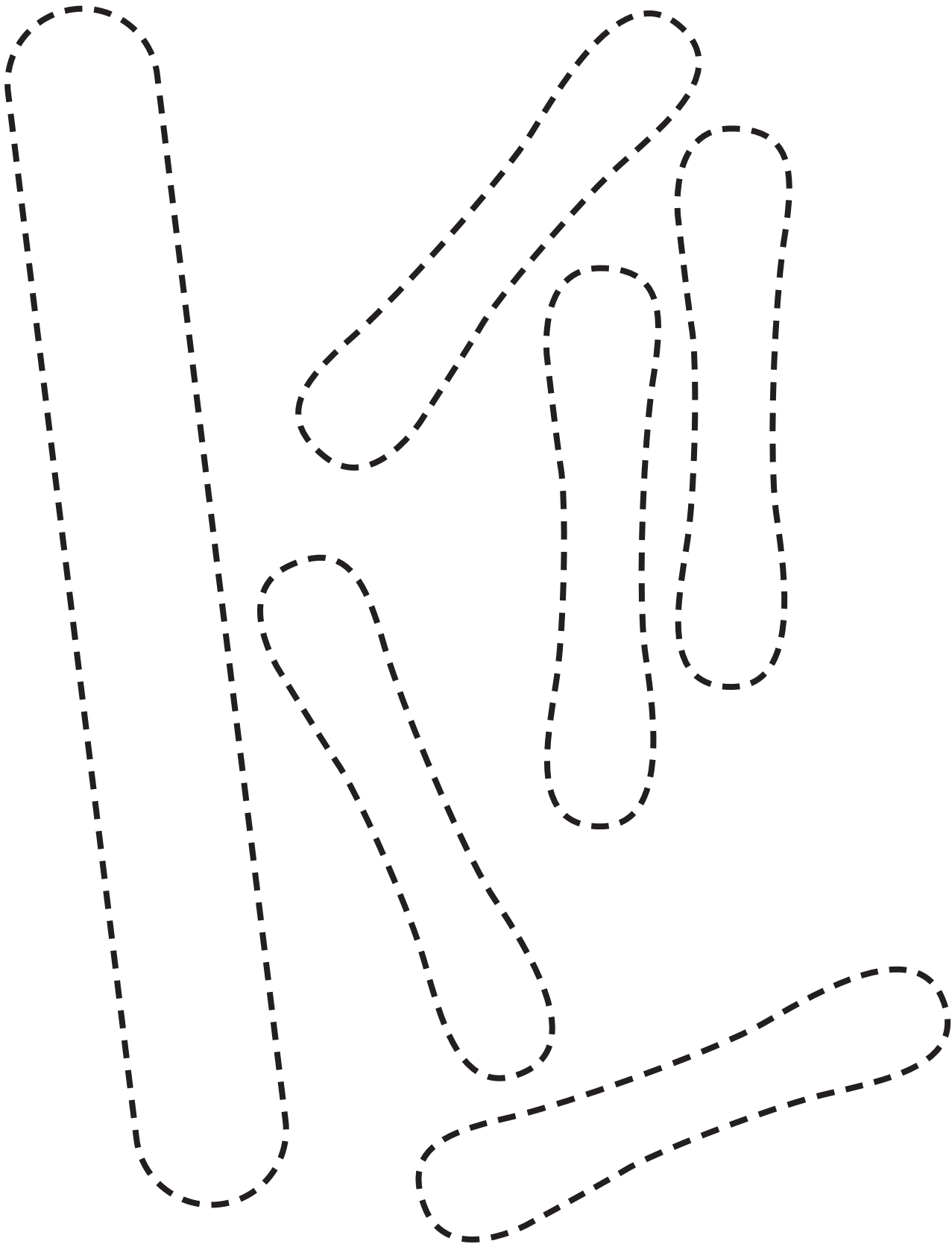

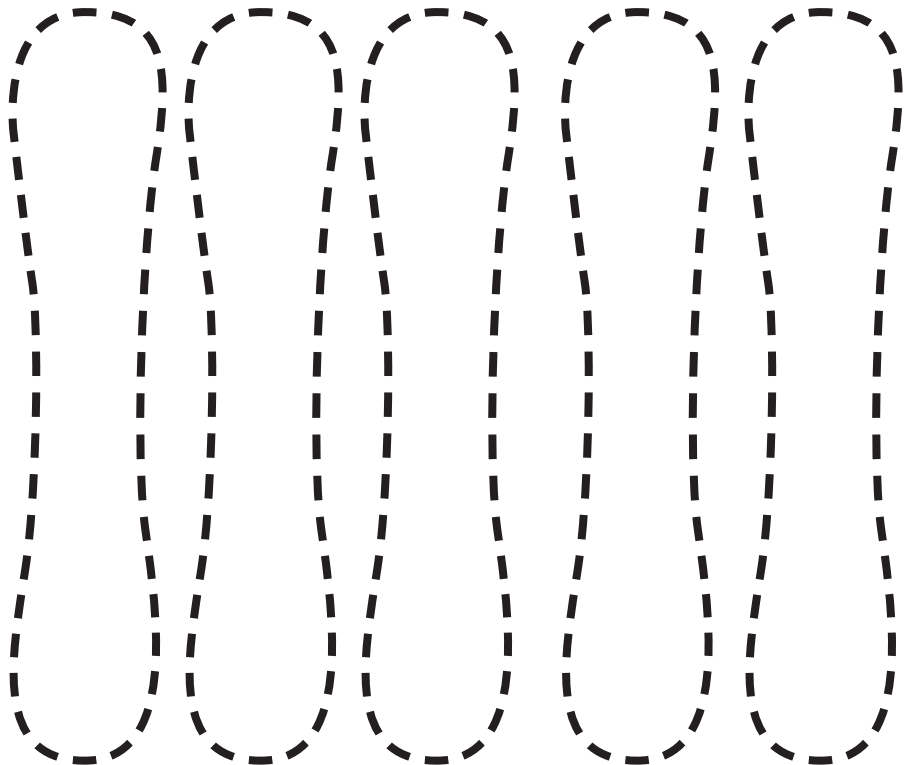
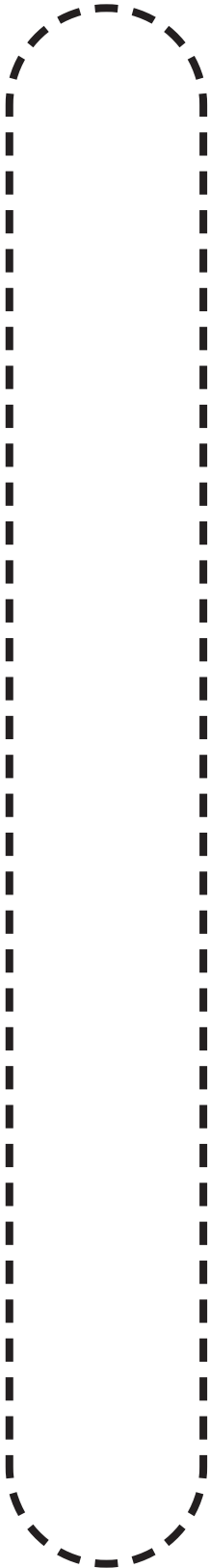

K3

1

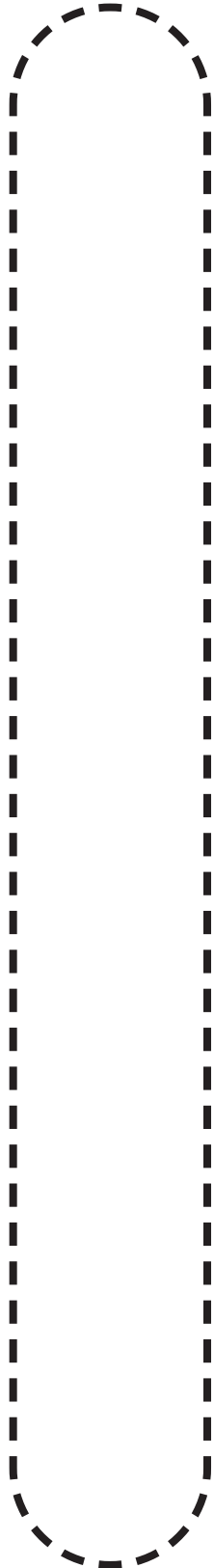

5



K4

