

# VL100 Voltage Logging Test Station

Pipeline DC Potential, Polarized Off Potential, AC Voltage  
Verify efficiency of applied cathodic protection, critical bond performance etc.

## FEATURES

Complete instrumented test station (Big Fink or customized)

Verification of CP efficiency

Easy installation – long battery life – solar option

Remote Monitoring – operate from Web or App

Cellular or Satellite

GPS time synchronization

Data presentation, analysis, reporting in CP\*Manage Web

## MEASUREMENTS

- ✓ Pipeline DC potential
- ✓ Polarized (Off) potential
- ✓ AC voltage
- ✓ Shunts



## DESCRIPTION

The MetriCorr VL100 is a unit for remote monitoring and data logging which is used for DC potential readings, polarized (“off”) potential readings, AC voltage readings, or for monitoring of critical bond currents across a shunt resistor.

The MetriCorr VL100 test station is part of a complete remote monitoring system for pipelines and associated components like T/R’s, line current spans, critical bonds, ER probes for corrosion rate measurements, interference loggers, etc.

Like the rest of the MetriCorr Slimline product family, the VL100 is intended as a remote monitoring unit (RMU), a data logging device, or simply as a spot reading device. It may be operated through the MetriCorr CP\*Manage Web or through the MetriCorr iOS/Android App. Data is sent to the CP\*Manage Web for easy reporting and analyzing or uploaded through the MetriCorr App and e-mailed to be processed by Excel (or similar) according to specific user needs.

The GPS time synchronization and designed measurement cycle ensures the possibility of getting “ON” readings as well as “instant OFF” readings synchronized with rectifier switch-off. User defined delay after switch-off is offered within the range of 120ms to 3s.

The Slimline product family fits into Big Fink test stations, MetriCorr test stations, junction boxes, or may be customized to fit into the operators’ preferred embodiment.

Robust surge protection based on spark gaps for high surge current handling:

- Eliminates the risk of leakage current and measurement errors
- Eliminates high voltage isolation requirements



# Technical specifications - VL100

|  |   |                                      |
|--|---|--------------------------------------|
| <b>Storage capacity</b>                              | +200 000 readings   |                                      |
| <b>Logging interval</b>                              | 10 min – ∞, Typically 1 hour<br>1s (intensive mode)   |                                      |
| <b>Power supply</b>                                  | 6 to 15 VDC (Max. 200mA @ 12VDC)<br>Battery module (Optional, as shown)   |                                      |
| <b>Battery Lifetime</b>                              | +3 years @ hourly logging, weekly upload<br>+10 years @ 6 times daily logging   |                                      |
| <b>Casing Humidity Temperature</b>                   | IP65<br>0 to 100% RH condensing conditions<br>-40°C to +85°C  |                                      |
| <b>Test Station Options</b>                          | <ul style="list-style-type: none"> <li>- Big Fink (Solar/Battery powered, see page 1)</li> <li>- Junction box (Solar/battery powered)</li> <li>- Junction box (AC supply 100–240VAC with surge protection)</li> <li>- MetriCorr Type Test Station</li> <li>- Customer's own specifications</li> </ul> |                                      |
| <b>Size L x W x H, weight</b>                        | 250 x 68 x 81 mm, 390 g   |                                      |
| <b>Communication</b>                                 | <ul style="list-style-type: none"> <li>- LTE Cat. 1 - 4G/5G with 2G/3G fall back</li> <li>- Satellite (optional)</li> <li>- Android or iOS App - Bluetooth</li> <li>- Ethernet (optional)</li> <li>- GPS Time Synchronization</li> <li>- GNSS (Position)</li> </ul>                                   |                                      |
| <b>Measurements</b>                                  | Input resistance  | +10.0 MΩ                             |
|  | Range   | ± 100 V / 100 Vrms                   |
|  | Resolution  | 0.1 mV DC / 1 mV AC                  |
|  | DC accuracy   | ± 0.8 mV ± 0.3% read.                |
|  | AC accuracy   | ± 1 mV ± 1% reading                  |
|  | AC to DC rejection  | -80 dB                               |
| <b>Surge Protection</b><br>EN/ISO 61000-4-5, class 4 | Nom. discharge current  | 10 kA @ 8/20 μs                      |
|  | Lightning impulse current   | 2.5 kA @ 10/350 μs                   |
|  | Optional (Pipe-Reference)   | 50 kA @ 8/20 μs<br>50 kA @ 10/350 μs |

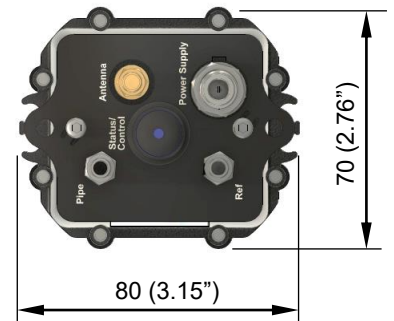
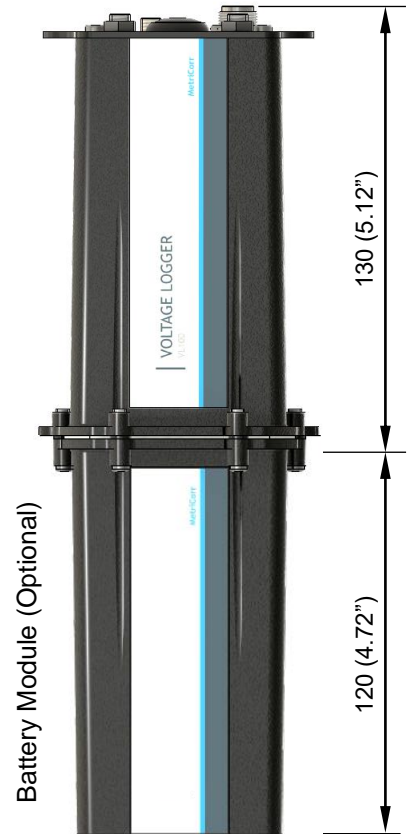

## VL100 INSTALLATION EXAMPLES

