

XL³ 125 Cabinets

Cat. No(s) : 4016 31/32/33/34/41/42/43/44

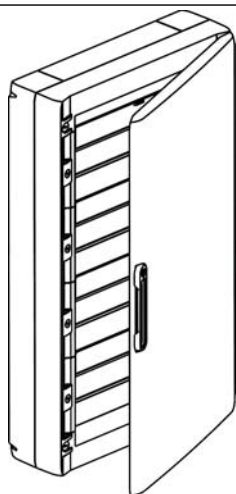

4 x 18M 4016 49

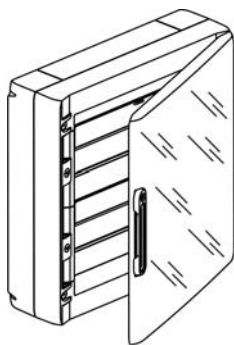

2 x 18M 4016 57

CONTENTS

PAGES

1. Description, use	1
2. Range	1
3. Overall dimensions	1
4. General characteristics	2
5. Compliance and approvals	2
6. Equipment and accessories	2-3-4

1. DESCRIPTION, USE

XL³ 125 cabinets from 1x18 modules to 4x18 modules

- Removable faceplates
- Removable, pivoting chassis
- Centre distance between rails 150 mm
- Accepts perforated plates and plain faceplates to mount non-modular products
- Attachments for Mosaic Programme wiring devices on the side of the cabinet
- Lockable door handle
- Door and cabinet are fully reversible

2. RANGE

Cat. No.	Number of rows	Number of modules
4016 31/41	1	18
4016 32/42	2	36
4016 33/43	3	54
4016 34/44	4	72

3. OVERALL DIMENSIONS

Front face

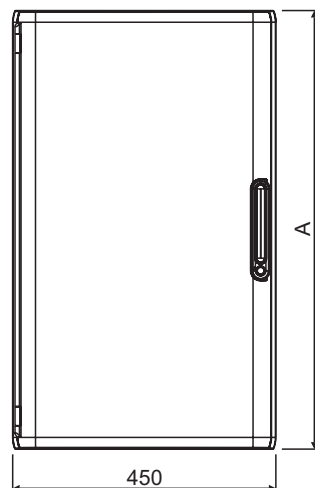

Side view

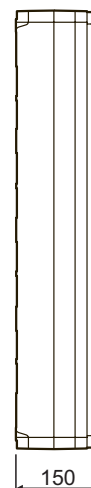

Fixing centre distances and distance between rails

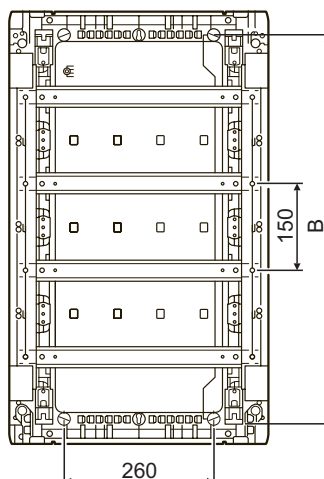

Cabinet Cat. No.	A (mm)	B (mm)
4016 31/41	300	250
4016 32/42	450	365
4016 33/43	600	515
4016 34/44	750	665

4. GENERAL CHARACTERISTICS

4.1 Technical characteristics

- Box and cover colour :White RAL 9003
- Protection index : IP40 - IK09
- Self-extinguishing : 650°C
- Classe II double insulation
- Rated operating voltage : 400V AC - 50/60 Hz
- Rated insulation voltage : 400V AC - 50/60 Hz
- Short circuit current : 10 kA
- Storage temperature : -20°C to +70°C
- Operating temperature : -10°C to +60°C
- Maximum admissible current :
 - 4016 31/41 : 63 A
 - 4016 32/42 : 90 A
 - 4016 33/43 : 125 A
 - 4016 34/44 : 125 A

4.2 Materials

- Box, cover, faceplate, terminal block support, open-work plate : resistant reinforced polystyrene.
- Rails supports, pivot-bolt, screw, cover ¼ turn fixinx : glass fibre-reinforced polycarbonate.
- Door, hinge, label holder, rod, guide: polycarbonate.
- Rails and metal uprights : galvanised steel.

4.3 Terminal block capacity and number of blanking plates

Cabinet Cat. No.	Auto. terminal 1,5 to 4 mm ²	Screw-type terminals	
		6 to 25 mm ²	6 to 35 mm ²
4016 31/41	18	5	-
4016 32/42	27	5	-
4016 33/43	36	5	-
4016 34/44	45	5	5

Cabinet Cat. No.	Number of blanking plates 5 modules
4016 31/41	1
4016 32/42	2
4016 33/43	3
4016 34/44	3

5. COMPLIANCE AND APPROVALS

NF EN 60 439-3
 NF EN 60 670-24
 RoHS
 WEEE
 REACH

CB Certificate

6. EQUIPMENT AND ACCESSORIES

6.1 Mounting support for Mosaic Programme wiring devices Cat. No. 4018 50

1 mounting supplied in cabinet

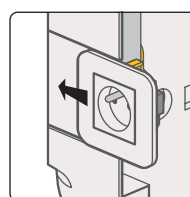

6.2 Guide ties

Guide ties supplied with the cabinet

Cat. No.	Number of ties
4016 31/41	0
4016 32/42	2
4016 33/43	3
4016 34/44	4

6.3 Key barrel Cat. No. 4018 51

Key barrel No. 850

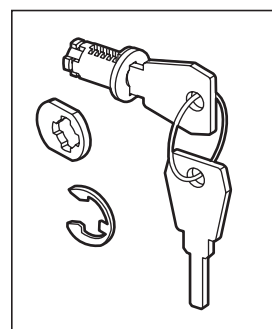

6.4 Joining kit Cat. No. 4018 45

Enables the association of 2 cabinets of the same size or of different sizes horizontally or vertically.

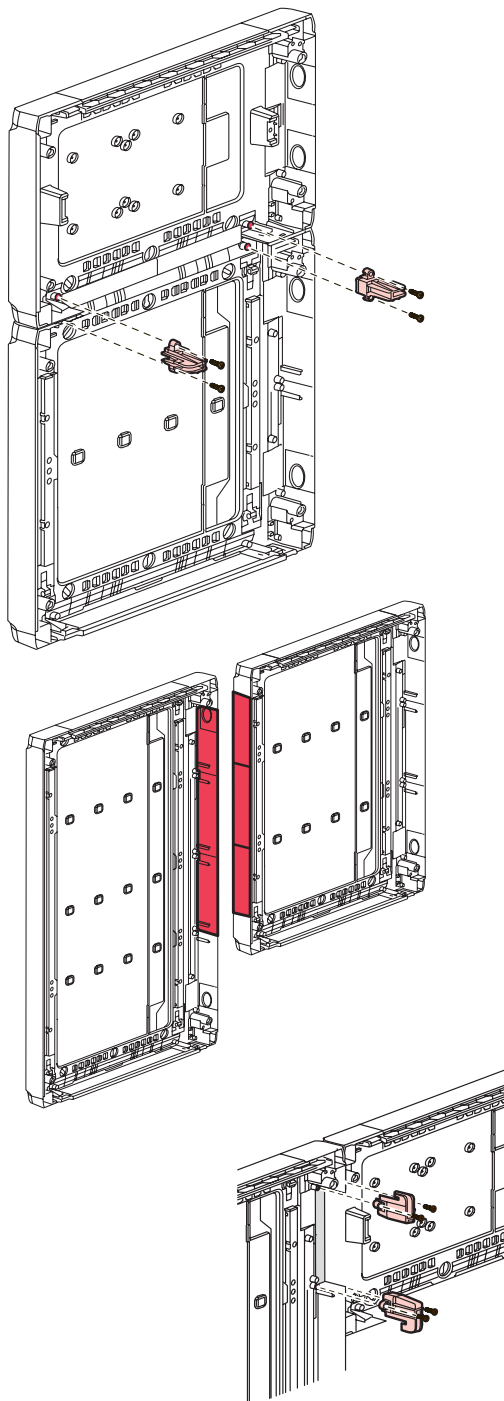
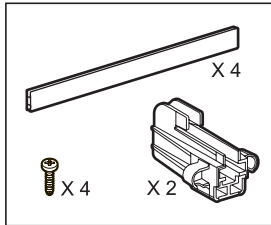

6.5 Set of 4 wall-mounting brackets Cat. No. 4018 56

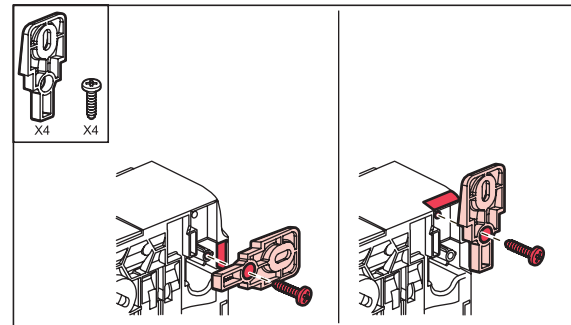

6.6 Blanking plates Cat. No. 016 60

5 modules, separable by module or half-module, white RAL 9010

6.7 Plain faceplate Cat. No. 4018 55

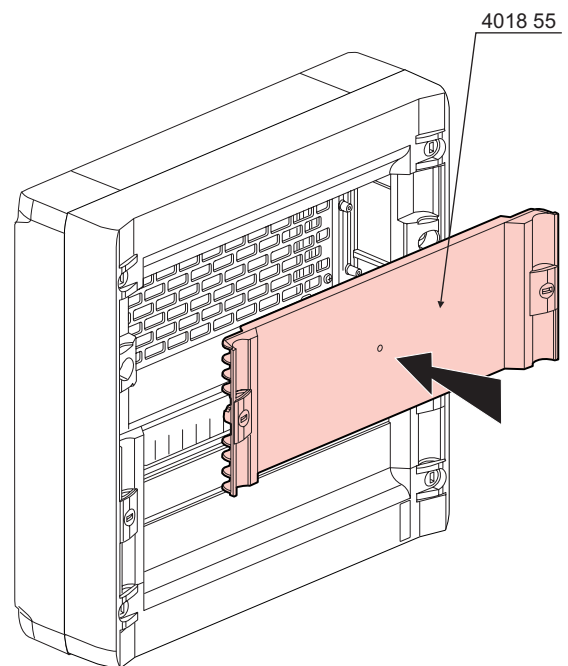

6.8 Perforated plate supplied with 4 fastening screws Cat. No. 4018 53

Enables replacement of DIN rail with LINA 25 plate to integrate non-modular products.

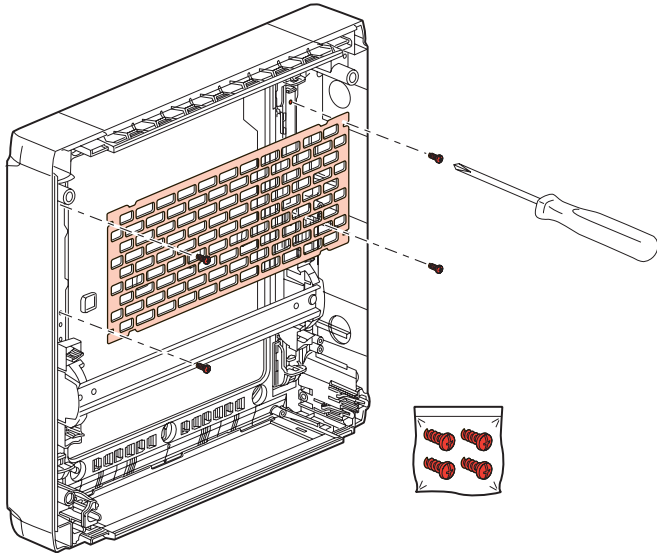

6.9 Documents holder Cat. No. 4018 44

