

# Verification level and communication

The validity of the results generated by our screening tool is naturally highly dependent on input data. Our tool is very complex on the inside and contains a huge amount of trustworthy data, but if one enters wrong-ful or lacking information about a product, the results will reflect it. Here we will explain how you may use your screening results, when they have been verified by Målbar.

## Verified by Målbar

If you choose to have a screening validated by Målbar, you are allowed to communicate the main result as long as you also mention and explain the range of the result. This means that the worst case and best case\* scenarios have to be communicated on an equal level as the main result. The three numbers are connected and may not be separated. The reason is that there is a potential of missing data, as the accuracy ultimately relies on the data provided by the brand owner. What Målbar does is to verify that the input data provided lies within the “normal” range and that all claims of sustainable aspects are documented. Additionally, you are allowed to use the results only internally and in B2B marketing, not in B2C relations.

Here is an example of how you may communicate a screening result on a product verified by Målbar in a B2B project report:

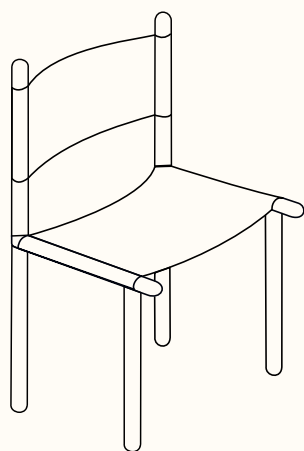

**Chair:**  
Aluminum base and recycled poly-  
ester seat and back

**Climate impact:**  
An estimated of 80 kg of CO<sub>2</sub>eq  
- with a range of +138%/-59%

*\*Worst case is if lacking data would turn out to be the worst they could be while best case represent the potential result if missing data would turn out to be the best case scenario.*

## Standard for calculation

This climate footprint report is calculated according to EU's rules for Product Environmental Footprint (PEF). When data was not available from the brand owner, conservative estimates has been applied. All phases of the product lifecycle are included in the calculation. For the phases after factory gate; Use Phase and Disposal, conservative estimates build from the PEF rules are applied. Specifically, the disposal is calculated based on an EU average. Målbar only reports on Climate Impact.

The data sources behind these calculations are: EcoInvent 3.8 and EF 3.0 and 3.1 PEF data as well as PEF compliant LCA data (read more here: [www.malbar.dk/transparency/](http://www.malbar.dk/transparency/)).

### Method of data application

This report is generated by using MÅLBAR's Climate Screening Tool with the brand owner first performing a self-assessment after which it has been validated and verified by Målbar.

### Responsibility of data

The brand owner has the sole responsibility concerning all input data (including: material and packaging weight and dimensions, origins of production and material, as well as transport, warehouse and retail information). Målbar has verified that input data are realistic for and cover the whole life cycle of this product type and that sustainability claims such as recycled polyester are documented correctly.

### Validity of the screening result

The results in this report are not intended for communication towards the private consumer (B2C) but only for the professional market (B2B). The screening is verified on the 15th of may 2023 and are valid for 1 year from this date. The screening has been performed in the Målbar software version 2.9612.

*It is mandatory to attach and display the above disclaimer in connection to the screening results provided by Målbar's screening tool*

### You cannot :

- Separate the main result from the best and worst case range – they have to be presented on the same page
- Avoid communicating the worst case scenario
- Say or write that the result is third party verified
- Say or write that the result is an official PEF result

When your screenings are verified by Målbar, a full project report including disclaimers will be provided to you.

