

### FIM 250 S A (Air cooled) + BIN 200

### FIM 250 S W (Water cooled) + BIN 200

- **Structure:** the ice maker is compound in 2 different modules, the ice making machine and the storage bin. Both the modules are realized completely in stainless steel 18/10 AISI 304. The bin is insulated to limit the melting of the ice stored and it is provided with a special sensor that signal when this bin is full, and consequently stops the machine itself to produce ice
- **Feet:** Nr 4 made in stainless steel 18/10 AISI 304, adjustable in height for levelling
- **Door:** in the front part of the appliance is located the door plastic made that closes the storage bin
- **Water inlet and outlet:** both located in the rear part of the appliance. The water inlet is 3/4" size, while the water outlet is 24 mm Ø. Both the pipes for the water inlet and outlet are included in the machine, the one for the inlet is about 100 cm long, while the outlet is about 40 cm
- **Kind of ice:** flake
- **Production (Kg/24h):** 250
- **Bin capacity (Kg):** 200
- **Cooling unit:** incorporated into the ice making machine module, with the condensing unit compounded by Nr 1 hermetic compressor and Nr 1 finned condenser, air cooled through a fan, in the version "A" or Nr 1 condenser, water cooled, in the version "W". Also, the motor compartment, incorporates the special evaporator with the screw with no end that crush the ice once formed, and automatically release it into the storage bin. All the mounted components are industrial grade to grant the maximum reliability
- **Water consumption (litres/Kg):** 1 (version A), 5,2 (version W)
- **Refrigerant:** R452A CFC-free
- **Voltage (V/ph/Hz):** 220-230/1/50
- **Breakers:** Nr 1 glass cartridge fuse with a rating of 10A, at protection of the appliance
- **Noise level (dB(A)):** ≤ 52
- **Dimensions (W x D x H cm):** 87 x 79 x 170
- **Net weight (Kg):** 160
- **Packed dimensions (W x D x Hcm):**  
ICE MAKER : 70 x 54 x 94 (0,36 m<sup>3</sup>)  
STORAGE BIN : 92 x 84 x 121 (0,94 m<sup>3</sup>)
- **Gross weight (Kg):** 185

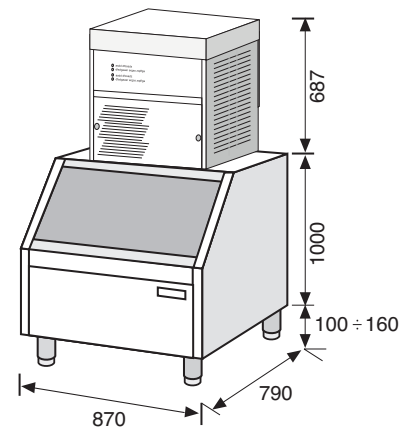

# FLAKE ICE MAKER

## ACCESSORIES AVAILABLE



Natural refrigerant R290



**230V / 60 Hz** Different voltage



**115V / 60 Hz** Different voltage

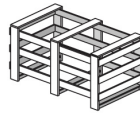

Wooden crate packing



ISO 9001:2015



EN ISO 13485:2016



VERS. 07.21

\* The declared performances are referred at +26°C ("A" version) and +32°C ("W" version) ambient temperatures, relative humidity of 70% and +16°C water temperature.

\* Should it be necessary or useful without undermining any model essential features, technical and stylistic characteristics are subject to be changed without manufacturer's previous notice.

N-Wissen GmbH

info@lab-wissen.de;

Tel: +49 (0) 69 8900 4008;

Fax: +49 (0) 69 8900 4007

Ferdinand-Porsche-Str. 2, 63073 Offenbach - Germany