

Robot[®]

Roomba Combo[™]

Robot Vacuum & Mop

Robot aspirateur et laveur

Robot aspirador y trapeador

j7+

Owner's Guide

Guide du propriétaire

Guía del usuario

Safety Information

Important Safety Information

This owner's guide includes information for Regulatory Model(s):
Robot: RCA-Y1 | Dock: ADG-N1 | Battery: ABL-F | Radio Module: AXG-Y1

SAVE THESE INSTRUCTIONS

 **WARNING:** When using an electrical appliance, basic precautions should always be followed, including the following:

READ ALL INSTRUCTIONS

 **WARNING:** To reduce the risk of injury or damage, read and follow the safety precautions when setting up, using and maintaining your robot.

This appliance can be used by children aged from 8 years and above and persons with reduced physical, sensory or mental capabilities or lack of experience and knowledge if they have been given supervision or instruction concerning use of the appliance in a safe way and understand the hazards involved. Children shall not play with the appliance. Cleaning and user maintenance shall not be made by children without supervision.

 This is the safety alert symbol. It is used to alert you to potential physical injury hazards. Obey all safety messages that follow this symbol to avoid possible injury or death.

 Risk of electric shock

 Class II equipment

 Rated power output, d.c.

 Read operator's manual

 General symbol for recycling

 Risk of fire

 For indoor use only

 Rated power input, d.c.

 Keep out of reach of children

 Separate Supply Unit

 Caution

 Rated power input, a.c.

WARNING: Indicates a hazardous situation that, if not avoided, could result in death or serious injury.

CAUTION: Indicates a hazardous situation that, if not avoided, could result in minor or moderate injury.

NOTICE: Indicates a hazardous situation that, if not avoided, could result in property damage.

GENERAL



WARNING

- Your robot comes with a region approved power supply cord and is designed to be plugged into a standard household AC power outlet only. Do not use any other power supply cord. For replacement cords, please contact Customer Care to ensure proper selection of country specific power supply cord.
- Do not submerge your robot in water.
- Do not open your robot except as instructed to install or replace the battery or to perform required maintenance. Do not open the integrated dock-charger known as Home Base or Clean Base. There are no user serviceable parts inside. Refere servicing to qualified service personnel.
- Risk of electric shock, use indoors in dry location only.
- Do not handle your robot or charging station with wet hands.
- Do not use unauthorized chargers. Use of an unauthorized charger could cause the battery to generate heat, smoke, catch fire, or explode.
- Your robot is not a toy. Small children and pets should be supervised when your robot is operating. Do not sit or stand on your robot or dock.
- Store and operate your robot in room temperature environments only.
- If the room to be cleaned contains a balcony, a physical barrier should be used to prevent access to the balcony and ensure safe operation.
- Clean the (edge detection or cliff) sensors lens and covers on the bottom of your robot for dust and dirt buildup as needed.
- If the room to be cleaned contains equipment, such as a stove, fan, or humidifier, remove the equipment before operation. There is a risk of injury, accident or malfunction if the robot comes in contact and pushes the equipment.
- Do not use the mopping pad plate as a handle to lift or move the robot.
- Be aware that floors may be slippery after wet cleaning with your robot.
- Do not operate the robot in areas with exposed electrical outlets in the floor.



CAUTION

- Do not use this device to pick up sharp objects, glass, or anything that is burning or smoking.
- Be aware that the robot moves on its own. Take care when walking in the area that the robot is operating in to avoid stepping on it.
- If the device passes over a power cord and drags it, there is a chance an object could be pulled off a table or shelf. Before using this device, pick up objects like clothing, loose papers, pull cords for blinds or curtains, power cords, and any fragile objects.
- Perform the required maintenance per the owner's guide to ensure safe operation of the robot and charging station.
- If the robot is operating on a floor with stairs, please remove any clutter from the top step.

NOTICE

- Do not allow your robot or charging station to become wet.
- Do not place anything on top of your robot.
- The failure to maintain cleanliness of charger contacts could result in loss of ability for the robot to charge the battery and the contacts to become hot to the touch.
- Before running your robot on hard floors, please test your robot on a small section of the hard floor to ensure that it is compatible. Using your robot on a hard floor that is not compatible could result in damage to your floor. Contact your hard floor manufacturer with questions on compatibility.
- Before running your robot on carpets or rugs, ensure that the carpets or rugs are compatible with vacuums using bars or brushes. Using your robot on a carpet or rug that is not compatible could result in damage to your carpet or rug. Contact your carpet or rug manufacturer with questions on compatibility.



BATTERY WARNING

- Do not open, crush, heat above 176°F: 80°C, or incinerate. Follow the owner's guide instructions for proper use, maintenance, handling, and disposal.
- Do not short-circuit the battery by allowing metal objects to contact

battery terminals or immerse in liquid. Do not subject batteries to mechanical shock.

- Lithium ion batteries and products that contain lithium ion batteries are subject to stringent transportation regulations. If you need to ship this product (with the battery included) for service, travel or any other reason, you must see the Troubleshooting section of your owner's guide or contact customer care for shipping instructions.
- Periodically inspect the battery pack for any sign of damage or leakage. Do not charge damaged or leaking battery packs, do not allow the liquid to come in contact with skin or eyes. If contact has been made, wash the affected area with copious amounts of water and seek medical advice. Place the battery in a sealed plastic bag and recycle or dispose of safely according to local environmental regulations, or return it to your local authorized iRobot Service Center for disposal.
- Keep battery pack clean and dry. Wipe the cell or battery terminals with a clean dry cloth if they become dirty.



CAUTION

- Battery usage by children should be supervised. Seek medical advice immediately if a cell or a battery has been swallowed.

NOTICE

- The battery pack must be removed from the robot before recycling or disposal.
- For best results, only use the iRobot Lithium Ion Battery that comes with the robot.
- Do not use non-rechargeable batteries. Use only the rechargeable battery supplied with the product. For replacement, purchase identical iRobot battery or contact iRobot Customer Care for alternative battery options.
- Always charge and remove the battery from your robot and accessories before long-term storage.

CLEANING SOLUTION



WARNING

- Household cleaning products are safe when used and stored according to the instructions on the label. Always be sure to read and follow the directions carefully.

- Only use authorized cleaning solution found on answers.irobot.com/s/roomba-combo-cleanser.
- For cleaning solution warnings, please refer to outer box and solution bottle



Keep away from children



Rinse hands after use



Keep away from eyes.
If product gets into eyes rinse thoroughly with water



AUTOMATIC DIRT DISPOSAL

WARNING



- Do not use with damaged cord or plug. If appliance is not working as it should, has been dropped, damaged, left outdoors, or dropped into water, return it to a service center.
- Always disconnect your robot from the dirt disposal before cleaning or maintaining it.
- Charge your robot only with the power supply provided. The provided power supply delivers safety extra low voltage corresponding to the input marking on the robot which is required to maintain safe operation.
- Do not put any object into openings. Do not use with any opening blocked; keep free of dust, lint, hair, and anything that may reduce air flow.
- To prevent the risk of your robot falling downstairs, ensure that the charging station is placed at least 4 feet (1.2 meters) away from stairs.
- To properly maintain your dirt disposal, do not place foreign objects in your Automatic Dirt Disposal Port and ensure it is clear of debris.
- In order to avoid a hazard due to inadvertent resetting of the thermal cut-out, this appliance must not be supplied through an external switching device, such as a timer, or connected to a circuit that is regularly switched on and off by the utility.
- Do not pour any liquids into the device and do not immerse in water.
- Do not allow liquids to get on or into the dirt disposal.
- Do not use outdoors or on wet surfaces.

- Do not allow to be used as a toy. Close attention is necessary when used by or near children.
- In order to avoid a hazard due to inadvertent resetting of the thermal cut-out, this appliance must not be supplied through an external switching device, such as a timer, or connected to a circuit that is regularly switched on and off by the utility.
- Use only as described in this manual.
- To reduce the risk of electric shock, unplug your dirt disposal before cleaning.
- Keep the dirt disposal and power cord away from heated surfaces.

CAUTION

- Only charge the battery that came with your robot. Other types of batteries may burst causing injury. Always contact iRobot Customer Care for the correct replacement of your battery.

NOTICE

- Product may not be used with any type of power converter. Use of power converters will immediately void the warranty.
- If you live in an area prone to electrical storms, it is recommended that you use additional surge protection. Your dirt disposal may be protected with a surge protector in the event of severe electrical storms.
- Do not use without dust bag and/or filters in place, or rugs are compatible with vacuums using bars or brushes. Using your robot on a carpet or rug that is not compatible could result in damage to your carpet or rug. Contact your carpet or rug manufacturer with questions on compatibility.



This symbol on the battery indicates that the battery must not be disposed of with unsorted common municipal waste. As the end-user, it is your responsibility to dispose of the end-of-life battery in your appliance in an environmentally sensitive manner as follows:

- (1) Returning it to the distributor/dealer from whom you purchased the product or
- (2) Depositing it at a designated collection point

The separate collection and recycling of end-of-life batteries at the time of disposal will help to conserve natural resources and to ensure that it is recycled in a manner that protects human health and the environment. For more information, please contact your local recycling office or the dealer from whom you originally purchased the product. Failure to properly dispose of end-of-life batteries may result in negative potential effects on the environment and human health due to the substances in the batteries and accumulators.



For battery recycling go to call2recycle.org or call 1-800-822-8837

About your Roomba Combo™ Robot Vacuum & Mop

Top View

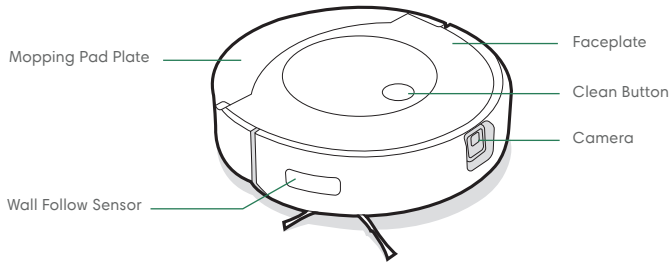

Bin

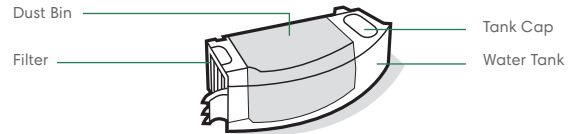

Bottom View

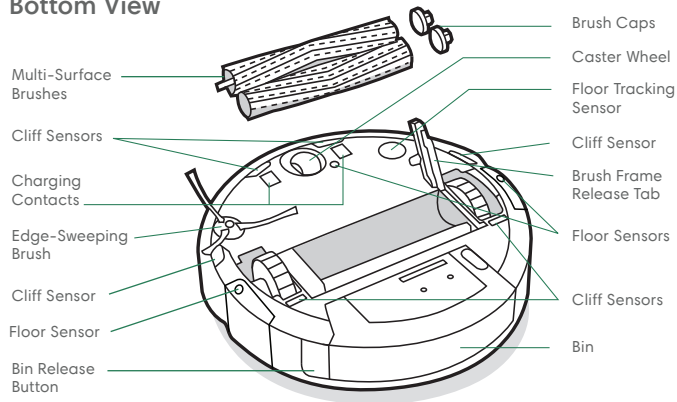

About Your Clean Base™ Automatic Dirt Disposal

EN

Front View

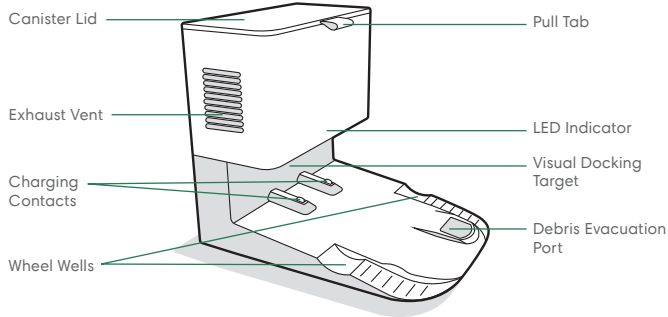

Back View

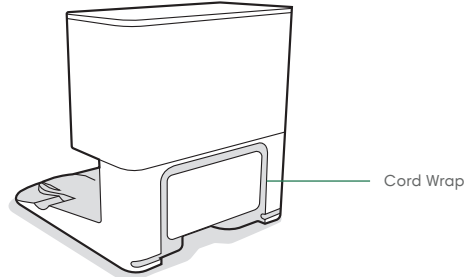

Top View

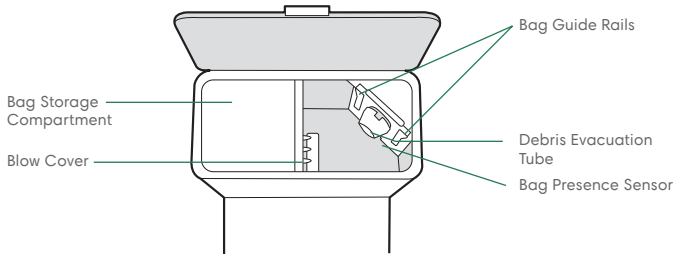

Bottom View

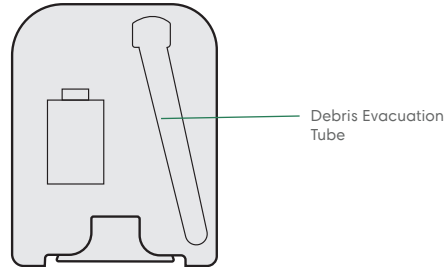

Using Your Roomba Combo™ Robot Vacuum & Mop

Positioning the Clean Base™ Automatic Dirt Disposal

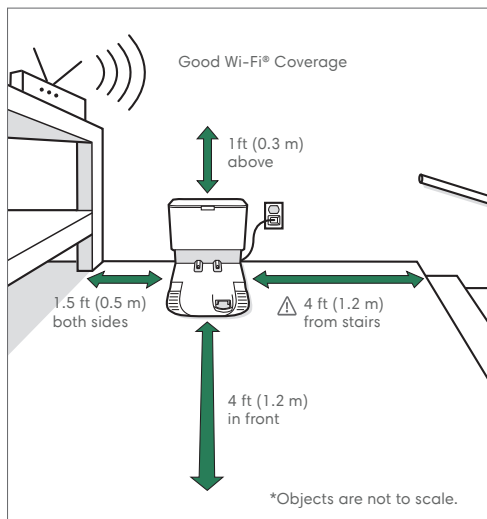

Note: Do not place your Clean Base™ in direct sunlight. Ensure the area around the dock is free of clutter to improve docking performance.

WARNING: To prevent the risk of your robot falling downstairs, ensure that the charging station is placed at least 4 feet (1.2 meters) away from stairs.

Download the iRobot Home App and Connect to Wi-Fi®

- Follow step-by-step instructions to set up your Roomba Combo™.
- Set up PrecisionVision Navigation to avoid obstacles in real time.
- Set an automatic cleaning schedule and customize cleaning preferences.
- Create smart maps to tell your robot where, when and how to clean.



Charging

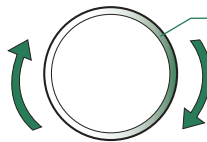

Light Ring Spiral While Charging

White Spiral: charging

A solid white light will indicate the battery charge percentage of your robot

- Place the robot on the charging station to activate the battery.
- **Note:** Your robot comes with a partial charge, but we recommend that you charge the robot for 3 hours prior to starting the first cleaning job.

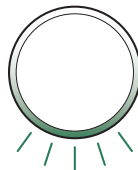

When your robot is fully charged, the light ring indicator will intermittently pulse white at the rear.

- The robot uses a small amount of power whenever it is on the charging station. You can put the robot in a further-reduced power state when not in use. For instructions and more details on this Reduced Power Standby Mode, refer to the FAQ page on our website.
- For long-term storage, turn off the robot by removing it from the charging station and holding down the clean button for 3 seconds with one wheel off the ground. Store the robot in a cool, dry place.

Cleaning

EN

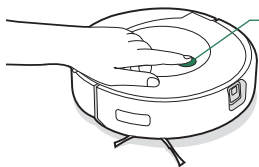

Just press the clean button
Tap to Start / Pause / Resume
Hold for 2-5 seconds to end a job

- Your robot will automatically explore and clean your home in neat rows, avoiding obstacles using its front-facing camera. It will return to the charging station at the end of a cleaning job and whenever it needs to recharge.



Your robot is able to recognize and avoid objects. However, it is still recommended to remove excess clutter before cleaning.

- To end a job and send the robot back to its charging station, hold the clean button down for between 2-5 seconds. A blue light ring pattern will indicate that the robot is seeking the charging station.
- When your robot detects an especially dirty area, it will engage Dirt Detect™ mode, moving in a forward/backward motion to clean the area more thoroughly. The light ring indicator will flash blue.



When your robot senses that its bin needs to be emptied, the light ring indicator will illuminate in a red sweeping motion toward the rear.

Vacuuming

- To start a vacuum-only cleaning job from your robot, empty the tank or detach the mopping pad before pressing the clean button.

Mopping

- Your robot is able both vacuum and mop at the same time. To start a vacuum and mop cleaning job from your robot, fill the tank, attach a mopping pad, and press the clean button.
- When your robot encounters carpet during its cleaning job, it will lift and tuck the mopping pad away.
- After completing your mopping and vacuum cleaning job, make sure to empty the water tank and replace the mopping pad.

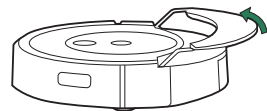

WARNING: To prevent damaging your robot, do not manually stow the mopping pad plate onto the pad shelf.

- 1** Press bin release button to remove bin.

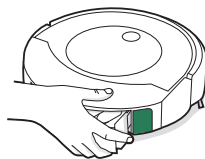

- 2** Fill tank with water and compatible cleaning solution.

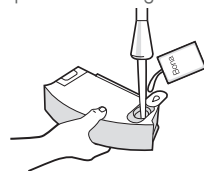

- 3** Attach mopping pad.

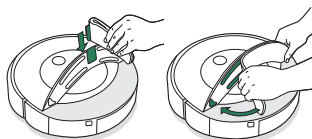

- 4** Place bin back in the robot.

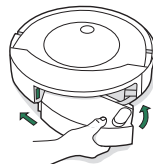

Cleaning Solution

For best results when mopping, use Bona® Hardwood or Hard-Surface Floor Cleaning Solutions. Both solutions are suitable for most well-sealed hard floors.



Sample Concentrate Packets

Included in box

1 Packet per tank
Mix to manufacture instruction
and pour into tank.



Retail Ready-to-Use Bottles

Sold separately

Fill the tank with cleaning solution. No
water is necessary.

Important: Only certain cleaning solutions can be safely used with your robot. A full list of compatible cleaning solutions can be found on [answers.irobot.com/s/roomba-combo-cleanser](https://www.irobot.com/s/roomba-combo-cleanser) or by visiting the app. Please do not use other cleaning solutions or bleach-based products.

About Your Automatic Dirt Disposal

While cleaning, your robot will automatically return to the dirt disposal to empty its bin and recharge as needed.

The dirt disposal's LED indicator will turn solid red when a new bag is needed. If a clog is detected, the dirt disposal will trigger additional attempts to automatically clear the clog.

Note: If you place your robot on the dirt disposal by hand, it will not empty automatically. In this case, use the iRobot Home App or hold the button down for 2-5 seconds.

Troubleshooting

- Your robot will tell you something is wrong by playing an audio alert and turning the light ring indicator red. Press the clean button or tap the bumper for details. Check the iRobot Home App for further support.
- After 90 minutes of inactivity off the charging station, the robot will automatically end its cleaning job.
- To factory reset your robot, remove the dust bin and hold the clean button down for seven (7) seconds. A sound will let you know when the factory reset has been completed. Press the clean button down once more to confirm.

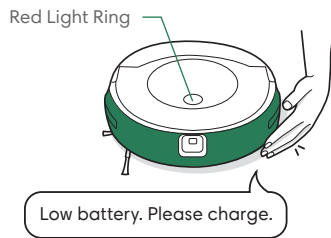

Battery Safety & Shipping

For best results, only use the iRobot Lithium Ion Battery that comes with your robot.

- WARNING:** Lithium ion batteries and products that contain lithium ion batteries are subject to stringent transportation regulations. If you need to ship this product for service, travel or any other reason, you **MUST** follow the below shipping instructions.
- Battery **MUST** be turned off before shipping.
- Turn off the battery by removing the robot from the charging station and holding down the clean button for 3 seconds with one wheel off the ground. All indicators will turn off.
- Package the robot securely for shipping.
- If you need further assistance, contact our Customer Care team or visit [global.irobot.com](https://www.global.irobot.com).

Troubleshooting Your Automatic Dirt Disposal

Your dirt disposal will tell you if something is wrong via an LED indicator on the front of the canister and through the iRobot Home app.

LED Indicator	Common Error	How to Fix
Solid Red	Bag full or missing	<ol style="list-style-type: none"> 1. Replace bag if it is full or missing. 2. Make sure the bag is securely inserted. 3. If problem persists, remove any debris from the port on the bottom of your robot and the dirt disposal.
Blinking Red	There is a leak or a clog in the dock evacuation path	<ol style="list-style-type: none"> 1. Make sure the canister lid is pushed down and firmly sealed. Hold the clean button on your robot down for 2 seconds to manually empty the bin. 2. Remove any debris from the port on the bottom of your robot and dirt disposal. 3. Unplug the dirt disposal from the wall. Place it on its side and inspect the debris evacuation tube for debris. If necessary, remove the tube to clear any debris.

This product has been equipped with a thermal protector designed to protect against damage due to overheating. If the protector operates, the motor will stop running. If this happens, unplug the unit, allow to cool for 30 minutes, clear any obstructions from the evacuation port and evacuation tube, and plug the unit back in.

Care and Maintenance

Care and Maintenance Instructions

To keep your robot running at peak performance, perform the procedures on the following pages.

There are additional instructional videos in the iRobot Home App. If you notice the robot picking up less debris from your floor, empty the bin, clean the filter and clean the brushes.

Part	Care Frequency	Replacement Frequency*
Mopping Pad	Clean after a mopping job	After 30 washes.
Bin	Wash bin as needed	
Filter	Clean once a week (twice a week if you have a pet). Do not wash.	Every 2 months
Charging Contacts	Clean every 2 weeks	
Full Bin Sensor	Clean every 2 weeks	
Front Caster Wheel	Clean every 2 weeks	Every 12 months
Edge-Sweeping Brush and Multi-Surface Brushes	Clean once a month (twice a month if you have a pet)	Every 12 months
Sensor, Camera Window and Pad Shelf	Clean once a month	
Bags	-	Bags should be replaced when prompted by the LED indicator / app
Blower Cover inside canister	Once every month (remove debris from blower cover)	

 **Note:** iRobot manufactures various replacement parts and assemblies. If you think you need a replacement part, please contact iRobot Customer Care for more information.

*Replacement frequency may vary. Parts should be replaced if visible wear appears.

Cleaning the Mopping Pad

 **Note:** You can clean your mopping pads two ways: either by hand washing, or in a washing machine.

HAND WASHING

Thoroughly wash the pad with warm water.

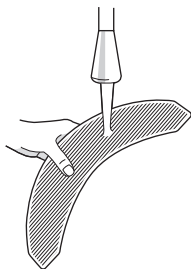

MACHINE WASHING

Wash using the warm cycle, then air dry. Do not put in dryer. Do not wash with delicates.

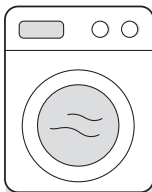

Emptying the Bin

1 Press bin release button to remove bin.

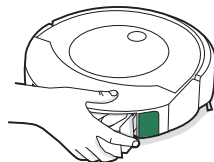

2 Open bin door to empty bin.

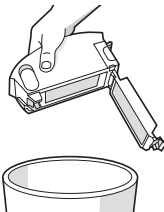

3 Place bin back in the robot.

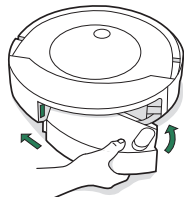

Cleaning the Filter

1 Remove the bin. Remove the filter by grasping both ends and pulling out.

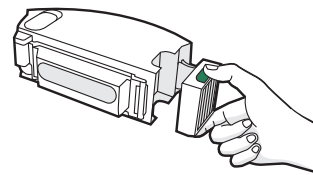

2 Remove debris by tapping the filter against your trash container.



3 Reinsert filter with ridged grips facing out. Place bin back in the robot.

 **Important:** The robot will not run if the filter is not installed correctly. Replace the filter every two months.

Cleaning the Charging Contacts

- 1 Wipe the charging contacts with a clean, dry cloth.

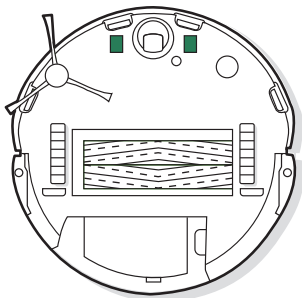

Cleaning the Full Bin Sensors

- 1 Remove and empty the bin.

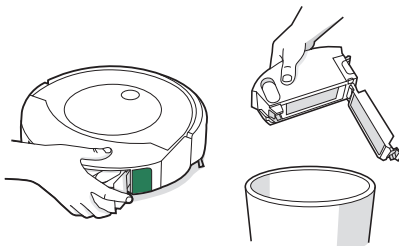

- 3 Wipe the bin door with a clean, dry cloth.

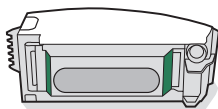

Closed Door

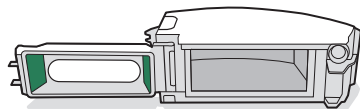

Opened Door

- 2 Wipe the inner sensors with a clean, dry cloth

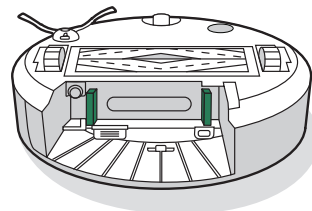

- 4 Clear any debris from the vacuum path.

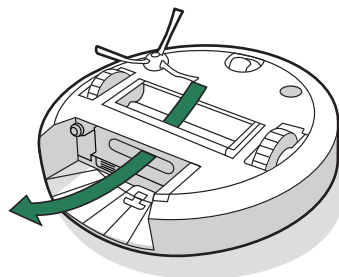

Cleaning the Multi-Surface Brushes

- 1 Pinch the brush frame release tab, lift the tab, and remove any obstructions.

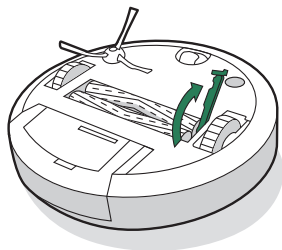

- 3 Remove any hair or debris from the square and hexagonal pegs on the opposite side of the brushes.

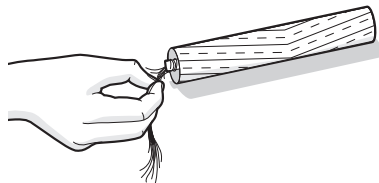

- 2 Remove the brushes from the robot. Remove the brush caps from the ends of the brushes. Remove any hair or debris that has collected beneath the caps. Reinstall the brush caps.

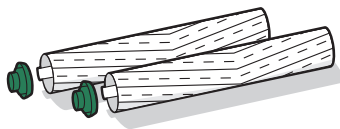

- 4 Reinstall the brushes in the robot. Match the shape of the brush pegs with the shape of the brush icons in the cleaning head module.

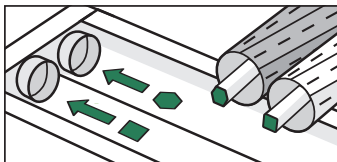

Cleaning the Front Caster Wheel

- 1 Pull firmly on the front wheel module to remove it from the robot.
- 2 Pull firmly on the wheel to remove it from its housing (see illustration below).
- 3 Remove any debris from inside the wheel cavity.
- 4 Reinstall all parts when finished. Make sure the wheel clicks back into place.

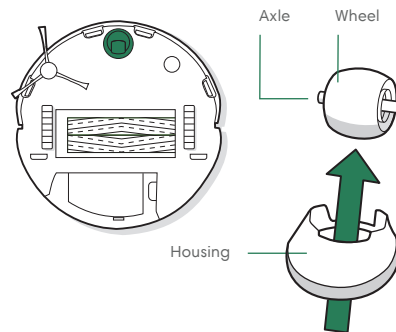

*** Important:** A front wheel clogged with hair and debris could result in damage to your floor. If the wheel is not spinning freely after you have cleaned it, please contact Customer Care.

Cleaning the Filter

*** Important:** Do not wash the filter. Remove the filter before washing the bin.

1 Release the bin, remove the filter, and open the bin door.

2 Rinse the dust bin and water tank using warm water.

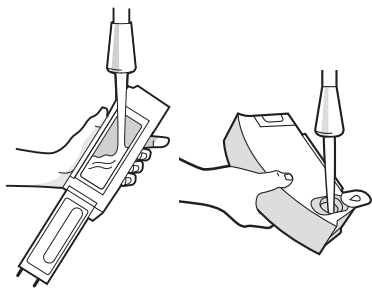

Note: Bin is not dishwasher safe.

3 Make sure bin is completely dry. Reinsert filter and place bin back in the robot.

Cleaning the Edge-Sweeping Brush

1 Use a coin or small screwdriver to remove the screw holding the Edge-Sweeping Brush in place.

2 Pull to remove the Edge-Sweeping Brush. Remove any hair or debris, then reinstall the brush.

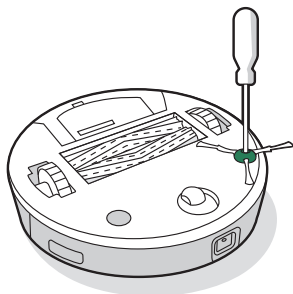

Cleaning the Sensors, Camera Window and Charging Contacts

1 Wipe sensors, camera window and pad shelf with a clean, dry cloth.

Note: You can clean your mopping pads two ways: either by hand washing, or in a washing machine.

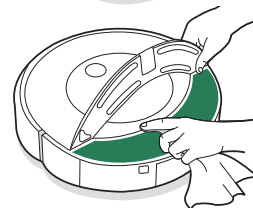
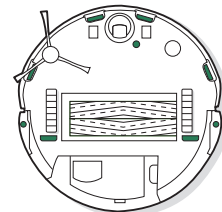
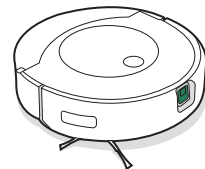

*** Important:** Do not spray cleaning solution or water onto the sensors or sensor openings.

Replacing the Bag

- 1 Lift up on the canister lid to open.

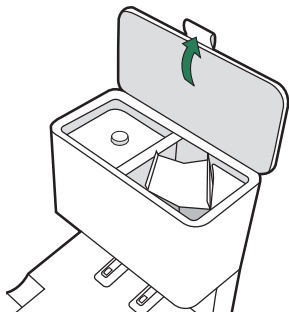

- 2 Discard the used bag.

 **Note:** This will seal the bag so dust and debris cannot escape.

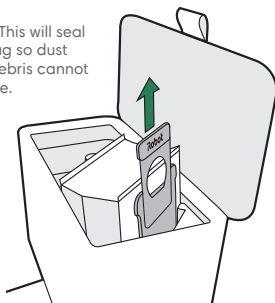

- 3 Pull up on the plastic card to remove the bag from the canister.

- 4 Install a new bag, sliding the plastic card into the guide rails.

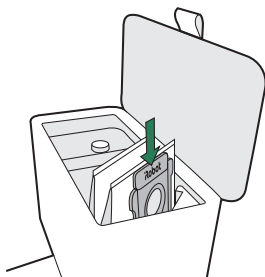

- 5 Press down on the lid making sure it is completely closed.

 **Note:** To achieve optimal performance with your robot and automatic dirt disposal, clean and/or replace your robot's filter as needed.

Removing Debris from Blower Cover

Inspect blower cover for any lint or debris built-up and wipe with a clean dry cloth to remove.

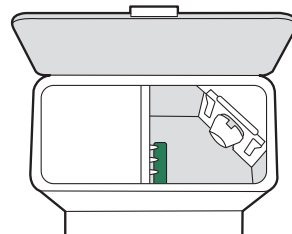

EN

iRobot Customer Care

USA & Canada

If you have questions or comments about your dirt disposal, please contact iRobot before contacting a retailer.

You can start by visiting global.irobot.com for support tips, frequently asked questions, and information about accessories. This information can also be found in the iRobot HOME App. If you need further assistance, call the US Customer Care team at (877) 855-8593.

iRobot USA Customer Care Hours

Monday to Friday, 9AM — 9PM Eastern Time

Saturday and Sunday 9AM — 6PM Eastern Time

Outside USA & Canada

Visit global.irobot.com to:

Learn more about iRobot in your country

Get hints and tips to improve your product performance

Get answers to questions

Contact your local support center

Regulatory Information

FCC Supplier's Declaration of Conformity

iRobot Corporation

Roomba Model: RCA-Y1

FCC ID: UFE-RCAY1

Contains FCC ID: UFE-AXGY1 and contains IC: 6652A-AXGY1

This device complies with part 15 of the FCC Rules and ICES-003.

Operation is subject to the following two conditions: (1) This device may not cause harmful interference, and (2) this device must accept any interference received, including interference that may cause undesired operation.

This device complies with Industry Canada license-exempt RSS standard(s). Operation is subject to the following two conditions: 1) This device may not cause interference, and 2) this device must accept any interference, including interference that may cause undesired operation of the device.

- Changes or modifications not expressly approved by iRobot Corporation could void the user's authority to operate the equipment.
- This equipment has been tested and found to comply with the limits for a Class B digital device, pursuant to part 15 of the FCC Rules as well as ICES-003 Rules. These limits are designed to provide reasonable protection against harmful interference in a residential installation. This equipment generates, uses and can radiate radio frequency energy and, if not installed and used in accordance with the instructions, may cause harmful interference to radio communications. However, there is no guarantee that interference to radio communication will not occur in a particular installation. If this equipment does cause harmful interference to radio or television reception, which can be determined by turning the equipment off and on, the user is encouraged to try to correct the interference by one or more of the following measures:
 - Reorient or relocate the receiving antenna.
 - Increase the separation between the equipment and receiver.
 - Connect the equipment into an outlet on a circuit different from that to which the receiver is connected.
 - Consult the dealer or an experienced radio/TV technician for help.

- Under Industry Canada regulations, this radio transmitter may only operate using an antenna of a type and maximum (or lesser) gain approved for the transmitter by Industry Canada. To reduce potential radio interference to other users, the antenna type and its gain should be so chosen that the equivalent isotropically radiated power (e.i.r.p.) is not more than the necessary for successful communication.
- FCC Radiation Exposure Statement: This product complies with FCC §2.1091(b) for mobile device RF exposure limits, set forth for an uncontrolled environment and is safe for the intended operation as described in this manual. Per FCC requirements, maintain a distance of more than 8 inches (20 cm) between any person and the host device (Roomba Combo robot).
- ISED Radiation Exposure Statement: This product complies with the Canadian Standard RSS-102 for mobile device RF exposure limits, set forth for an uncontrolled environment and is safe for the intended operation as described in this manual. Per ISED requirements, maintain a distance of more than 8 inches (20 cm) between any person and the robot.

iRobot Corporation, 8 Crosby Drive, Bedford, MA 01730 USA.
<https://global.irobot.com>

For battery recycling go to call2recycle.org;
or call 1-800-822-8837





©2022 iRobot Corporation, 8 Crosby Drive, Bedford, MA 01730 USA. All rights reserved. iRobot is a registered trademark of iRobot Corporation. Roomba Combo, Clean Base and Dirt Detect are trademarks of iRobot Corporation. Wi-Fi and the Wi-Fi logo are registered trademarks of Wi-Fi Alliance. Apple and App Store are trademarks of Apple Inc., registered in the U.S. and other countries. Google Play is a trademark of Google LLC. Bona is a registered trademark of Bona AB Corp.