

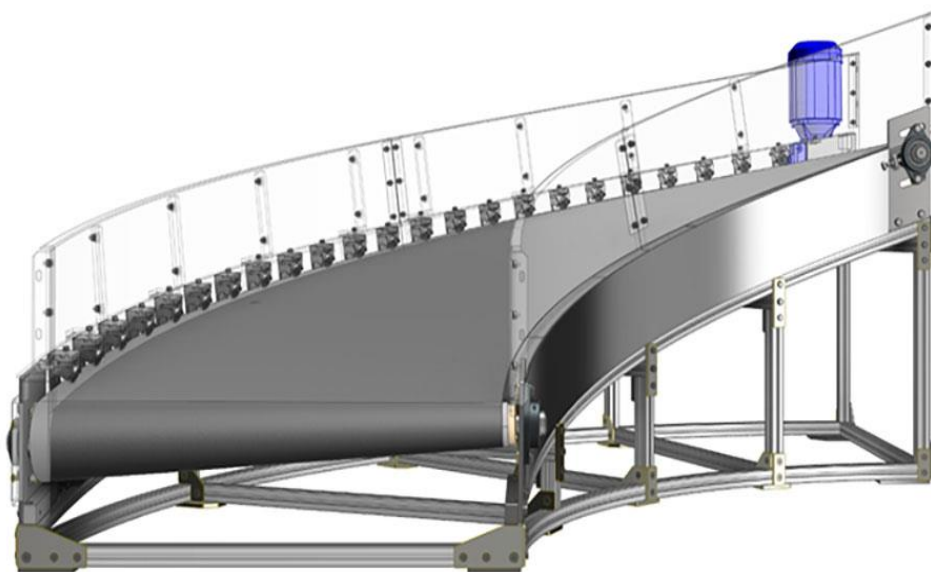

KC-130 Rapid Release Powered Belt Curve Conveyor

Technical Sales Brochure

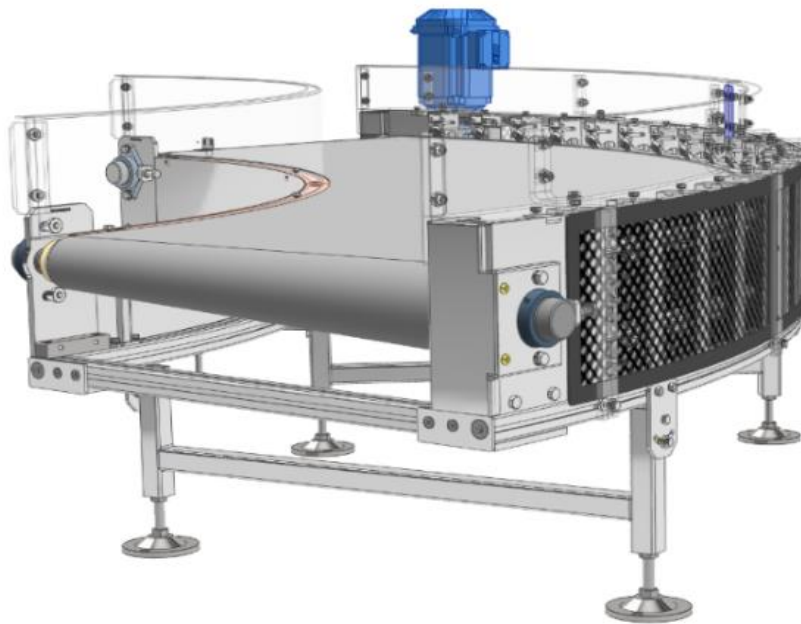



Introduction

Based at Plot 29, Jalan Teknologi 6, Taman Perindustrian Mengkibol, Kluang, Malaysia, Kairos Conveyor Sdn Bhd was established in 2014 with a specific purpose to design and fabricate quality conveyor modules, parts and spares for established integrators and end users within the material handling industry.

Utilizing many years of global experience in the manufacture, installation and maintenance of powered belt curves, the KC-130 rapid release powered belt curve conveyor has been collectively designed into what we perceive to be the optimum curve in terms of perfect geometry, material selection, cost of manufacturing, ease of assembly, rapid part exchange, and full accessibility for maintenance purposes.

Since moving to our new facility in July 2017, our infrastructure in terms of skilled resource, in-house manufacturing capability, quality assurance and capacity to meet market demand has steadily increased.

Spare belts and pulleys, considered the most critical components of a curve conveyor, have been repeatedly supplied to the market since 2015, which has helped to assure valued customers in our material selection and manufacturing processes prior to the release of the KC-130 curve to the global market.

Subsequent to our initial R&D and extensive testing, we have been confidently supplying the Kairos Curve KC-130 to major integrators and international brand end users since the beginning of 2017

Our unique design, featuring a frame consisting of vertical pillars and the rapid release guidance system which genuinely ensures a very short down time during belt, pulley and bearing replacement. It also facilitates economic fabrication of spiral curves.

Our vision is to become a preferred supplier of conveyor modules, parts, & reasonably priced spares to the major global integrators who provide turnkey services to the baggage handling, freight / parcel handling & the distribution market, through a partnership borne of respect and understanding, excellence in quality, reliable / fair customer service and timely delivery.



The purpose of this Technical Sales Manual is to highlight the design and benefits of the KC-130 powered belt flat & spiral curves

We also show detailed information regarding the design criteria required in curve selection

Please use this information when considering Kairos as a partner for your projects and when requesting a proposal.

Table of Contents

1.0	Part Description	4
2.0	Rapid Release Belt Guidance System	4
3.0	Pulley Design	5
4.0	Frame & Deckplate Design	5 ~ 6
5.0	Abbreviations	7
6.0	Limitations	8
7.0	Warranty	8
8.0	After Sales Service	9
9.0	Contact	9



1.0 Part Description

The KC-130 rapid release powered belt curve conveyor has been designed with the user in mind.

Using our many years of collective experience in the manufacture, installation and maintenance of powered curve conveyors, particular attention has been paid to ensure full accessibility to all areas of the unit, and a quick, simple change of parts, regardless of the location within a system.

2.0 Our Rapid Release Belt Guidance System

The guidance principle is a PU bead, sewn around a precision cut, endless, conical belt that is smoothly guided through multiple angled precision bearings around the outer edge of the curve. This proven design ensures that an even load is taken on all bearings around the outer edge, ensuring a long-life cycle with minimum wear.

Understanding that minimum downtime is essential when there is the occasional need to change an endless belt, we have designed our bearing holder assembly to be accessible from the outer radius once the outer trim is removed, to be rapidly opened by hand to release the beading from between the retaining bearings.

In operation, a force is applied to the bearings, due to a lateral pull on the belting towards the inner radius. The holder is designed to transfer this force by trapping an affixed PU beading between the 2 angled bearings located in reinforced nylon holders. This proven beading design ensures the bearing sets create an angled force, locking the beading to the belt at the points of bearing to beading contact. This ensures zero load on the stitching

The holder can be opened without tools by un-clipping a pair of flagged location tabs inwards and forwards to release the bearing holder from locked position indents located in the single spine pillar.

A further pressing or of the thumb outdents vertically pushes the bearing holder from a locked position to a released position. Both positions are retained through the implementation of a spring clip located between the bearing holder and the pillar.

The holder is held in place by retaining pins through the single spined pillar to prevent the holder from becoming detached from the pillar and being misplaced during the belt change operation.

Once the new belt is installed, the holders can be clicked back into position once the beading is pulled back into place and the locking flag pins rotated outwards to secure.

The belt can then be re-tensioned at the housings

The entire pillar can easily be removed by simply loosening 2 bolts which are retained in the frame, and one bolt connecting to the ring within 40 secs, and worked upon whilst the unit is set to run again. This can be repeated to ensure a complete bearing change with minimum downtime when required.

3.0 Pulley Design

This guidance system requires the friction drive principle, in which a PVC lagged tapered drive roller is provided ensuring a positive drive across the whole width of the belt

The drive and tail pulleys consist of carbon steel shafts machined to fit through the 'Y' bearings, to allow for hollow shaft mounting of the gearbox as standard. Each shaft is QC checked for tolerances in both diameter and run out before being assembled.

The core of both the drive and tail pulley is a molded, hardened PU foam material which is extremely durable and lightweight.

The drive pulley is lagged with a PVC grip surface to create the drive required across the whole width of the belt.

The tail pulley is an idler pulley, and therefore is covered with a smooth top lagging across the surface.

Drive shaft diameters are 30mm as standard, which caters for loads up to 100kg/m.

Larger diameter shafts can be installed if requested. The larger the drive shaft diameter, the less tensioning / adjustment available. Please consult with Kairos if larger diameter shafts are required / specified.

Both principles of PU beading through bearings and friction drive roller combined, allow for a positive drive, very high speeds, and extremely quiet operation (below 65db).

4.0 Frame & Deckplate Design

The base frame is constructed using an extruded aluminum 40mm x 40mm profile which is slotted on all 4 sides to accommodate "d" nuts along its length.

The slot and "d" nut system in this profile is used for multiple connection points for bearing housings, holder columns, sideguard supports, torque arm connection, underguards, leg sets and other accessories

The profile is rolled to the required arc on both the inner and outer radius's and cut to the correct angle / degree

Each corner is connected with both a 10mm thick gusset plate under the frame, and a 5mm thick upper connecting plate to connect the center of the roller profile to the end cross members.

Each cross member is connected via a 10mm thick gusset plate at each end

The frame is intentionally designed without any welding, to be easily assembled / installed / exchanged in very tight areas when required, to prevent unnecessary system downtime.

The bearing pillars are an integral part of the frame structure itself. They act as a supporting connection between the lower frame and upper ring. The distance between the pillars is calculated to enable the operator to access between the belts on the outer radius to enable cleaning / maintenance tasks, or dismantling / re-assembly of spare belts, pulleys or bearings without hindrance.

The upper ring is laser cut mild steel and designed to give structural strength to the lower frame when connected via the bearing pillars.

Inner and outer bearing housings are connected to the frame via steel blocks to enable easy removal from any position. They can easily be removed by removing 3 bolts (2 at the block, and one connecting to the ring)

The position of all 4 pulleys mounting flange bearings located in the housings are fully adjustable via a lockable tensioning bolt to allow for accurate tensioning.

The outer deckplate support brackets can be inserted and bolted into any holder pillar as required, as each pillar is moulded to accommodate the support bracket between the upper and lower sets of bearing holders. The quantity and spacing of deckplate supports is dependent on load requirements

To assist with minimum belt change time, we have designed extended outer deckplate support brackets from these pillars to enable the deckplate to cantilever from the outer radius. This ensures that the deckplate never has to be removed. Only the inner sideguard, trim and housings must be removed to enable the belt to slide out of the inner radius with the deckplate remaining in place

The inner trim is quickly removable by unscrewing locating screws

The Outer trim sections are fabricated from transparent mesh frames, to enable maintenance to inspect the condition of the beading or pulleys as required. These are easily removed to release the holders when changing a belt.

Inner sideguard is bolted directly to the deckplate using inserts, and can be installed and released without the need to remove and supplied guarding

The outer sideguard(s) are mounted using brackets connected to the aluminum frame and upper ring. The support brackets are slotted @ 30mm which are set to the correct height from belt in the down position. Once the connecting guards are released, and the nuts connecting the sideguard studs to the brackets are loosened, the sideguard can be pulled to the top of the slots, creating enough gap for the beading to pass and therefore eliminating the need to remove the whole outer sideguard when changing a belt.

Standard overhang for the sideguards from the end of frame can vary between 15mm ~ 25mm. An overhang of the sideguards is recommended to allow for adjustment / tensioning of the drive and tail rollers without impediment from the adjoining conveyors.

The diameter of the shaft is an important factor in the recommended overhang. For example, if a 40mm diameter shaft is required at the inner radius, the large flange bearing required to accommodate the shaft will perhaps overhang the frame on the inner radius once tensioned.

The outer radius protective guards are connected to the bearing flanges themselves. This ensures that the guard moves with the bearing and pulley to the correct tensioning position, and does not move independently, which could potentially trap / cut the belt when tensioning.

Kairos use a combi-board slider bed as standard on our flat curves and steel plate over sub-frame on out spirals. This slider bed is well proven in the industry, highly durable, considerably lighter than steel, and can withstand high load and high impact without losing original shape. It also acts as a damper, preventing reverberation, which in turn ensures extremely low sound levels.

5.0 Abbreviations

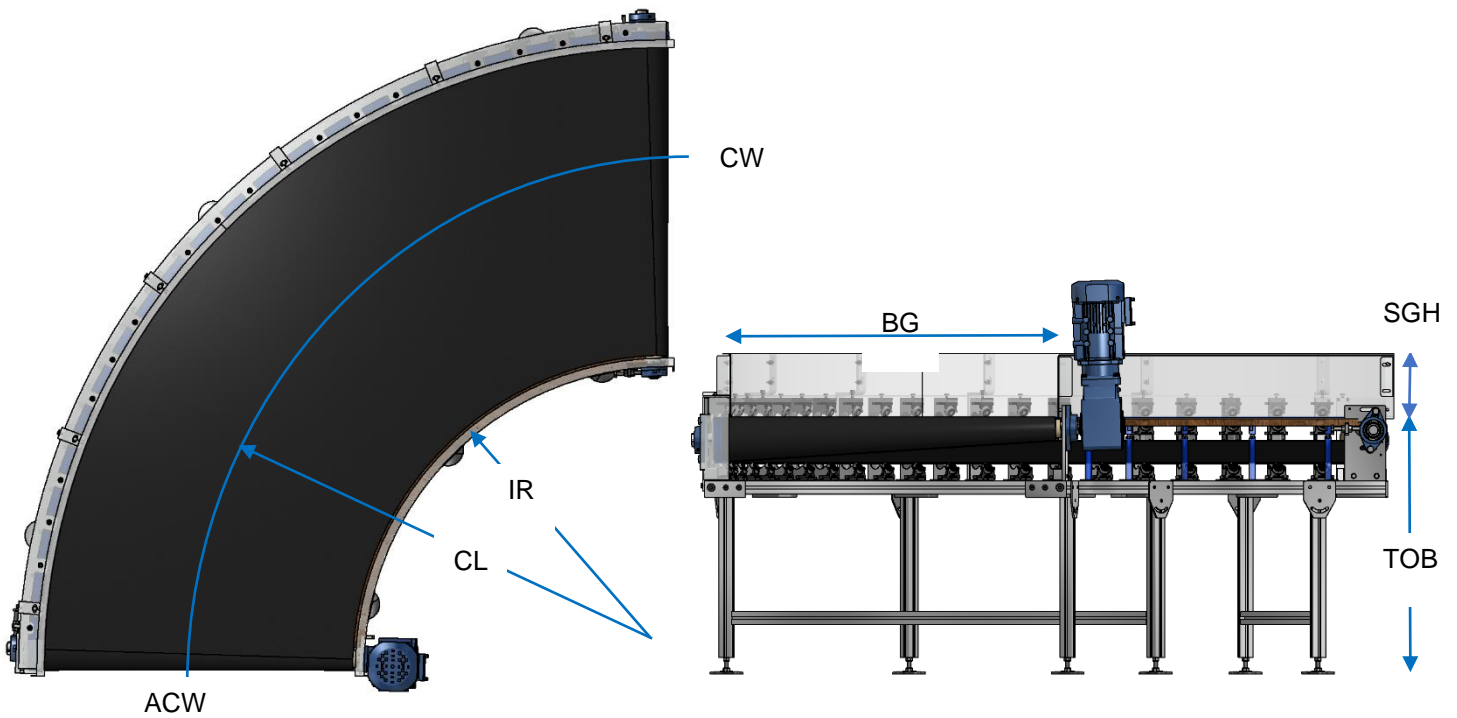

Description	KC-130 Rapid Release Powered Belt Curve Conveyor	
Model variations	KC-130 Shaft Driven (Clockwise / Anti-Clockwise, Inside / Outside Drive)	
	KC-130 Chain Driven (Clockwise / Anti-Clockwise, Inside / Outside)	
	KC-130 Timing Belt (Clockwise / Anti-Clockwise, Inside / Outside Drive)	
Inner Radius (IR)	To be advised upon RFQ	500mm ~ 4000mm
Centerline Radius (CL)	To be advised upon RFQ	750mm ~ 4750mm
Width Between Guards (BG)	To be advised upon RFQ	500mm ~ 1500mm
Nominal angle (Degree)	To be advised upon RFQ	15° ~ 180° (Limitations on larger sizes)
Direction (CW) or (ACW)	To be advised upon RFQ	Clockwise or Anti-Clockwise
Side Guard Height (SGH)	To be advised upon RFQ	100mm ~ 600mm (Standard)
Conveyor height (TOB)	To be advised upon RFQ	Min. 300 mm using shaft mounted motor. Min. 600mm using chain or timing belt drive.
Conveyor belt type	To be advised upon RFQ	Flame retardant, 2 ply
Dimensions of goods	To be advised upon RFQ	
Load of conveyed goods	To be advised upon RFQ	max. 75 kg/m (depending on speed)
Conveyor speed	To be advised when ordering	up to 3.0 m/sec.
Height Difference (Spirals)	To be determined upon RFQ	Limited to IR / BG & Degree due to the acute angles created at the inner radius

6.0 Limitations

There are limitations on the ratio of the inner radius and belt width, due to the diameter of the tapered pulley at the inner bearing.

Generally, the wider the belt width, the larger the inner radius requirement.

Below is a basic table to indicate permissible belt widths in comparison to inner radius

Limitations apply to angle of curve when inner radius and between guard width exceeds 3m. Please check with Kairos on possible configurations.

		Between Guard Width												
		500	600	700	800	900	1,000	1,100	1,200	1,300	1,400	1,500		
Inner Radius	200	x	x	x	x	x	x	x	x	x	x	x	x	x
	300	✓	x	x	x	x	x	x	x	x	x	x	x	x
	400	✓	✓	✓	x	x	x	x	x	x	x	x	x	x
	500	✓	✓	✓	✓	x	x	x	x	x	x	x	x	x
	600	✓	✓	✓	✓	✓	x	x	x	x	x	x	x	x
	700	✓	✓	✓	✓	✓	✓	x	x	x	x	x	x	x
	800	✓	✓	✓	✓	✓	✓	✓	x	x	x	x	x	x
	900	✓	✓	✓	✓	✓	✓	✓	✓	✓	x	x	x	x
	1,000	✓	✓	✓	✓	✓	✓	✓	✓	✓	✓	✓	✓	✓
	1,100	✓	✓	✓	✓	✓	✓	✓	✓	✓	✓	✓	✓	✓
	1,200	✓	✓	✓	✓	✓	✓	✓	✓	✓	✓	✓	✓	✓
	1,300	✓	✓	✓	✓	✓	✓	✓	✓	✓	✓	✓	✓	✓
	1,400	✓	✓	✓	✓	✓	✓	✓	✓	✓	✓	✓	✓	✓
	1,500	✓	✓	✓	✓	✓	✓	✓	✓	✓	✓	✓	✓	✓
	> 1,500	✓	✓	✓	✓	✓	✓	✓	✓	✓	✓	✓	✓	✓
< 4,000	✓	✓	✓	✓	✓	✓	✓	✓	✓	✓	✓	✓	✓	

***Limitations in angle apply to larger curves for shipping purposes. Please check possibilities with Kairos.**

7.0 Warranty

As a component supplier, Kairos are generally not in control of delivery to site, installation, commissioning and beginning of any DLP period agreed between the integrator and the end user.

As a means to control and record the commencement of the warranty period, Kairos machinery is warranted for a period of 24 months from date of handover to the end user, or 30 months from the date of dispatch from our factory, and submittal of our associated tax invoice as standard, whichever is soonest

Extension to this warranty to suit back-to-back agreements can be discussed and commercial terms agreed.



8.0 After Sales Service

We have established after-sales support through reliable support partners in key geographic regions.

All technical support / questions regarding our product can be directed to our dedicated service mail address, where our engineers will be available to respond as soon as possible.

Level 1 – Direct contact with our local support team. They will be able to discuss the issue, and attend the site if it's deemed necessary.

Level 2 – If the issue cannot be resolved at level 1, the situation will be escalated to Kairos engineering in Malaysia for discussion / support.

Level 3 – Kairos will fabricate new parts and send them to the site, and if required provide a technician to support either the on-site maintenance team or the local support partner, on the replacement of the parts / resolution of the issue.

Please specify your project order number, and the specifications of the unit when contacting customer support. If spare parts are required, please identify them through section 6.0 Component / Spares Overview in our O&M manual sent with the units

9.0 Contact

Thank you for your interest in our product.

Please contact a sales representative through any of the below channels

Sales :- sales@kairosconveyor.com
Customer Support :- service@kairosconveyor.com
Asia Pacific :- +60 13 7200 426
Europe :- +44 7836 291 575

Website :- www.kairosconveyor.com

Kairos Global Sdn Bhd
29, Jalan Teknologi 6
Kawasan Perindustrian Mengkibol
Kluang 86000
Johor, Malaysia
Telephone:- +60 7 776 7196