

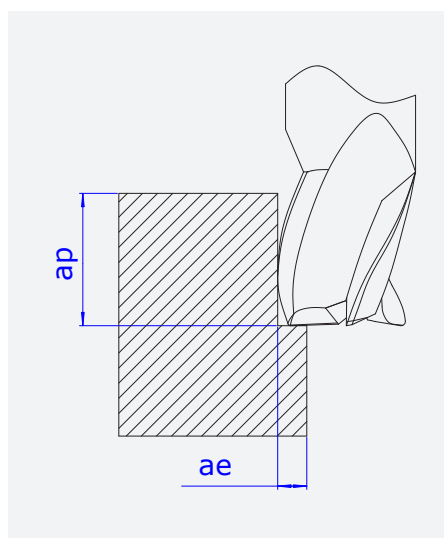

## Skärdata för MBTA96

Materialgrupp		Material nr	Brottgräns N/mm	Svensk Standard	Skärhastighet Vc
Aluminiumlegering	<5%Si	4,1		4007,4125,4212	300-1500
	<10% Si	4,2		4244,4245,4247,4250,4252	250-800
	>10% Si	4,3		4253,4261,4247,4260	150-500
Koppar	Koppar	5,1		5010,5011,5030	120-300
Kopparlegering	Bronze/Brass	5,7		5112,5122,5150,5165,5168, 5428	150-600
Plaster	Thermoplaster	8,1			350-1000
	Duroplaster	8,2			200-500
	Fibrous-förstärkta plaster	8,3			160-600
	Hårt gummi	8,4			160-600
	Polyamide	8,5			200-600

## Matning fz



Dia.		$ap=4xD$ $ae=0,1-0,15xD$
8		0,036-0,048
10		0,045-0,06
12		0,054-0,073
16		0,072-0,097
20		0,09-0,121