

# Menuet

**Une manière d'apprendre le style classique**

# La danse



MENUET D'AUDET,  
Figuré par M. MAONY.

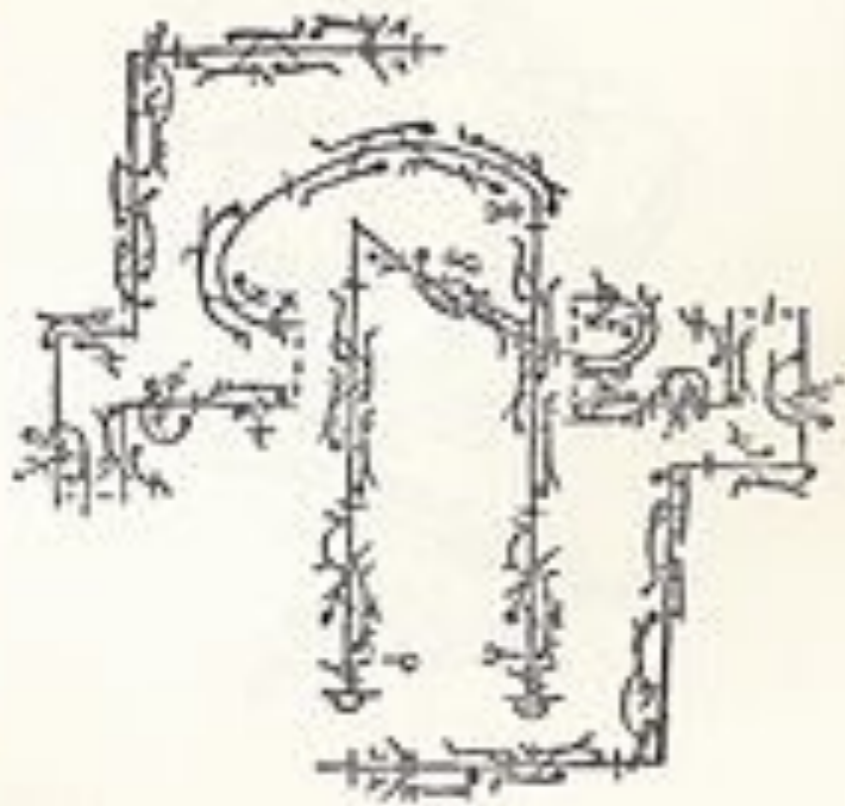

**PAS DE MENUET**

A 1 mouvement.      à 2 mouvements      à 3 mouvement.  
 normal à la bohémienne



# MOZART

1756 - 1791

I. Notenbuch

für Maria Anna (Nannerl) Mozart

1759

**Léopold Mozart, Joseph Richard Estlinger et d'autres ...**

**Sans doute + de 60 morceaux !**

## 2. Menuett in F

Menuet

2.

tr

This system contains the first eight measures of the minuet. The treble clef staff features a melody of eighth and quarter notes, with a trill (tr) over the final note. The bass clef staff provides a harmonic accompaniment with chords and rests. The key signature has one flat (B-flat) and the time signature is 3/4. The system concludes with a repeat sign.

9

tr

This system contains the final eight measures of the minuet, starting at measure 9. The treble clef staff continues the melodic line with eighth notes and quarter notes, ending with a trill (tr). The bass clef staff continues the accompaniment with chords and rests. The system concludes with a repeat sign.

# Forme

# Structure

« **Modèle** »

**Menuet de 16 mesures**

# 2. Menuett in F

## Partie 1

Menuet

Musical score for the first part of the Minuet in F, measures 1 through 8. The score is written for piano in F major and 3/4 time. The right hand (treble clef) plays a melody of eighth and quarter notes, while the left hand (bass clef) provides a harmonic accompaniment of chords and eighth notes. A red rectangular box highlights the entire passage from measure 1 to measure 8. The final two measures (7 and 8) are also highlighted with a light blue rounded rectangle and feature a trill (tr) over the final note of the melody.

## Partie 2

9

Musical score for the second part of the Minuet in F, measures 9 through 16. The score continues from the first part. The right hand (treble clef) features a more active melody with eighth-note patterns, while the left hand (bass clef) continues with a steady accompaniment. A blue rectangular box highlights the entire passage from measure 9 to measure 16. The final two measures (15 and 16) are also highlighted with a light blue rounded rectangle and feature a trill (tr) over the final note of the melody.



## 2. Menuett in F

Menuet

The first system of the musical score for '2. Menuett in F' is shown. It consists of two staves: a treble clef staff and a bass clef staff. The key signature is one flat (F major) and the time signature is 3/4. The first five measures are enclosed in a red rectangular box, and the last five measures are enclosed in a blue rectangular box. The blue box contains a trill (tr) over the final note of the first staff.

The second system of the musical score for '2. Menuett in F' is shown. It consists of two staves: a treble clef staff and a bass clef staff. The key signature is one flat (F major) and the time signature is 3/4. The first five measures are enclosed in a green rectangular box, and the last five measures are enclosed in a blue rectangular box. The blue box contains a trill (tr) over the final note of the first staff. The number '9' is written above the first measure of the first staff.

Contraste



# Unité mélodique et harmonique

# MOTIF! (idée)

## 2. Menuett in F

Menuet

2.

a1 a2 a1 b

tr

Detailed description: This system of music is in 3/4 time and F major. It consists of two staves. The first staff has a treble clef and the second a bass clef. The first three measures are grouped by a solid red border and labeled 'a1', 'a2', and 'a1' respectively. The first and third measures are also enclosed in dashed red borders. The fourth measure is enclosed in a solid blue border and labeled 'b'. A trill (tr) is marked above the first note of the fourth measure. The bass line consists of chords in the first three measures and a single note in the fourth.

9

c

tr

Detailed description: This system of music starts at measure 9. It consists of two staves. The first staff has a treble clef and the second a bass clef. The first two measures are grouped by a solid green border and labeled 'c'. The third measure is enclosed in a solid red border. The fourth measure is enclosed in a solid blue border and labeled 'b'. A trill (tr) is marked above the first note of the fourth measure. The bass line consists of chords in the first two measures and a single note in the third and fourth measures.

# 2. Menuett in F

Menuet

The first system of the musical score consists of two staves. The upper staff is in treble clef and the lower staff is in bass clef. The key signature has one flat (B-flat) and the time signature is 3/4. The music is marked with a '2.' indicating a second ending. The first three measures of the upper staff are circled in red, and the last two measures are circled in blue. A trill (tr) is indicated above the final note of the blue circle.

The second system of the musical score consists of two staves. The upper staff is in treble clef and the lower staff is in bass clef. The key signature has one flat (B-flat) and the time signature is 3/4. The music is marked with a '9' at the beginning of the upper staff. The first four measures of the upper staff are circled in red, and the last two measures are circled in blue. A trill (tr) is indicated above the final note of the blue circle. A cyan rectangle highlights the first four notes of the upper staff.

# 2. Menuett in F

Menuet

I

IV

I

II

V

I

tr

The first system of the musical score for '2. Menuett in F' is shown. It consists of two staves: a treble clef staff and a bass clef staff. The key signature is one flat (F major) and the time signature is 3/4. The music is marked with a '2.' in the left margin. Above the treble staff, Roman numerals are placed above specific measures: a red 'I' above the first measure, a red 'IV' above the fourth measure, a red 'I' above the seventh measure, a green 'II' above the eighth measure, a green 'V' above the ninth measure, and a green 'I' above the tenth measure. A trill symbol 'tr' is placed above the final note of the tenth measure. The bass staff contains a simple accompaniment of chords and rests.

Tension

V



I

II

V

I

tr

The second system of the musical score for '2. Menuett in F' is shown. It consists of two staves: a treble clef staff and a bass clef staff. The key signature is one flat (F major) and the time signature is 3/4. The music is marked with a '9' in the left margin. Above the treble staff, Roman numerals are placed above specific measures: a red 'V' above the first measure, a red 'I' above the fifth measure, a green 'II' above the eighth measure, a green 'V' above the ninth measure, and a green 'I' above the tenth measure. A trill symbol 'tr' is placed above the final note of the tenth measure. The bass staff contains a simple accompaniment of chords and rests.

# 3. Menuett in C

3.

Musical notation for measures 1-5. The piece is in 3/4 time and C major. Measure 1 starts with a treble clef, a key signature of one sharp (F#), and a 3/4 time signature. A bracketed treble clef symbol [A] is above the first note. The melody in the treble clef consists of quarter notes: C4, D4, E4, F#4, G4, A4, B4, C5. The bass clef accompaniment consists of quarter notes: C3, F2, C3, F2, C3, F2, C3, F2. Measures 2-5 continue the melody and accompaniment with various rhythmic patterns and phrasing.

6

Musical notation for measures 6-11. Measure 6 continues the melody and accompaniment. Measure 7 features a slur over the melody. Measure 8 has a repeat sign. Measure 9 has a bracketed treble clef symbol [A] above the first note. Measures 10-11 continue the melody and accompaniment.

12

Musical notation for measures 12-15. Measure 12 continues the melody and accompaniment. Measure 13 has a bracketed treble clef symbol [A] above the first note. Measure 14 has a slur over the melody. Measure 15 ends with a repeat sign and a fermata over the final note.

# 3. Menuett in C

## Partie 1

The first system of the musical score, measures 1-4, is enclosed in a red border. It features a treble clef with a 3/4 time signature and a key signature of one sharp (F#). The melody in the treble clef starts with a quarter rest, followed by a quarter note G4, and continues with eighth and quarter notes. The bass clef provides a simple accompaniment of quarter notes. A first ending bracket is shown above the first measure of the treble staff.

## Partie 2

The second system of the musical score, measures 5-8, is enclosed in a blue border. It continues the melody and accompaniment from the first system. A blue highlight covers measures 6 and 7, which contain a melodic phrase in the treble clef and its accompaniment in the bass clef. A first ending bracket is shown above the first measure of the treble staff.

The third system of the musical score, measures 9-12, is enclosed in a blue border. It concludes the piece. A blue highlight covers measures 11 and 12, which contain the final melodic phrase in the treble clef and its accompaniment in the bass clef. A first ending bracket is shown above the first measure of the treble staff. Measure 12 ends with a double bar line and a repeat sign.



# 3. Menuett in C

3.

Musical notation for measures 1-5. The first four measures are enclosed in a red box, and the fifth measure is enclosed in a blue box. The notation includes a treble clef, a 3/4 time signature, and a key signature of one sharp (F#). A first fingering [1] is indicated above the first measure.

6

Musical notation for measures 6-10. Measures 6-9 are enclosed in a blue box, and measure 10 is enclosed in a green box. The notation includes a treble clef, a 3/4 time signature, and a key signature of one sharp (F#). A first fingering [1] is indicated above the first measure of the green box.

12

Musical notation for measures 11-15. Measure 11 is enclosed in a green box, and measures 12-15 are enclosed in a blue dashed box. The notation includes a treble clef, a 3/4 time signature, and a key signature of one sharp (F#). A first fingering [1] is indicated above the first measure of the blue dashed box, and an asterisk (\*) is placed above the eighth measure.

8 mesures

8 mesures

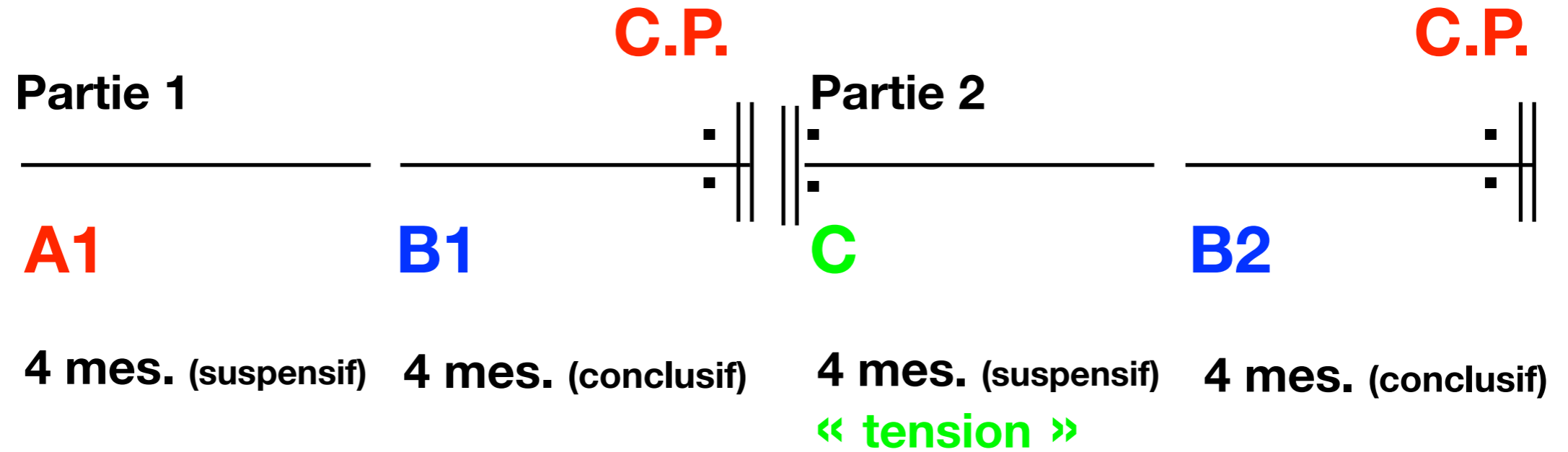

**Carrure !**

# Unité mélodique et harmonie

# 3. Menuett in C

3.

Musical notation for measures 1-4. The first staff is treble clef, the second is bass clef. Measures 1-2 are enclosed in a solid red box, measures 3-4 in a dashed red box, and measures 5-6 in a solid blue box. A bracket on the left groups the first two staves. A measure rest symbol is above the first measure.

6

Musical notation for measures 5-8. Measures 5-6 are enclosed in a solid blue box, measures 7-8 in a solid cyan box, measures 9-10 in a solid green box, and measures 11-12 in a solid green box. A bracket on the left groups the first two staves. A measure rest symbol is above the first measure.

12

Musical notation for measures 9-12. Measures 9-10 are enclosed in a solid green box, measures 11-12 in a dashed blue box, and measures 13-14 in a dashed cyan box. A bracket on the left groups the first two staves. A measure rest symbol is above the first measure.

System 1: Treble and Bass clefs, 3/4 time signature. The treble staff contains a melodic line with eighth and sixteenth notes, including a sharp sign. The bass staff contains a bass line with quarter and eighth notes.

System 2: Treble and Bass clefs, 3/4 time signature. The treble staff contains a melodic line with dotted half notes and eighth notes. The bass staff contains a bass line with quarter and eighth notes. This system is highlighted with a red border.

System 3: Treble and Bass clefs, 3/4 time signature. The treble staff contains a melodic line with eighth and sixteenth notes, including a sharp sign. The bass staff contains a bass line with quarter and eighth notes.

System 4: Treble and Bass clefs, 3/4 time signature. The treble staff contains a melodic line with eighth and sixteenth notes, including a sharp sign. The bass staff contains a bass line with quarter and eighth notes. This system is highlighted with a red border.

# 3. Menuett in C

3.

I (M) I II V idem I (M) I

6

II V I IV V I I IID V I V IID

12

V I I IV V I (M) I IV II V I

Menuet

Diesen Menuet hat d. Wolfangerl auch im vierten jahr seines alters gelernet.

19.

Musical notation for measures 19-24. The first staff has a treble clef and the second a bass clef. Measure 19 starts with a square box containing a quarter note G4. The piece concludes with a repeat sign and a fermata over the final note.

6

Musical notation for measures 6-11. The first staff has a treble clef and the second a bass clef. Measure 6 starts with a square box containing a quarter note G4. The piece concludes with a repeat sign and a fermata over the final note.

11

Musical notation for measures 11-16. The first staff has a treble clef and the second a bass clef. Measure 11 starts with a square box containing a quarter note G4. The piece concludes with a repeat sign and a fermata over the final note.

# Partie 1

Menuet

Diesen Menuet hat d. Wolfangerl auch im vierten jahr seines alters gelernet.

Musical score for Part 1, measures 1-10. The score is in 3/4 time and B-flat major. The first five measures are enclosed in a red box, and the last five measures are enclosed in a blue box. A bracket on the left side of the first five measures is labeled '19.'. A square box above the first measure of the red section contains a note with a stem and a flag.

# Partie 2

Musical score for Part 2, measures 6-10. The score is in 3/4 time and B-flat major. The first five measures are enclosed in a blue box, and the last five measures are enclosed in a green box. A bracket on the left side of the first five measures is labeled '6'.

Musical score for Part 2, measures 11-15. The score is in 3/4 time and B-flat major. The first five measures are enclosed in a green box, and the last five measures are enclosed in a blue box. A bracket on the left side of the first five measures is labeled '11'. Square boxes above the first measure of the green section and the first measure of the blue section contain notes with stems and flags.



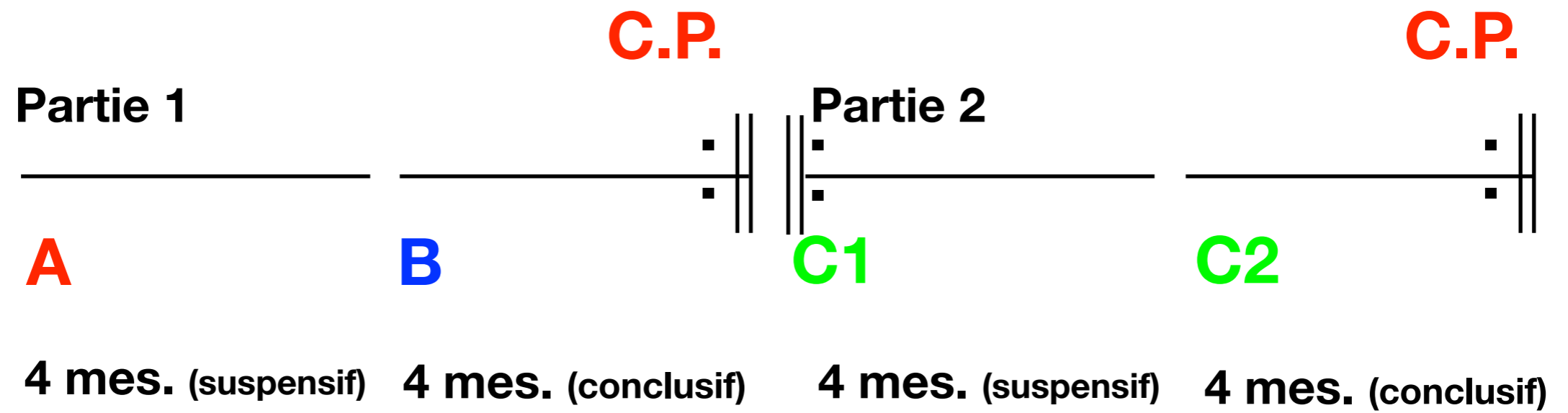

**Carrure !**

Menuet

Diesen Menuet hat d. Wolfangerl auch im vierten jahr seines alters gelernet.

19.

Musical score for the first system of a minuet, measures 1-5. The treble clef staff has a key signature of one flat and a 2/4 time signature. A red box highlights measures 1-3, a second red box highlights measures 4-5, and a blue box highlights measure 5. A blue horizontal line is drawn above the blue box. A square box above measure 1 contains a note symbol.

Musical score for the second system of a minuet, measures 6-10. The treble clef staff has a key signature of one flat. A blue box highlights measures 6-7, and a green box highlights measures 8-10. A blue horizontal line is drawn above the blue box.

Musical score for the third system of a minuet, measures 11-15. The treble clef staff has a key signature of one flat. Square boxes above measures 11, 13, and 15 contain note symbols.

# Partie 1

Musical score for Partie 1, measures 1-6. The score is written for piano in 3/4 time, featuring a treble and bass clef. The key signature has one flat (B-flat). The music consists of a simple melody in the treble clef and a bass line in the bass clef. A red border highlights the entire score. The number '6.' is written in the left margin.

# Partie 2

Musical score for Partie 2, measures 6-11. The score is written for piano in 3/4 time, featuring a treble and bass clef. The key signature has one flat (B-flat). The music consists of a simple melody in the treble clef and a bass line in the bass clef. A red border highlights the entire score. The number '6' is written in the left margin. A section of the score, measures 7-10, is highlighted with an orange background.

Musical score for Partie 2, measures 11-15. The score is written for piano in 3/4 time, featuring a treble and bass clef. The key signature has one flat (B-flat). The music consists of a simple melody in the treble clef and a bass line in the bass clef. A blue border highlights the entire score. The number '12' is written in the left margin. A section of the score, measures 13-15, is highlighted with a light blue background. A triplet of notes is marked with a '3' in the treble clef.

# Partie 1

Musical score for Partie 1, measures 1-6. The score is in 2/4 time with a key signature of one flat. The first staff is circled in cyan, and the entire system is enclosed in a red border.

# Partie 2

Musical score for Partie 2, measures 7-11. The score is in 2/4 time with a key signature of one flat. The first staff is circled in cyan, and the entire system is enclosed in a blue border.

# #1

Musical score for Partie 2, measures 12-15. The score is in 2/4 time with a key signature of one flat. The first staff is circled in cyan, and the entire system is enclosed in a green border.

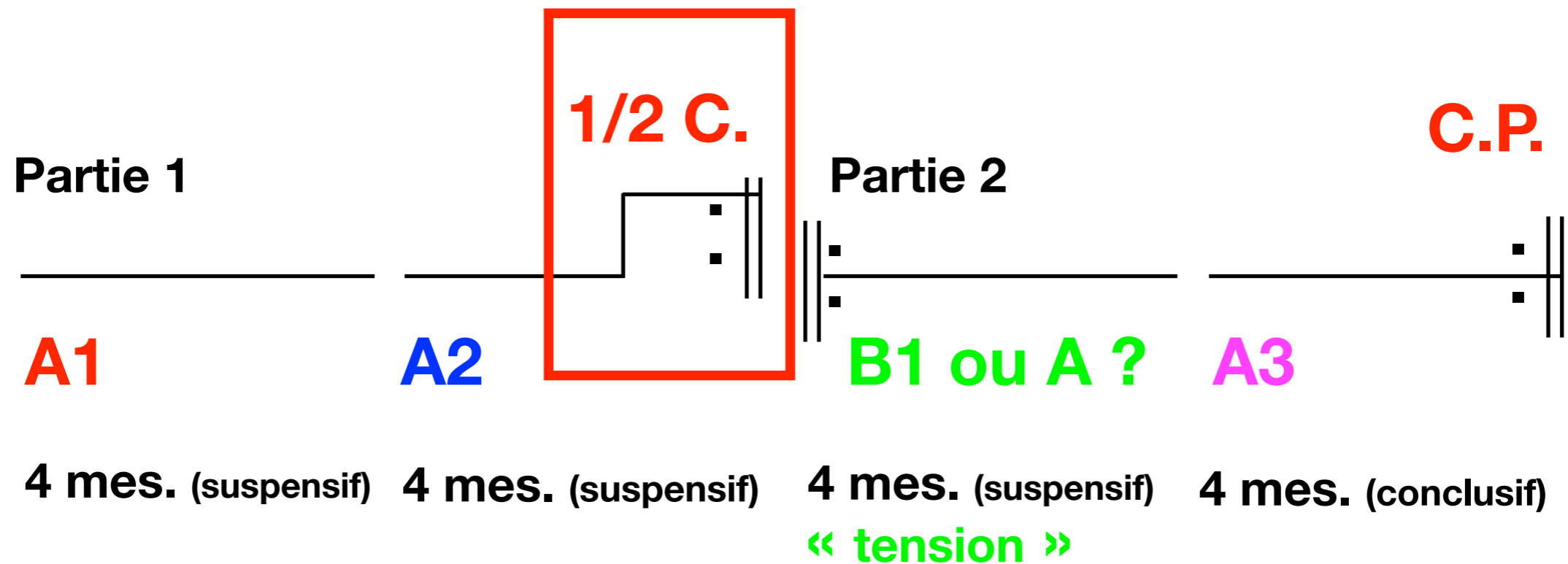
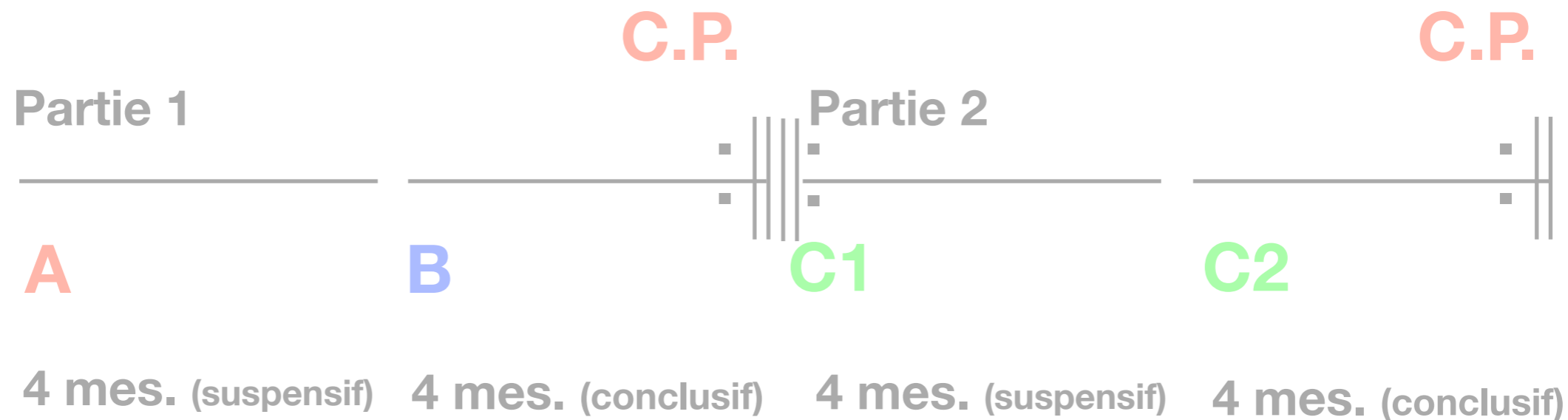

17.

Musical score for measures 17-19. Measure 17 is highlighted with a red border. Measure 18 has a cyan box around the first two notes. Measure 19 is highlighted with a blue border.

6

tr

Musical score for measures 6-8. Measure 7 is highlighted with an orange background and contains a trill (tr). Measure 8 is highlighted with a green border.

11

tr

Musical score for measures 11-13. Measure 13 is highlighted with a blue background and contains a trill (tr).

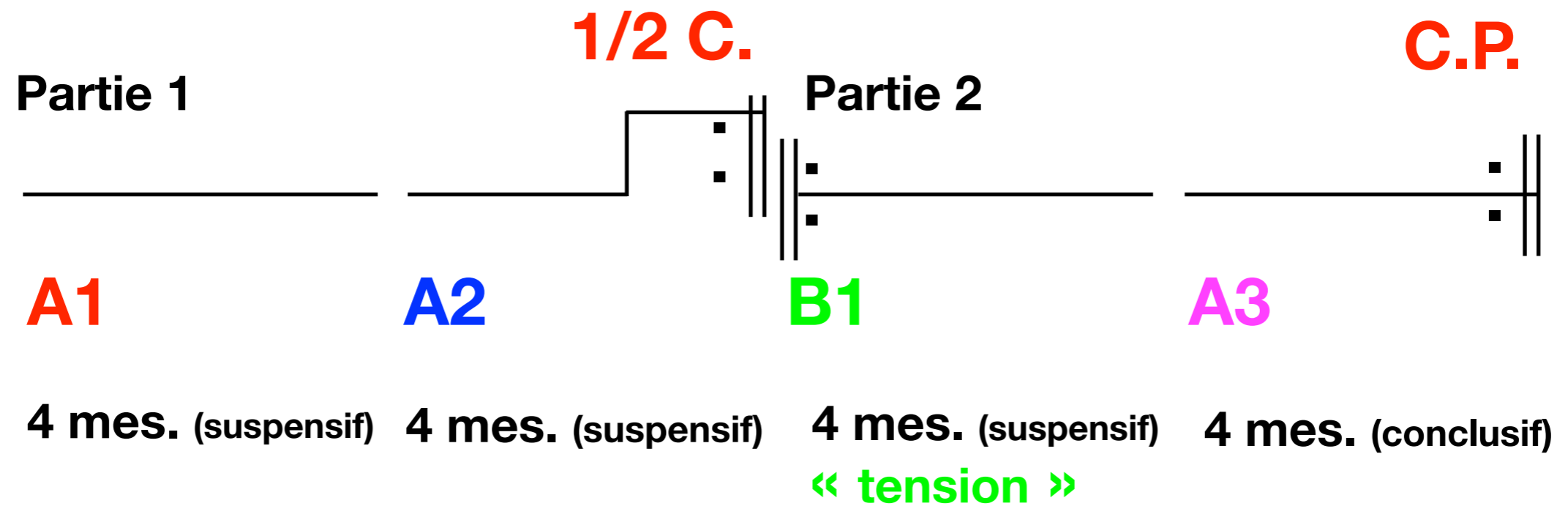
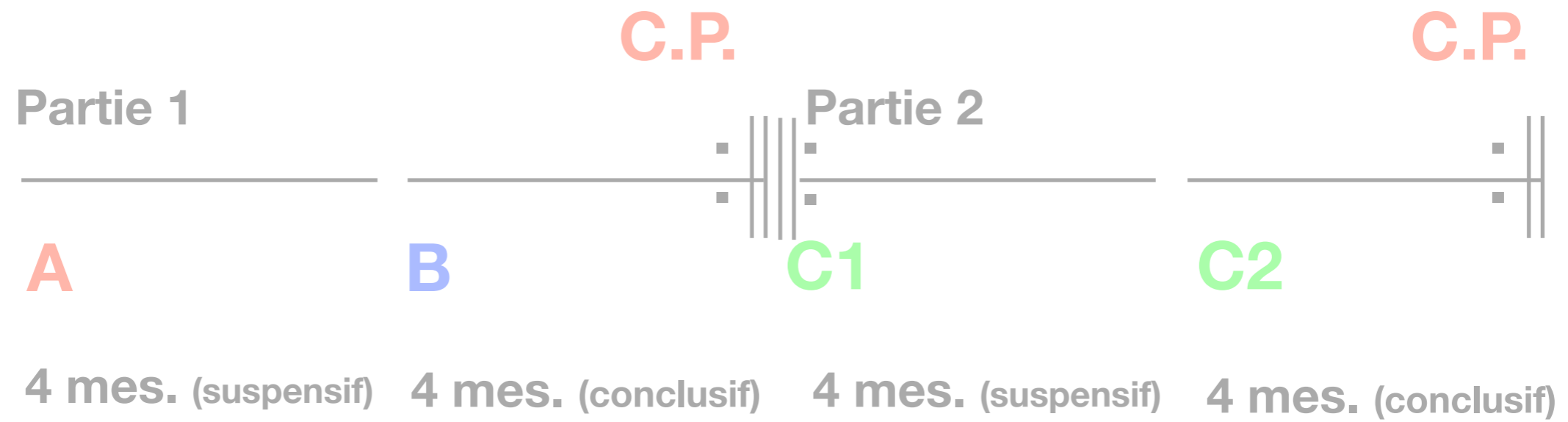

(Menuett)

KV 1e

5.

Musical notation for measures 5-6. The system consists of two staves: a treble clef staff and a bass clef staff. The key signature is one sharp (F#) and the time signature is 3/4. Measure 5: Treble clef has a quarter note G4 (finger 5), a quarter note A4 (finger 4), and a quarter note B4. Bass clef has a quarter rest, a quarter note G3, and a quarter note A3. Measure 6: Treble clef has a quarter note B4 (finger 2), a quarter note C5 (finger 2), and a quarter note B4. Bass clef has a quarter note G3 (finger 3), a quarter note A3 (finger 2), and a quarter note B3. Fingering numbers 3, 2, and 1 are written below the bass staff for measures 5, 6, and 6 respectively.

6

Musical notation for measures 7-10. The system consists of two staves: a treble clef staff and a bass clef staff. Measure 7: Treble clef has a quarter note G4 (finger 5), a quarter note A4 (finger 2), and a quarter note B4. Bass clef has a quarter note G3 (finger 1), a quarter note A3 (finger 2), and a quarter note B3. Measure 8: Treble clef has a quarter note C5 (finger 3), a quarter note B4, and a quarter note A4. Bass clef has a quarter note G3, a quarter note A3, and a quarter note B3. Measure 9: Treble clef has a quarter note G4 (finger 2), a quarter note A4, and a quarter note B4. Bass clef has a quarter note G3, a quarter note A3, and a quarter note B3. Measure 10: Treble clef has a quarter note C5 (finger 3), a quarter note B4, and a quarter note A4. Bass clef has a quarter note G3, a quarter note A3, and a quarter note B3. A trill (tr) is indicated above the G4 in measure 9. A repeat sign is present at the end of measure 9. Fingering numbers 1, 2, 3, 2, 3, 1, and 3 are written below the staves for measures 7-10.

11

Musical notation for measures 11-14. The system consists of two staves: a treble clef staff and a bass clef staff. Measure 11: Treble clef has a quarter note G4, a quarter note A4, and a quarter note B4. Bass clef has a quarter note G3, a quarter note A3, and a quarter note B3. Measure 12: Treble clef has a quarter note C5 (finger 5), a quarter note B4 (finger 2), and a quarter note A4. Bass clef has a quarter note G3, a quarter note A3, and a quarter note B3. Measure 13: Treble clef has a quarter note G4, a quarter note A4, and a quarter note B4. Bass clef has a quarter note G3, a quarter note A3, and a quarter note B3. Measure 14: Treble clef has a quarter note C5, a quarter note B4, and a quarter note A4. Bass clef has a quarter note G3, a quarter note A3, and a quarter note B3. Fingering numbers 1, 2, 4, 3, and 2 are written below the staves for measures 11-14.



(Menuett)

KV 1e

Partie 1

Musical score for the first system of the Minuet, measures 1-5. The score is in treble and bass clefs with a key signature of one sharp (F#) and a 3/4 time signature. The music features a simple melody in the treble clef and a bass line in the bass clef. Fingerings are indicated by numbers 1-5 above or below notes. A red box highlights the entire system.

Musical score for the second system of the Minuet, measures 6-10. The score continues from the first system. A blue box highlights measures 7-8, which contain a trill (tr) and a modulation. The word "MODULATION!" is written in large red letters over this section. The score includes fingerings and a trill symbol. A blue box labeled "Partie 2" is also visible on the right side of the system.

Musical score for the third system of the Minuet, measures 11-15. The score continues from the second system. A blue box highlights measures 14-15, which contain a trill and a modulation. The score includes fingerings and a trill symbol.

(Menuett)

KV 1e

5

Musical score for measures 1-4. The first two measures are enclosed in a red box, and the last two in a blue box. Fingerings are indicated by numbers 1-5 above or below notes.

Musical score for measures 5-8. Measure 5 is in a blue box, and measures 6-8 are in a green box. A trill is marked in measure 6. Two notes in measure 7 are circled in cyan.

11

Musical score for measures 9-12. Measures 9-10 are in a green box, and measures 11-12 are in a blue box. Two notes in measure 9 are circled in cyan.

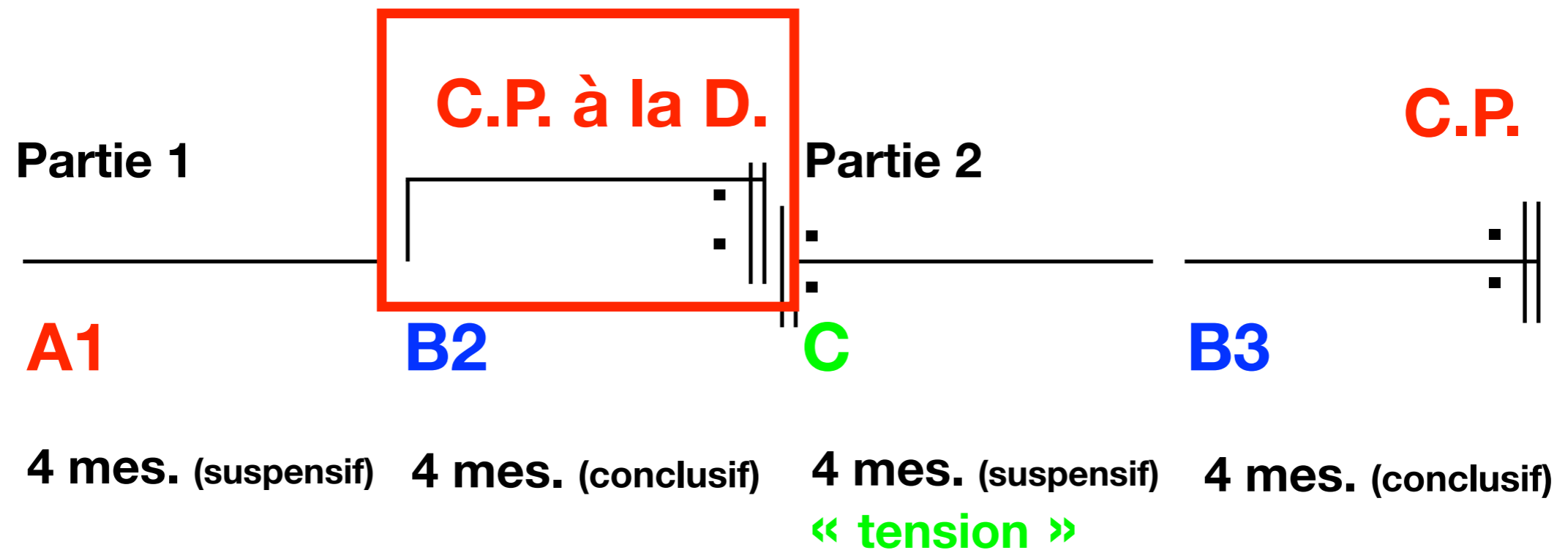
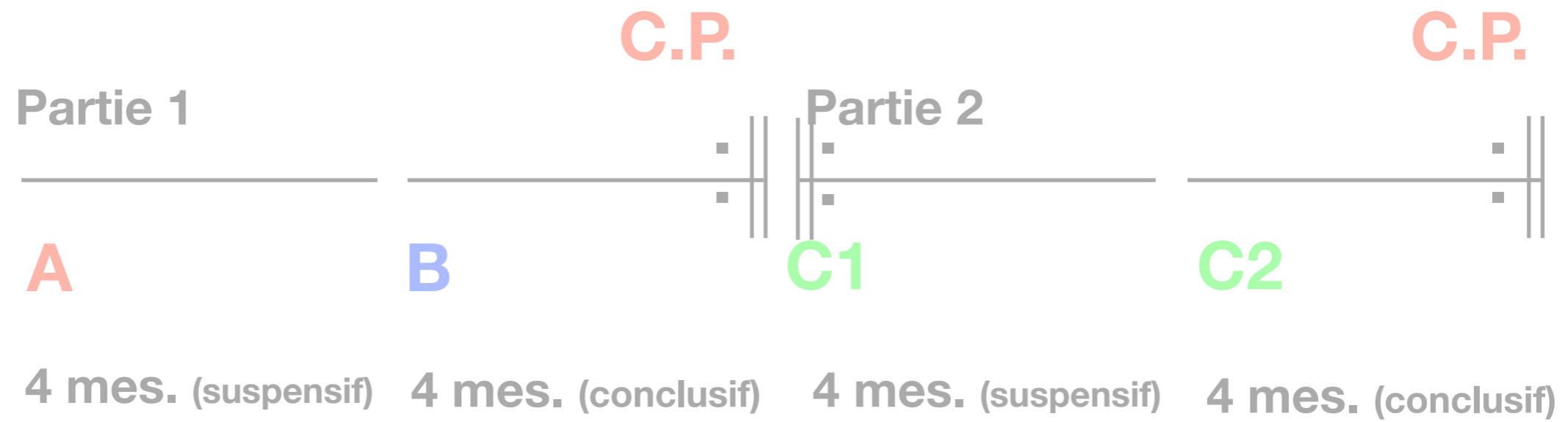

# 26. Menuett in C

KV 6, Menuet I (Klavierfassung)\*\*)

## Partie 1

*Entstanden vermutlich Brüssel, Oktober 1763*

Menuet

Musical score for the first part of the minuet, measures 1-5. The score is written in treble and bass clefs, 3/4 time signature, and C major. A red box highlights the final measure (measure 5) in both staves, which contains a sharp sign on the treble staff and a whole note in the bass staff.

## Partie 2

Musical score for the second part of the minuet, measures 6-10. The score is written in treble and bass clefs, 3/4 time signature, and C major. A red box highlights measures 6-10. A blue box highlights measures 8-10. A yellow box highlights measures 7-10.

Musical score for the third part of the minuet, measures 11-15. The score is written in treble and bass clefs, 3/4 time signature, and C major. A blue box highlights measures 11-15.

# 26. Menuett in C

KV 6, Menuet I (Klavierfassung)\*\*)

*Entstanden vermutlich Brüssel, Oktober 1763*

## Menuet

Musical notation for measures 1-5 of the Minuet. The score is in treble and bass clefs, 3/4 time, and C major. The first four measures are enclosed in a red box, and the fifth measure is enclosed in a blue box. A dashed line above the fifth measure indicates a phrasing slur.

6

Musical notation for measures 6-10 of the Minuet. The score is in treble and bass clefs, 3/4 time, and C major. Measures 6-9 are enclosed in a blue box, and measure 10 is enclosed in a green box. A repeat sign is present at the end of measure 10.

11

Musical notation for measures 11-15 of the Minuet. The score is in treble and bass clefs, 3/4 time, and C major. Measures 11-14 are enclosed in a green box, and measure 15 is enclosed in a blue box. A repeat sign is present at the end of measure 15.

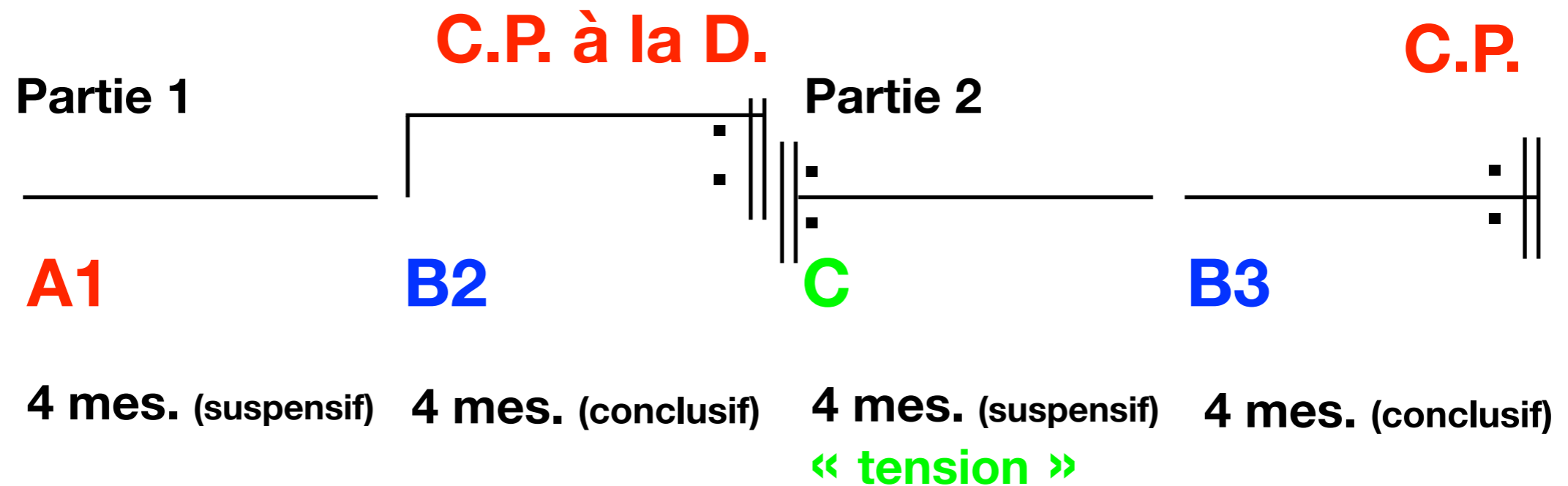
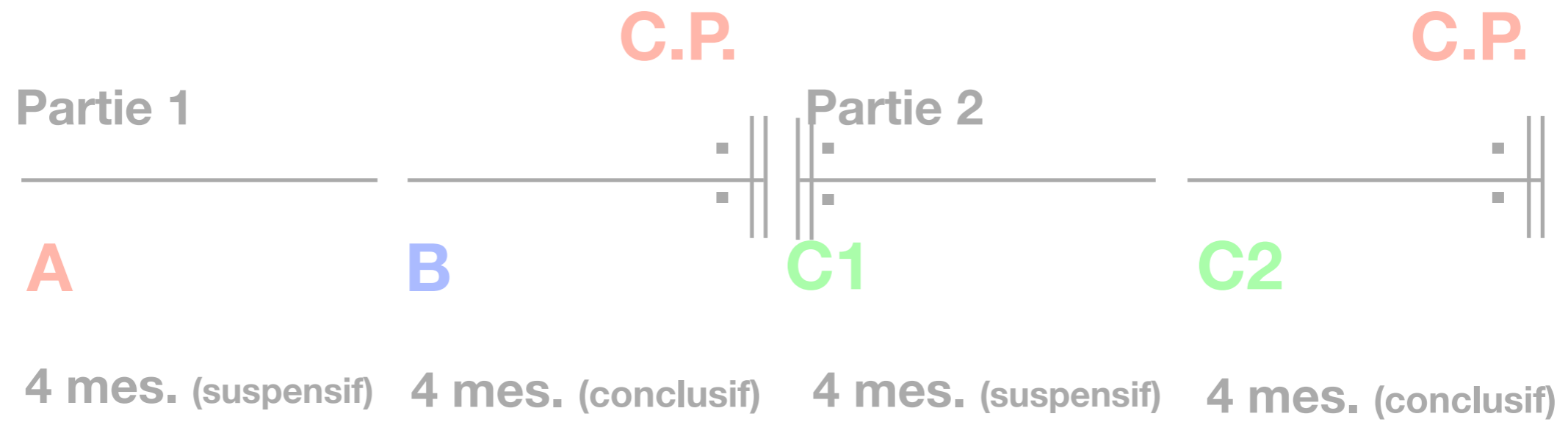

# Haydn

1732 - 1809

Menuet de la sonate Hob. XVI : 8

1760

Musical score for the first system, measures 1-5. The first four measures are enclosed in a red box, and the fifth measure is enclosed in a blue box. The score is in G major, 3/4 time, and features a treble and bass clef. The red box highlights the initial melodic and harmonic material, while the blue box highlights a trill in the treble and a chord in the bass.

**REGISTRE**

Musical score for the second system, measures 6-10. The first five measures are enclosed in a blue box. The sixth and seventh measures are circled in cyan. The score continues in G major, 3/4 time, with triplets and trills in the treble. The cyan circles highlight specific notes in the bass clef.

Musical score for the third system, measures 11-15. The first two measures are circled in cyan. The score continues in G major, 3/4 time, with trills and triplets in the treble. The cyan circles highlight notes in the bass clef.



**Menuet plus long ?**

Menuet

5.

6

11

16

Mendel

5.

6 mesures !!

Nouvelle idée ?

7

11

3

16

tr

**C.P. à la D. Partie 2**

**C.P.**

Partie 1

**A1**

4 mes.

**B1**

$$6 = (2+2) + 2$$

$$4 + 2$$

**A2**

4 mes.

**B2**

$$6 = (2+2) + 2$$

$$4 + 2$$

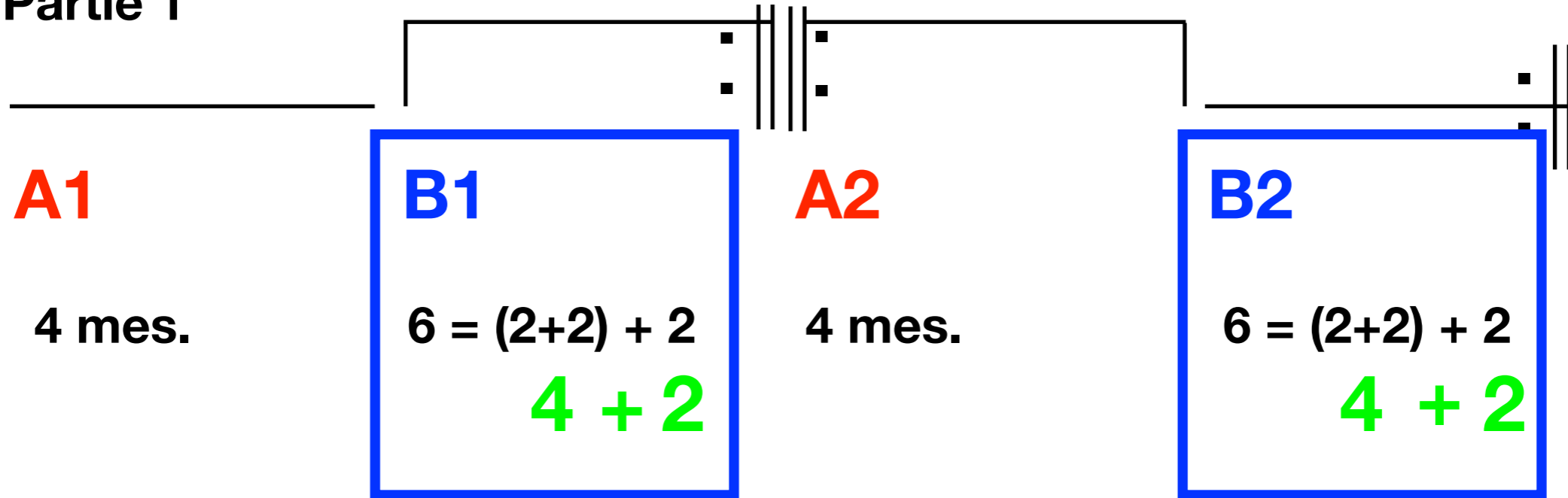

System 1: Treble and Bass clefs, 3/4 time signature, key signature of one flat. The treble staff contains a melodic line with a triplet of eighth notes in the third measure and a repeat sign at the end. The bass staff contains a bass line with a whole rest in the first measure and a repeat sign at the end.

System 2: Treble and Bass clefs, 3/4 time signature, key signature of one flat. The treble staff contains a melodic line with a triplet of eighth notes in the third measure and a repeat sign at the end. The bass staff contains a bass line with a whole rest in the first measure and a repeat sign at the end.

System 3: Treble clef, 3/4 time signature, key signature of one flat. The staff contains a melodic line with a triplet of eighth notes in the third measure and a repeat sign at the end. The final two measures of the system are highlighted with a blue border.

**C.P. à la D.**

**Partie 1**

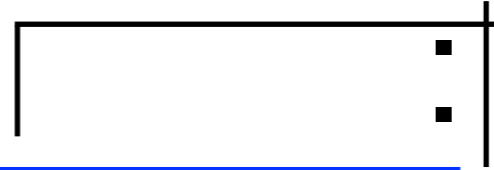

**A1**

**4 mes.**

**B1**

$$6 = 2 + (2 + 2)$$

$$2 + 4$$

KV 4

tr

tr

3

**Nouvelle idée !**

10 mesures

6

\*\*)

3

3

3

14 mesures

1

tr

tr

15

tr

tr

20

3

3

3

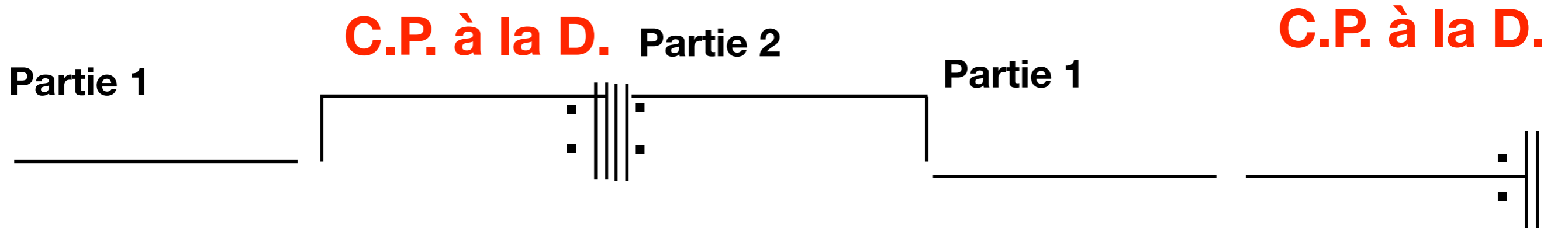

**A1**

4 mes.

**B1**

$6 = (2+2) + 2$

**A2**

4 mes.

**A1**

4 mes.

**B2**

$10 = (2+2) + (2+2) + 2$

**Idée A  
Tonique**

**Idée B  
Dominante**

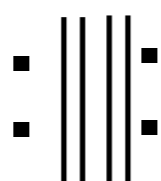

**Idée A  
Dom.**

**Idée A  
Tonique**

**Idée B  
Tonique**

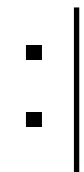

# FORME SONATE

Exposition

Développement Réexposition



Menuett

KV 5

10.

**Idée A  
Tonique**

**Idée B  
Dominante**

6

**Idée B  
tonique**

Développement

11

17

# **Sonatine de Clementi**

**1752 - 1832**

**OP. 36 n°1**

**1797**

KV 2

8 mesures

(Menuett)

7.

3 1 2 4 3 2 4 3

3 3

5

KV 2

16 mesures

3 1 2 3 2 3 3 3 2

2 2

17

3

(Menuett)

KV 2

7.

9

17

# Haydn

## Sonate XVI:2

Menuet.

transition ?

14 mesures

Thème 2 ?

18 mesures

**Menuet encore plus long ?**

**TRIO**

**(2ème menuet)**

Menuet

10 mesures

11.

6

14 mesures

11

15

20

1 r10

tr

tr

7

tr

12

tr

tr

Menuet da capo



# Composer un menuet

**Partimento**

**FRONTE**

Musical score for 'FRONTE' in 3/4 time, key of D major. The score consists of two staves: a treble staff and a bass staff. The first six measures are identical to the 'MONTE' score. The seventh measure is highlighted with a light blue rounded rectangle. The eighth, ninth, and tenth measures are enclosed in a red rectangular box. The eleventh and twelfth measures are also highlighted with light blue rounded rectangles. The notation includes chords and single notes in both staves.

**MONTE**

Musical score for 'MONTE' in 3/4 time, key of D major. The score consists of two staves: a treble staff and a bass staff. The first six measures are identical to the 'FRONTE' score. The seventh measure is highlighted with a light blue rounded rectangle. The eighth, ninth, and tenth measures are enclosed in a red rectangular box. The eleventh and twelfth measures are also highlighted with light blue rounded rectangles. The notation includes chords and single notes in both staves.

**FRONTE**

The first system of music is written for piano in 3/4 time with a key signature of two flats (B-flat and E-flat). The treble clef staff begins with a quarter note G4, followed by a half note F4, a quarter note E4, a half note D4, a quarter note C4, a half note B3, a quarter note A3, and a half note G3. The bass clef staff begins with a quarter rest, followed by a half note G3, a quarter note F3, a half note E3, a quarter note D3, a half note C3, a quarter note B2, and a half note A2. The system concludes with a double bar line and repeat dots.

**FRONTE**

The second system of music starts at measure 9. The treble clef staff features a quarter note G4, a half note F4, a quarter note E4, a half note D4, a quarter note C4, a half note B3, a quarter note A3, and a half note G3. The bass clef staff features a quarter rest, a half note G3, a quarter note F3, a half note E3, a quarter note D3, a half note C3, a quarter note B2, and a half note A2. A red rectangular box highlights the first five measures of this system. The system concludes with a double bar line and repeat dots.

First system of musical notation, consisting of two staves (treble and bass clef) in 3/4 time, key signature of two flats (B-flat and E-flat). The melody in the treble clef features a sequence of eighth and quarter notes, with some notes beamed together. The bass clef accompaniment consists of quarter and eighth notes, often with rests.

Second system of musical notation, continuing the piece. The treble clef melody includes a sharp sign (F#) on the fifth line, indicating a change in the key signature to one flat (B-flat). The bass clef accompaniment continues with similar rhythmic patterns.

Third system of musical notation, starting at measure 9. It features a repeat sign at the beginning. The treble clef melody includes a fermata over a note in the fourth measure. The bass clef accompaniment continues with quarter and eighth notes.

Fourth system of musical notation, also starting at measure 9. The treble clef melody is more active, featuring eighth and sixteenth notes. The bass clef accompaniment includes some chords and rests.

**MOZART**

**K.294d**

**1787**

**50 millions de millions**

**45 949 729 863 572 160**

ANLEITUNG

INSTRUCTION

Walzer oder Schleifer mit zwei  
Würfeln zu componiren, so  
viele man will, ohne  
etwas von der Mufik  
oder Composition  
zu verftehen.

Pour compofer autant de Walzer  
ou Schleifer que l'on veut,  
par le moyen de 2. Dès  
sans favoir la  
Mufique ou la  
Composition.

P A R

**W. A. MOZART.**

INSTRUCTION

ISTRUZIONE

To compose without  
the least knowledge  
of Mufic so much German  
Walzer or Schleifer as  
one pleases, by throwing a  
certain Number with two Dice.

Per comporre  
delle Walzer  
oppure Schleifer  
col mezzo di due Dadi  
senza aver la minima notizia di  
Mufica overo della Composizione.

CHÉZ

**N. Simrock**

**À BONN.**

## 2.1 Mozart K294d

*INSTRUCTION Pour composer autant de Walzes que l'on veut par le moyen de deux Dez sans avoir la moindre connoissance de la Musique ou de la Composition*

- (1) *Les lettres A-H, qui sont placées au-dessus des 8 colonnes des tables de nombres, montrent les 8 mesures de chaque partie de la Walze. Par exemple : A, la première, B, la seconde, C, la troisième, etc., et les nombres dans la colonne de sous les lettres montrent le nombre de la mesure, dans les notes.*
- (2) *Les nombres de 2 jusqu'à 12 montrent la somme du nombre qu'on peut jeter.*
- (3) *On jette donc par exemple, pour la première mesure de la première partie de la Walze, avec 2 dés 6, et cherche près du nombre 6 dans la colonne A, le nombre de la mesure 148 dans la musique. L'on met cette mesure sur le papier et voila ce qui fait le commencement de la Walze. Après cela on jette pour la seconde mesure, par exemple 9. On cherche près de 9 sous B, et on trouve 84 de la table de musique. L'on met cette mesure à côté de la première et l'on continue ainsi jusqu'après avoir jeté les dés huit fois, et alors on a achevé la première partie de la Walze ; ensuite on fait le signe de répétition et commence la 2<sup>nde</sup> partie. Veut-on avoir une Walze plus longue, on recommence de la même manière, et ainsi cela va à l'infini.*

### *Première partie*

	A	B	C	D	E	F	G	H
2	96	22	141	41	105	122	11	30
3	32	6	128	63	146	46	134	81
4	69	95	158	13	153	55	110	24
5	40	17	113	85	161	2	159	100
6	148	74	163	45	80	97	36	107
7	104	157	27	167	154	68	118	91
8	152	60	171	53	99	133	21	127
9	119	84	114	50	140	86	169	94
10	98	142	42	156	75	129	62	123
11	3	87	165	61	135	47	147	33
12	54	130	10	103	28	37	106	5

### *Seconde partie*

	A	B	C	D	E	F	G	H
2	70	121	26	9	112	49	109	14
3	117	39	126	56	174	18	116	83
4	66	139	15	132	73	58	145	79
5	90	176	7	34	67	160	52	170
6	25	143	64	125	76	136	1	93
7	138	71	150	29	101	162	23	151
8	16	155	57	175	43	168	89	172
9	120	88	48	166	51	115	72	111
10	65	77	19	82	137	38	149	8
11	102	4	31	164	144	59	173	78
12	35	20	108	92	12	124	44	131

TABLE de MUSIQUE.

Musical notation for measures 1 through 8. The top staff is in treble clef and the bottom staff is in bass clef. Both are in 3/8 time. Measure 4 has a forte dynamic marking. Measure 5 has a first ending bracket. Measure 6 has a second ending bracket.

Musical notation for measures 9 through 16. The top staff is in treble clef and the bottom staff is in bass clef. Both are in 3/8 time.

Musical notation for measures 17 through 24. The top staff is in treble clef and the bottom staff is in bass clef. Both are in 3/8 time. Measure 24 has a first ending bracket.

Musical notation for measures 25 through 32. The top staff is in treble clef and the bottom staff is in bass clef. Both are in 3/8 time. Measure 30 has a first ending bracket.

Musical notation for measures 33 through 40. The top staff is in treble clef and the bottom staff is in bass clef. Both are in 3/8 time. Measure 33 has a first ending bracket.

Musical notation for measures 41 through 48. The top staff is in treble clef and the bottom staff is in bass clef. Both are in 3/8 time.



49. 50. 51. 52. 53. 54. 55. 56.

This system contains measures 49 through 56. The upper staff is in treble clef and the lower staff is in bass clef. The music consists of eighth and sixteenth notes with various rests and accidentals.

57. 58. 59. 60. 61. 62. 63. 64.

This system contains measures 57 through 64. The notation continues with eighth and sixteenth notes in both staves.

65. 66. 67. 68. 69. 70. 71. 72.

This system contains measures 65 through 72. The key signature changes to one sharp (F#) in measure 65. The notation continues with eighth and sixteenth notes.

73. 74. 75. 76. 77. 78. 79. 80.

This system contains measures 73 through 80. The notation continues with eighth and sixteenth notes in both staves.

81. 82. 83. 84. 85. 86. 87. 88.

This system contains measures 81 through 88. The notation continues with eighth and sixteenth notes. At the end of the system, there are first and second endings indicated by the numbers 1. and 2. below the bass staff.

89. 90. 91. 92. 93. 94. 95. 96.

First system of musical notation, measures 89-96. The treble clef staff contains the melody, and the bass clef staff contains the accompaniment. Measures 91 and 94 feature first and second endings in the bass staff.

97. 98. 99. 100. 101. 102. 103. 104.

Second system of musical notation, measures 97-104. The treble clef staff contains the melody, and the bass clef staff contains the accompaniment. Measure 100 features a first and second ending in the bass staff.

105. 106. 107. 108. 109. 110. 111. 112.

Third system of musical notation, measures 105-112. The treble clef staff contains the melody, and the bass clef staff contains the accompaniment. Measure 107 features a first and second ending in the bass staff.

113. 114. 115. 116. 117. 118. 119. 120.

Fourth system of musical notation, measures 113-120. The treble clef staff contains the melody, and the bass clef staff contains the accompaniment.

121. 122. 123. 124. 125. 126. 127. 128.

Fifth system of musical notation, measures 121-128. The treble clef staff contains the melody, and the bass clef staff contains the accompaniment. Measures 123 and 127 feature first and second endings in the bass staff.

129. 130. 131. 132. 133. 134. 135. 136.

This system contains two staves of music. The upper staff is in treble clef and the lower staff is in bass clef. The music consists of eighth and sixteenth notes with various rests. A key signature of one sharp (F#) is indicated at the beginning of the system.

137. 138. 139. 140. 141. 142. 143. 144.

This system contains two staves of music. The upper staff is in treble clef and the lower staff is in bass clef. A dynamic marking 'h' is present above measure 138. The music continues with eighth and sixteenth notes.

145. 146. 147. 148. 149. 150. 151. 152.

This system contains two staves of music. The upper staff is in treble clef and the lower staff is in bass clef. A dynamic marking 'h' is present above measure 150. The music continues with eighth and sixteenth notes.

153. 154. 155. 156. 157. 158. 159. 160.

This system contains two staves of music. The upper staff is in treble clef and the lower staff is in bass clef. The music continues with eighth and sixteenth notes.

161. 162. 163. 164. 165. 166. 167. 168.

This system contains two staves of music. The upper staff is in treble clef and the lower staff is in bass clef. The music continues with eighth and sixteenth notes.

169. 170. 171. 172. 173. 174. 175. 176.

This system contains two staves of music. The upper staff is in treble clef and the lower staff is in bass clef. The music continues with eighth and sixteenth notes.

*Première partie*

	A	B	C	D	E	F	G	H
2	96	22	141	41	105	122	11	30
3	32	6	128	63	146	46	134	81
4	69	95	158	13	153	55	110	24
5	40	17	113	85	161	2	159	100
6	148	74	163	45	80	97	36	107
7	104	157	27	167	154	68	118	91
8	152	60	171	53	99	133	21	127
9	119	84	114	50	140	86	169	94
10	98	142	42	156	75	129	62	123
11	3	87	165	61	135	47	147	33
12	54	130	10	103	28	37	106	5

*Seconde partie*

	A	B	C	D	E	F	G	H
2	70	121	26	9	112	49	109	14
3	117	39	126	56	174	18	116	83
4	66	139	15	132	73	58	145	79
5	90	176	7	34	67	160	52	170
6	25	143	64	125	76	136	1	93
7	138	71	150	29	101	162	23	151
8	16	155	57	175	43	168	89	172
9	120	88	48	166	51	115	72	111
10	65	77	19	82	137	38	149	8
11	102	4	31	164	144	59	173	78
12	35	20	108	92	12	124	44	131

89. 90. 91. 92. 93. 94. 95. 96.

This system contains measures 89 through 96. The right-hand part features a melodic line with eighth and sixteenth notes, while the left-hand part provides a rhythmic accompaniment with some double bass figures. Measure 96 is highlighted with a red rectangular box.

97. 98. 99. 100. 101. 102. 103. 104.

This system contains measures 97 through 104. The musical notation continues with similar melodic and accompaniment patterns as the previous system.

105. 106. 107. 108. 109. 110. 111. 112.

This system contains measures 105 through 112. The melodic line in the right hand shows some more complex rhythmic patterns.

113. 114. 115. 116. 117. 118. 119. 120.

This system contains measures 113 through 120. The right-hand part continues with a melodic line, and the left-hand part provides accompaniment.

121. 122. 123. 124. 125. 126. 127. 128.

This system contains measures 121 through 128, which are partially visible at the bottom of the page.

2-96

Musical notation for piano in 3/8 time, measures 2-96. The notation is presented in two staves: a treble clef staff (top) and a bass clef staff (bottom). The treble staff contains three eighth notes: G4, A4, and B4. The bass staff contains a single eighth note: G3. A brace on the left side of the staves indicates that this is a piano accompaniment.

*Première partie*

	A	B	C	D	E	F	G	H
2	96	22	141	41	105	122	11	30
3	32	6	128	63	146	46	134	81
4	69	95	158	13	153	55	110	24
5	40	17	113	85	161	2	159	100
6	148	74	163	45	80	97	36	107
7	104	157	27	167	154	68	118	91
8	152	60	171	53	99	133	21	127
9	119	84	114	50	140	86	169	94
10	98	142	42	156	75	129	62	123
11	3	87	165	61	135	47	147	33
12	54	130	10	103	28	37	106	5

*Seconde partie*

	A	B	C	D	E	F	G	H
2	70	121	26	9	112	49	109	14
3	117	39	126	56	174	18	116	83
4	66	139	15	132	73	58	145	79
5	90	176	7	34	67	160	52	170
6	25	143	64	125	76	136	1	93
7	138	71	150	29	101	162	23	151
8	16	155	57	175	43	168	89	172
9	120	88	48	166	51	115	72	111
10	65	77	19	82	137	38	149	8
11	102	4	31	164	144	59	173	78
12	35	20	108	92	12	124	44	131

Musical notation for measures 129-136. The system consists of two staves: a treble clef staff on top and a bass clef staff on the bottom. The treble staff contains a melodic line with various note values and rests. The bass staff contains a bass line with similar note values and rests. Measure numbers 129, 130, 131, 132, 133, 134, 135, and 136 are printed below the treble staff.

Musical notation for measures 137-144. The system consists of two staves: a treble clef staff on top and a bass clef staff on the bottom. The treble staff contains a melodic line with various note values and rests. The bass staff contains a bass line with similar note values and rests. Measure numbers 137, 138, 139, 140, 141, 142, 143, and 144 are printed below the treble staff. A dynamic marking *h* is present above measure 138.

Musical notation for measures 145-152. The system consists of two staves: a treble clef staff on top and a bass clef staff on the bottom. The treble staff contains a melodic line with various note values and rests. The bass staff contains a bass line with similar note values and rests. Measure numbers 145, 146, 147, 148, 149, 150, 151, and 152 are printed below the treble staff. A dynamic marking *h* is present above measure 150.

Musical notation for measures 153-160. The system consists of two staves: a treble clef staff on top and a bass clef staff on the bottom. The treble staff contains a melodic line with various note values and rests. The bass staff contains a bass line with similar note values and rests. Measure numbers 153, 154, 155, 156, 157, 158, 159, and 160 are printed below the treble staff. A red rectangular box highlights the musical notation for measure 157.

Musical notation for measures 161-168. The system consists of two staves: a treble clef staff on top and a bass clef staff on the bottom. The treble staff contains a melodic line with various note values and rests. The bass staff contains a bass line with similar note values and rests. Measure numbers 161, 162, 163, 164, 165, 166, 167, and 168 are printed below the treble staff.

Musical notation for measures 169-176. The system consists of two staves: a treble clef staff on top and a bass clef staff on the bottom. The treble staff contains a melodic line with various note values and rests. The bass staff contains a bass line with similar note values and rests. Measure numbers 169, 170, 171, 172, 173, 174, 175, and 176 are printed below the treble staff.





*Première partie*

	A	B	C	D	E	F	G	H
2	96	22	141	41	105	122	11	30
3	32	6	128	63	146	46	134	81
4	69	95	158	13	153	55	110	24
5	40	17	113	85	161	2	159	100
6	148	74	163	45	80	97	36	107
7	104	157	27	167	154	68	118	91
8	152	60	171	53	99	133	21	127
9	119	84	114	50	140	86	169	94
10	98	142	42	156	75	129	62	123
11	3	87	165	61	135	47	147	33
12	54	130	10	103	28	37	106	5

*Seconde partie*

	A	B	C	D	E	F	G	H
2	70	121	26	9	112	49	109	14
3	117	39	126	56	174	18	116	83
4	66	139	15	132	73	58	145	79
5	90	176	7	34	67	160	52	170
6	25	143	64	125	76	136	1	93
7	138	71	150	29	101	162	23	151
8	16	155	57	175	43	168	89	172
9	120	88	48	166	51	115	72	111
10	65	77	19	82	137	38	149	8
11	102	4	31	164	144	59	173	78
12	35	20	108	92	12	124	44	131

Musical notation for measures 129-136. The system consists of two staves: a treble clef staff on top and a bass clef staff on the bottom. The treble staff contains a melodic line with various note values and rests. The bass staff contains a bass line with chords and single notes. Measure numbers 129, 130, 131, 132, 133, 134, 135, and 136 are printed below the treble staff.

Musical notation for measures 137-144. The system consists of two staves: a treble clef staff on top and a bass clef staff on the bottom. The treble staff contains a melodic line with various note values and rests. The bass staff contains a bass line with chords and single notes. Measure numbers 137, 138, 139, 140, 141, 142, 143, and 144 are printed below the treble staff. A dynamic marking *h* is present above measure 138.

Musical notation for measures 145-152. The system consists of two staves: a treble clef staff on top and a bass clef staff on the bottom. The treble staff contains a melodic line with various note values and rests. The bass staff contains a bass line with chords and single notes. Measure numbers 145, 146, 147, 148, 149, 150, 151, and 152 are printed below the treble staff. A dynamic marking *h* is present above measure 150.

Musical notation for measures 153-160. The system consists of two staves: a treble clef staff on top and a bass clef staff on the bottom. The treble staff contains a melodic line with various note values and rests. The bass staff contains a bass line with chords and single notes. Measure numbers 153, 154, 155, 156, 157, 158, 159, and 160 are printed below the treble staff.

Musical notation for measures 161-168. The system consists of two staves: a treble clef staff on top and a bass clef staff on the bottom. The treble staff contains a melodic line with various note values and rests. The bass staff contains a bass line with chords and single notes. Measure numbers 161, 162, 163, 164, 165, 166, 167, and 168 are printed below the treble staff. A red rectangular box highlights the musical notation for measure 165 in both the treble and bass staves.

Musical notation for measures 169-176. The system consists of two staves: a treble clef staff on top and a bass clef staff on the bottom. The treble staff contains a melodic line with various note values and rests. The bass staff contains a bass line with chords and single notes. Measure numbers 169, 170, 171, 172, 173, 174, 175, and 176 are printed below the treble staff.

2-96

7-157

11-165

Musical score for piano in 3/8 time, consisting of three measures. The right hand (treble clef) plays a melody of eighth notes. The left hand (bass clef) plays a simple accompaniment of quarter notes with grace notes.

Measure 1 (2-96): Right hand: G4, A4, B4, A4, G4. Left hand: G3, grace note, G3.

Measure 2 (7-157): Right hand: G4, A4, B4, C5, B4, A4, G4. Left hand: G3, grace note, G3.

Measure 3 (11-165): Right hand: G4, A4, B4, A4, G4. Left hand: G3, grace note, G3.

*Première partie*

	A	B	C	D	E	F	G	H
2	96	22	141	41	105	122	11	30
3	32	6	128	63	146	46	134	81
4	69	95	158	13	153	55	110	24
5	40	17	113	85	161	2	159	100
6	148	74	163	45	80	97	36	107
7	104	157	27	167	154	68	118	91
8	152	60	171	53	99	133	21	127
9	119	84	114	50	140	86	169	94
10	98	142	42	156	75	129	62	123
11	3	87	165	61	135	47	147	33
12	54	130	10	103	28	37	106	5

*Seconde partie*

	A	B	C	D	E	F	G	H
2	70	121	26	9	112	49	109	14
3	117	39	126	56	174	18	116	83
4	66	139	15	132	73	58	145	79
5	90	176	7	34	67	160	52	170
6	25	143	64	125	76	136	1	93
7	138	71	150	29	101	162	23	151
8	16	155	57	175	43	168	89	172
9	120	88	48	166	51	115	72	111
10	65	77	19	82	137	38	149	8
11	102	4	31	164	144	59	173	78
12	35	20	108	92	12	124	44	131

2-96

7-157

11-165

8-53

Musical score for piano in 3/8 time, consisting of four measures. The first measure (2-96) shows a treble clef with a quarter note G4, an eighth note A4, and a quarter note B4. The bass clef has a quarter note G3 and a quarter rest. The second measure (7-157) features a treble clef with a sixteenth note G4, a sixteenth note A4, a sixteenth note B4, a sixteenth note C5, a sixteenth note B4, a sixteenth note A4, and a quarter note G4. The bass clef has a quarter note G3 and a quarter rest. The third measure (11-165) has a treble clef with a quarter note G4, an eighth note A4, and a quarter note B4. The bass clef has a quarter note G3 and a quarter rest. The fourth measure (8-53) shows a treble clef with a quarter note G4, an eighth note A4, and a quarter note B4. The bass clef has a quarter note G3 and a quarter rest.

2-96

7-157

11-165

8-53

5-161

3-46

9-169

4-24

A musical score for piano in 3/8 time, consisting of two staves. The score is divided into eight measures, each with a chord symbol above it. The first seven measures are followed by a double bar line and a repeat sign, and then a final measure. The notation includes various note values (quarter, eighth, and sixteenth notes), rests, and accidentals (sharps and naturals). The bass staff often features a single note with a grace note, while the treble staff has more complex melodic and harmonic patterns.

2-96

7-157

11-165

8-53

5-161

3-46

9-169

4-24

The first system of music consists of two staves. The treble staff begins with a treble clef and a 3/8 time signature. It contains eight measures of music. The first measure has a quarter note G4 and a quarter note A4. The second measure has a quarter note G4, a quarter note A4, and a quarter note B4. The third measure has a quarter note G4 and a quarter note A4. The fourth measure has a quarter note G4, a quarter note A4, and a quarter note B4. The fifth measure has a quarter note G4, a quarter note A4, and a quarter note B4. The sixth measure has a quarter note G4, a quarter note A4, and a quarter note B4. The seventh measure has a quarter note G4, a quarter note A4, and a quarter note B4. The eighth measure has a quarter note G4, a quarter note A4, and a quarter note B4. The bass staff begins with a bass clef and a 3/8 time signature. It contains eight measures of music. The first measure has a quarter rest. The second measure has a quarter rest. The third measure has a quarter rest. The fourth measure has a quarter rest. The fifth measure has a quarter note G3, a quarter note A3, and a quarter note B3. The sixth measure has a quarter note G3, a quarter note A3, and a quarter note B3. The seventh measure has a quarter note G3, a quarter note A3, and a quarter note B3. The eighth measure has a quarter note G3, a quarter note A3, and a quarter note B3.

2-96

9-84

5-113

2-41

The second system of music consists of two staves. The treble staff begins with a treble clef and a 3/8 time signature. It contains four measures of music. The first measure has a quarter note G4 and a quarter note A4. The second measure has a quarter note G4, a quarter note A4, and a quarter note B4. The third measure has a quarter note G4 and a quarter note A4. The fourth measure has a quarter note G4, a quarter note A4, and a quarter note B4. The bass staff begins with a bass clef and a 3/8 time signature. It contains four measures of music. The first measure has a quarter rest. The second measure has a quarter rest. The third measure has a quarter rest. The fourth measure has a quarter rest.

2-96

10-42

5-113

12-103

The third system of music consists of two staves. The treble staff begins with a treble clef and a 3/8 time signature. It contains four measures of music. The first measure has a quarter note G4 and a quarter note A4. The second measure has a quarter note G4 and a quarter note A4. The third measure has a quarter note G4 and a quarter note A4. The fourth measure has a quarter note G4, a quarter note A4, and a quarter note B4. The bass staff begins with a bass clef and a 3/8 time signature. It contains four measures of music. The first measure has a quarter rest. The second measure has a quarter rest. The third measure has a quarter rest. The fourth measure has a quarter rest.



2-96

7-157

11-165

8-53

5-161

3-46

9-169

4-24

I V I V I IV V I

A la dominante

**Menuet encore un peu  
plus long ?**

**SCHUBERT**

**D.335**

**2 TRIOS !**

First system of musical notation, featuring treble and bass staves. The key signature is three sharps (F#, C#, G#) and the time signature is 3/4. The music includes a forte (*f*) dynamic marking and a trill (*tr*) in the first measure of the treble staff.

Second system of musical notation, continuing the piece. The key signature and time signature remain the same. A piano (*p*) dynamic marking is present in the second measure.

Third system of musical notation, featuring a piano-piano (*pp*) dynamic marking in the second measure and a forte (*f*) dynamic marking in the fifth measure.

Fourth system of musical notation, concluding the section with a repeat sign at the end.

**Trio I.**

First system of the Trio I section, starting with a piano (*p*) dynamic marking. The key signature and time signature remain the same.

Second system of the Trio I section, featuring a repeat sign and a change in the bass staff.

First system of a musical score in 3/4 time, key of D major. The right hand features a melodic line with a triplet of eighth notes in the first measure. A red box highlights a specific passage in the right hand starting in the third measure, consisting of a quarter note G4, an eighth note A4, and a quarter note B4.

Second system of the musical score. The right hand continues the melodic line. A dynamic marking of *p* (piano) is present in the second measure. The system concludes with a repeat sign.

Third system of the musical score. A red box highlights a passage in the right hand starting in the first measure, featuring a melodic line with a triplet of eighth notes. A dynamic marking of *pp* (pianissimo) is present in the second measure.

Fourth system of the musical score, continuing the melodic development in the right hand. The system concludes with a repeat sign.

**Trio I.**

Fifth system of the musical score, the beginning of the Trio I section. The right hand features a melodic line with a triplet of eighth notes. A dynamic marking of *p* (piano) is present in the first measure.

Sixth system of the musical score, continuing the Trio I section. The right hand features a melodic line with a triplet of eighth notes. The system concludes with a repeat sign.

First system of musical notation, featuring a piano accompaniment with a red rectangular box highlighting the first four measures.

Second system of musical notation, continuing the piano accompaniment.

M. D. C.

**Trio II.**

Third system of musical notation, beginning the Trio II section with a forte (*fz*) dynamic marking.

Fourth system of musical notation, continuing the Trio II section.

Fifth system of musical notation, continuing the Trio II section with a forte (*fz*) dynamic marking.

Sixth system of musical notation, concluding the Trio II section with a forte (*fz*) dynamic marking.

M. D. C.

**Le menuet :  
un terrain de recherche.**

# Haydn

## Symphonie 47

1772

# III

## Menuet

2 Oboi

2 Corni in G/Sol

Violino I

Violino II

Viola

Violoncello,  
Basso  
e Fagotto

This system of the musical score includes five staves. The top staff is for 2 Oboes, the second for 2 Horns in G/Sol, the third and fourth for Violino I and Violino II, the fifth for Viola, and the bottom for Violoncello, Basso, and Fagotto. The music is in 3/4 time with a key signature of one sharp (F#). The first measure is marked with a first ending bracket and a second ending bracket. Dynamics include *f*, *p*, and *fp*.

This system continues the musical score with five staves. The top staff is for 2 Oboes, the second for 2 Horns in G/Sol, the third and fourth for Violino I and Violino II, the fifth for Viola, and the bottom for Violoncello, Basso, and Fagotto. The music continues in 3/4 time with a key signature of one sharp (F#). Dynamics include *p*, *f*, and *fp*.



Musical score for measures 1-10. The score is in 3/4 time with a key signature of one sharp (F#). It consists of three staves: Treble, Middle, and Bass. The dynamics are marked as *f* (forte) and *p* (piano). A red arrow points from the end of measure 10 to the right.

Measure 1: Treble *f* (quarter), Middle *f* (quarter), Bass *f* (quarter).  
Measure 2: Treble *p* (quarter), Middle *p* (quarter), Bass *p* (quarter).  
Measure 3: Treble *f* (quarter), Middle *f* (quarter), Bass *f* (quarter).  
Measure 4: Treble *p* (quarter), Middle *p* (quarter), Bass *p* (quarter).  
Measure 5: Treble *f* (quarter), Middle *f* (quarter), Bass *f* (quarter).  
Measure 6: Treble *p* (quarter), Middle *p* (quarter), Bass *p* (quarter).  
Measure 7: Treble *f* (quarter), Middle *f* (quarter), Bass *f* (quarter).  
Measure 8: Treble *p* (quarter), Middle *p* (quarter), Bass *p* (quarter).  
Measure 9: Treble *f* (quarter), Middle *f* (quarter), Bass *f* (quarter).  
Measure 10: Treble *p* (quarter), Middle *p* (quarter), Bass *p* (quarter).

Musical score for measures 11-20. The score is in 3/4 time with a key signature of one sharp (F#). It consists of three staves: Treble, Middle, and Bass. The dynamics are marked as *p* (piano) and *f* (forte). A red arrow points from the end of measure 20 to the left.

Measure 11: Treble *p* (quarter), Middle *p* (quarter), Bass *p* (quarter).  
Measure 12: Treble *f* (quarter), Middle *f* (quarter), Bass *f* (quarter).  
Measure 13: Treble *p* (quarter), Middle *p* (quarter), Bass *p* (quarter).  
Measure 14: Treble *f* (quarter), Middle *f* (quarter), Bass *f* (quarter).  
Measure 15: Treble *p* (quarter), Middle *p* (quarter), Bass *p* (quarter).  
Measure 16: Treble *f* (quarter), Middle *f* (quarter), Bass *f* (quarter).  
Measure 17: Treble *p* (quarter), Middle *p* (quarter), Bass *p* (quarter).  
Measure 18: Treble *f* (quarter), Middle *f* (quarter), Bass *f* (quarter).  
Measure 19: Treble *p* (quarter), Middle *p* (quarter), Bass *p* (quarter).  
Measure 20: Treble *f* (quarter), Middle *f* (quarter), Bass *f* (quarter).

4

+2 = 6

4

Musical score for the first system, measures 1-6. The score is in 3/4 time with a key signature of one sharp (F#). It consists of three staves: Treble, Alto, and Bass clefs. The music is divided into sections: a solid red box covers measures 1-4, a dashed red box covers measures 5-6, and a solid blue box covers measures 7-10. Dynamics include forte (f) and piano (p).

3

2

2

3

Musical score for the second system, measures 7-12. The score is in 3/4 time with a key signature of one sharp (F#). It consists of three staves: Treble, Alto, and Bass clefs. The music is divided into sections: a solid red box covers measures 7-9, a dashed red box covers measures 10-11, and a solid blue box covers measures 12-14. Dynamics include forte (f) and piano (p).

**5** **2** **5**

Trio

21

*p*

Musical score for Trio starting at measure 21. The score is divided into three sections: a red solid box (measures 21-23), a cyan dashed box (measures 24-25), and a blue solid box (measures 26-28). A light blue rounded rectangle highlights the final three measures (26-28).

**4** **+2 = 6** **2** **4**

33

*p*

*p*

*p*

Musical score for Menuet da capo starting at measure 33. The score is divided into four sections: a red solid box (measures 33-36), a red dashed box (measures 37-38), a cyan dashed box (measures 39-40), and a blue solid box (measures 41-44). A light blue rounded rectangle highlights the final four measures (41-44).

Menuet da capo

# Haydn

quatuor op. 20 n°4 - Menuet

**1772**

vl1

vl2

Alt

Vc

*f*

*fz*

*fz*

*fz*

*fz*

*fz*

*fz*

*fz*

# Gavotte

2  
2

4

*fz*

*fz*

*fz*

*fz*

*fz*

*fz*

Violin I (vI1) and Violoncello (Vc) parts are highlighted with red boxes. A blue box highlights a section in the Violin I part. The score includes dynamic markings such as *fz* and *sf*.

Violin I (vI1) part is highlighted with a red box. A blue box highlights a section in the Violin I part, with three blue circles around specific notes. The score includes dynamic markings such as *fz* and *sf*.