

## Cylinderfäste nr 02 = fläns i bakkant

Med ledlager ( 01 ) eller utvändig gänga ( 05 ) alt. Invändig gänga ( 06 )

Cylinder Diameter	Ø	B	C	E	F	G	H	I	J	K	L	M	N	O	P	Q	R	NV	S	Tryck	Drag
																				area mm <sup>2</sup>	area mm <sup>2</sup>
50/40	25	18	45	50	127	G 1/4"	50	25	16	20	14	24	M18x1.5	85	70	9	15	22	10	1256	765
60/50	30	18	50	55	132	G 3/8"	60	30	20	25	18	32	M20	95	80	9	15	26	12	1962	1255
60/50	32	18	50	55	132	G 3/8"	60	30	20	25	18	32	M20	95	80	9	15	27	12	1962	1158
73/63	32	23	55	55	141	G 3/8"	70	30	22	30	18	32	M20	130	110	11	20	27	12	3116	2312
73/63	40	23	55	55	141	G 3/8"	70	30	22	30	18	36	M24	130	110	11	20	34	12	3116	1860
80/70	40	23	55	55	145	G 3/8"	70	30	22	30	18	36	M24	148	120	14	20	34	12	3846	2590
95/80	40	23	70	70	166	G 1/2"	90	40	28	35	21	36	M24	159	138	14	20	34	12	5024	3768
95/80	50	23	70	70	166	G 1/2"	90	40	28	35	21	45	M33x2	159	138	14	20	43	15	5024	3061
105/90	50	33	75	70	181	G 1/2"	100	50	32	40	21	45	M33x2	185	158	18	25	43	15	6360	4398
115/100	50	33	85	70	185	G 1/2"	120	50	35	50	21	45	M33x2	195	168	18	25	43	15	7850	5887
115/100	60	33	85	70	185	G 1/2"	120	50	35	50	21	56	M42x2	195	168	18	25	56	20	7850	4734
130/110	60	35	90	73	193	G 3/4"	120	50	35	50	23	56	M40x2	218	180	21	30	54	20	9498	6672
130/110	63	35	90	73	193	G 3/4"	120	50	35	50	23	56	M42x2	218	180	21	30	56	20	9498	6382
135/120	50	33	90	73	193	G 3/4"	120	50	35	50	23	45	M33x2	228	190	21	30	43	20	11304	9341
135/120	60	35	90	73	193	G 3/4"	120	50	35	50	23	53	M40x2	228	190	21	30	54	20	11304	8478
145/125	63	40	90	73	209	G 3/4"	140	60	44	60	23	56	M42x2	238	200	21	35	56	20	12266	9150
160/140	63	40	110	73	205	G 3/4"	140	60	44	60	23	56	M42x2	258	225	21	35	56	20	15386	12270
160/140	80	40	110	73	205	G 3/4"	140	60	44	60	23	70	M52x2	258	225	21	35	72	20	15386	10362
180/160	80	40	140	90	225	G 3/4"	180	60	49	70	23	70	M52x2	298	252	21	40	72	20	20096	15072
205/180	80	45	140	90	260	G 3/4"	180	60	49	70	23	70	M52x2	330	284	25	40	72	20	25434	20410

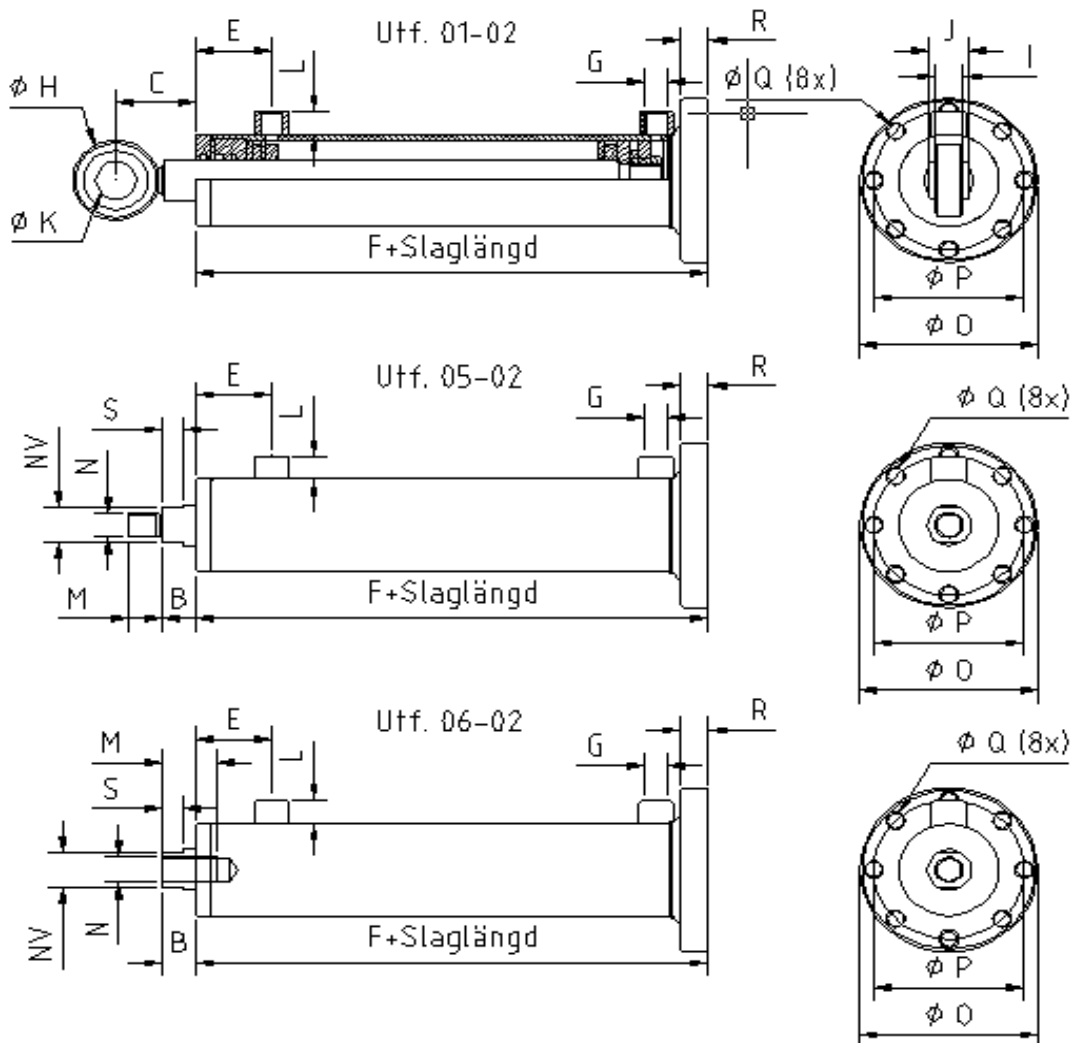

Vi förbehåller oss rätten till ändringar

---

**www.hydmek.se tel: 0372-30532 fax:0372-35294**