



## Gas cooler series RC 1.2+

In emission measurement, process control relies on prompt and exact determination of the operating parameters.

Here, gas analysis is the key for safe and efficient control of process flows, environmental protection and quality assurance. This benefits controlling flue gas emission in power stations as well as measurements in small combustion plants or exhaust gas analysis in automotive engineering.

Many of the analysis processes used in these fields require extracting the sample gas. This inevitably also extracts process-related contamination such as particles or moisture. These in turn can impact the measurement results or damage the measuring cells. The sample gas must therefore be conditioned before entering the analyser.

The RC 1.2+ series features a new generation heat exchangers with a particularly low wash out effect of water-soluble components and are specifically suitable for measuring emissions. Most notably, the washout of SO<sub>2</sub> is low. These coolers can therefore be used for so-called automated measuring systems (AMS) per EN 15267-3.

Low wash out effects

Compact installation

One gas path with two in-line heat exchangers

Duran glass heat exchanger

Bühler constant control system

Self-monitoring

Cooling block temperature display

Status alarm

Rated cooling power 390 kJ/h

Dew point stability 0.1 °C

CFC-free



## Performance data

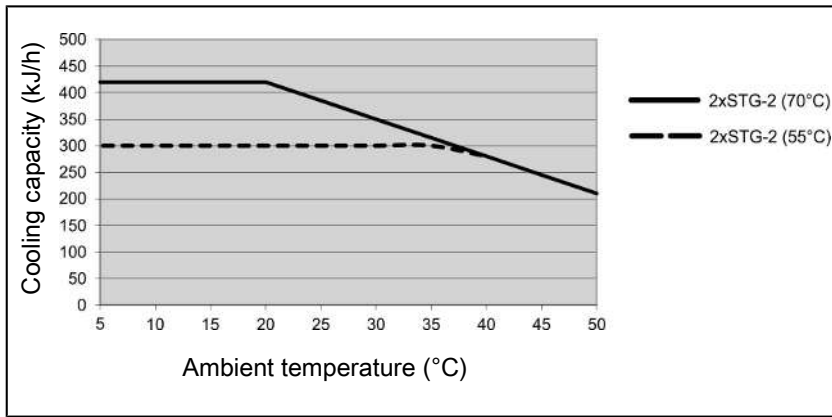

Note: The limit curves of the heat exchangers apply to different dew points, see legend.

## Technical Data

### Gas Cooler Technical Data

Operational readiness:	after max. 15 minutes		
Rated cooling capacity (at 25 °C):	390 kJ/h		
Ambient temperature:	5 °C to 50 °C		
Gas outlet dew temperature, preset:	5 °C		
Dew point fluctuations static:	0.1 K		
in the entire specification range:	± 1.5 K		
IP rating:	IP 20		
Housing:	Stainless steel		
Weight incl. heat exchanger:	approx. 15.5 kg		
Electric supply:	115 V, 60 Hz or 230 V, 50 Hz Plug per DIN EN 175301-803		
Electrical data:	230 V	115 V	
	Typical power input:	396 VA	402 VA
	max. operating current:	2.5 A	5 A
Alarm output switching connection:	250 V, 2 A, 50 VA Plug per DIN EN 175301-803		
Packaging dimensions:	approx. 420 mm x 440 mm x 350 mm		

## Technical Data - Options

### CPdouble Peristaltic Pump Technical Data

Flow rate:	0.3 L/h (50 Hz) / 0.36 L/h (60 Hz) with standard hose
Inlet vacuum:	max. 0.8 bar
Inlet pressure:	max. 1 bar
Output pressure:	1 bar
Hose:	4 x 1.6 mm
Protection class:	IP 40
Materials	
Hose:	Norprene (standard), Marprene, Fluran
Connections:	PVDF

### Technical Data FF-3-N Moisture Detector

Ambient temperature	3 °C to 50 °C
max. operating pressure with FF-3-N	2 bar
Material	PVDF, PTFE, epoxy resin, stainless steel 1.4571, 1.4576

**AGF-PV-30-F2 Filter Technical Data**

Ambient temperature	3 °C to 100 °C
max. operating pressure with filter	2 bar
Filter surface	60 cm <sup>2</sup>
Filter mesh	2 µm
Dead volume	57 ml
<b>Materials</b>	
Filter:	PVDF, Duran glass (parts in contact with mediums)
Seal:	Viton
Filter element:	sintered PTFE

**Diagram typical installation**

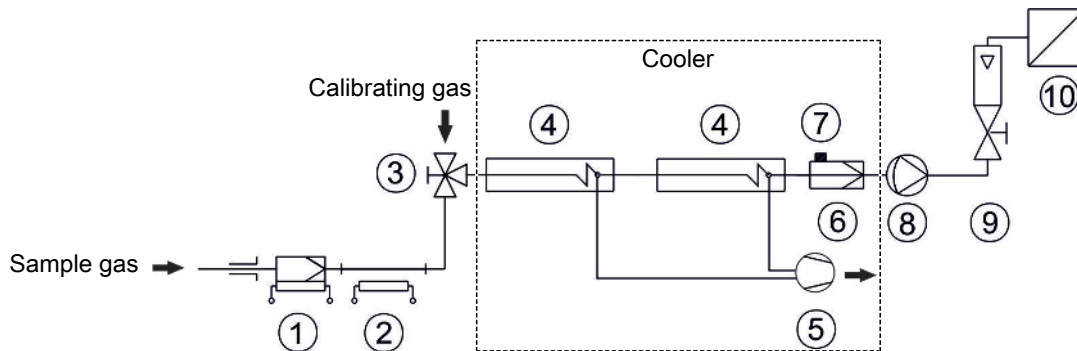

1 Sample gas probe	6 Moisture detector
2 Sample gas line	7 Fine mesh filter
3 Reversing tap	8 Sample gas pump
4 Sample gas cooler	9 Flow meter
5 Automatic condensate drain or peristaltic pump	10 Analyser

See data sheets for individual component types and data.

**Heat exchanger description**

The energy content of the sample gas and the required cooling capacity of the gas cooler is determined by three parameters: gas temperature  $\vartheta_G$ , dew point  $\tau_e$  (moisture content) and volume flow  $v$ . The outlet dew point rises with increasing energy content of the gas. The approved energy load from the gas is therefore determined by the tolerated rise in the dew point.

The following limits are specified for a standard operating point of  $\tau_e = 70\text{ °C}$  and  $\vartheta_G = 110\text{ °C}$ . The maximum volume flow  $v_{max}$  in NI/h of cooled air is indicated, so after moisture has condensed.

If the values fall below  $\tau_e$  and  $\vartheta_G$ , the flow  $v_{max}$  may be increased. For example, with the STG heat exchanger in place of  $\tau_e = 70\text{ °C}$ ,  $\vartheta_G = 110\text{ °C}$  and  $v = 320\text{ NI/h}$  the parameter triple  $\tau_e = 50\text{ °C}$ ,  $\vartheta_G = 105\text{ °C}$  and  $v = 420\text{ NI/h}$  may also be used.

Please contact our experts for clarification or refer to our design program.

**Heat exchanger overview**

Heat exchanger	2x STG-2
Version/Material	Glass
Flow rate $v_{max}$ <sup>1)</sup>	320 L/h
Inlet dew point $\tau_{e,max}$ <sup>1)</sup>	70 °C
Gas inlet temperature $\vartheta_{G,max}$ <sup>1)</sup>	140 °C
Max. Cooling capacity $Q_{max}$	345 kJ/h
Gas connections (metric)	GL 14 (6 mm) <sup>2)</sup>
Gas connections (US)	GL 14 (1/4") <sup>2)</sup>
Condensate out connection (metric)	GL 18 (10 mm) <sup>2)</sup>
Condensate out connection (US)	GL 18 (10 mm) <sup>2)</sup>

<sup>1)</sup> Max. cooling capacity of the cooler must be considered

<sup>2)</sup> Gasket inside diameter

Dimensions

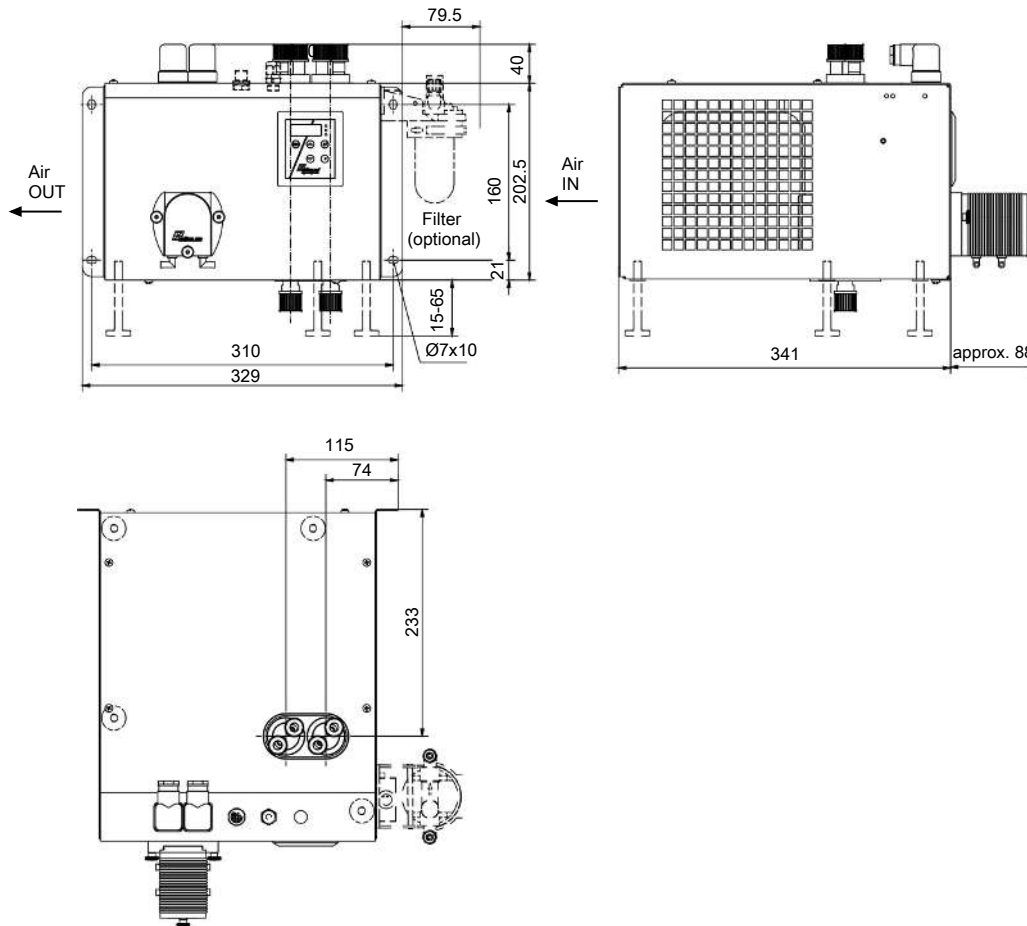

Ordering instructions

Gas cooler

The item number is a code for the configuration of your unit. Please use the following model key:

4596	2	1	2	0	X	X	X	X	X	0	X	X	X	0	0	0	0	0	0	Product Characteristics																						
																			<b>Voltage</b>																							
																			1																		115 V, 60 Hz					
																			2																				230 V, 50 Hz			
																			<b>Heat exchanger</b>																							
																			1	2	2																		1 gas path/ 2 heat exchangers, glass/ (STG-2), metric			
																			1	2	7																			1 gas path/ 2 heat exchangers, glass/ (STG-2), US		
																			<b>Condensate drain <sup>1)</sup></b>																							
																			0	0																				without condensate drain		
																			2	0																					CPdouble with hose nipple, angled <sup>2)</sup>	
																			4	0																					CPdouble with screw connection, metric/US <sup>2)</sup>	
																			<b>Filter</b>																							
																			0																						without filter	
																			1																							1 filter
																			<b>Moisture detector</b>																							
																			0																							without moisture detector
																			1																							1 moisture detector
																			<b>Status outputs</b>																							
																			0																							status output only
																			1																							Analog output option, add-on

<sup>1)</sup> Peristaltic pumps also available for separate installation, see data sheet 450020.

<sup>2)</sup> Each gas path equipped with a peristaltic pump. The supply voltage corresponds with that of the main unit.

**Consumables and accessories**

<b>Item no.</b>	<b>Description</b>
44 10 00 1	Automatic condensate drain 11 LD V 38
44 10 00 4	Automatic condensate drain AK 20, PVDF
44 10 00 5	Condensate trap GL 1; glass, 0.4 L
441 00 19	Condensate trap GL 2; glass, 1 L
4492 0035 012	Norprene replacement hose with angled connections for CP peristaltic pump 0.3 L/h
4492 0035 016	Norprene replacement hose with one angled connection and one screw connection (metric) for CP peristaltic pump 0.3 L/h
4492 0035 017	Norprene replacement hose with one angled connection and one screw connection (US) for CP peristaltic pump 0.3 L/h