

- **High strength stainless steel body**
 - the body is corrosion resistant stainless steel, rigidly constructed to maintain tube alignment and resist pipe strain
- **'SNAP-IN' tube construction**
 - minimizes the downtime needed to clean the meter tube or to change the meter range
- **Polycarbonate operator protection shield**
 - safety tested shield protects personnel from glass fragments in the rare event of accidental tube breakage
- **Component flexibility**
 - all parts for the three scale lengths except bodies, tubes and protector shields are interchangeable
- **Internal backcheck**
 - restricts back flow and draining of process fluid when metering tube is removed
- **Choice of operating position**
 - the meter can be inverted and its tube reversed to change the control valve position from the inlet to the outlet
- **Options of valve, DP regulator and alarms**



**Long-term reliable performance
flowmeters with low cost of
ownership**

Introduction

ABB Purgemaster Flowmeters are low capacity variable area flowmeters for both liquid and gas with an excellent selection of material and scale lengths in a single product family design. They provide optimum flexibility with a minimum number of components. The meter features a corrosion resistant, high strength stainless steel body, quick, easy snap-in tube construction and a safety tested operator protection shield.

ABB Purgemasters are ideal for applications such as the purging of control lines and instrument enclosures. Their use is easily extended into fluid sampling, liquid specific gravity, level measurement and similar services.

Specification

Measuring ranges

See measuring range tables on pages 3, 4 and 5

Rangeability

≥10:1

Scale design

% or direct reading scales

Dt/Df ratio scale, millimeters

Accuracy classes (VDE/VDI 3513)

5 in. scale length

1/4 in. & 1/8 in. tube diameter 2.5

1/16 in. tube diameter 6

3 in. scale length

All sizes 10

1 1/2 in. scale length

All sizes 10

Permissible operating temperatures

Buna N O-rings 0 to 120°C

Viton A O-rings 0 to 150°C

Trogamid-tube 0 to 60°C

Types of installation

In-line, front- & rear-panel-mounting

Wall-mounting (regulator only)

Permissible operating pressures (kPa)

Scale length (in.)	Material			
	Stainless steel		Brass	
	Fluid Temperature		Fluid Temperature	
	Max.	Design	Max.	Design
	120 °C	38 °C	95 °C	38 °C
1 1/2 to 3	1800	1800	1400	1800
5 to 10	1800	1800	1400	1800

Materials

Wetted Parts	Standard	Options
Measuring Tube	Borosilicate glass	Trogamid-T (3 in. tube)
Float	1/16 in. Glass (BG) Sapphire (SA) 316 Stainless Steel	Carboloy (CA) Tantalum (TA)
	1/8 in. Glass (BG) Sapphire (SA) 316 Stainless Steel	Carboloy (CA) Tantalum (TA)
	1/4 in. Glass (CD) 316 Stainless Steel	Sapphire (SA) Carboloy (CA) Tantalum (TA)
Float Stop Inlet Outlet	PTFE PTFE	
Fittings	Brass 316 Stainless Steel	Delrin Kynar
O-rings	Buna N Viton A	Ethylenepropylene Kalrez
Tube Adapter	Brass 316 Stainless Steel	W.- no. 1.4401
Needle Valve	316 Stainless Steel	
Return Ball	Nylon	W.- no. 1.4401

Other components

Body	304 Stainless Steel
Operator Production Shield	Polycarbonate

Connections

1/4 in. NPT or G1/4 internal thread, rear-facing horizontal or vertical

Weights

	Without Regulator (kg)	With Regulator (kg)
Model A6131/41	0.45	1.6
Model A6132/42	0.65	1.8
Model A6134/44	0.45	1.6
Model A6135/45	0.45	1.6

Measuring Range Tables

Models A6131/41

Measuring Tube	Float	Water		Air at 0°C 1013mbar		Min. diff. press. bar ^a	Alarm RJ10 = 1 RJ15 = 2	Measuring Tube/Float Combination ^d	
		Tube No.	Float No.	cm ³ /min	l/h				Q _n (cm ³ /min)
FP-1/8-08-P-3/37	BG-18		0.4 to 4.4	0.02 to 0.26	20 to 360*	2 to 21	0.17	–	01
	SA-18		0.5 to 8.5	0.04 to 0.5	20 to 500	2 to 30	0.18	–	02
	SS-18		1 to 19*	0.1 to 1.1	50 to 850*	3 to 50	0.18	1	03
	CA-18		2 to 34	0.1 to 2.0	50 to 1300	5 to 80	0.18	–	04
FP-1/8-20-P-3/37 ^b	BG-18		2 to 28	0.1 to 1.7	100 to 1500	5 to 95*	0.21	–	05
	SA-18		4 to 48*	0.2 to 2.9	200 to 2000	10 to 125	0.21	–	06
	SS-18		5 to 90*	0.4 to 5.4*	200 to 3000*	10 to 180	0.21	1	07
	CA-18		10 to 135	0.5 to 8.0	400 to 4000	20 to 260	0.21	–	08
	TA-14		15 to 145	1 to 8.5	460 to 4600	27 to 270	0.21	–	10
FP-1/4-15-P-3/37 ^b	CD-14		10 to 130	0.5 to 7.5	500 to 6500	20 to 380	0.35	–	01
	SA-14		23 to 230	1.4 to 14	850 to 8500	52 to 520	0.35	–	10
	SS-14		20 to 400	2 to 23.0	1000 to 12500	50 to 750	0.7	2	02
	CA-14		40 to 580	2 to 34.0	1000 to 17000	100 to 1050	0.7	2	03
FP-1/4-20-P-3/37 ^b	CD-14		20 to 220*	0.5 to 13.0*	500 to 9500	40 to 560	0.35	–	04
	SA-14		40 to 400	2 to 22	1000 to 12500	70 to 750	0.35	–	11
	SS-14		40 to 580*	2.0 to 34.0*	1000 to 18000	100 to 1100	0.7	2	05
	CA-14		50 to 850	4 to 50.0	2000 to 25000	100 to 1500	0.7	2	06
FP-1/4-41-G-3/37 ^b	CD-14		40 to 460	2 to 27.0	1000 to 19000	100 to 1150	0.7	–	07
	SA-14		70 to 750	4 to 46	3 to 27000	2 to 1600	0.7	–	12
	SS-14		100 to 1200	5 to 75.0*	2000 to 38000	100 to 2300	0.7	2	08
	CA-14 ^c		100 to 1800	10 to 105	4000 to 54000	200 to 3200	–	2	09

Notes.

- a) Applies only with differential pressure regulator
 - b) Also in Trogamid with % scale tube description .../2D37
 - c) Not available with differential pressure regulator
 - d) For ordering information only
- * Direct reading scales as standard (no extra cost)

Models A6131/41 with Inductive Alarm Sensor (RJ10/RJ15)

Measuring Tube	Float	Water cm ³ /min	Air 0°C 1013mbar cm ³ /min (Q _n)	Minimum Differential Pressure (bar) ^a	Ring Sensor
FP-1/8-08-P-3/37	SS-18	2 to 19	100 to 850	0.18	RJ10-Bi-Y 20593
FP-1/8-20-P-3/37	SS-18	10 to 90	400 to 3200	0.21	
FP-1/4-15-P-3/37	SS-14	40 to 400	1000 to 12500	0.7	RJ15-Bi-Y 20594
	CA-14	80 to 580	2000 to 17000	1.5	
FP-1/4-20-P-3/37	SS-14	80 to 580	2000 to 18000	0.7	
	CA-14	100 to 850	4000 to 25000	1.5	
FP-1/8-41-P-3/37	SS-14	150 to 1200	6000 to 40000	0.7	
	CA-14	200 to 1800	8000 to 54000	Note ^b	

Notes.

- a) In conjunction with differential pressure regulator
- b) Not available with differential pressure regulator

Measuring Range Tables

Models A6132/42

Housing Size	Measuring Tube Size	Max. flow ^a		Measuring Tube No.	Float No.	Alarm RJ10 = 1 RJ15 = 2	Float/ Measuring Tube Combination ^c	
		H ₂ O cm ³ /min	Air (Q _n) 1013mbar 0°C, (cm ³ /min)					
1/4 in.	1/16 in. ^b	0.53	48.1	FP-1/16-10-G-5/81	BG-16		01	
		0.92	80.0	12			02	
		1.61	131.1	16			03	
		2.45	192.5	20			04	
		1.05	73.2	FP-1/16-10-G-5/81	SA-16		05	
	1.58	117.0	12	06				
	3.2	188.6	16	07				
	4.82	270.1	20	08				
	2.46	136.0	FP-1/16-10-G-5/81	SS-16		09		
	4.2	203.5	12			10		
	7.2	319.2	16			11		
	10.3	430.5	20			12		
	4.71	217.9	FP-1/16-10-G-5/81	CA-16		13		
	7.6	307.1	12			14		
	12.3	475.3	16			15		
	17.8	636.2	20			16		
	5.25	234.2	FP-1/16-10-G-5/81	TA-16		17		
	8.4	326.7	12			18		
	13.5	508.5	16			19		
	18.6	678.0	20			20		
	1/8 in.		6.1	373.6	FP-1/8-08-G-5/81	BG-18		01
			13.9	696.3	12			02
			22.6	1046.2	16			03
			31.5	1426.6	20			04
43.7			1885.1	25	05			
10.5		511.3	FP-1/8-08-G-5/81	SA-18		06		
23.0		928.8	12			07		
35.7		1384.7	16			08		
48.5		1857.6	20			09		
64.5		2454.0	25			10		
20.5		804.4	FP-1/8-08-G-5/81	SS-18		11		
39.5		1421.4	12			12		
60.0		2092.8	16			13		
81.0		2788.3	20			14		
107.0		3629.1	25			15		
33.6	1205.7	FP-1/8-08-G-5/81	CA-18		16			
61.2	2089.4	12			17			
90.6	3014.3	16			18			
121.7	3997.8	20			19			
159.7	5136.7	25			20			
36.5	1287.9	FP-1/8-08-G-5/81	TA-18		21			
66.0	2219.0	12			22			
97.5	3202.4	16			23			
130.0	4229.3	20			24			
171.5	5456.3	25			25			
1/4 in.		78	3717	FP-1/4-10-G-5/81	CD-14		01	
		152	6742	16			02	
		206	8928	20			03	
		275	11479	25			04	
		134	5200	FP-1/4-10-G-5/81			SA-14	
	253	9245	16	06				
	337	12231	20	07				
	446	15650	25	08				
	228	7793	FP-1/4-10-G-5/81	SS-14		09		
	415	13672	16			10		
	547	17979	20			11		
	703	22900	25			12		
	346	10967	FP-1/4-10-G-5/81	CA-14		13		
	612	19227	16			14		
	805	25293	20			15		
1036	32200	25	16					
370	11704	FP-1/4-10-G-5/81	TA-14		17			
660	20457	16			18			
860	26703	20			19			
1105	34276	25			20			
1500	45700	FP-1/4-40-G-6/_ _	SS-14	2	21			
2050	64800	FP-1/4-40-G-6/_ _	CA-14	2	22			
2200	67200	FP-1/4-40-G-6/_ _	TA-14	2	23			

Notes.

a) Maximum flow rates for other fluids can be calculated using our handbook 10A9010

b) Not available with differential pressure regulator

c) For ordering information only

Models A6132/42 with Inductive Alarm Sensor (RJ10/RJ15)

Measuring Tube	Float	Max. Flow		Minimum Differential Pressure (bar) ^a	Ring Sensor
		Water cm ³ /min	Air 0°C 1013mbar cm ³ /min (Q _n)		
FP-1/8-08-G-5/81 12 16 20 25	SS-18	20.5 39.5 60.0 81.0 107.0	804.4 1421.4 2092.8 2788.3 3629.1	0.18	RJ10-Bi-Y 20593
FP-1/4-10-G-5/81 16 20 25	SS-14	228 415 547 703	7793 13672 17979 22900	0.7	
FP-1/4-10-G-5/81 16 20 25	CA-14	346 612 805 1036	10967 19227 25293 32200	1.5	RJ15-Bi-Y 20594
FP-1/4-10-G-5/381 16 20 25	TA-14	370 660 860 1105	11704 20457 26703 34276	1.5	
FP-1/4-40-G-6/208 40 40	SS-14 CA-14 TA-14	1512 2180 2329	48384 67580 72168	0.7 ^b	

Notes.

- a) In conjunction with differential pressure regulator
b) Not available with differential pressure regulator

Models A6134/44

Measuring Tube ^b	Float No.	Water cm ³ /min	Air at 0°C 1013mbar Q _n (cm ³ /min)	Min. Required Differential Press bar ^a	Float/ Measuring Tube Combination ^d
Tube No.					
FP-1/16-08-P-1 1/2/19	BG-16 ^c	0.05 to 0.8	5 to 65	-	01
	SA-16 ^c	0.10 to 1.0	5 to 90	-	02
	SS-16 ^c	0.50 to 4.0	15 to 170	-	03
FP-1/16-30-P-1 1/2/19	BG-16	0.5 to 7.0	25 to 400	0.17	04
	SA-16	1.0 to 13.0	50 to 550	0.17	05
	SS-16	2.0 to 22.0	50 to 850	0.17	06
FP-1/8-21-P-1 1/2/19	BG-18	2.5 to 37.5	100 to 2000	0.21	01
	SA-18	5.0 to 60.0	200 to 2600	0.21	02
	SS-18	10 to 120.0	200 to 3800	0.21	03
	CA-18	14 to 180	280 to 5600	0.21	04
FP-5/32-40-P-1 1/2/19	BG-5/32	15 to 190	700 to 8000	0.18	01
	SS-5/32	40 to 450	1200 to 15000	0.18	02
FP-1/4-28-P-1 1/2/19	SA-14	30 to 570	1300 to 19500	0.7	02
	SS-14	50 to 850	2000 to 28000	0.7	01
FP-1/4-41-P-1 1/2/19	SS-14 ^c	100 to 1600	2500 to 45000	-	03
	CA-14 ^c	200 to 2200	5000 to 70000	-	04

Notes.

- a) Applies only with built-in differential pressure regulator
b) Only with % scale. Not available with differential pressure regulator.
c) Not available with differential pressure regulator.
d) For ordering information only.

Overall Dimensions

In-line and Front Panel-mounting (horizontal and vertical connections)

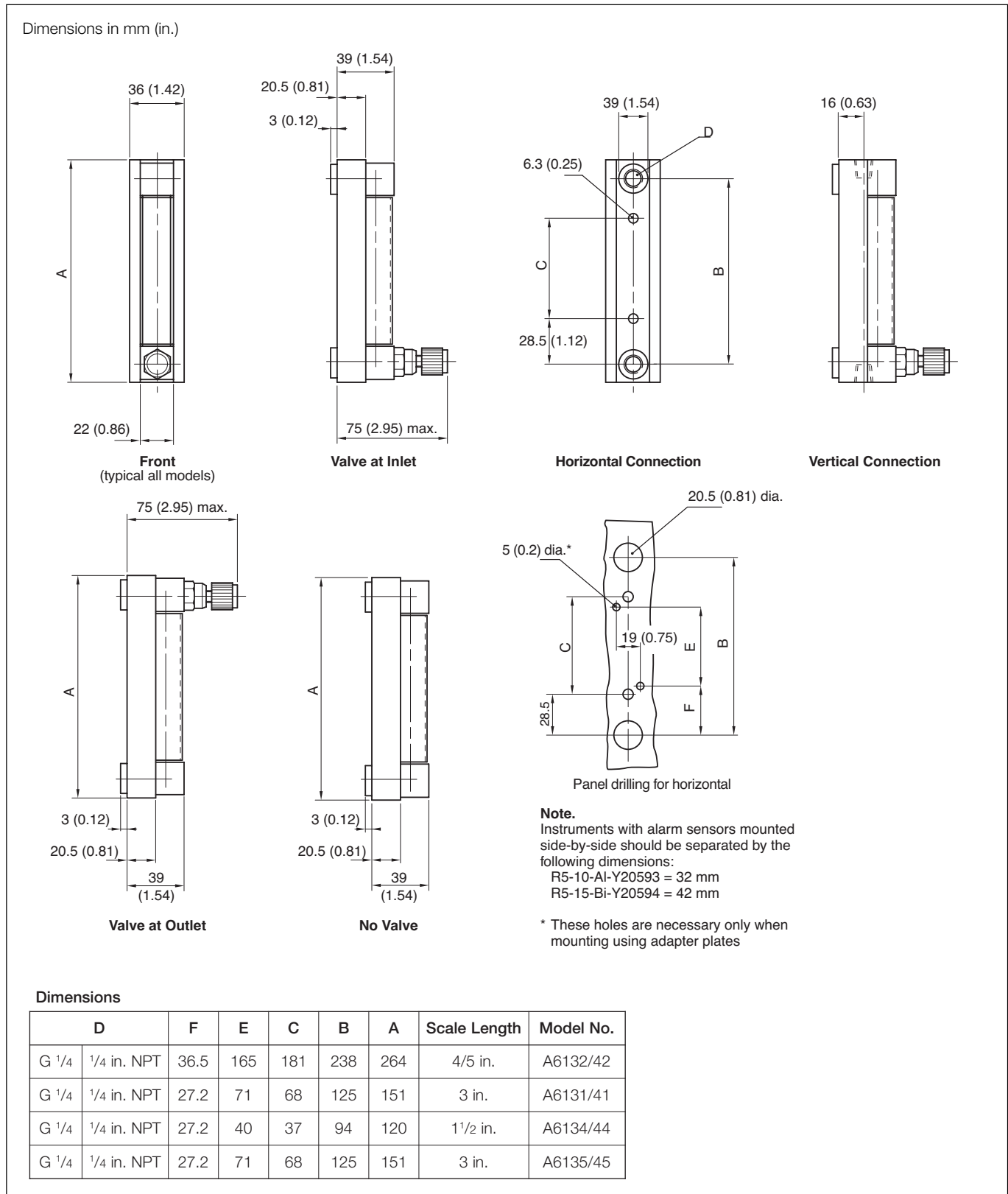

Purgemaster with Regulator

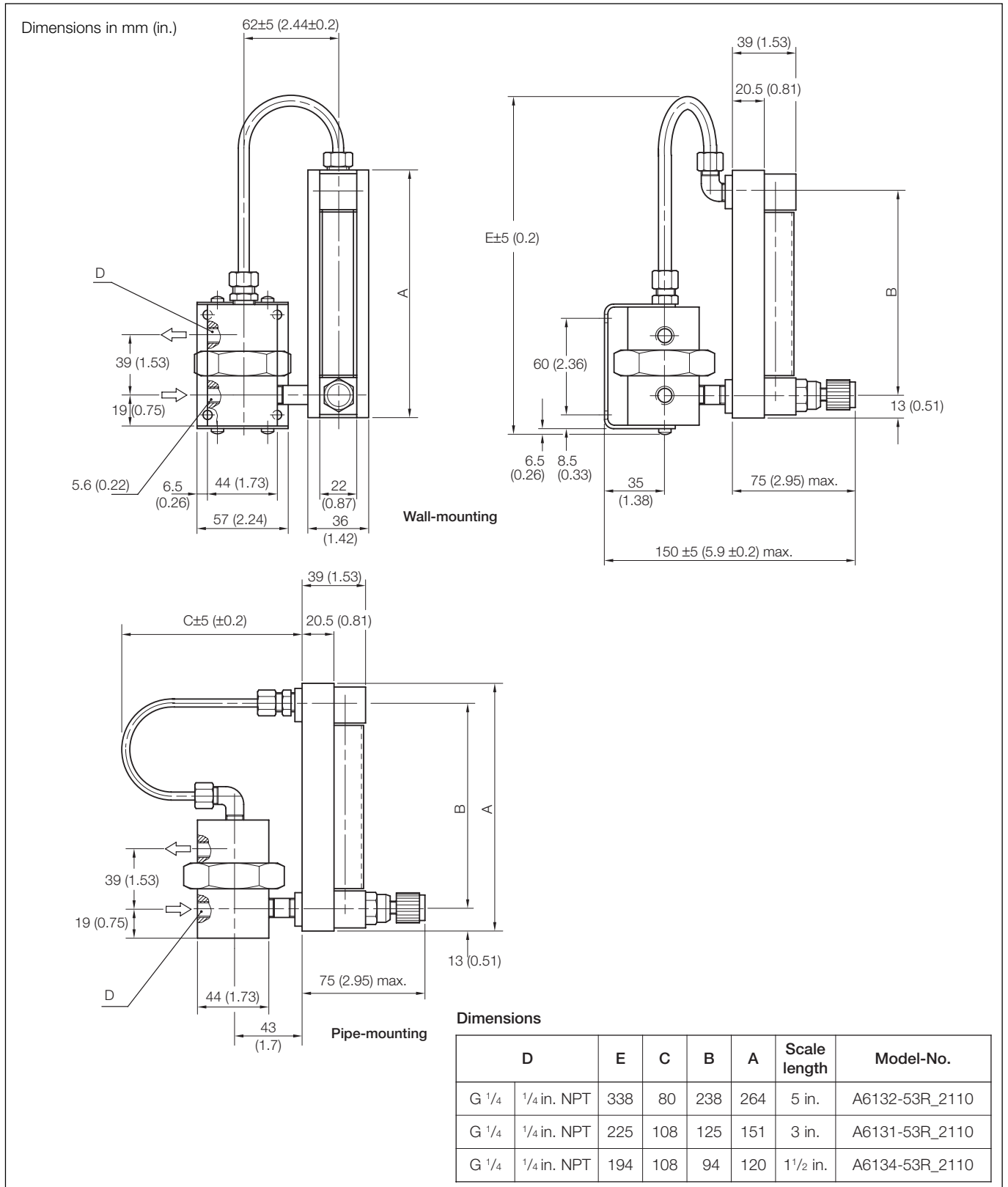

...Overall Dimensions

Panel-mounting (horizontal connections)

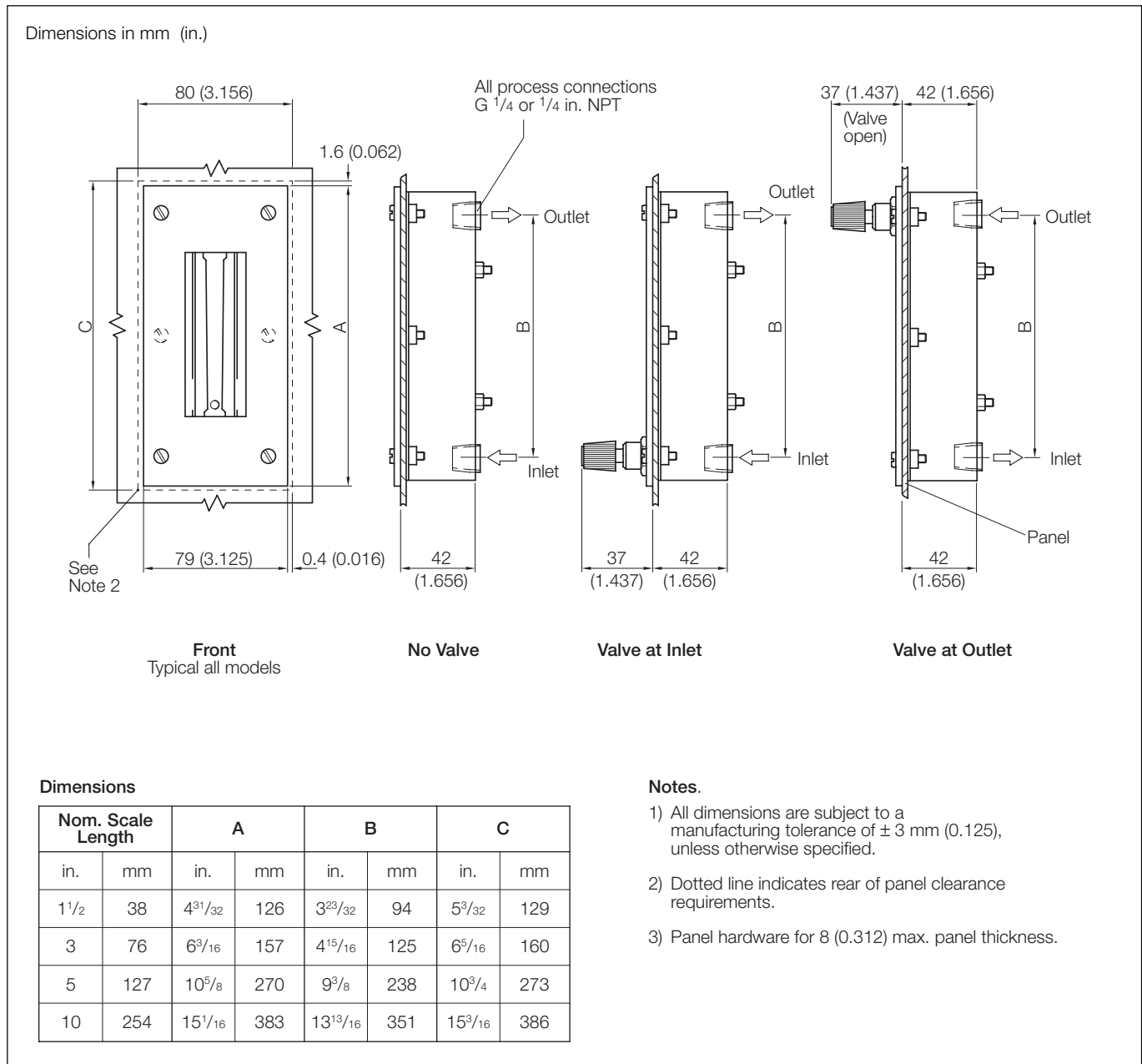

Panel-mounting with Differential Pressure Regulator

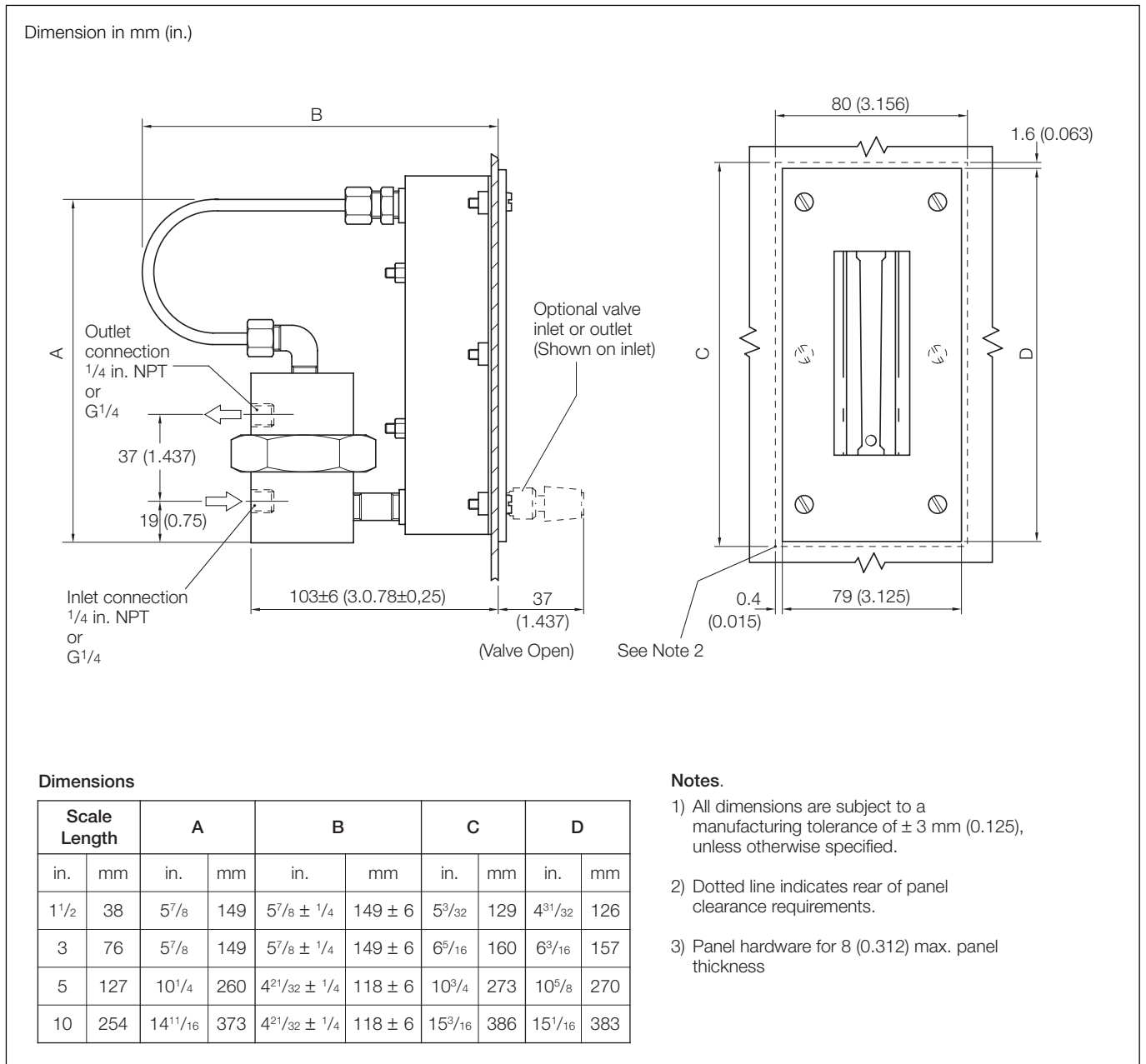

...Overall Dimensions

Panel Cut-out for Panel-mounting

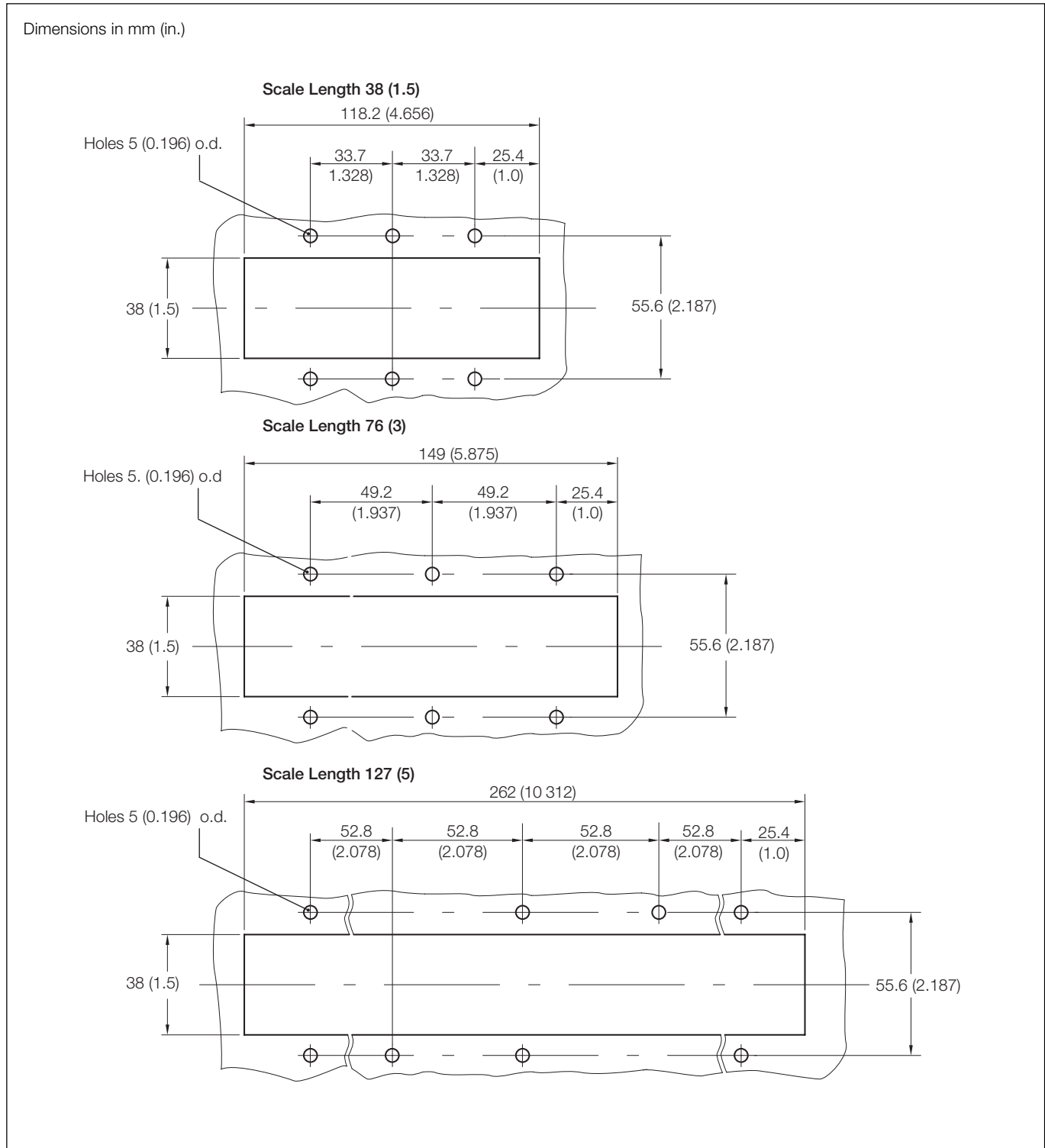

Ordering Information

Model Code	A6	X	X	X	X	X	X	X	X	X	X	X	X	X	X	
Connection																
Horizontal		1														
Vertical		2														
Connection Type																
As regulator			2													
1/4 in. NTP			3													
G 1/4			4													
Tube 6mm			5													
Tube 8mm			6													
Hoses 6mm			7													
Hoses 8mm			8													
Special			9													
Tube Length																
3 in.				1												
5 in.				2												
1 1/2 in.				4												
3 in. Trogamid				5												
Tube Diameter																
1/16 in.						A										
1/8 in.						B										
1/4 in.						C										
5/32 in.						D										
Tube / Float																
None								O	O							
Select from Tables on pages 3, 4 or 5								*	*							
Scale Type																
Without										0						
Direct reading										1						
dt/df ratio										2						
Percent										3						
Standard direct reading										4						
Calibrated										5						
Materials																
Brass / Viton											A					
Brass / Buna											B					
Brass / Ethylenepropylene											C					
Brass / Kalrez											D					
Stainless steel / Viton											I					
Stainless steel / Buna											J					
Stainless steel / Ethylenepropylene											K					
Stainless steel / Kalrez											L					
Special											Z					
Valve																
To be selected at order specification																
Alarm (excluding amplifier)																
Without														A		
Min. alarm														B		
Max. alarm														C		
Min. & max. alarm														D		
Suitable but no sensor														E		
Regulator																
Without															0	
Standard cap 1/4 in. NTP															1	
Standard cap G 1/4															2	
High cap 1/4 in. NTP															3	
High cap G 1/4															4	
Mounting																
In-line																A
Wall																B
Rear panel																C
Front panel																D
Laboratory stand																E
Front panel + adaptor																F
Front panel + end cap																G
Front panel + end cap + adaptor																H
Design level																
																A

Alarm Unit for Purgemaster – 55AN3000 Series

The alarm comprises a ring sensor and associated switching amplifier, available as an accessory, for glass-tube type variable-area flowmeters, type A6131/41 and A6132/42.

Clamped directly to the body, the ring sensor is continuously adjustable across the overall metering range. The ring sensor can be used with all metal-float equipped flowmeters according to the capacity tables.

Principle of Operation

The ring sensor, with a bistable switching action, energizes the relay in the amplifier when the float reaches the trigger level. It remains in that position, even if the float continues to move towards the alarm zone, thus leaving the trigger level. The relay de-energizes as soon as the float crosses the trigger level from the opposite direction and moves back from the alarm zone into the normal operating range. The actual float position – above or below the trigger level – is indicated precisely.

Explosion hazardous operation is possible, since the ring sensor used is an intrinsically safe switch with an intrinsically safe circuit. Flowmeter Model A6131/41 is suitable for use either as a minimum alarm or a maximum alarm, due to its short metering tube. Model A6132/42 is recommended if both alarm operations are required.

Design Features

- Sensor height 14mm, minimizes coverage of the scale
 - Integrated clamp secures device directly to the meter body
- No automatic adjustment during operation is possible



Alarm Unit with Switch Amplifier

Specification – Ring Sensor

Part Nos.

Measuring tube 1/4 in. type RJ15Bi-Y20594

Measuring tube 1/8 in. type RJ10Bi-Y20593

Supply voltage

10V DC

Residual ripple

≤5%

Intrinsic inductance

60μH

Intrinsic capacitance

≤100nF

Operating range

In direction 1 ≤ 2.9mA

In direction 2 ≤ 4.8mA

Permissible resistance of control cable

≤100Ω

Repeatability

1% (T = constant)

Temperature drift

±10%

Permissible ambient temperature

10 to 40°C (50 to 104°F)

Connection cable

LIFYY x 0.14mm²

Cable length

2m (6.5 ft)

3000m (9750 ft) max.

Housing

Black Polycarbonate

Protection type as per EN 60529

IP67

Certificate of conformity

PTB-Nr. Ex-83/2022x

EEx ia IIC T6

EEx ib IIC T6

Weight

40g (1.4oz.) approx.

...Alarm Unit for Purgemaster – 55AN3000 Series

Specification – Switching Amplifier

Switch amplifier depending on ring sensor

Type WE 77/Ex1 Bi

Output

Relay with potential-free changeover contacts.
Switching capacity max. 250VA 4A at 250V AC

Power consumption

1.5VA approx.

Permissible ambient temperature

-20 to +60°C (-4 to 140°F)

Ex protection

Circuit intrinsically safe EEx ia IIC or EEx ib IIC with higher values for inductivity and capacity

Certificate of conformity

PTB No. Ex-79/2043X

Switch amplifier for rail installation or 19 inch insert

On request

Housing

Polyamide

Electrical connection

Terminals

Weight

0.7kg (1.5 lb) approx.

Ordering Information

Model Code	55AN3	X	X	X	X	X
Measuring tube size						
1/8 in.		1				
1/4 in.		2				
Limit signal						
Single alarm				1		
Double alarm				2		
Switch amplifier						
None					1	
WE 77/Ex1 Bi					2	
WE 77/Ex1 Bi *					3	
other on request					9	
Design Level						A
Auxiliary supply for switch amplifier						
None						A
115V, +10%, -15%, 45 to 60Hz						B
230V, +10%, -15%, 45 to 60Hz						C
24V, +10%, -15%, 45 to 60Hz						D
other on request						Z

*For two ring sensors two switch amplifiers are required

Electrical Connections

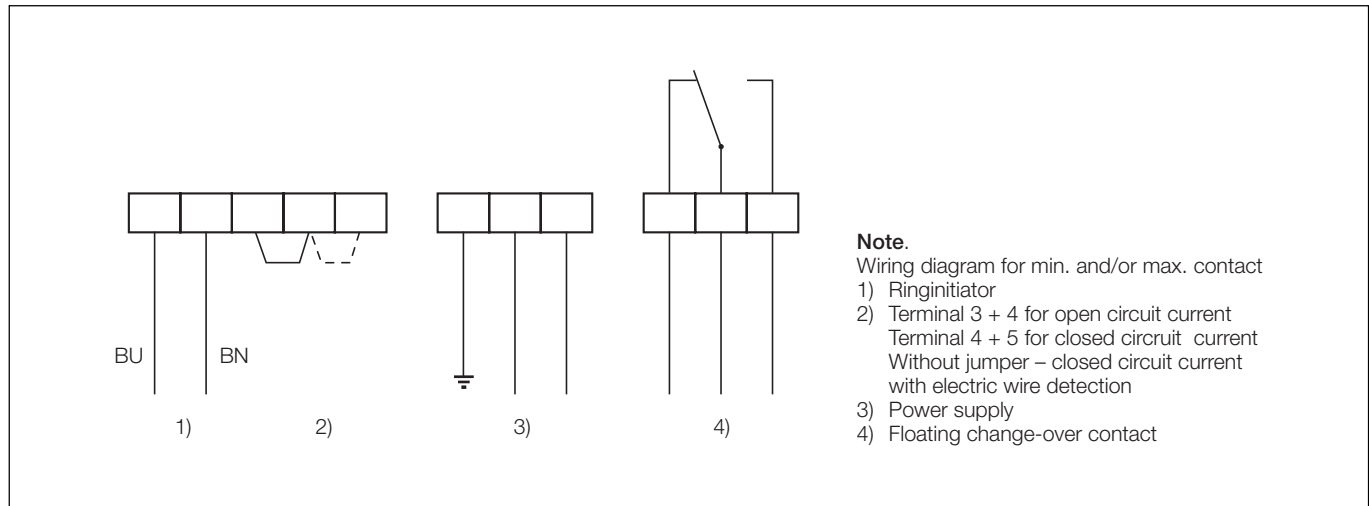

Overall Dimensions

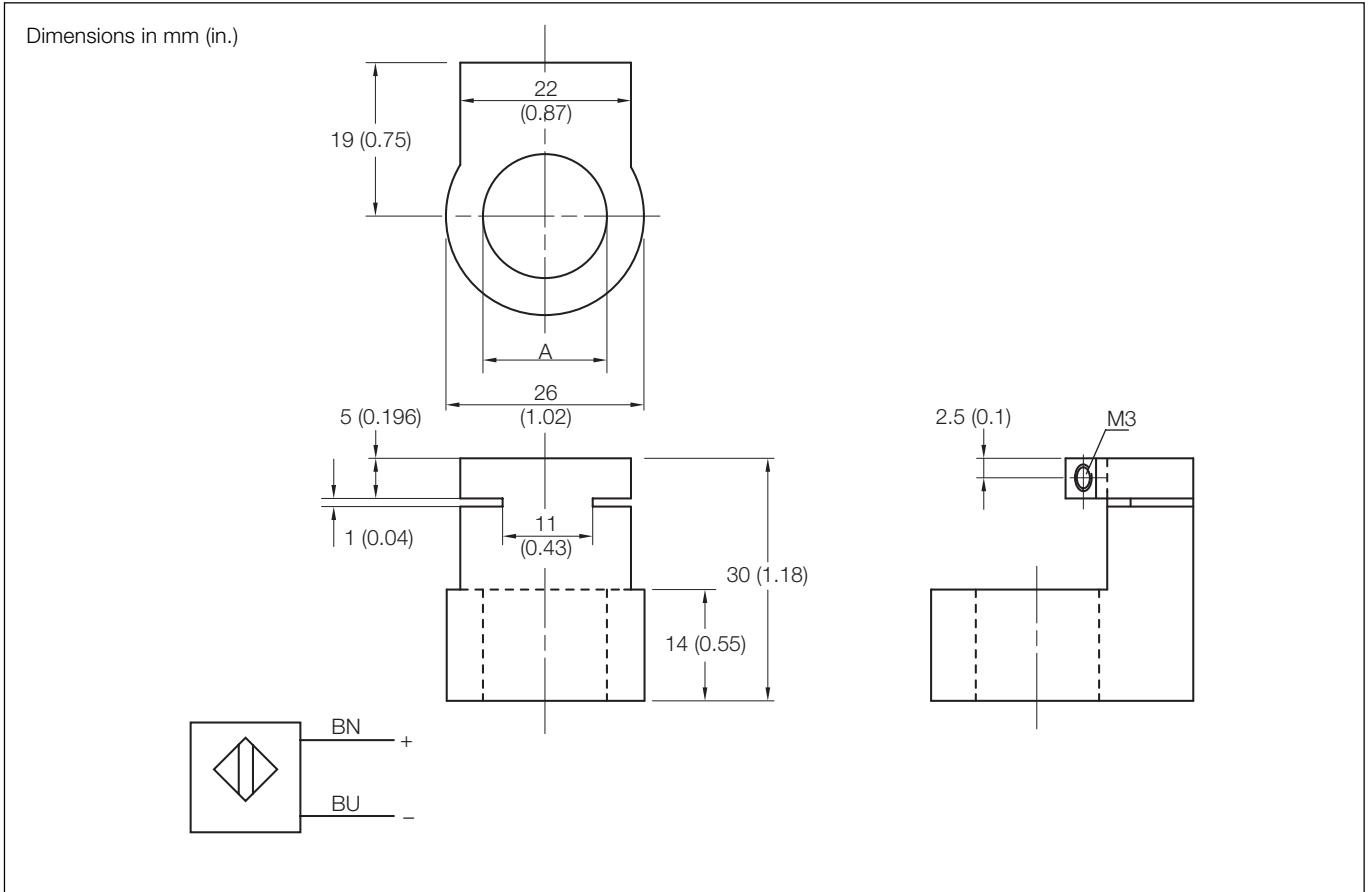

Ring Sensor

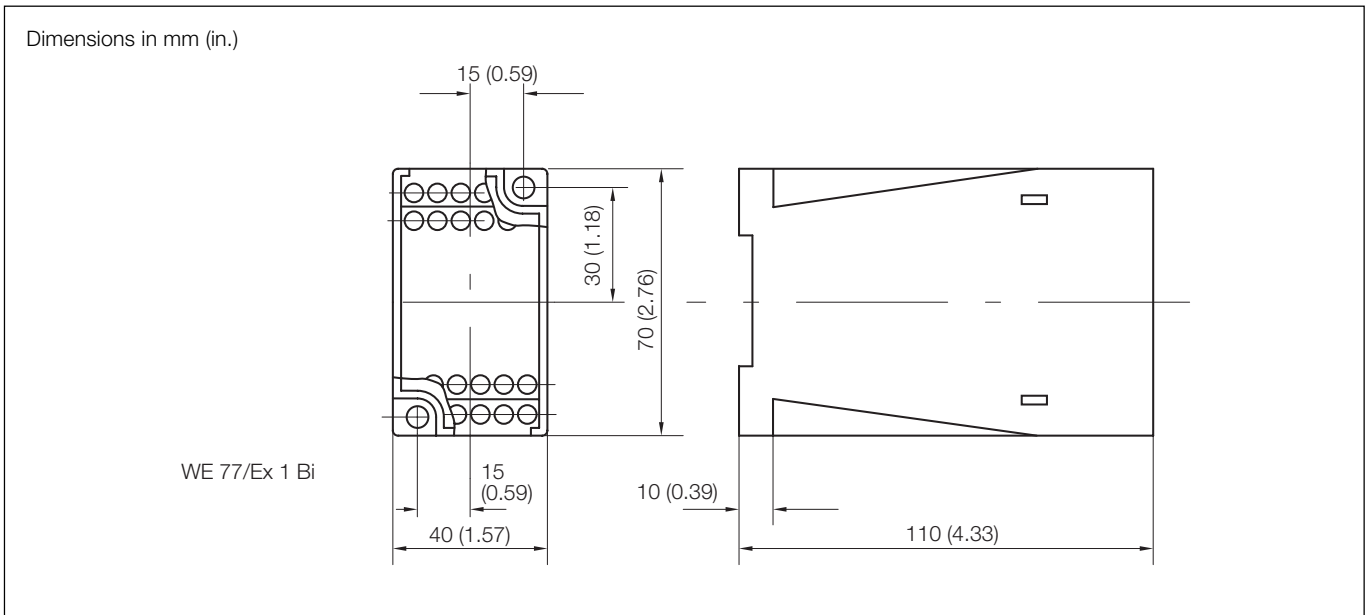

Switch Amplifier

ABB has Sales & Customer Support
expertise in over 100 countries worldwide

www.abb.com

The Company's policy is one of continuous product
improvement and the right is reserved to modify the
information contained herein without notice.

Printed in UK (05.06)

© ABB 2006



ABB Limited

Salterbeck Trading Estate
Workington, Cumbria
CA14 5DS

UK

Tel: +44 (0)1946 830 611

Fax: +44 (0)1946 832 661

ABB Inc.

125E County Line Road
Warminster
PA 18974

USA

Tel: +1 215 674 6000

Fax: +1 215 674 7183