



Zirconia Oxygen Analyser BA 1LT

The BA 1LT oxygen analyser is designed to determine concentrations of residual oxygen content in flue gas of furnaces (max. 350 °C) and to measure the oxygen concentration in air and inert gas mixtures (N₂, CO₂, noble gases).

Its strengths further include use in hard to reach areas and in self-contained systems (ventilation pipes, containers, etc.).

Low energy consumption

Not temperature dependent

4 – 20 mA output signal

No zero drift

High measuring accuracy

Long life

Versatile

No reference gases required

No calibration gases required



Functional principle

The BA 1LT oxygen analyser measures the oxygen partial pressure directly in the gas mixture, the absolute oxygen content. At a constant pressure the measurement value equals the oxygen concentration in Vol.%. The measuring method is based on a dynamic process using two zirconium dioxide discs forming a hermetically sealed chamber.

The entire measuring range is linear.

The sinter protects the sensor element from dust. Available in two styles:

- Full sinter, with enlarged surface, thus faster response time.
- Internal sinter, enhanced draining properties (condensate protection), slower response time.

Since the measuring system monitors the function during operation and alerts to hardware and sensor malfunctions and further features a diagnostic function, it can be operated safely as needed. No second oxygen sensor required for this purpose!

Can be calibrated without reference gas, using atmospheric air.

Measurement values are output via analogue 4-20 mA channel.

Technical Data

Transmitter

Power supply	7-pin plug contact	IP 67 round plug
	Voltage / tolerance	24 V DC \pm 20%
	Output	< 13W
Signal transmission	Up to 300 metre distance	For cables with 1.5 mm ² strands
Connections	Pin 1	24 V DC
	Pin 2	0 V
	Pin 3	Sense
	Pin 4	Test
	Pin 5	K1 analogue output linear 0-10 V or 4-20 mA
	Pin 6	K2 digital I/O impulse and error, electric calibration
	Pin 7	Functional earth
Transmitter ambient temperature	-20° C to +60° C	Please note sunlight!
Permissible humidity	5 to 95% relative humidity	not condensed
Output	4-20 mA, max. burden 500 W	or 0-10 V, impedance 1000 W
Resolution	DAC resolution 12 bit	
Housing	Makrolon 8030 (30% GV), UL94 V-1	red
Housing degree of protection	IP 65	
Housing weight	approx. 150 g	without rod sensor
Housing dimensions	approx. L105 x W42 x H62.3 mm	without rod sensor

Sensor/rod sensor	Full sinter	Internal sinter
Measuring ranges	0.1 – 25 Vol.% oxygen at 1013.25 hPa 1 – 253.31 hPa (O ₂)	0.1 – 25 Vol.% oxygen at 1013.25 hPa 1 – 253.31 hPa (O ₂)
Gas ingress	Via diffusion through full sinter or internal sinter	Via diffusion through full sinter or internal sinter
Heat-up time	approx. 10 min (at a flow rate of 0 m/s)	approx. 10 min (at a flow rate of 0 m/s)
Accuracy K1	±2% MBE at 25 °C and 1013.25 hPa	±2% MBE at 25 °C and 1013.25 hPa
Reproducibility K1	±1% MBE at 25 °C and 1013.25 hPa	±1% MBE at 25 °C and 1013.25 hPa
Temperature	up to +350°C	up to +350°C
Flue gas speed	up to 5 m/s	up to 5 m/s
Sensor degree of protection	IP40	IP40
Response times		
T20	10 s	15 s
T60	12 s	26 s
T90	18 s	50 s
T95	25 s	60 s
Probe length L1 (±4 mm)		
200 (350 °C)	197 mm	211.5 mm
Diameter	approx. 12 mm	approx. 12 mm
Diameter	approx. 12 mm	approx. 12 mm
Material	Tube stainless steel 1.4301 Sinter stainless steel 1.4404	Tube stainless steel 1.4301 Sinter stainless steel 1.4404

Ordering Instructions

Item no.	Description
55015001	BA 1LT O ₂ Analyser, 24V DC, L: 220mm, internal sinter
55015002	BA 1LT O ₂ Analyser, 24V DC, L: 220mm, full sinter
55015001-SEN	Replacement probe for BA 1LT O ₂ analyser, L: 220mm, internal sinter
55015002-SEN	Replacement probe for BA 1LT O ₂ analyser, L: 220mm, full sinter

Drawing

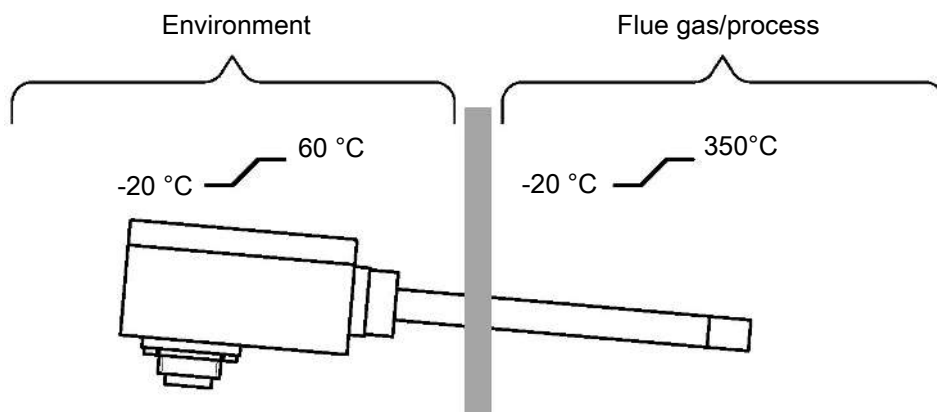

Fig. 1: Installation BA 1LT