



PSS-10/1

Portable Gas Conditioning Unit series PSS®

Version PSS-10/1 for 480 NI/hr gas flow rate

Special Features

- Low maintenance and self-monitoring
- Outlet dew point adjustable from +2 °C to +15 °C
- Dew point stability $\pm 0,1$ °C
- Operational in 20 minutes
- Compact construction
- Light weight
- Optimum reliability
- Jet Stream heat exchangers in 3 standard materials
- Universal equipment possible

Application

The portable gas conditioning unit PSS-10/1 is designed to carry out precise gas analyses at different locations. The entire gas conditioning unit is housed in a robust aluminium-frame case to enable you to carry out your gas analysis rapidly, safely and with little maintenance work. The PSS-10/1 gas conditioning unit is suitable for variable, discontinuous use as for continuous operation. The components built into the PSS-10/1 gas conditioning unit are envisaged for "standard use". Obviously our extensive Product Range provides additional components.

Description

The M&C PSS-10/1 gas conditioning unit is fitted with an two stage ECP20-2 gas cooler which cools the sample gas to a constant +5°C irrespective of the ambient temperature. As soon as the operating temperature of <+8°C is reached after start up, the gas pump N9KPE is switched on automatically by the gas cooler status contact. The SR 25.1 peristaltic pumps ensures a constant condensate drain, making long-term measurement possible without problems. The corresponding particle filtration is carried out by the FP-2T micron filter. This all makes the portable gas conditioning unit a complete gas conditioning system for most gas-analysis devices.

Flow scheme PSS-10/1

- 1 Gas sample probe
- 2 Sample line, 3 m Viton hose
- 3 Gas cooler ECP 20-2
- 4 Fine filter FP-2T, filter porosity 2 μm
- 5 Gas diaphragm pump N9KPE
- 6 optional flowmeter FM 40
- 7 Pre-filter PF2
- 8 Peristaltic pump SR25.1

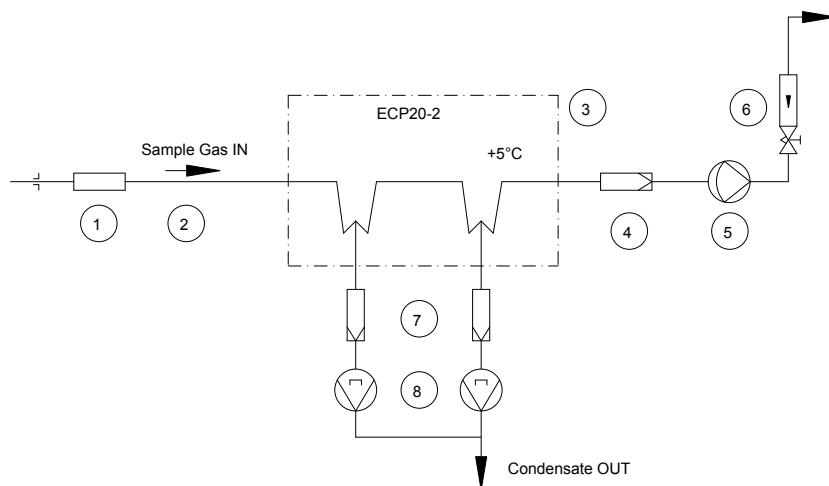

Dimensions

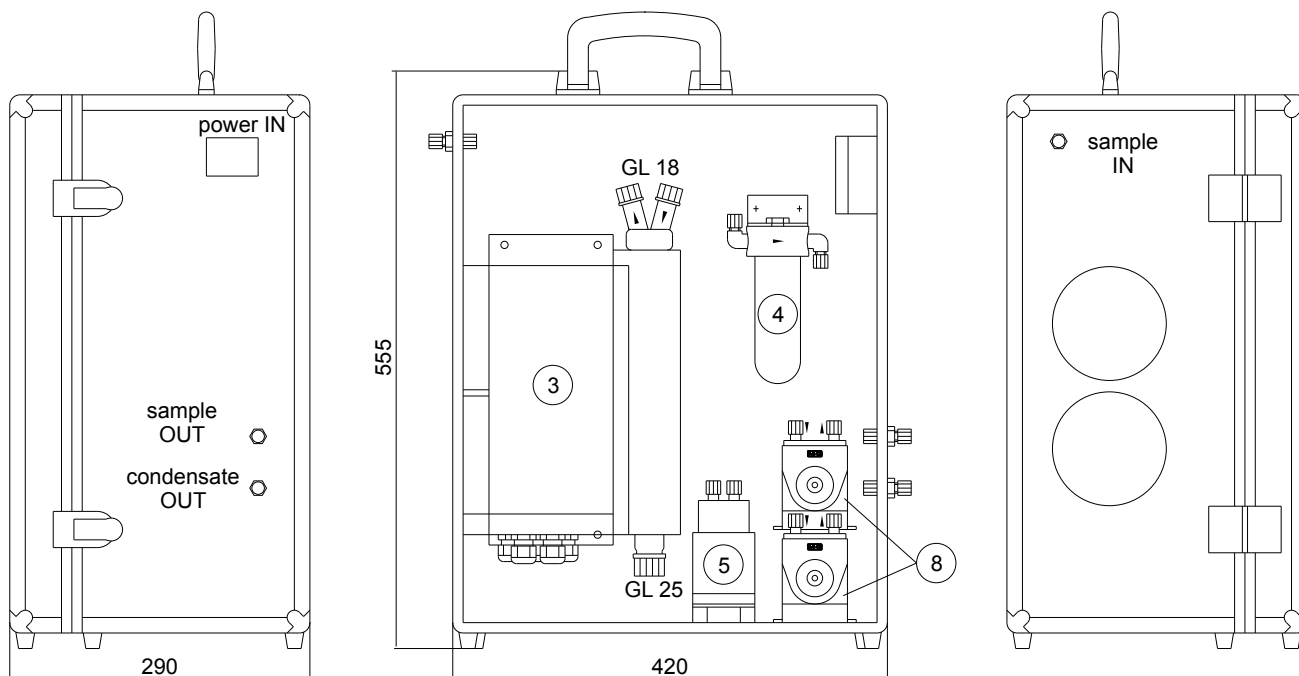

Dimensions in mm

Technical Data

Gas Conditioning Unit series PSS®	version PSS-10/1
Part No. for 230V 50Hz version	01G5000
Part No. for 115V 60Hz version	01G5000a
Sample outlet dew point	range of adjustment: +2 °C +15 °C, factory setting: +5 °C
Dew point stability	at constant conditions < ±0,1 °C
Sample inlet temperature	**max. 80 °C optional: **max.180 °C with stainless steel bulkhead union
Sample inlet dew point	**max.+80 °C
Gas flow rate	**max. 480 NI/hr
Ambient temperature	**+5 °C up to +40 °C
Storage temperature	-25 °C up to +65 °C
Pressure	0,7 bar up to 1,4 bar abs.
Total cooling capacity	**max. 80 kJ/hr
Number of gas inlets	1
Number of gas outlets	1 optional: max. 4
Medium connections	tube connection 4/6 mm
Material of sample contacting parts	stainless steel, glass, PVDF, Viton®, Novoprene®
Ready for operation	approx. 10 min.
Power supply	230V 50Hz or 115V 60Hz
Power consumption	max. 350VA; with option temperature controller and heated sample line 230V: max.1730VA 115V:max. 1040VA
Fuse protection	4A t, 5x 20 mm, with option temperature controller: 6,3A t
Electrical connection	Cold appliance plug with 2 m of cable
Case protection	IP20 (DIN 40050. IEC 529)
Housing	portable aluminium-frame case
Housing dimensions	555 mm x 460 mm x 290 mm (H x W x D)
Electrical equipment standard	EN61010
Weight	approx. 24 kg

Options	Type	Part No.
Further sample gas outlet	Parallel sample gas outlet, tubing via T-piece on lateral PVDF bulkhead fitting, DN4/6, max. 4 pieces	01G9065
Flowmeter, max. 4 pieces	FM40 7-70 l/hr air, mounted in sample gas outlet FM40 15-150 l/hr air, mounted in sample gas outlet FM40 25-250 l/hr air, mounted in sample gas outlet FM40 50-500 l/hr air, mounted in sample gas outlet	01G9070 01G9075 01G9080 01G9085
Fittings out of PVDF	Fittings out of PVDF instead of PP and 3m FPM sample tube DN4/6	01G9025
Sample tube	Sample tube out of Kanthal® ø 6 mm, length 1 m, sampling temperature max. 1300 °C	01G9030
Liquid alarm	Liquid alarm LA 1/1.4, consisting of: liquid alarm sensor LA1, controller LA1.4, filter glass F120G-D with GL connection incl. moutage/wiring. In case of condensate inrush, the sample gas pump is automatically switched of.	01G9035
3-way ball valve	3L/PV-1 for switching over from test gas to sample gas, in the inlet of the sample gas conditioning unit, mounted with mounting brackets, fitting PVDF	01G9046
5-way ball valve	5L/PV-1 for switching over from test gas to sample gas, in the inlet of the sample gas conditioning unit, mounted with mounting brackets, fitting PVDF	01G9045
Electronic temperature controller for max. 12 m heated sample line 100W/m	701 control range 0-200 °C, inlet PT100, power 230V 50Hz, Contact capacity 250V AC max. 4A, completely mounted incl. 7-pin plug 10A	01G9055
Electronic temperature controller for max. 12 m heated sample line 100W/m	701 control range 0-200 °C, inlet PT100, power 115V 60Hz, Contact capacity 250V AC max. 4A, completely mounted incl. 7-pin plug 10A	01G9055a
Connecting adapter DN4/6 for heated sample line	PSS-10 connecting adapter with bending protection for rigid moutage of heated sample line with interchangeable PTFE tube DN4/6, consisting of stiffening plate, Swagelok fitting with 4mm cartridge, material: SS316Ti.	01G9062
Connecting adapter DN6/8 for heated sample line	PSS-10 connecting adapter with bending protection for rigid moutage of heated sample line with interchangeable PTFE tube DN6/8, consisting of stiffening Swagelok fitting with 4mm cartridge, material: SS316Ti.	01G9063

PP = Polypropylene

PTFE = Polytetrafluoroethylene (Teflon®)

PVDF = Polyvinylidenfluoride

** Maximum values in technical data's must be rated in consideration of total cooling capacity at 25 °C ambient temperature and 5 °C outlet dew point.

Other versions on request.