



MP47

Analytical Diaphragm Pump Series MP®



Version MP47, MP47-Z, MP47../EX

Special Features

- Corrosion resistant
- 100% lubricant free
- Gas tight
- Maintenance free
- Diaphragm breakage monitoring possible
- Long service life
- Explosion proof version according to ATEX for zone 1

Application

This diaphragm pump MP47.. is suitable for corrosive gases. It is constructed especially for problems in the analysis technique.

Description

The pump MP47 has a PTFE-head. All sample contacting parts are made of PTFE. The pump works absolutely lubricant free, so gases remain analytically unchanged. Due to a special diaphragm and valve system, the pump operates maintenance-free.

The MP47... is available in 230V or 115V and in execution according to ATEX  II2G for applications in hazardous areas as well.

The standard MP47 is designed for normal applications at a maximum gas flow of 6l/min. Up to flow rates of 17l/min we recommend the type MP47-Z.

With the option ../R a needle valve is build into the pump-head to adjust the flow rate.

– See data sheet 10.2. –

M&C provides for the series MP47... as option a diaphragm breakage monitoring MP47../D. It is equipped with a special double-membrane safety system.

– See data sheet 10.3. –

Dimensions

Pump MP47 / MP47-Z

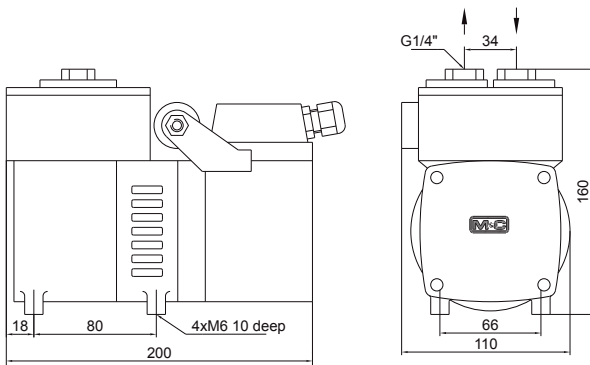

Pump MP47-EX with an ex-motor

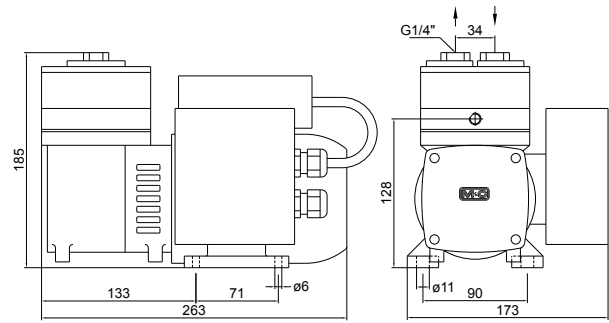

Dimensions in mm

Performance characteristics MP47 / MP47-Z

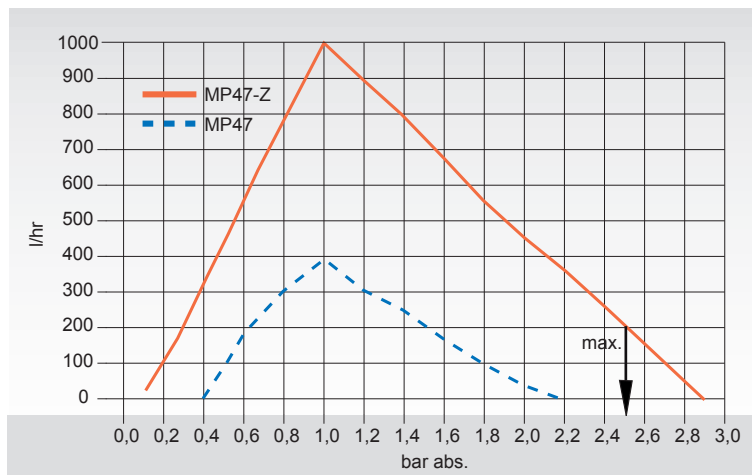

Working pressure for MP47-Z is max. 2,5bar abs.

Technical Data

Diaphragm pump	MP47	MP47-EX*	MP47-Z	MP47-Z/EX *
Part number 230V 50Hz	02 P 1000	02 P 1200	02 P 1100	02 P 1250
Part number 115V 60Hz	02 P 1000a	02 P 1200a	02 P 1100a	02 P 1250a
Degree of protection	IP 20 EN 60529	II 2G EEx e, q II B T3 IP 44 EN 60529	IP 20 EN 60529	II 2G EEx e, q II B T3 IP 44 EN 60529
Capacity max.	6,0 l/min without pressure 0,85 / 1,25 bar abs. on suction / pressure: 2,5 l/min		17 l/min without pressure	
Operating pressure	0,4 to 2,2 bar abs.		0,1 to 2,5 bar abs.	
Sample temperature	-30 to +80 °C			
Ambient temperature	-10 to +40 °C			
Storage temperature	-15 to +60 °C			
Power consumption	110W	70W	110W	70W
Current consumption 230V/115V	0,75A/1,7A	0,96A/1,91A	0,75A/1,7A	0,96A/1,91A
Gas connections	G1/4" i DIN ISO 228/1			
Material of sample contacting parts	PTFE			
Operation mode	100% continuous duty, start of the pump only without pressure			
Weight	4,4 Kg	5,5 Kg	4,4 Kg	5,5 Kg

* The pumps are intended for delivering air as well as gases, vapours and mists in explosion groups II A and II B, temperature class T4
EEx e II T3 Motor 115V 60Hz or 230V 50Hz standard
EEx e II T4 Motor 230/380V 50Hz on request