

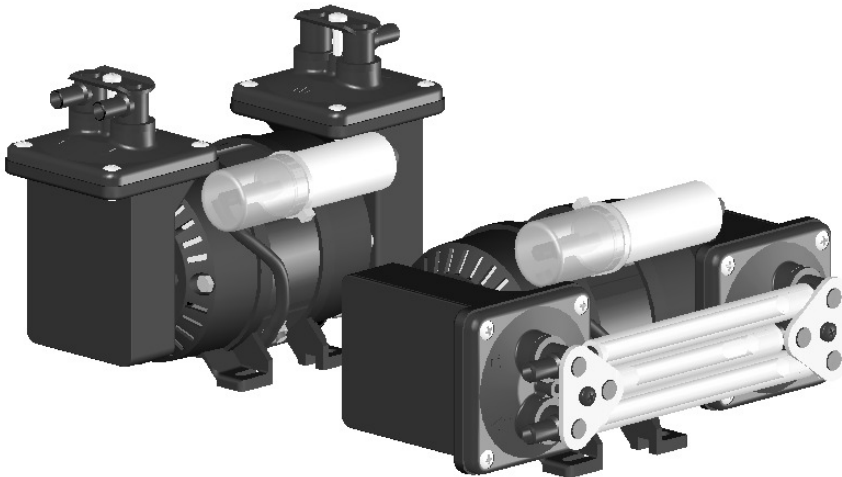

## Oil-Free Diaphragm Pump

# D15



<b>Max Flow</b>
32 l/min
<b>Max Pressure</b>
2.0 Bar
<b>Max Vacuum</b>
50 mbar (abs)

### Double Ended Pump

Heads can be connected:  
 In Series - for maximum vacuum performance  
 In Parallel - for maximum flow performance  
 Un-connected - for independent connection

### Triple Valve DE Pump

Heads are connected to optimize vacuum and flow performance in a compact package

### Pump Materials\*

Component	Material	
	Standard	Triple Valve
Head	Nylon	Nylon
Diaphragm	EPDM	EPDM
Valves	Nitrile	Viton
O-Rings	Nitrile	Viton
Cages	Stainless Steel	Stainless Steel
Clamp plate	Stainless Steel	Stainless Steel
Screw	Stainless Steel	Stainless Steel

### Motor Type\*

220-240V 50-60Hz  
 Permanent Capacitor

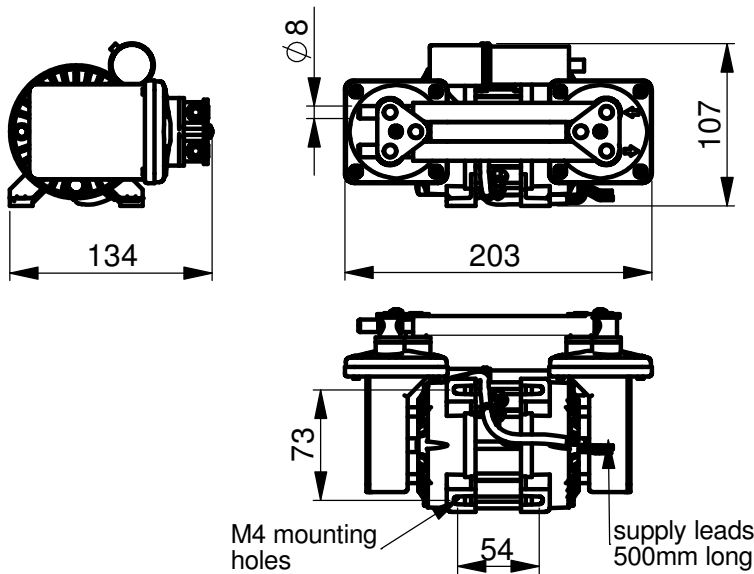

D15 Triple Valve

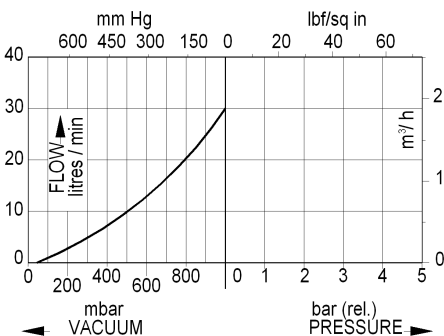

D15 Double End

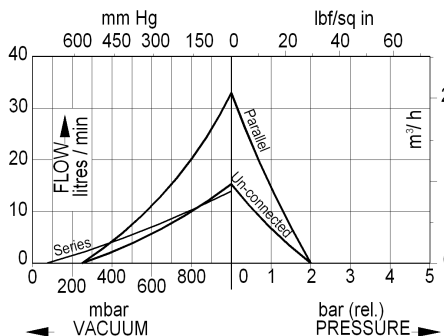

### Performance\*

Model	max free flow l/min	max vacuum mbar (abs)	max pressure bar
Un-connected	15	250	2.0
Series	14	80	n/a
Parallel	32	250	2.0
Triple Valve	30	50	n/a

\*options available, contact the sales office with your requirements