



## Sample Gas Filter AGF-T-30

Even if the particular contaminant has already been removed at the extraction point through effective particle filtration inside the gas sampling probe, in long or branched sample gas line there is a risk of secondary contamination. Additional filters are therefore often installed at the point where the sample gas enters the analysis system and also before delicate system components. The filter housings must be made of corrosion-resistant, non-absorbent materials, easy to install and easy to maintain. They should further be compatible with various filter elements.

The AGF-T- 30 series has a PTFE and glass housing. The filter head has an additional connection for installing a moisture detector. A variety of materials is available based on the application.

Full PTFE housing top

Maximum chemical resistance, for use in highly aggressive mediums

Filter fineness of 2 µm or 25 µm with sintered PTFE elements

No absorption of trace gasses

Quick response time in systems due to low dead volume

Variable wall mount



Dimensions

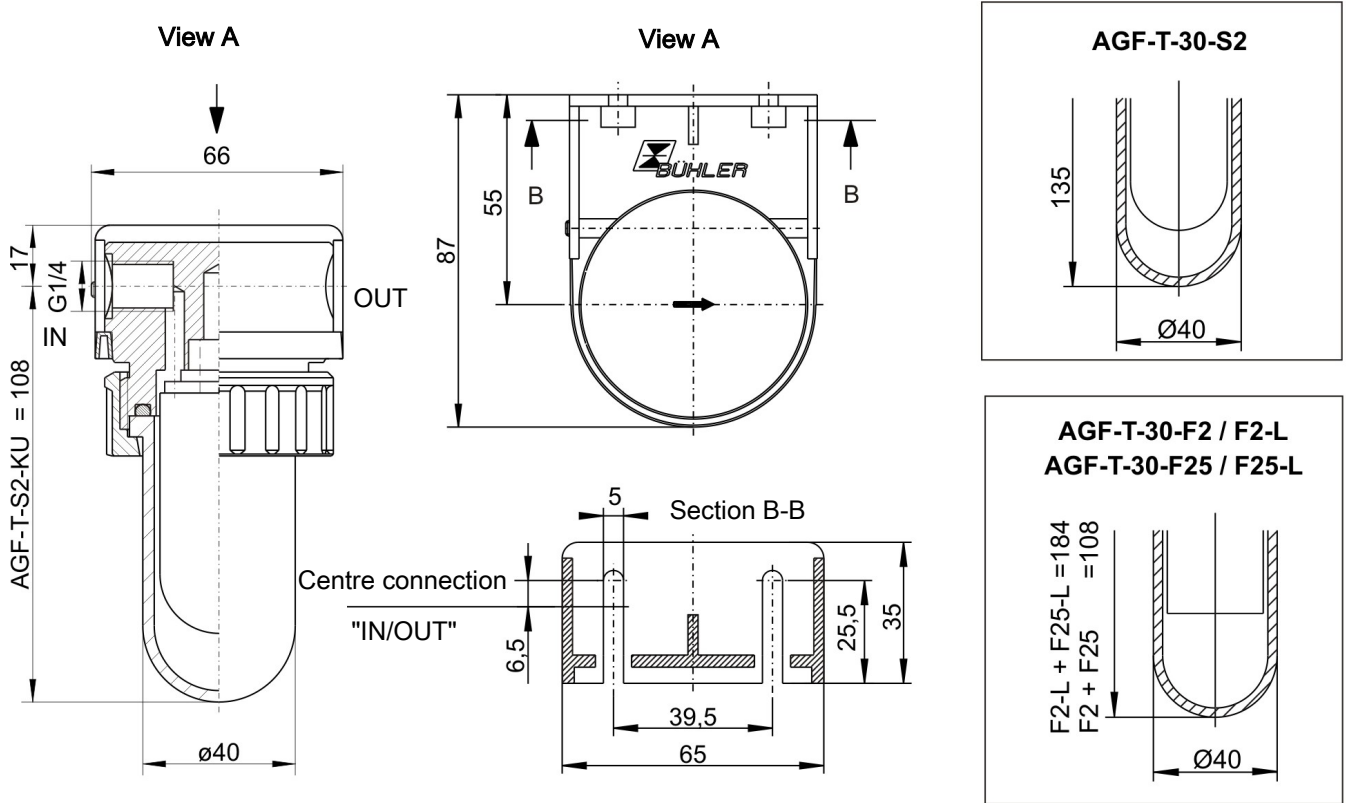

**Use in explosive areas (additional notices):**

The filter meets the fundamental safety requirements of Directive 2014/34/EU and is suitable for use in Category 2G, Explosion class IIB areas. The filter is not marked, as it does not have an innate ignition source and Directive 2014/34/EU therefore does not apply.

Flammable gases, explosion class IIB or IIC, which could occasionally be explosive during normal operation may be conveyed through the filter.

**Be sure to observe the instructions in the respective operating instructions!**

**Ambient temperature range for Ex area applications:**  $-5\text{ °C} \leq T_{\text{amb}} \leq 60\text{ °C}$ .

Technical Data

AGF-T-30 Fine mesh filter

Material – Filter head	PVDF
Material – Filter cover	Glass
Material – Gasket	Viton, PTFE shrouded
Operating pressure max.	4 bar
Operating temperature max.	100 °C

Ordering instructions

Filter\*

AGF-T-	30-S2	30-S2-KU	30-F2	30-F2-L	30-F25	30-F25-L
Filter fineness	2 µm	2 µm	2 µm	2 µm	25 µm	25 µm
Item no.	4151399	4151499	4151799	4151099	4151199	4151299
Element	S2	S2KU	F2	F2-L	F25	F25-L
Dead volume	57 ml	50 ml	57 ml	108 ml	57 ml	108 ml
Weight approx.	0.41 kg	0.35 kg	0.35 kg	0.43 kg	0.35 kg	0.43 kg

\* one filter element is included with delivery.

## Filter elements

Item no.	Model	Filter element	Material	Filter fineness	Filter surface	VE	Ex application
41 01 00 10	S2	Sleeve	Fibreglass	2 µm	80 cm <sup>2</sup>	5 count	IIC
41 01 00 2	S2	Sleeve	Fibreglass	2 µm	80 cm <sup>2</sup>	25 count	IIC
41 01 01 40	S2-KU	Sleeve	Fibreglass	2 µm	61 cm <sup>2</sup>	5 count	IIC
41 01 01 50	S2-KU	Sleeve	Fibreglass	2 µm	61 cm <sup>2</sup>	25 count	IIC
41 03 00 50	F2	Sintered PTFE	PTFE	2 µm	60 cm <sup>2</sup>	5 count	IIB
41 02 01 30	F25	Sintered PTFE	PTFE	25 µm	60 cm <sup>2</sup>	5 count	IIB
41 02 00 50	F2-L	Sintered PTFE	PTFE	2 µm	125 cm <sup>2</sup>	2 count	IIB
41 01 01 20	F25-L	Sintered PTFE	PTFE	25 µm	125 cm <sup>2</sup>	2 count	IIB