



Panel-Filter AGF-FE

Especially in emission control via portal analysis systems the sample gas cannot always be extracted without particle contamination. The necessary conditioning systems must be compact and lightweight and therefore require small and light system components.

We offer special filter housings for these applications and for installation into a standard 19" rack.

The AGF-FE filters screw into the front panel with sample gas connections at the back. They are available in a variety of material combinations.

Front panel installation

Easy installation

Large filter surface

Easy element replacement

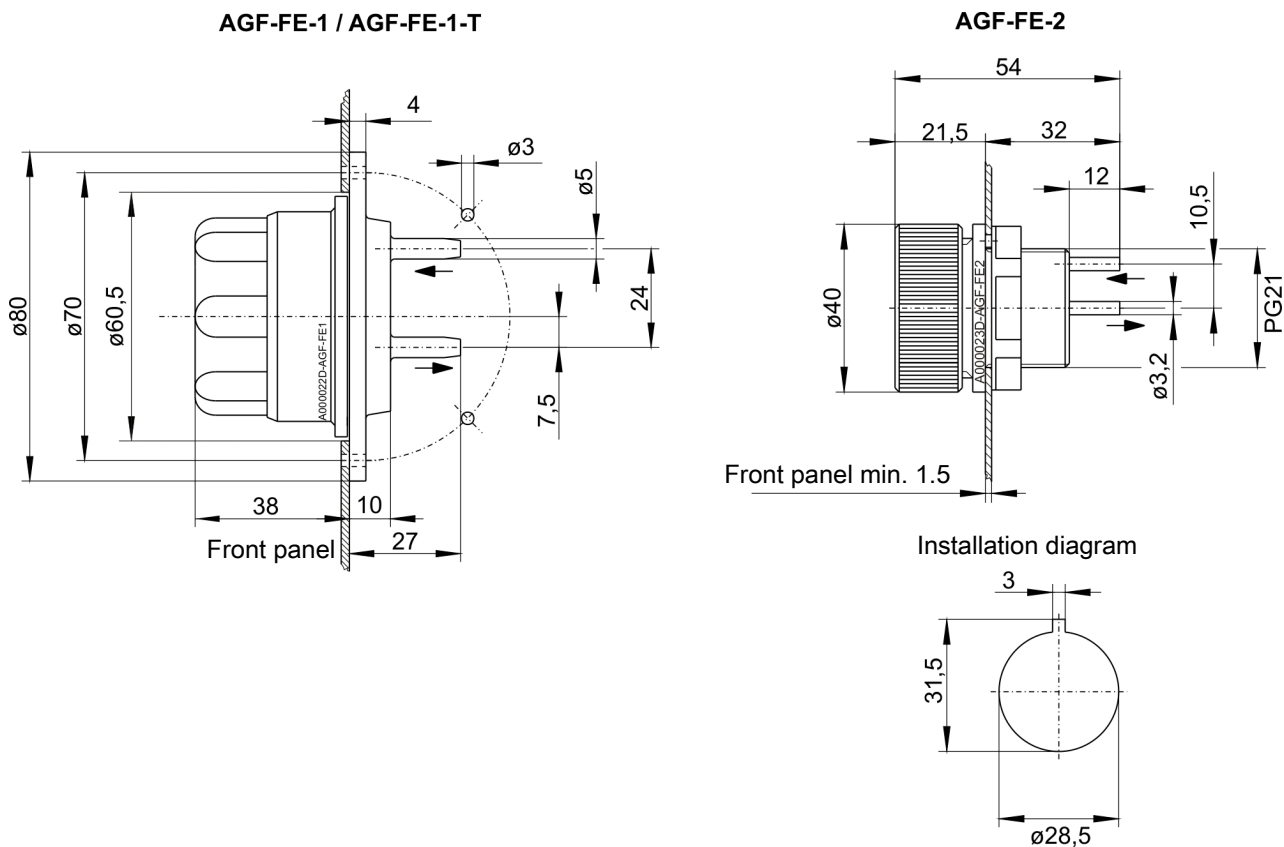

Dimensions

Technical Data

Built-in filter	AGF-FE-1	AGF-FE-1-T	AGF-FE-2
Filter surface	40 cm ²	40 cm ²	13 cm ²
Filter fineness	2 μm	2 μm	8 μm
Dead volume	25 ml	25 ml	6 ml
Material - filter housing	PC	PC	PVDF / 1.4571
Material - gasket	Viton	Viton	Viton
Material - filter element	Fibreglass / epoxy resin	PTFE	Fibreglass / epoxy resin
Connections	DN 4/6	DN 4/6	DN 2/4
Operating pressure max.	2 bar	2 bar	2 bar
Medium temperature	max. +80 °C	max. +80 °C	max. +80 °C

Ordering instructions
Filter*

Item no.	Model
41 15 9991	AGF-FE-1
41 15 8991	AGF-FE-1-T
41 15 099	AGF-FE-2
90 09 162	O-ring for model FE-E1 / FE-1-T
41 28 011	O-ring for model FE-E2

* one filter element is included with delivery.

Filter elements

Item no.	Model	for filter model	VE
41 15 00 10	FE-E1	AGF-FE-1	5 count
41 15 00 90	FE-1-T	AGF-FE-1-T	5 count
41 15 09 910	FE-E2	AGF-FE-2	5 count