

AT
SERIES
MecALAC

EN



AT
SERIES
MecALAC





AT

A TELESCOPIC WHEEL LOADER

“For decades, Mecalac has been developing and producing high-quality and innovative wheel loaders at the Búdelsdorf site in Northern Germany. With our articulated loaders, four-wheel steered front loaders and four-wheel steered swing loaders, we are the only manufacturer to offer all concepts for compact loaders. At Mecalac you can choose the best suitable solution for your application.

On the platform of our front loaders with four-wheel steering, the AT900 and AT1050 are telescopic loaders with an excellent stability. For this version, Mecalac has chosen a rigid chassis. In connection with the four steering wheels who assure exceptional manoeuvrability, the telescopic loaders keep their “wheels on the ground” and offer high performance – even in the most confined work sites.”

Henri Marchetta,
Chairman Groupe Mecalac S.A.S.



AT900 AND AT1050 IN 4 POINTS

**A TECHNOLOGY
MADE FOR THE
TOUGHEST WORK
REQUIREMENTS →**

The telescopic AT wheel loaders are frequently being used in material handling. With this in mind once again Mecalac has chosen the most adapted technology for the needs of its customers: parallel kinematics, a rigid chassis with four wheel steering, a cabin with two doors, and a hydraulic quick-coupler.



A close-up photograph of a yellow hydraulic arm from a Mecalac excavator. The arm is positioned horizontally and features the brand name 'Mecalac' in a bold, black, sans-serif font. A white plus sign is centered on the yellow surface below the text. The background is a solid, dark grey color. Various mechanical components, including hoses, cables, and a hydraulic cylinder, are visible on the arm.

Mecalac

+

AT



AT

THE | P | KINEMATICS

AN OPTIMISED LOADING HEIGHT AND REACH THANKS TO THE TELESCOPIC BOOM

The telescopic boom of the wheel loaders AT900 and AT1050 has changed. The two machines are from now on equipped with a telescopic boom with parallel kinematics. The P-Kinematics offer superior performances as well as a number of advantages for the user.

The new P-Kinematics guarantee **an absolute parallel guidance** of the loading forks and at the same time allow for an exceptional breakout force. The concept of the kinematics, featured on the two telescopic wheel loaders AT900 and AT1050, has many advantages for the operator. In particular, the entire architecture of the lifting arm allows for **a perfect vision** onto the equipment and the working environment; both **the operator comfort and safety** do benefit from this.

PRECISE, EFFICIENT AND ALWAYS SAFE TO WORK WITH

The lifting cylinder and the two “parallel cylinders” are now placed on the underside of the telescopic arm which multiplies the lifting force and allows for unlimited parallel guidance. In addition, for each intervention, faster and more consistent handling of materials is provided. A guaranty for precision at work, efficiency and a high level of safety.

Designed by Mecalac, the telescopic arm of the AT wheel loaders is rigid and its kinematics allow for an optimal visibility on the equipment as well as the work area and the environment of the construction site. Thanks to the powerful engine, 55.4 kW / 75 hp (74.3 imperial hp), combined with a loading height of 4.67 m (15'3") and a maximum payload on forks, respectively 2350 kg (5,180 lb) and 2860 kg (6,305 lb), the AT900 and AT1050 present to our customers an efficient and effective management of very demanding jobs in a safe work environment.









USER-FRIENDLY

STURDY AND STABLE WITH FOUR-WHEEL STEERING

A RIGID FRAME, 4-WHEEL STEERING, STABILITY AND EXCELLENT MOBILITY

Combined with an extremely robust rigid chassis, the AT loaders stand for maximum stability, retaining the center of gravity even during tight turns or when driving on rough terrain. Thus the payload always being constant, the driver can work in confidence and focus entirely on his job.

Equipped with four-wheel steering, a steering angle of +/- 35° on each axle and a turning radius of only 3.71 m (12'2") over the rear, Mecalac's telescopic wheel loaders are highly adapted to off-road terrain with incomparable manoeuvrability and mobility, even on the tightest job sites.

This substantial ability also helps to reduce unnecessary movements to a considerable extent. This appreciable dexterity also reduces maneuvers considerably and with travel and cycle times optimised this contributes to the overall performance of a job site and meeting the given deadlines.

Even on the road, the Mecalac AT loaders do not fail their reputation for comfort and driving flexibility.

	ARTICULATED CHASSIS	RIGID CHASSIS	AT
Mobility	•		•
Versatility	•		•
Autonomy	•		•
Ease of driving	•		•
Off-road fitness	•		•
Safety		•	•
Stability		•	•
Precision			•



4





USER-FRIENDLY

GETTING IN AND OUT OF THE CAB WITHOUT GETTING TIRED

**IT IS ABOARD A SPACIOUS CABIN WITH
ERGONOMICALLY ARRANGED DRIVING ELEMENTS
WHERE THE DRIVER TAKES A SEAT.**

The large tinted windows provide excellent visibility; the panoramic roof offers a perfect view for example when loading at heights. The telescopic arm and the work area always remain in the operators' field of vision.

On top of the many comfort features that are standard in the Mecalac AT loaders, access by both sides of the machine is a powerful argument for many reasons.

In addition to maintaining maximum ventilation while keeping both doors open, being able to leave the cabin even when the machine is alongside a wall or an obstacle, is a definite plus. Staying in direct contact with the worksite environment and on-site workers in the handling phase is where attention to work must be at its maximum.



AT



USER-FRIENDLY

THE MECALAC QUICK-COUPLER, EQUIPPED AS STANDARD

EAGER TO MAKE ITS MACHINES EVER SAFER AND MORE VERSATILE, MECALAC, A SPECIALIST IN THE DESIGN AND MANUFACTURE OF CONSTRUCTION EQUIPMENT FOR URBAN WORKSITES, OFFERS A QUICK-COUPLER THAT IS REMARKABLE FOR ITS LIGHTWEIGHT, ITS INTEGRATION, ITS EASE OF USE AND ITS DOWNRIGHT PERFECT SAFETY.

Being multi-brand compatible, the Mecalac quick coupler can be controlled from the drivers' seat, without risk to drop the attachment due to its electro-hydraulic locking system. It's simple and fast maintenance minimises the interventions; this makes just one factor more for a well-performing and profitable building site. Versatility is an integral part of the Mecalac machine brand. A common purpose of any urban job site in the world lies in minimising the number of on-site transports, the number of machines in motion, the number of workers on the same site – to achieve an overall contribution to environmental protection in reducing noise and air pollution.

The Mecalac quick-coupler is the ultimate connection between the machine and its attachment.







OPTIMAL PERFORMANCES

Our goal is to become the long-term partner of each of our customers and that the Mecalac AT loaders contribute to the performance and profitability of their business.

This is why we are constantly listening to feedback from the field. As a result, our wheel loaders are equipped with many advanced technical features for optimal site management. We pay particular attention to the performance of our loaders, which are stable, maneuverable, compact, powerful and which guarantee operators the best comfort and perfect safety.





MECLAC

PERFORMANCE

MANEUVERABILITY AND COMPACTNESS

MECALAC TELESCOPIC WHEEL LOADERS FEATURE A RIGID FRAME AND 4-WHEEL STEERING. THEY OFTEN EVOLVE INTO URBAN CONSTRUCTION SITES WHERE SPACE IS LIMITED AND THEREFORE DRIVING IS LIMITED, TOO.

Being able to maneuver in a single movement within a radius of 3.71 m (12'2"), effectively bypassing all obstacles ensures maximum mobility on the tightest job sites. Stability is the key and no loss of tipping load occurs when the wheels are in steered position. Fewer turns, less movement, which means also less damage to the ground to preserve.

This combination of a rigid chassis, four-wheel steering and P-Kinematics results in the power and excellent handling of AT loaders, so tasks are carried out quickly and efficiently. It is this consistency of Mecalac technologies that defines our machines and is at the foundation of our success.

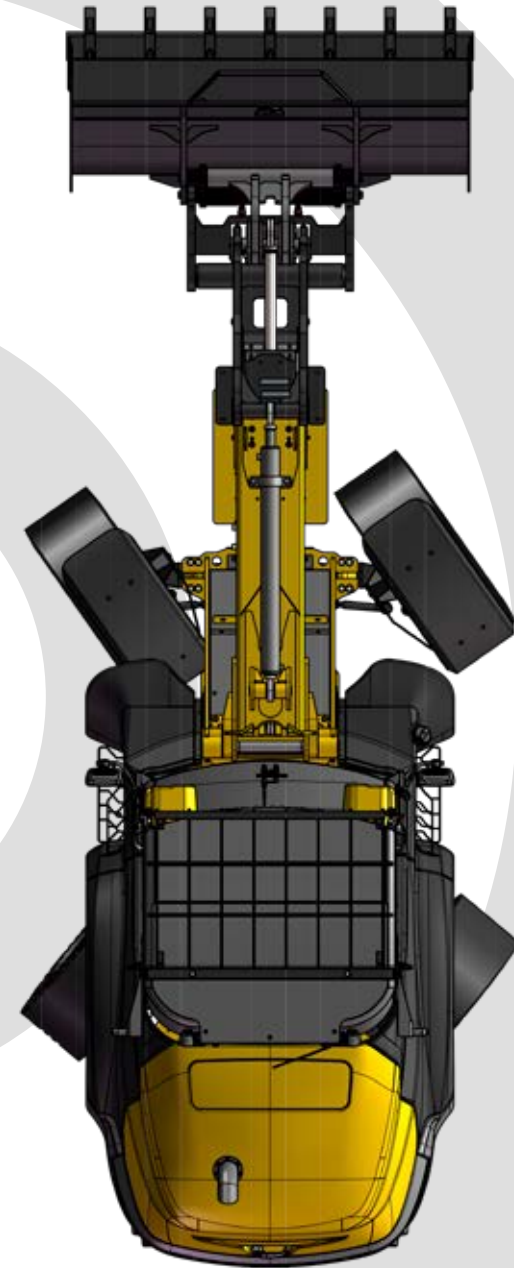



MOBILITY, THE ULTIMATE MANŒUVRABILITY

1 | *2-wheel steering* =
high traction and safe
travel on the road

2 | *4-wheel steering* =
mobility and stability on
construction sites

3 | *Crab mode* =
precise movements
in confined spaces

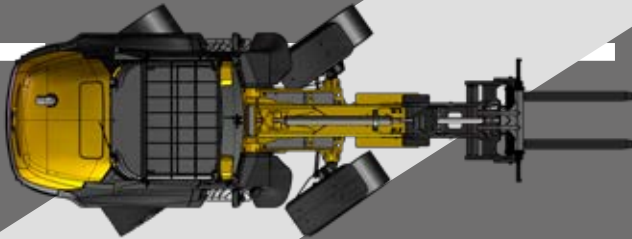

**THE 3 STEERING
MODES ALLOW THE
AT LOADERS TO
MASTER ANY SITUATION.**



PERFORMANCE

LIFTING FORCE AND WORKING RANGE

LIFTING FORCE

On demanding job sites, your Mecalac loader achieves, if equipped with loading forks, safely and efficiently, a maximum lifting height of 4.66 m (15'3"), a maximum reach of 3 m (9'9") and a maximum payload of 2350 kg (5,180 lb) for the telescopic loader model AT900 and 2860 kg (6,305 lb) for the model AT1050. Mecalac has chosen P-Kinematics for its AT loaders and as a result achieves unlimited parallel guidance when performing material handling jobs.



2+
TONS
[4,409 LB]

UPTO [15'3"]
4.66 M



WORKING RANGE

Equipped with a loading bucket, telescope retracted, the tipping load reaches 3470 kg (7,650 lb) and 4290 kg (9,457 lb) respectively, with a range of up to 3 m from the wheels.

The combination of this exceptional lifting force and working range allows AT loaders to perform a wide range of tasks for the most demanding applications. This is the guaranty of a highly performant and efficient result delivering the service, quality and profitability for the projects of our customers.

4.3
TONS
[9,479 LB]





PERFORMANCE

LOADING WITHOUT LIMITS

IN ADDITION TO MATERIAL HANDLING ALL DAY LONG, THE TELESCOPIC LOADER LOADS AND UNLOADS MANY TIMES AND ON ANY TERRAIN, FROM THE MOST ORDERLY TO THE MOST RUGGED.

Efficiency is the order of the day and safety is not just an empty word. Taking into account the autonomy of our customers, the telescopic loaders have been designed to provide real visibility on the work area and great freedom of maneuvering on all sites, whatever the job, whichever country.



UP TO [13'1"]
4M

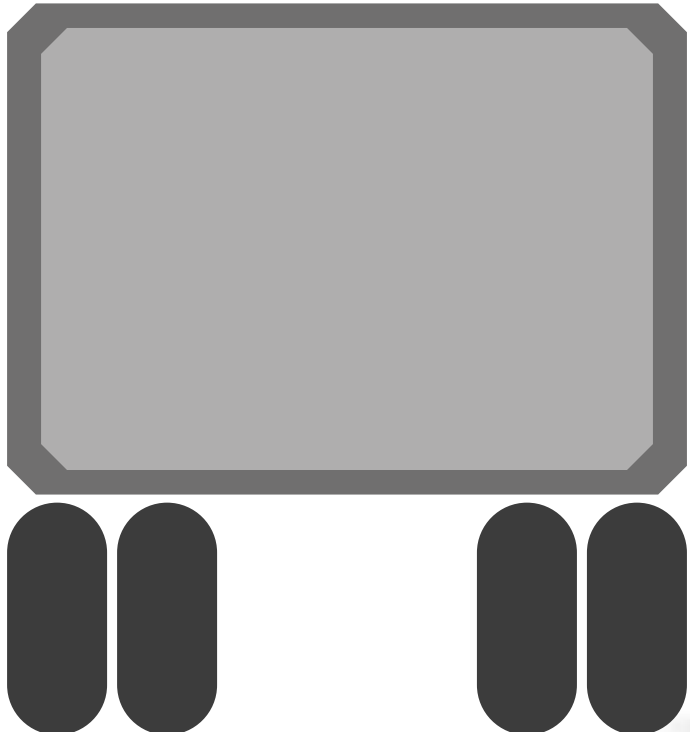

WHEN EQUIPPED WITH A LOADING BUCKET OR A MULTIPURPOSE BUCKET, UNLOADING IN THE DUMP OF A TRUCK CAN BE DONE AT MORE THAN 4 M HEIGHT, WHICH APPLIES TO BOTH MACHINES, THE AT900 AS WELL AS THE AT1050.

The telescopic arm extends by more than one meter and offers great loading possibilities in many work situations. Few situations will remain unresolved thanks to the AT telescopic loaders.





VERSATILITY, SERVING YOUR BUSINESS

**All Mecalac machines have one thing in common,
which is their built-in versatility.**

For the telescopic AT loaders, this versatility makes perfect sense for the integral optimisation and maximum profitability of our customers' work sites, whatever branch they are in, whatever their specialty.



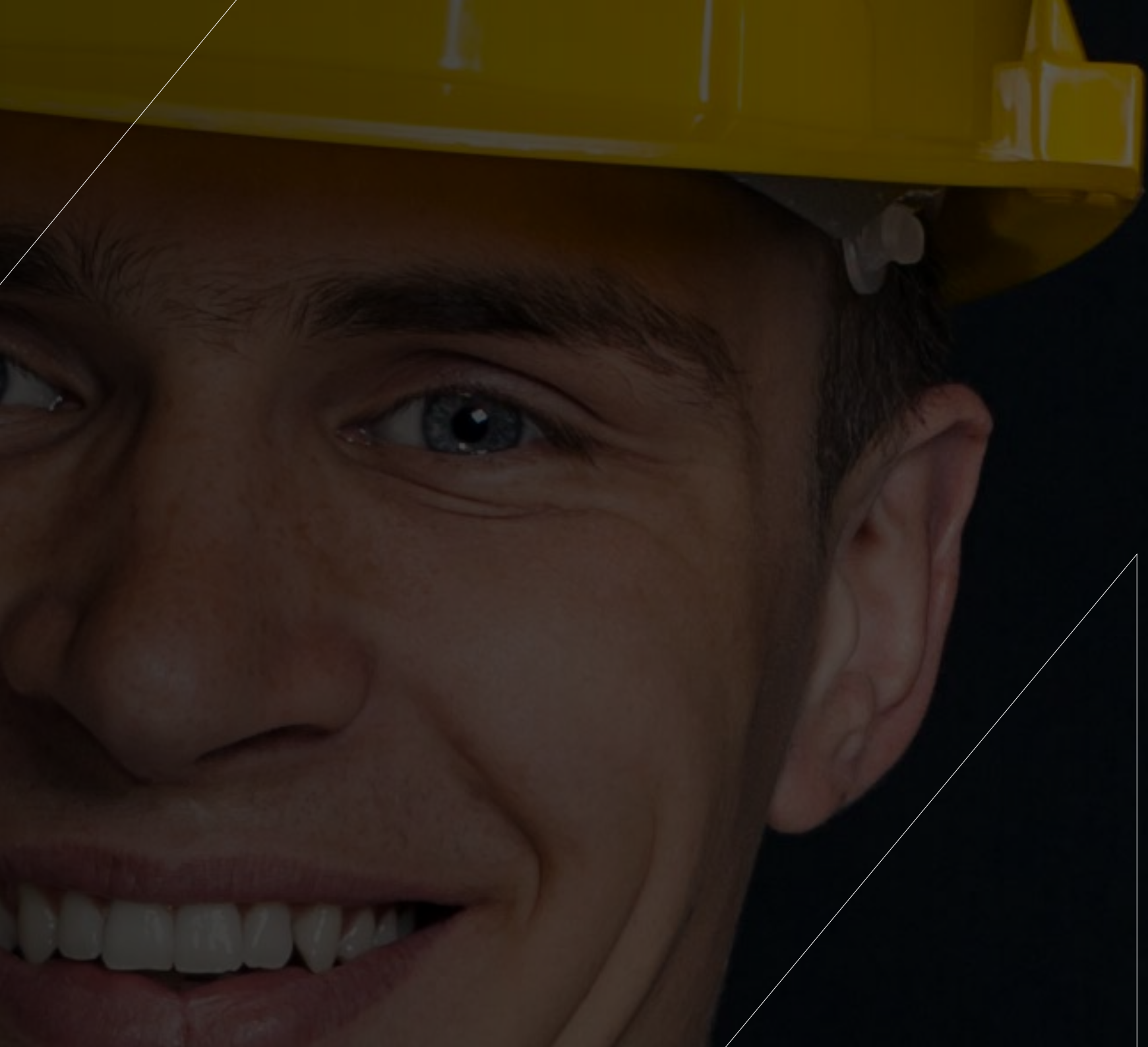



USER-FRIENDLY

A LOADER FOR EACH BUSINESS

HAVING THE RIGHT TOOL, AT THE RIGHT TIME, ALL YEAR LONG AND IN COMPLETE SAFETY - THAT IS MECALAC'S FUNDAMENTAL BASIS FOR EFFICIENT WORK OF QUALITY, HIGH PERFORMANCE, COST-EFFECTIVENESS AND ON-TIME JOB SITES.

Whether you work in industry, recycling, composting, local communities or furthermore in general construction, there is always a number of multiple and diverse tasks to perform, which are typical to your business. Material handling, loading, unloading, those are the daily tasks of your mission on the job site. The Mecalac telescopic loaders have been designed from the start to meet your demands for versatility without compromising performance, quality of work and the safety of the operator, the co-workers on the job site and the local residents. In addition to the standard buckets, the AT loaders are frequently operating hydraulic tools such as a sweeper, a brush cutter, a compactor, a milling cutter, a planer, a snow plow, a grapple bucket, ...there are as many possibilities to use your AT loader 365 days a year.



The temporary work platform in this brochure may only be sold in countries where it is approved. Check with your Mecalac dealer.







SET UP YOUR AT

The Mecalac telescopic loaders, AT900 and AT1050 come standard equipped with a number of features, while at the same time remaining attentive to the specifications required by various types of customers.

From the color scheme to the choice of tires or air-conditioning, not to mention the various attachments, buckets and hydraulic tools. There are many different ways to tailor your Mecalac wheel loader to your business.

CUSTOM COLORS

You wish to get your AT with your brand colors ?
Customize your Mecalac with your own RAL color codes.

Color examples



TIRE EXAMPLES



16/70 - 20 MPT04
Diagonal (standard)



16/70 - 20 MPT05
Radial



405/70 R20 SPT
Radial



405/70 R20
Radial



405/70 - 20 MPT01
Diagonal



550/45 - 22.5
Diagonal



12.00 X-Mine-D2
Radial



9.00 R20 X-Mine-D2
Radial



CABIN & COMFORT

Air-conditioning

Auxiliary heating

Cab pre-heating (up to -25°)

Steel-framed doors with sliding windows (on both sides)

Deluxe seat options, air-suspended, heated

Heated rear-view mirrors

ENGINE

Engine pre-heating (up to -25°)

Fuel pre-heating

Reversible fan

Electric fuel pump

Diesel Particulate Filter, DPF (standard in Europe)

TRANSMISSION

Hand throttle

Crawling speed (inching mode)

Ride control

Differential lock 100% on rear axle

HYDRAULIC OPTIONS

Push-pull couplings

Permanent function for attachment circuit

Pressureless return line / Leak-oil line

MPC - high-precision control for attachments

High-flow working hydraulics
(max. 120 l/min or 200 bar (2,900 psi))

Rear hydraulic circuit
(with permanent function)

Central lubrication system

Safety valves (on lifting and tipping cylinders)

SAFETY

Anti-theft device with transponder

Acoustic back-up alarm 110 dB

Working lights halogen / LED

Rotating beacon halogen / LED

Frontguard for windscreen

Preparation for telematics (interface)

HYDRAULIC OIL

Mineral hydraulic oil HV LP68

Bio-degradable oil HLP Synth 68S

Bio-degradable oil HLP Synth 46S

NOTE: METRIC MEASUREMENTS ARE THE CRITICAL VALUES

- 1 Litre = 0.26417 US Liquid Gallons
- 1 Litre = 0.21997 Imperial Liquid Gallons

**Standard and optional equipment may vary.
Consult your Mecalac dealer for details.**





EXCLUSIVE MECALAC ACCESSORIES



LOADING SHOVELS

AT900	VOLUME m ³ (yd ³)	WIDTH mm (ft)	WEIGHT kg (lb)	Max. Density t/m ³ (lb/y ³)
Bucket with teeth	0.9 (1.18)	2100 (6'10.68")	359 (791)	1.8 (3,034)
Bucket w/o teeth	0.9 (1.18)	2100 (6'10.68")	324 (714)	1.8 (3,034)

AT1050	VOLUME m ³ (yd ³)	WIDTH mm (ft)	WEIGHT kg (lb)	Max. Density t/m ³ (lb/y ³)
Bucket with teeth	1.05 (1.37)	2100 (6'10.68")	410 (903)	1.8 (3,034)
Bucket w/o teeth	1.05 (1.37)	2100 (6'10.68")	375 (826)	1.8 (3,034)

4X1 MULTI-PURPOSE BUCKETS

AT900	VOLUME m ³ (yd ³)	WIDTH mm (ft)	WEIGHT kg (lb)	Max. Density t/m ³ (lb/y ³)
Multi-purpose bucket with teeth	0.85 (1.11)	2100 (6'10.68")	633 (1,395)	1.8 (3,034)
Multi-purpose bucket w/o teeth	0.85 (1.11)	2100 (6'10.68")	598 (1,318)	1.8 (3,034)

AT1050	VOLUME m ³ (yd ³)	WIDTH mm (ft)	WEIGHT kg (lb)	Max. Density t/m ³ (lb/y ³)
Multi-purpose bucket with teeth	1 (1.3)	2100 (6'10.68")	643 (1,417)	1.8 (3,034)
Multi-purpose bucket w/o teeth	1 (1.3)	2100 (6'10.68")	608 (1,340)	1.8 (3,034)

GRAB BUCKETS

AT1050	VOLUME m ³ (yd ³)	WIDTH mm (ft)	WEIGHT kg (lb)	Max. Density t/m ³ (lb/y ³)
Bucket with grapple	1.4 (1.83)	2100 (6'10.68")	548 (1,208)	0.9 (1,517)

HIGH CAPACITY BUCKETS

AT900 / AT1050	VOLUME m ³ (yd ³)	WIDTH mm (ft)	WEIGHT kg (lb)	Max. Density t/m ³ (lb/y ³)
Lightweight bucket with teeth	1.2 (1.57)	2100 (6'10.68")	422 (930)	1.2 (2,023)
Lightweight bucket w/o teeth	1.5 (1.96)	2100 (6'10.68")	580 (1,278)	0.9 (1,517)

AT1050	VOLUME m ³ (yd ³)	WIDTH mm (ft)	WEIGHT kg (lb)	Max. Density t/m ³ (lb/y ³)
Lightweight bucket w/o teeth	2 (2.62)	2100 (6'10.68")	627 (1,382)	0.7 (1,180)

BUCKET ACCESSORY

AT900 / AT1050

- Loading hook on multi-purpose bucket
- Bucket cover with lights acc. to traffic regulations – for buckets with/without teeth
- Hardox double-sided bolted cutting edge for all buckets without teeth

*The laws and regulations of the different countries must be respected.

PALLET FORKS

AT900 / AT1050	TINE LENGTH mm (ft)	MAX. LOAD kg (lb)	WEIGHT kg (lb)
Pallet fork carrier	1200 (3'11.24")	2500 (5,511)	210 (463)

CRANING DEVICE

AT900 / AT1050	LENGTH mm (ft)	MAX. LOAD kg (lb)	WEIGHT kg (lb)	REACH mm (ft)
Craning device	1920 (6'3.59")	800 (1,763)	204 (449)	3155 / 4200 (10'4.21" / 13'9.35")

ROAD SWEEPER

AT900 / AT1050

Cleaning brush (working width straight 2300 mm (7'6.55")) with mechanical adjustment of lateral angle. Brush diameter 600 mm (1'11.62"), 100% PP, supporting wheels Ø 250 mm (0'9.84").

Dirt container (355 L), with supporting wheel

Sprinkler system, tank capacity 200 L, 12/24 Volt

Side brush

SNOW PLOW

AT900 / AT1050

Snow plow (working width straight 2500 mm (8'2.42"), lateral 2160 mm (7'1")) with mechanical lateral adjustment and supporting wheels Ø 200 mm (0'7.87")

Hydraulic lateral adjustment of the snow plow

REAR MOUNTINGS*

	AT900	AT1050
Fold-away, height adjustable ball type hitch. Max. towing capacity 3500 kg (7,716 lb) for breaked trailer, max. towbar load: 100 kg (220 lb) with 7-pole socket (12V)	•	
Rockinger trailer coupling, pivotable, 38 mm (0'1.49") pin diameter max. towing capacity 8000 kg (17,636 lb) for breaked trailer, max. towbar load: 200 kg (440 lb) with 7-pole socket (12V)	•	•
Rear mounting bracket (cat I) to carry sand- and salt-spreader with 7-pole socket (12V)	•	

REAR-MOUNTED ATTACHMENTS

	AT900	AT1050
Sand- and salt spreader SA 360 (360L), consisting of: spreader, paddle mixer, electric remote control, lighting, with 7-pole socket (12V)	•	

NOTE: METRIC MEASUREMENTS ARE THE CRITICAL VALUES

- 1 Litre = 0.26417 US Liquid Gallons
- 1 Litre = 0.21997 Imperial Liquid Gallons

AT

TECHNICAL DATA

WEIGHT	AT900	AT1050
Operating weight	6550 kg (14,400 lb)	7150 kg (15,763 lb)
Engine output	55.4 kW / 75 hp (74.3 imperial hp)	55.4 kW / 75 hp (74.3 imperial hp)
Bucket capacity	0.9 – 1.5 m ³ (1.18 - 1.96 yd ³)	1.05 – 1.6 m ³ (1.37 - 2.1 yd ³)

ENGINE	AT900	AT1050
Low-noise, water-cooled Deutz TCD 2.9 L4, turbo diesel engine. Common Rail injection system, cooled external exhaust gas recirculation, diesel oxidation catalyst (DOC).	EU Stage V / U.S. EPA Tier 4 Final*	
Net power at: Acc. to ISO 14396	2,300 rpm 55.4 kW / 75 hp (74.3 imperial hp)	2,300 rpm 55.4 kW / 75 hp (74.3 imperial hp)
Max. torque at: Acc. to ISO 14396	1,600 rpm 300 Nm	1,600 rpm 300 Nm
Air intake filter: two-stage dry-air filter with safety cartridge	•	•

*Depending on your Local Legislation - Environmental Protection Agency (EPA)

ELECTRICAL SYSTEM	AT900	AT1050
Operating voltage	12 Volt	12 Volt
Battery	95 Ah	95 Ah
Alternator	120 A	120 A

DRIVE	AT900	AT1050
Hydrostatic drive with automotive control, 2 stages for maximum propulsive force, shiftable under load, multifunctional lever (joystick) for drive and working hydraulics control	•	•
Axes: planetary axles with four- wheel steering for maximum manoeuvrability, oscillating rear axle with suspension	•	•
Differential lock: self-locking differential in front axle	•	•
Tyres	16/17-20	16/17-20
Standard	16/17-20	16/17-20
Optional	405/70 R20	405/70 R20
Speeds		
Road gear	0-20 km/h (0-12 mph)	0-20 km/h (0-12 mph)
Field gear	0-5 km/h (0-3.1 mph)	0-5 km/h (0-3.1 mph)
Optional	30-40 km/h (19-25 mph)	30-40 km/h (19-25 mph)
Oscillation: max. oscillation angle	+/-10°	+/-10°

BRAKE SYSTEM	AT900	AT1050
Working brakes		
1. hydrostatic inching brake, acting on all 4 wheels	•	•
2. hydraulically operated, servo-assisted oil-immersed multiple disc brakes on front axle, acting on all 4 wheels	•	•
Parking brake	•	•
spring loaded brake on front-axle acting on all 4 wheels	•	•

STEERING	AT900	AT1050
Hydrostatic four-wheel steering with 3 steering modes with automatic alignment (four-wheel, front-wheel and crab steer)	•	•
Max. steering angle	+/-35°	+/-35°
Turning radius		
Measured over rear	3710 mm (12'2.06")	3710 mm (12'2.06")
Measured over bucket	4600 mm (15'1.1")	4630 mm (15'2.2")

AT

TECHNICAL DATA

HYDRAULIC SYSTEM	AT900	AT1050
Single circuit working hydraulics with gear pump (lift/lower, tilt, telescopic functions, quick-attach system) and steering (via priority valve); four-way control valve with primary and secondary safeguards	•	•
Max. performance at 2300 rpm	84 l/min (22.2 gal) and 225 bar (3,263 psi)	84 l/min (22.2 gal) and 225 bar (3,263 psi)

Floating position for boom cylinders

Cylinders:

- 1 lifting cylinder
- 1 tilting cylinder
- 1 telescopic cylinder

•	•
•	•
•	•

PERFORMANCE DATA	AT900	AT1050
Digging depth with standard bucket	90 mm (0'3.94")	90 mm (0'3.94")
Bucket position		
Crowd angle	45°	45°
Dump angle top	45°	45°
Dump angle max.	110°	110°
Lifting force	44 kN (9891 lbf)	52 kN (11,690 lbf)
Breakout force	43.6 kN (9801 lbf)	43.6 kN (9801 lbf)
Traction force	48.5 kN (10,903 lbf)	48.5 kN (10,903 lbf)
Tippling load, telescope retracted		
Standard bucket, max. steered, frontal	3470 kg (7,650 lb)	4290 kg (9,458 lb)
Payload		
Forks, max. steered, frontal, even terrain	2350 kg (5,180 lb)	2860 kg (6,305 lb)
Forks, max. steered, frontal, even terrain*	2600 kg (5,732 lb)	3150 kg (6,945 lb)

FILLING CAPACITIES	AT900	AT1050
Engine with filter	approx 8 l (2.1 gal)	approx 8 l (2.1 gal)
Fuel tank	approx 130 l (34.3 gal)	approx 130 l (34.3 gal)
Front axle total	approx 11 l (2.9 gal)	approx 11 l (2.9 gal)
Rear axle with gearbox	approx 12 l (3.2 gal)	approx 12 l (3.2 gal)
Hydraulic system with tank	approx 134 l (35.4 gal)	approx 134 l (35.4 gal)

* Tipping load acc. to ISO 14397; Payload acc. to EN 474-3. Transport position 300 mm (0'11.81") above ground level.

NOTE: METRIC MEASUREMENTS ARE THE CRITICAL VALUES

- 1 Litre = 0.26417 US Liquid Gallons
- 1 Litre = 0.21997 Imperial Liquid Gallons

CONCEPTION	AT900	AT1050
Comfortable panoramic driver's cab with ROPS safety system	•	•
Monoboom with P-Kinematics	•	•
Joystick controls	•	•
Servo-assisted working hydraulics	•	•
Hydraulically controlled quick-attach system	•	•
High-performance, power controlled hydrostatic four-wheel drive	•	•
Four-wheel steering system with automatic alignment	•	•
Planetary axles with self-locking differential on front axle	•	•
Wide range of attachments	•	•
Rigid, single-component chassis for maximum stability, independent of steering position	•	•
Powerful telescopic boom with P-Kinematics with precise parallel guidance	•	•
The monoboom concept guarantees optimum visibility to attachments	•	•
Operator's cab with flexible four-point mountings for maximum driver comfort and minimum noise levels	•	•
The servo-assisted joystick controls of the working hydraulics are smooth, accurate and long lasting	•	•

EMISSIONS	AT900	AT1050
Engine: emissions according EU-RL 97/68	EU Stage V / U.S. EPA Tier 4 Final*	
Noise emission:		
Sound power level LWA ¹	100 dB(A)	100 dB(A)
Acoustic power level LpA ²	75 dB(A)	75 dB(A)
Vibrations:		
Vibration total value ³	< 2.5 m (8'2")/s ²	< 2.5 m (8'2")/s ²
Effective vibration level ⁴	< 0.5 m (1'7")/s ²	< 0.5 m (1'7")/s ²

* Depending on your Local Legislation - Environmental Protection Agency (EPA)

¹ According to 2000/14/EG

² According to ISO 6396

³ According to ISO/TR 25398

⁴ According to ISO/TR 25398

All information pertains to the standard tyres.

All information is non-binding.

Subject to change without prior notice.

The order confirmation alone is expressly decisive.

AT

TECHNICAL DATA

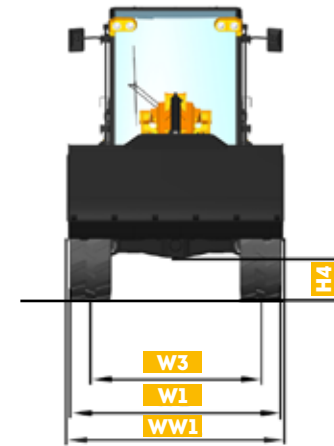
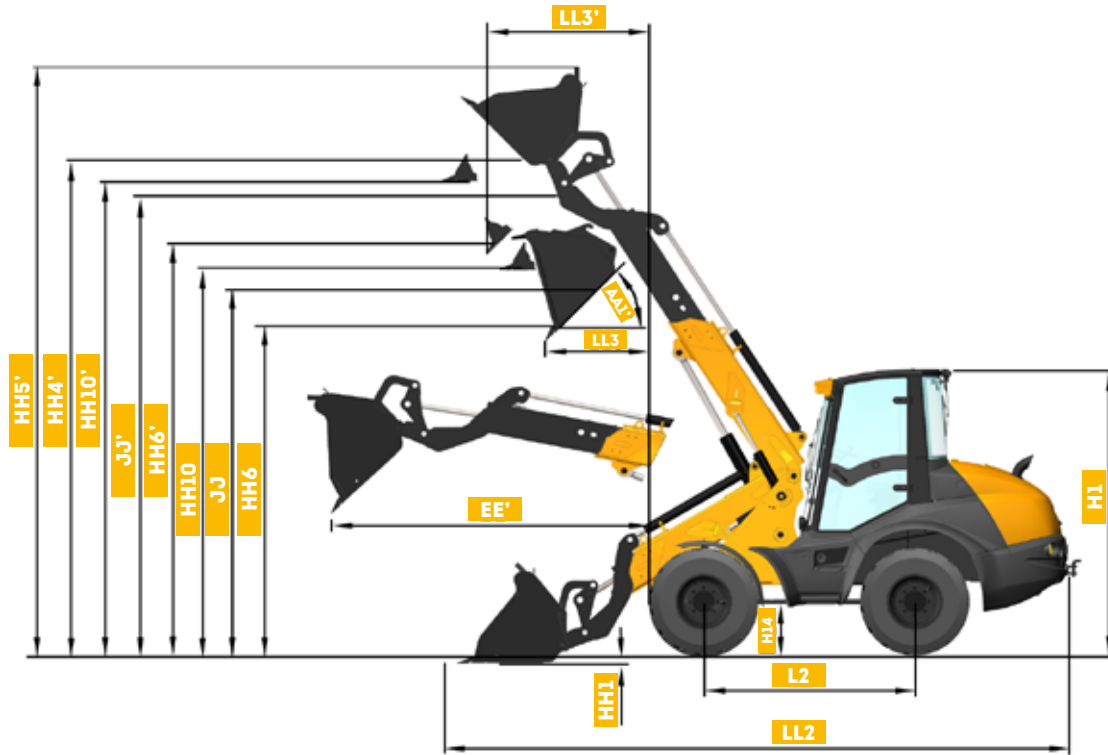

MACHINE DIMENSIONS	AT900		AT1050	
BUCKET	STD. 0.9 m ³ (1.18 yd ³)	4x1 - 0.85 m ³ (1.11 yd ³)	STD. 1.05 m ³ (1.37 yd ³)	4x1 - 1.0 m ³ (1.3 yd ³)
AA1'	45°		45°	
EE'	3010 mm (9'10.5")	2955 mm (9'8.34")	3010 mm (9'10.5")	2955 mm (9'8.34")
HH1	90 mm (0'3.54")	110 mm (0'4.33")	90 mm (0'3.54")	110 mm (0'4.33")
HH10	3780 mm (12'4.82")	3765 mm (12'4.23")	3780 mm (12'4.82")	3765 mm (12'4.23")
HH10'	4670 mm (15'3.86")	4630 mm (15'2.28")	4670 mm (15'3.86")	4630 mm (15'2.28")
HH4'	4830 mm (15'10.16")	4830 mm (15'10.16")	4830 mm (15'10.16")	4830 mm (15'10.16")
HH5'	5850 mm (19'2.31")	6010 mm (19'8.61")	5850 mm (19'2.31")	6010 mm (19'8.61")
HH6	3200 mm (10'5.98")	3145 mm (10'3.82")	3170 mm (10'4.8")	3145 mm (10'3.82")
HH6'	4080 mm (13'4.63")	4010 mm (13'1.87")	4050 mm (13'3.45")	4010 mm (13'1.87")
JJ	3660 mm (12'0.09")	3665 mm (12'0.29")	3560 mm (11'8.16")	3665 mm (12'0.29")
JJ'	4440 mm (14'6.8")	4530 mm (14'10.35")	4440 mm (14'6.8")	4530 mm (14'10.35")
LL3	850 mm (2'9.46")	1095 mm (3'7.11")	870 mm (2'10.25")	1095 mm (3'7.11")
LL3'	1500 mm (4'11.06")	1680 mm (5'6.14")	1500 mm (4'11.06")	1680 mm (5'6.14")

MACHINE DIMENSIONS	AT900	AT1050
H1	2910 mm (9'6.57")	2910 mm (9'6.57")
H4	345 mm (1'1.58")	345 mm (1'1.58")
H14	420 mm (1'4.54")	420 mm (1'4.54")
L2	2085 mm (6'10.09")	2085 mm (6'10.09")
W1	2065 mm (6'9.3")	2065 mm (6'9.3")
W3	1660 mm (5'5.35")	1660 mm (5'5.35")
WW1	2100 mm (6'10.68")	2100 mm (6'10.68")
LL2	5850 mm (19'2.31")	5920 mm (19'5.07")

*Depending on choice of tyres

AT

TECHNICAL DATA

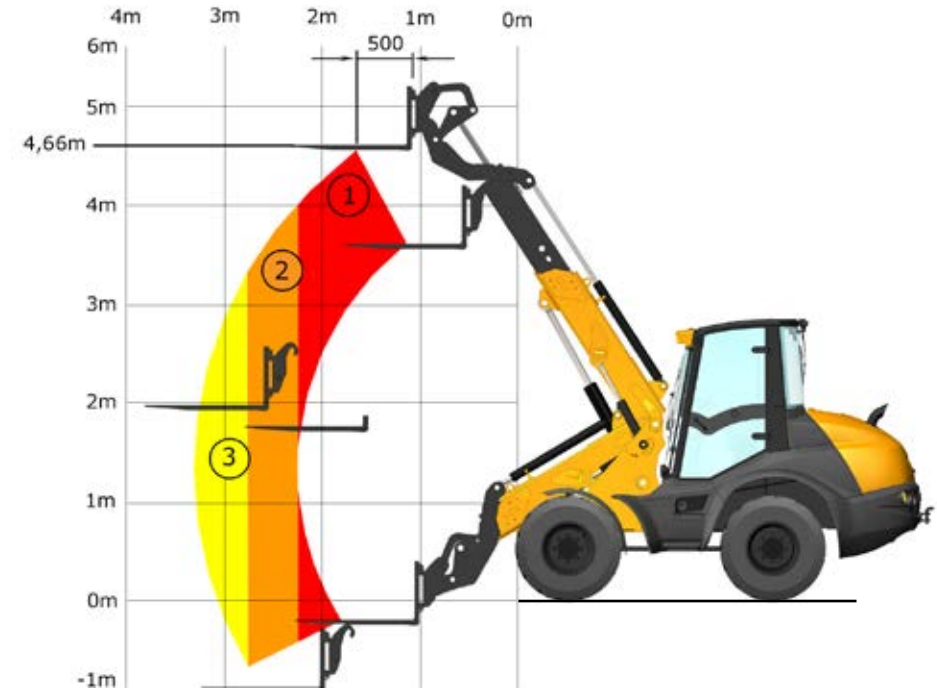
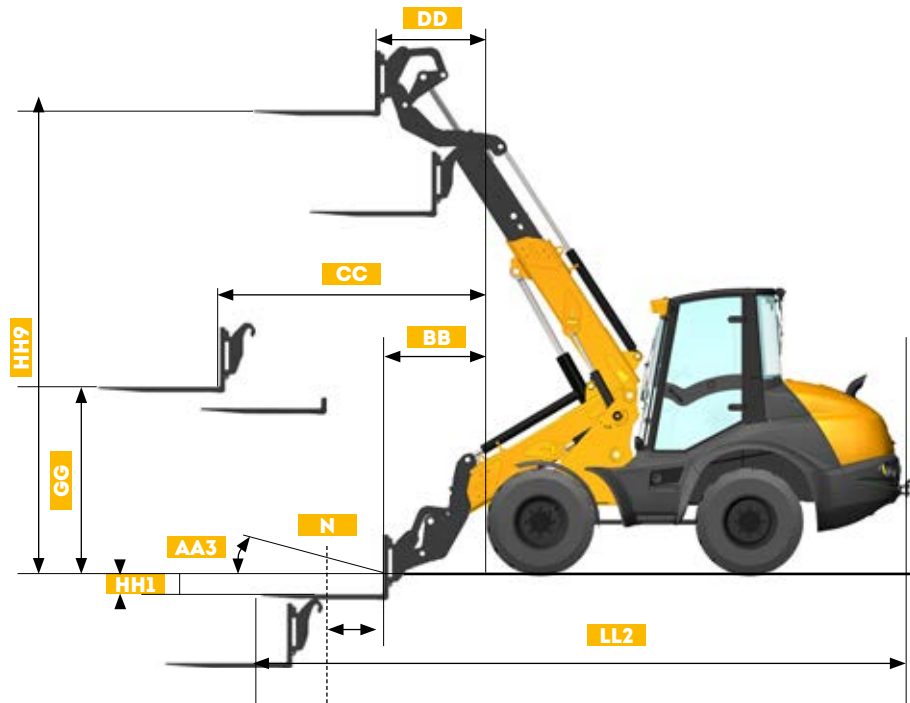

DIMENSIONS WITH PALLET FORK		AT900	AT1050
PALLET FORK			
LL2	Overall length	6350 mm (20'10")	6350 mm (20'10")
BB	Minimum reach	1030 mm (3'4.55")	1030 mm (3'4.55")
CC	Maximum reach	2600 mm (8'6.36")	2600 mm (8'6.36")
AA3	Tipping angle max.	max. 15°	max. 15°
DD	Reach at maximum lifting height	1090 mm (3'6.91")	1090 mm (3'6.91")
GG	Loading height at maximum reach	1950 mm (6'4.77")	1950 mm (6'4.77")
HH1	Plunge depth	210 mm (0'8.27")	210 mm (0'8.27")
HH9	Overload height at max. lifting height	4660 mm (15'3.46")	4660 mm (15'3.46")
N	Payload - at maximum reach	1730 kg (3814 lb)	1730 kg (3814 lb)
N	Payload at 300 mm above ground	The payload of the machine is limited by the maximum weight on forks at 2500 kg (5,511 lb)	

PAYLOAD (80 % of tipping load)		AT900	AT1050
EVEN GROUND 80%			
①	Permissible load according to EN 474-3	2350 kg (5,181 lb)	2860 kg (6,305 lb)
②	Permissible load according to EN 474-3	1730 kg (3,814 lb)	2150 kg (4,740 lb)
③	Permissible load according to EN 474-3	1420 kg (3,130 lb)	1800 kg (3,968 lb)

MECALAC FRANCE S.A.S.
2, avenue du Pré de Challes
Parc des Glaisins – CS 40230
Annecy-le-Vieux
FR - 74942 Annecy Cedex
Tel. +33 (0)4 50 64 01 63

**MECALAC BAUMASCHINEN
GMBH**
Am Friedrichsbrunnen
D-24782 Búdelsdorf
Tel. +49 (0)43 31/3 51-319

**MECALAC CONSTRUCTION
EQUIPMENT UK LTD**
Central Boulevard,
ProLogis Park
Coventry, CV6 4BX, UK
Tél. +44 (0)24 7633 9539

**MECALAC İŞ MAKİNELERİ
SAN VE TIC. LTD. ŞTİ.**
Ege Serbest Bölgesi Nilüfer 1 Sok. No: 34
35410, Gaziemir
İzmir - Türkiye
Tel. +90 232 220 11 15



WWW.MECALAC.COM

Materials and specifications are subject to change without notice. Actual products may differ from photos. Featured machines in photos may include additional equipment. See your Mecalac dealer for available options.

2019 Mecalac © All rights reserved. **Design** Les Alchimistes **Photo credits** Münchow Industriefotos - Fotolia **Printed by** Kallistene **Non-contractual document** **MIK337-EN-11/19 AT SERIES**