

Product Information

MR1K-008..025GM / K

Flow Switch MR1K-



- High switching power
- Compact design

Characteristics

Mechanical flow switch, for fluid or gaseous media, with spring-supported piston and magnetic triggering of a reed switch. Robust construction in brass or stainless steel.

Technical data

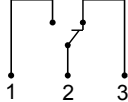
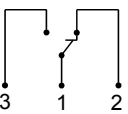
Switch	reed switch	
Nominal width	DN 8..25	
Process connection	female thread G 1/4..G 1 (further process connections available on request)	
Switching range	0.4..60 l/min	for details see table "Ranges"
Pressure loss	0.4..1.4 bar at Q _{max.}	
Q_{max.}	to 80 l/min	
Tolerance	±5 % of full scale value	
Pressure resistance	PN 200 bar optionally PN 500 bar	
Media temperature	-20..+120 °C optionally -20..+150 °C	
Ambient temperature	-20..+70 °C	
Media	water (oils, gases and aggressive media available on request)	
Wiring	changeover no. 0.213  optionally changeover no. 0.282  optionally red or red / green diode in the DIN 43650-A plug	
Switching voltage	max. 250 V AC	
Switching current	max. 1.5 A	
Switching capacity	max. 50 VA	
Protection class	2 - safety insulation	
Ingress protection	IP 65	
Electrical connection	plug DIN 43650-A / ISO 4400, optionally round plug connector M12x1, 4-pole	

Materials medium-contact	<i>Brass construction:</i> CW614N nickelled, CW614N, 1.4310, hard ferrite, NBR	<i>Stainless steel construction:</i> 1.4571, 1.4404, 1.4310, hard ferrite PTFE-coated, FKM
Non-medium-contact materials	PA, CW614N, NBR	
Weight	see table "Dimensions and weights"	
Installation location	Standard: horizontal inwards flow from the left; other installation positions are possible; the installation position affects the switching point and range.	

Ranges

For switching ranges, the details in the table correspond to horizontal inwards flow and decreasing flow rate; for display ranges they correspond to horizontal inwards flow and increasing flow rate.

Switching range l/min H ₂ O	Display range l/min H ₂ O		Q _{max.} recommended	Pressure loss bar at Q _{max.} H ₂ O
	O / O1	J		
0.4 - 4	0.5 - 5	0.4 - 4	10	0.6
1.0 - 10	1.0 - 12	1.0 - 10	20	
2.0 - 20	2.0 - 23	2.0 - 20	30	0.4
3.0 - 30	3.0 - 34	3.0 - 30	40	
4.0 - 40	4.0 - 45	4.0 - 40	60	0.8
6.0 - 60	6.0 - 65	6.0 - 60	80	
			80	1.4

Special ranges are available.

Dimensions and weights

	G	Types	SW	X	Weight kg
Brass	G 1/4	MR1K-008GM	40	15	1.3
	G 3/8	MR1K-010GM			
	G 1/2	MR1K-015GM		18	1.2
	G 3/4	MR1K-020GM			
	G 1	MR1K-025GM			
Stainless steel	G 1/4	MR1K-008GK	41	15	1.2
	G 3/8	MR1K-010GK			
	G 1/2	MR1K-015GK		18	1.1
	G 3/4	MR1K-020GK			
	G 1	MR1K-025GK			

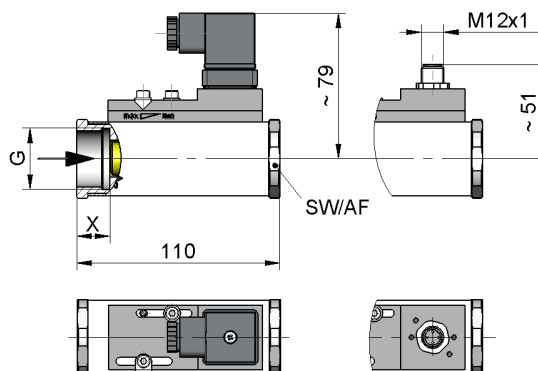

Additional weights for options

Additional switching head	0.09 kg	Display O	0.09 kg
Display O1	0.04 kg	Display J	0.02 kg

Product Information

MR1K-008..025GM / K

Handling and Operation

Note

- Include straight calming section of 5 x DN in inlet and outlet
- Include a filter if the media are dirty (use magnetic filter for ferritic components).
- It must be ensured that the values given for voltage, current, and power are not exceeded.
- When switch on, a load must be connected in series.
- The electrical details apply to ohmic loads. Capacitive, inductive and lamp loads must be operated using a protective circuit.

Adjustment

If it is necessary to set the switching value, the switching head can be adjusted lengthways. When the switching value is reached, the switching unit is fixed in place by fastening bolts.



Ordering code

MR1K 1. 2. 3. **G** 4. 5.

1. Display options	
-	no mechanical display
O1-	with measurement display at side O1
O-	with measurement display at side O
J-	with frontal measurement display J
2. Nominal width	
008	DN 8 - G 1/4
010	DN 10 - G 3/8
015	DN 15 - G 1/2
020	DN 20 - G 3/4
025	DN 25 - G 1
3. Process connection	
G	female thread
4. Connection material	
M	brass
K	stainless steel
5. Switching range H₂O for horizontal inwards flow	
004	0.4 - 4 l/min
010	1.0 - 10 l/min
020	2.0 - 20 l/min
030	3.0 - 30 l/min
040	4.0 - 40 l/min
060	6.0 - 60 l/min



MR1K01

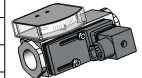

MR1K0

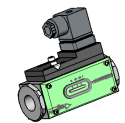

MR1KJ

Options

- Signal lamp red or red / green in the plug DIN 43650-A
- Connection for round plug connector M12x1
- Reinforced piston
- Additional switching head
- High pressure model PN 500 (only if made of brass)
- Damping for gas monitoring
- Rhodium contact 250 V AC, 0.5 A, 30 VA
- Switching values for oil or gas
- Special values
- Temperature display 0..120 °C

Ordering information

- Specify direction of flow, medium, and switching range.
- For viscous media specify viscosity, temperature, and medium (e.g. ISO VG 68) (enquire about switching range).
- For gases, state pressure (relative or absolute), temperature and medium (e.g. air) (request switching range).