

**Product Information**

**RM-008..025GR / K**

**Flow Indicator RM**



- Good view of rotor
- High temperature resistance
- Dome form

**Characteristics**

Mechanical flow indicator, for fluid media, with rotor for quantitative flow display. The rotor turns in proportion to the flow. Robust construction using red bronze / brass or stainless steel.

**Technical data**

<b>Nominal width</b>	DN 8.0.25	
<b>Process connection</b>	female thread G 1/4..G 1	
<b>Display range</b>	0.7..60 l/min	for details see table "Ranges"
<b>Pressure loss</b>	up to 0.7 bar	
<b>Q<sub>max.</sub></b>	to 60 l/min	
<b>Pressure resistance</b>	PN 16 bar	
<b>Medium temperature</b>	0..+100 °C water 0..+200 °C oils	
<b>Ambient temperature</b>	0..+200 °C	
<b>Materials medium-contact</b>	<i>red bronze model:</i> Rg, CW614N, borosilicate glass, 1.4301, PPS, Klengersil C-4400	<i>Stainless steel construction:</i> 1.4408, CW614N, borosilicate glass, 1.4301, PPS Klengersil C-4400
<b>Medium</b>	water (oils have a tendency to a higher running-up value)	
<b>Weight</b>	see table "Dimensions and weights"	
<b>Installation location</b>	as desired, except for inwards flow from above	

**Ranges**

G	Types	Running-up amount for rotor l/min H <sub>2</sub> O	Q <sub>max.</sub> re-com-mended	Pressure loss bar at Q <sub>max.</sub> H <sub>2</sub> O
G 1/4	RM-008G.	0.7	8	0.20
G 3/8	RM-010G.	0.8	10	0.15
G 1/2	RM-015G.	1.0	20	0.40
G 3/4	RM-020G.	1.2	40	0.25
G 1	RM-025G.	1.5	60	0.70

**Dimensions and weights**

G	Types	L	H	SW	X	Weight kg
G 1/4	RM-008G.	76	53	28	12	0.70
G 3/8	RM-010G.				16	0.65
G 1/2	RM-015G.				14	
G 3/4	RM-020G.	89	66	45	18	1.25
G 1	RM-025G.					1.20

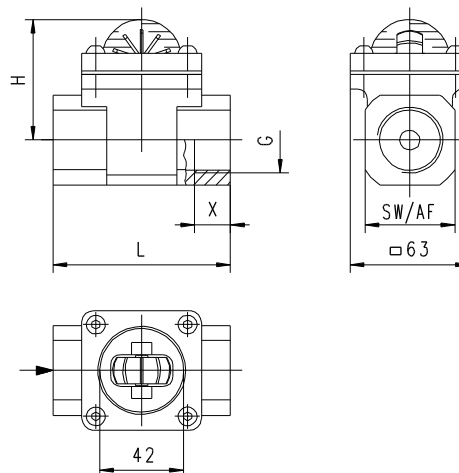

**Ordering code**

1. 2. 3.  
RM -  **G**

○=Option

1. Nominal width	
008	DN 8 - G 1/4
010	DN 10 - G 3/8
015	DN 15 - G 1/2
020	DN 20 - G 3/4
025	DN 25 - G 1
2. Process connection	
G	female thread
3. Connection material	
R	red bronze
K	○ stainless steel