



MOULDED CABINET LOUDSPEAKERS

PMC4T/EN



The moisture-proof surface-mounted loudspeaker PMC4T/EN is made of ABS plastic. Supplied with a special impregnated chassis, it is very good for use in areas for wet rooms. Likewise, this speaker for example, can be used outdoors by ships.

PMC4T/EN is ideal for speech and light background music. In accordance with the British Standard 6840, this speaker is suitable for use in humid rooms and premises where frequent superficial cleaning of the speakers is required.



EN54-24:2008 0905-CPR-00280 TYPE B

● Standard	Compliant to EN54-24 Compliant to BS5839:8
● Electrical	
Rated power, Watts	4
Tappings 100 Volt line, Watts	4/2/1/0.5
Transformer Impedance, Ohms 100 Volt	2.5/5/10/20k
Tappings 70.7 Volt line, Watts	2/1/0.5/0.25
Driver impedance, Ohms	8
Effective Frequency Range, Hz (BSEN60268-5)	220-11.000
S.P.L. @ 1 m, 1 Watt, dB, Octave, 100 Hz-10 kHz	92
S.P.L. @ 1 m, Full power, dB, Octave, 100 Hz-10 kHz	98
S.P.L. @ 4 m, 1 Watt, dB, 1/3 Octave, 100 Hz-10 kHz	76
S.P.L. @ 4 m, Full power, dB, 1/3 Octave, 100 Hz-10 kHz	78
Dispersion at 1k/2k Hz, Degrees	181/105 Horizontal 197/115 Vertical
● Environmental	
IP Rating	56
Min/Max amb temp	-25°C to 70°C
Relative Humidity	≤95%
● Mechanical	
Dimensions, WxHxD mm	119x119x84
Net weight, kg	1.0
Colour (Unless Specified)	White, RAL9016
Material	Low smoke zero halogen UL-94V0 Plastic with UV inhibitors
Mounting	4 x screw fixings
Safety	Ceramic Block Thermal Fuse



ATEIS Europe B.V.
Celsiusstraat 1, 2652 XN Lansingerland, Netherlands
Phone +31 (0)10 208 86 90, www.ateis-europe.com, info@ateis-europe.com





PENTON

INSTALLATION GUIDE

PMC4T/EN

EN54-24:2008

0905-CPR-00280

TYPE B

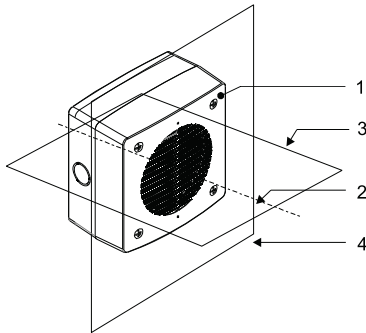
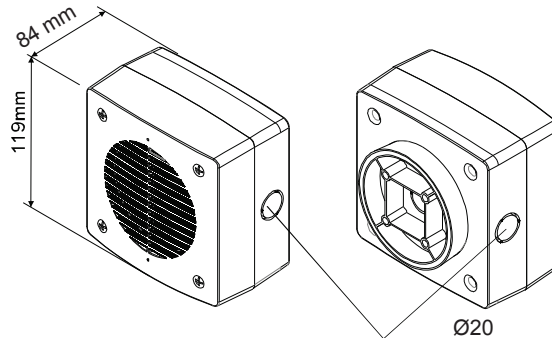

1. Loudspeaker enclosure
2. Reference axis
3. Horizontal plane
4. Reference plane

**With Transformer:
100V/70V line**

	White wire plus tapping				Black
100V	0.5W	1W	2W	4W	COM
70V	0.25W	0.5W	1W	2W	COM
IMP (Ω)	20K	10K	5K	2.5K	

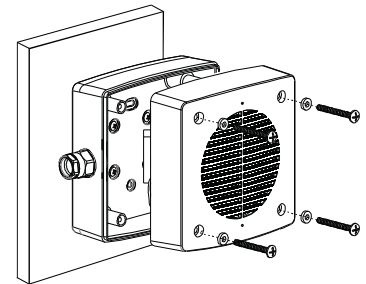
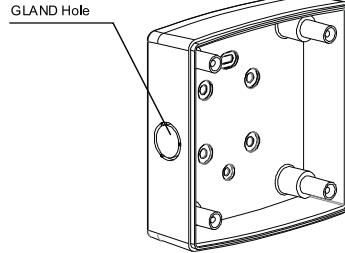
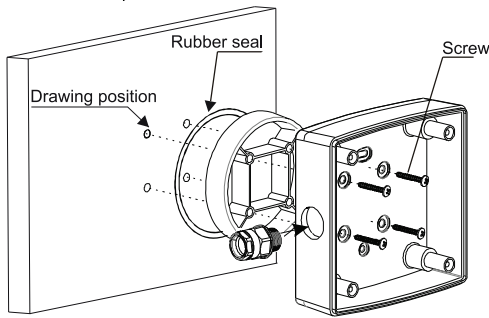

1) Select a suitable position to mount the loudspeaker. Offer the speaker to the wall or ceiling and mark through the mounting holes to position the fixing points to be drilled. Use a spirit level to ensure that the speaker will be level when fixed. Drill 4 fixing holes as shown in the diagram. Ensure you use the fixing holes that sit inside the rubber seal. The speaker can also be mounted to a standard single gang or BESA type back box. Use suitable raw plugs to secure the fixings.

2) Before fixing the speaker ensure it is correctly orientated to take the incoming speaker cable. The speaker can now be positioned over the fixing holes made in the mounting surface at Step 1. Ensure that the rubber "O" ring gasket and spacer ring is fitted as shown in Step 1. Then use suitable fixings to hold the speaker securely to the surface.

3) Terminate the speaker cabling into the terminal block via suitable cable glands. Select the correct tapping on the transformer located on the speaker front panel. Then fit the front panel to the back box making sure that the gasket is fitted correctly.

4) Once the speaker front panel has been fitted to the back box use the 4 screw fixings and washers supplied to secure the front panel. The speaker installation is now complete.

Frequency response

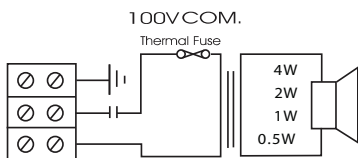
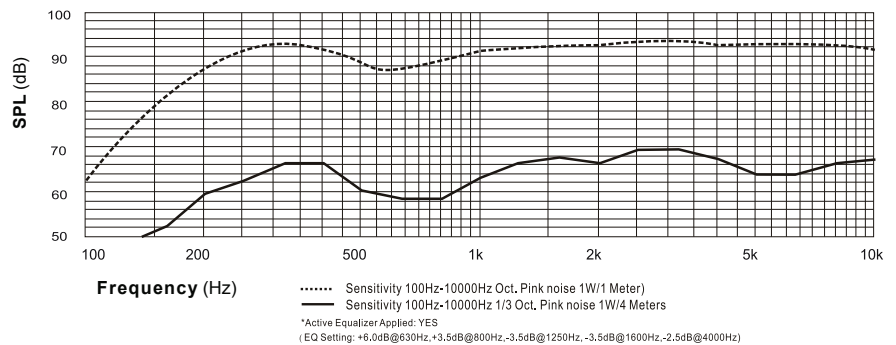

Circuit Diagram

Disclaimer: We reserve the right of changes and errors.



ATEIS Europe B.V.
 Celsiusstraat 1, 2652 XN Lansingerland, Netherlands
 Phone +31 (0)10 208 86 90, www.ateis-europe.com, info@ateis-europe.com

