

The SC-615BS is certified according to the European Standard EN 54-24: 2008, the International Standard ISO 7240-24: 2010 and in compliance with the British Standard BS 5839-8: 2008 14.8. DoP number is 20-005.

■ DESCRIPTION

The SC-615BS is the voice alarm certification product.  
 This speaker can be a clearer announcement for voice alarm.  
 The SC-615BS Paging horn speaker features an aluminum horn flare and stainless steel bracket for all weather durability.  
 The SC-615BS unique oval shape horn enhances excellent speech clarity.

■ SPECIFICATIONS

Rated Noise Power	15 W (100 V Line and 70 V Line)
Rated Impedance	100 V line: 670 Ω (15 W), 1 kΩ (10 W), 2 kΩ (5 W), 3.3 kΩ (3 W) 70 V line: 330 Ω (15 W), 670 Ω (7.5 W), 1 kΩ (5 W), 2 kΩ (2.5 W), 3.3 kΩ (1.5 W)
Sensitivity	109 dB (1 W, 1 m) (500 Hz - 2.5 kHz, peak level) ----- 100 dB (1 W, 1 m) (100 Hz - 10 kHz, pink noise) 88 dB (1 W, 4 m) (100 Hz - 10 kHz, pink noise)
Maximum Sound Pressure Level	110 dB (15 W, 1 m) (100 Hz - 10 kHz, pink noise) 98 dB (15 W, 4 m) (100 Hz - 10 kHz, pink noise)
Frequency Response	315 Hz - 12.5 kHz
Coverage Angle	Horizontal: 360° (500 Hz), 160° (1 kHz), 85° (2 kHz), 45° (4 kHz) Vertical: 360° (500 Hz), 200° (1 kHz), 115° (2 kHz), 60° (4 kHz)
Environmental Type	B (outdoor applications)
Operating Temperature	-20 °C to +55 °C (-4 °F to 131 °F)
Dust/Water Protection	IP65
Speaker Mounting Method	Wall-mount
Cable Gland	Size: PG 13.5 One cable gland is factory-installed. For bridge connection, one cable gland can be added.*
Applicable Cable Size	Outer diameter: ø8-12.5 mm Conductor: Solid wire or 7-core wire No bridge connection: 0.8 - 10 mm² (AWG18-AWG7) for solid wire, 0.8 - 8 mm² (AWG18-AWG8) for 7-core wire Bridge connection: 0.8 - 2.5 mm² (AWG18-AWG13) for solid wire, 0.8 - 1.5 mm² (AWG18-AWG15) for 7-core wire
Cable Connection	Screw terminal (steatite), can be bridge-connected
Finish	Horn flare: Aluminum, off-white, powder coating Reflector horn, Trans case, and Terminal cover: ABS resin, off-white Bracket, screws and bolts: Stainless steel
Dimensions	172 (W) × 195 (H) × 229 (D) mm (6.77" × 7.68" × 9.02")
Weight	1.5 kg (3.31 lb)
Accessory	Terminal cover--1
Option	Swivel bracket: YS-151S (Can be used instead of the supplied bracket.)

\*Suppliable cable gland's part cord and name: 525-52-011-70 Cable gland AVC PGB13.5-12 (GRY)

[Note] Never connect the 330 Ω position to the 100 V line.

■ APPEARANCE

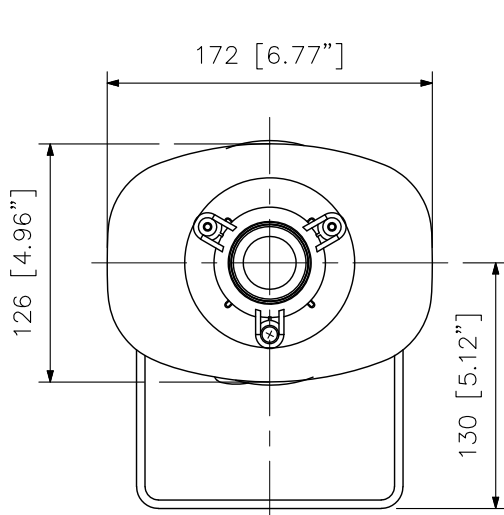

Front View

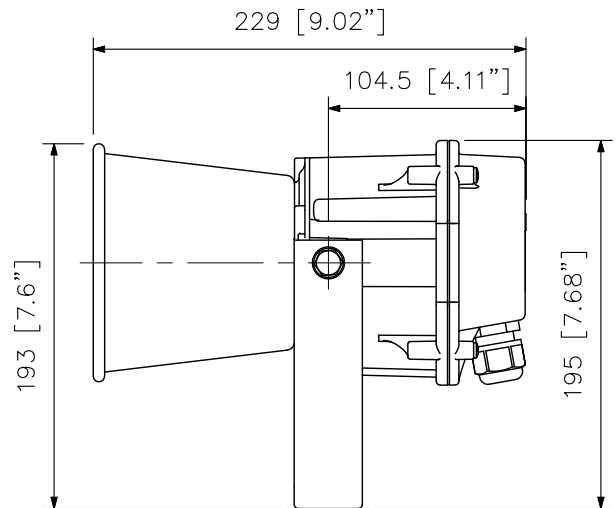

Side View

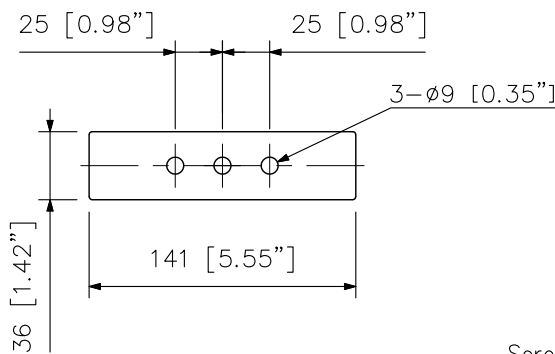

Dimensional Diagram

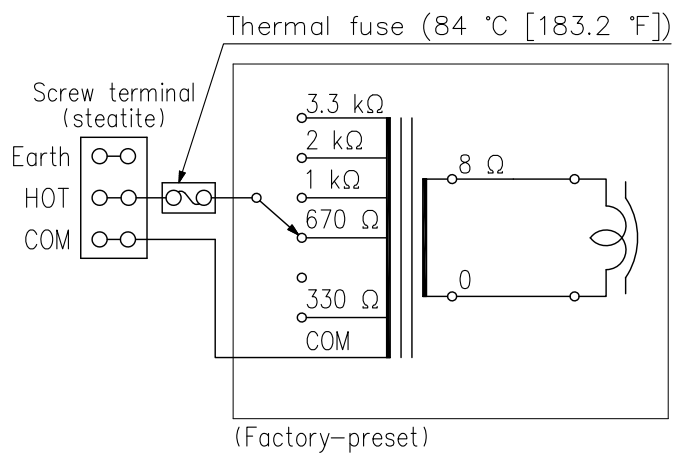

Wiring Diagram

UNIT:mm SCALE:1/4