

# ▶ Customised tank mixing systems



THE EJECTOR COMPANY

Tank mixing systems  
with liquid jet mixing nozzles

Applicable for many different mixing tasks

# Liquid jet mixing nozzles

Körting liquid jet mixing nozzles are the main components of tank mixing systems which can be applied for continuous as well as discontinuous mixing purposes. They can be used as complete replacement for mechanical agitators and in many cases they surpass their mixing results.

## WORKING PRINCIPLE

A liquid flow is taken from the tank and supplied to the liquid jet mixing nozzles via a pump. Inside the motive nozzle pressure energy is converted into kinetic energy. Negative pressure is generated at the motive nozzle outlet and the ambient liquid is sucked in.

The suction flow is strongly intermixed with the motive flow in the adjoining mixing section and accelerated by impulse exchange. The drag effect of the exiting mixed flow increases the mixing effect significantly.

Working principle of a Körting mixing nozzle

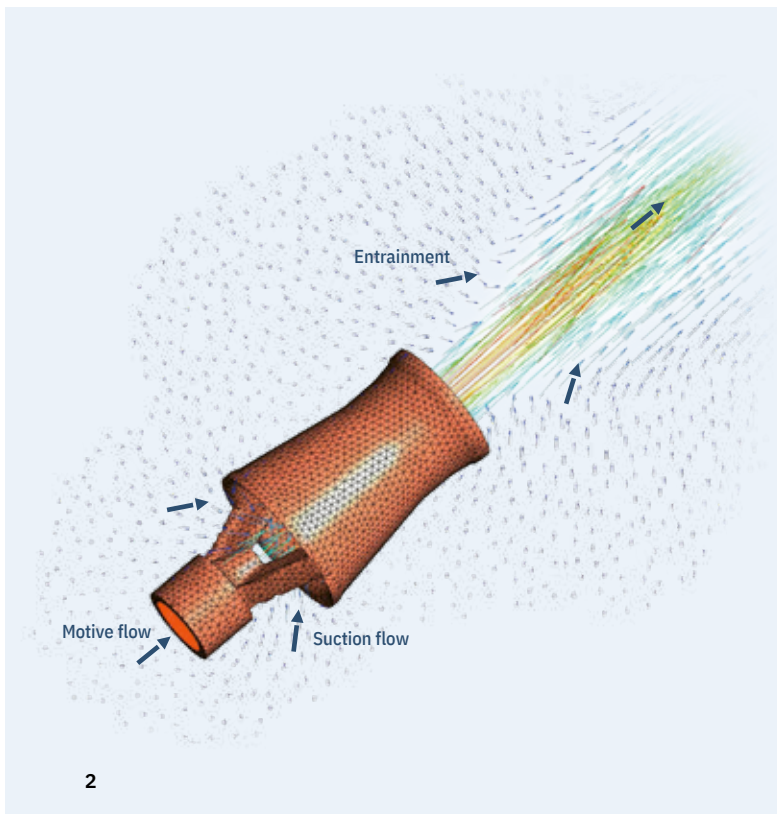

## ADVANTAGES OF KÖRTING TANK MIXING SYSTEMS

- low energy input
- no sealing problems
- low investment costs
- no unmixed dead zones
- wear-resistant operation
- no maintenance in the tank
- optimisation with (CFD) Computational Fluid Dynamics

## OPERATION

Mixing nozzles consist of a motive nozzle and a mixing section. The liquid motive medium introduced under pressure via the motive connection is usually taken from the tank and delivered into the liquid jet mixing nozzle by means of a pump mounted outside of the tank. In the motive nozzle the static pressure of the motive medium is converted into velocity generating a corresponding negative pressure at the suction openings which is utilised to draw in the so-called suction flow.

Suction and motive flow are intermixed intensively in this turbulent region at the motive nozzle outlet as well as in the adjoining mixing section and are subsequently supplied into the tank as mixed flow. The volume ratio between suction and motive flow is about 3:1. The mixed flow exits the mixing nozzle with relatively high velocity and encounters the liquid contained in the tank, which is subsequently entrained as a result of the mixed flow's drag effect, so that finally the sum of motive flow, suction flow and drag flow keeps the liquid inside the tank moving. The volume ratio between entrainment and motive flow is between 12 - 80.

So with 1 m<sup>3</sup>/h pumped up to 80 m<sup>3</sup>/h are moved.

## APPLICATION PREREQUISITES AND LIMITATIONS

Motive flow and suction flow are mixed in the mixing section behind the motive nozzle, so that a homogeneously mixed liquid jet develops in the mixing section due to high turbulence resulting from motive and suction flow.

In case of liquids with physical properties like water, a mixing ratio of motive flow to suction flow is 1:3. On account of its velocity and of the dragging jet effect resulting therefrom, the mixed flow leaving the liquid jet mixing nozzle carries forward so much surrounding liquid that the used motive flow is multiplied. In case of liquids with higher viscosity the mixing ratio and the dragging effect are decreased.

The limiting range for applying liquid jet mixing nozzles is reached when the viscosity of the liquid to be circulated does not allow a delivery with centrifugal pumps anymore. The motive flow passed through the liquid mixing nozzles of a certain size depends on the efficient motive pressure. If the motive liquid is removed from the mixing

tank this efficient motive pressure is to be equated with the delivery head of the centrifugal pump after deduction of all pipe friction losses.

In case where the motive liquid is not to be removed from the mixing tank the liquid column above the liquid jet mixing nozzles outlet is to be taken into account for determining the efficient motive pressure.

**Tanks from 1 m<sup>3</sup> to 100.000 m<sup>3</sup> can be equipped.**

Liquid jet mixing nozzles are suitable for all kind of tanks:

- storage tanks, e.g. for edible oil, fuel, oil, waste water
- reactors
- neutralisation tanks
- SBR tanks
- as discharge support

Size	Metals		Polymers	
	Stainless steel	GJS	PP	PTFE
G 3/8	•	•	•	•
G 3/4	•	•	•	•
G 1-1/2	•	•	•	
G 2	•	•	•	
G 3	•	•	•	

- Available from stock. All other materials and different sizes on request.

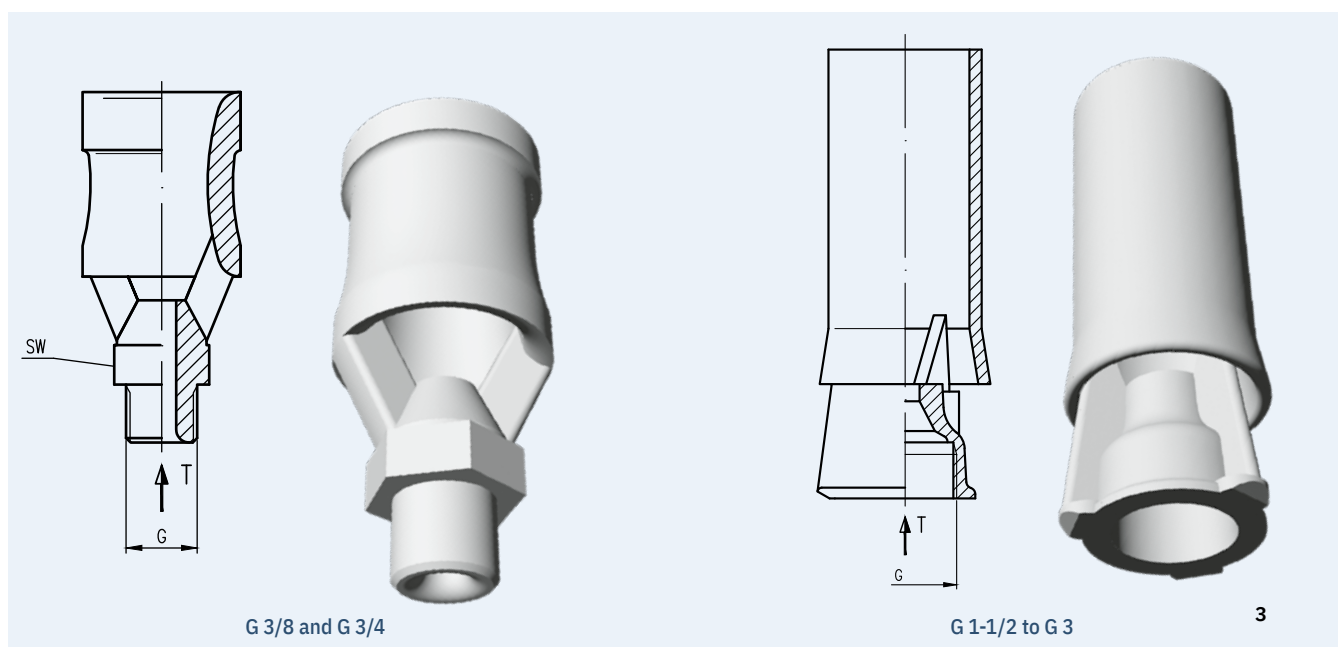

# Structure and function of tank mixing systems

The aim of Körting Hannover GmbH is to design customised tank mixing system solutions for each specific tank. The purpose of the tank mixing system is to generate a liquid circulation of the whole liquid volume which leads to complete mixing and prevents sedimentation. A guided directional flow will be generated by the mixing system. Therefore, flow velocities occur, which are higher than the sinking velocities of the particles in the liquid, so that settlement is avoided. The two examples in the figures below illustrate the principle of tank mixing systems.

The specific number of liquid jet mixing nozzles resulting from the tank mixing system dimensioning will be placed on two pipes close to the tank bottom and the tank wall. These two pipes follow the shape of the tank. For a round tank the pipes are semicircular whereas for a rectangular tank the pipes are straight. The required motive flow is supplied to the liquid jet mixing nozzles via these pipes. The motive flow pipes are situated oppositely to each other at two sides in the tank. Supply pipes can either be fixed on the tank wall or on the tank bottom. Pipe dimensioning will be according to normal flow velocities in order to keep the friction losses inside the pipes low. The size of each mixing nozzle, its alignment, e.g. the installation angle as well as the distance from one nozzle to another, are further results of the dimensioning.

One nozzle row will point alongside the tank bottom to generate the necessary flow velocities alongside this

area. At the opposite side of the tank the second nozzle row points upwards which generates an upward flow alongside the tank wall. By means of this guided directional flows the whole liquid volume is moved. In order to save energy at low filling levels the nozzle row pointing upwards can be switched off.

Dependent on the properties of the liquid to be mixed every different nozzle size has a certain range with regard to the liquid to be moved. For very large tanks it may be necessary to place further nozzle rows in the middle of the tank bottom in order to generate the required flow velocities to cover the whole distance. In case of very high tanks the nozzle row pointing upwards may be positioned higher above the tank bottom to achieve optimum mixing of the whole liquid.

**With the options of choosing different nozzle sizes, adjustment of nozzle rows according to the tank shape, modification of the nozzle distances and of being flexible concerning the operation of the different nozzle rows Körting Hannover GmbH is able to dimension the optimum tailor made tank mixing solution for every specific purpose. E.g. for full homogenisation, for prevention of settlements, for prevention from different temperature layers or for complete mixture of different liquids.**

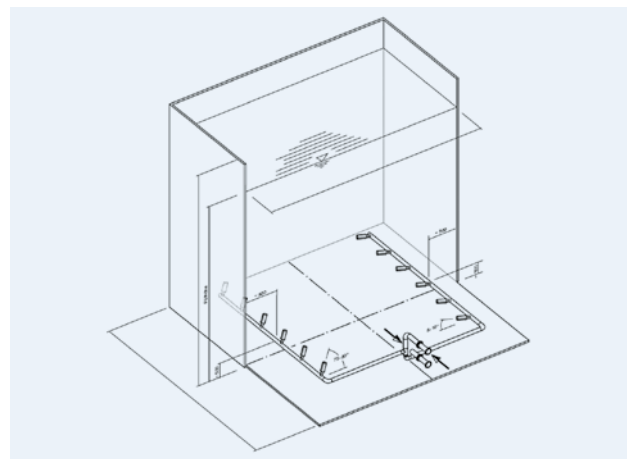
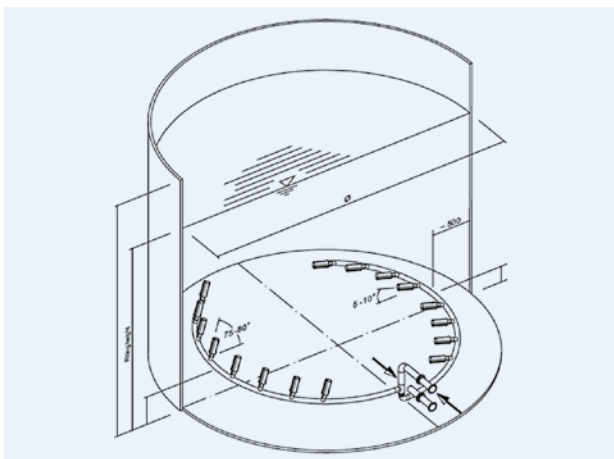

## PROPERTIES OF A TANK MIXING SYSTEM FOR EDIBLE OIL

The images below give a good impression of a complete tank mixing system in a storage tank for edible oil. 17 mixing nozzles made of stainless steel are installed nearly horizontally whereas 17 mixing

nozzles are installed nearly vertically at the opposite side of the tank. The tank volume is 11 000 m<sup>3</sup> with a filling height of 25 m and a diameter of 24 m.



### Technical data:

- cylindrical storage tank for edible oil
- 34 mixing nozzles of stainless steel 2"
- volume 11 000 m<sup>3</sup>
- height 25 m
- diameter 24 m

### Alignment of the mixing system:

The result of the Körting design is a sketch for the customer, which contains recommendations and information, so that the mixing system will be installed in the tank in an optimum way. In order to evaluate critical cases Körting Hannover GmbH uses CFD simulation ("Computational Fluid Dynamics").

## COST SAVINGS

The following example shows the potential of energy savings if applying a Körting tank mixing system:

### Tank dimensions

diameter	27.6 m
filling height	10 m
filling volume	5 983 m <sup>3</sup>

### Energy consumption

for mixing with conventional mixing system	10 W/m <sup>3</sup>
for mixing with Körting mixing system	4 W/m <sup>3</sup>
energy saving potential	6 W/m <sup>3</sup>

### Calculation

6 W/m <sup>3</sup> * 5 983 m <sup>3</sup>	35.9 kW (35 898 W)
35.9 kW * 8 760 h/a	314 484 kWh/a
314 484 kWh/a * 8.6 Ct/kWh	27 046 €/a

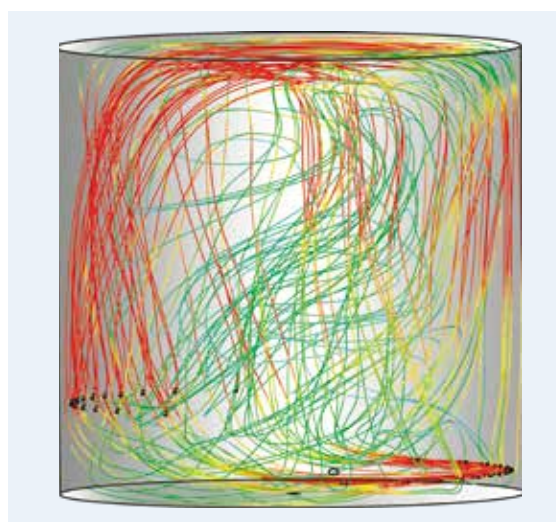

Optimisation of the flow conditions in a cylindrical storage tank for edible oil through three dimensional computer simulation. Vertical section; spatial distribution of the flow velocity as a coloured halftone image

The potential savings of energy costs are approx. 27 000 € per year.

\* 8.6 Ct/kWh = electricity costs for industrial customers in Germany, value for 2013

# CFD basics

When using the Computational Fluid Dynamics (CFD) model for mixing systems some helpful simplifications are used:

- steady state modelling (not transient)
- turbulent flow modelled with two equation turbulence model
- numerical grid with tetrahedral cells
- smooth liquid surface
- modelling of pipings and support plates, if required

## NUMERICAL FLOW SIMULATION

The aim of the numerical tests carried out is an optimum arrangement of the mixing nozzles inside the tank with regard to the a.m. design strategy. The tests are based on a liquid-filled tank.

Various combinations of flow medium and tank geometry can be optimised for customer specific tests per CFD by selecting corresponding physical material characteristics of the flow medium resp. special geometry requirements. The tank geometry to be tested is simulated by means of a CAD program. Digital geometry information of the individual mixing nozzles is imported directly from CAD systems used in the design process. Number, position and alignment of the simulated mixing nozzles inside the tank are determined, so that the complete tank configuration can be simulated digitally.

The whole simulated geometry consisting of all liquid jet mixing nozzles and the tank with pump connection is converted to a calculation grid by means of a so-called grid generator which is the basis of the CFD. The fluidic

## NUMERICAL SET-UP FOR A STORAGE TANK

height: 23 m  
 diameter: 68 m  
 mixing nozzles: 60 x 2"  
 tank volume: 80 000 m<sup>3</sup>



- generating a CAD file
- creating a numerical grid
- solving the conservation equations
- post process results

fundamental equations are solved for each of the cells generated within the grid.

Primarily, these are the conservation equations for mass, impulse and energy. Two further conservation equations will be solved in order to consider the turbulence caused by the liquids. All conservation equations are solved by means of the so-called equation resolver. In order to simplify the calculations they are based on stationary flow conditions. The whole simulation process from the grid generation up to the representation of the results takes place automatically for the most part.

On the one hand, geometrical boundary conditions for the simulation are the tank dimensions (filling height H, diameter D, length L, width W) as well as the position and size of the pump connections and on the other hand the number, position and alignment of the liquid jet mixing nozzles. Operational boundary conditions are determined by the motive pressure at the liquid jet mixing nozzle and the physical properties of the motive flow.

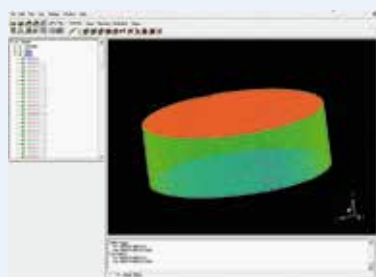

Geometrical set-up of the mixing system

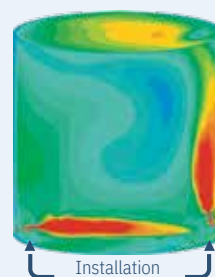

Optimisation of the liquid flow

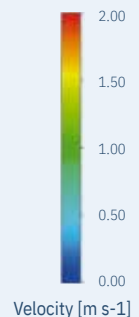

Velocity [m s<sup>-1</sup>]

**EXAMPLES OF CFD  
CALCULATION RESULTS**



**Edible oil tank**

height	30 m
diameter	19 m
mixing nozzles	32 x 2"
tank volume	8 500 m <sup>3</sup>
motive flow rate	790 m <sup>3</sup> /h
liquid density	910 kg/m <sup>3</sup>
liquid viscosity	35 mPas
mixing power	5.2 W/m <sup>3</sup>
average liquid velocity	0.17 m/s

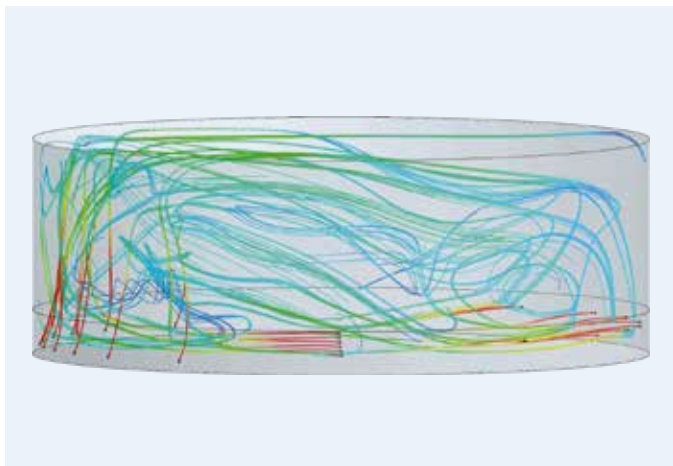

**Edible oil tank**

height	14.6 m
diameter	42 m
mixing nozzles	25 x 2"
tank volume	20 200 m <sup>3</sup>
motive flow rate	770 m <sup>3</sup> /h
liquid density	900 kg/m <sup>3</sup>
liquid viscosity	50 cpoise
mixing power	4.2 W/m <sup>3</sup>
average liquid velocity	0.09 m/s

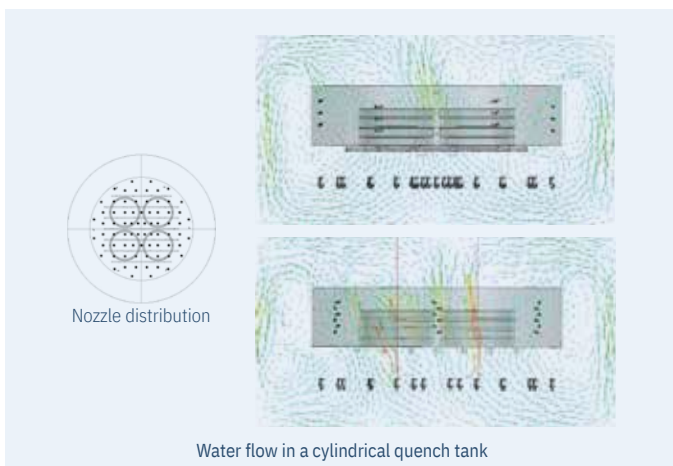

Water flow in a cylindrical quench tank

**Quench tank**

height	5 m
diameter	9.2 m
mixing nozzles	18 x 3/4" + 74 x 2"
tank volume	330 m <sup>3</sup>
motive flow rate	1 900 m <sup>3</sup> /h
mixing power	320 W/m <sup>3</sup>
average liquid velocity	0.8 m/s

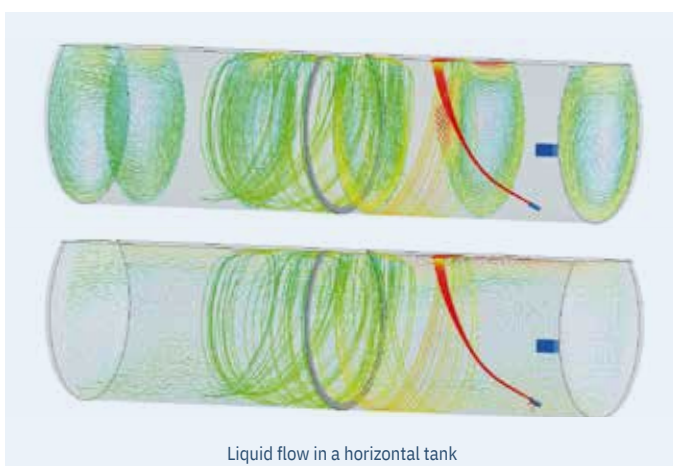

Liquid flow in a horizontal tank

**Fuel oil tank**

length	16 m
diameter	2.9 m
filling height	2.6 m
tank volume	60 m <sup>3</sup>
motive flow rate	12.8 m <sup>3</sup> /h
average liquid velocity	0.24 m/s



**Körting Hannover GmbH**

Badenstedter Str. 56  
30453 Hannover | Germany

+49 511 2129-221  
sales@koerting.de

**K O E R T I N G . D E**

