



Environmental  
protection with  
**swirl droplet  
separators**



THE EJECTOR COMPANY

Körting  
swirl droplet separators

The droplet separator specialists

# Swirl droplet separators

## HOW THEY WORK

Droplet separators play a key role in complying with emission regulations. As components in gas scrubbers (which are used to clean waste gas flows) they therefore help protect the environment.

Waste gas entering swirl droplet separators is cleaned by separating out the droplets. To achieve this phase separation, the gas flow is accelerated tangentially and rotated by a swirl generator. Three-dimensional vanes prevent inlet losses and stalls from occurring. Stable and consistent rotational flow forms in the adjacent helically coiled tube. Due to the centrifugal force, the droplets are thrust to the wall of the tube and collected there.

## BENEFITS OF KÖRTING SWIRL DROPLET SEPARATORS

- Superior separation efficiency (up to 5 µm)
- Low pressure loss
- Rinsing during operation
- Low maintenance
- Exceptional reliability and availability

Design of the swirl droplet separator

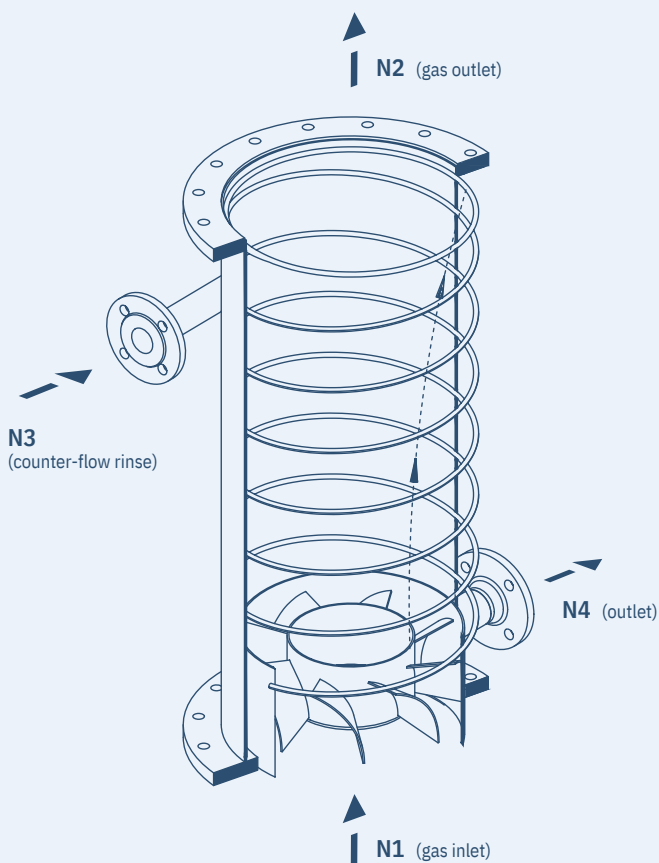

The separation chambers in Körting swirl droplet separators are designed as helically coiled tubes. This special design prevents the liquid film that forms on the tube wall from being conveyed to the gas outlet. The drag force of the gas has no impact on the separated droplets' flow. The liquid doesn't flow in the direction the gas rotates in, but downwards. This effect is achieved by the special profiles and layout of the helically coiled tubes that lead downwards towards the direction the gas rotates in. The liquid is collected and removed near the swirl generator.

The design also makes cleaning the inside of the helically coiled tube during operation easier. In complex applications, special additional rinsing systems effectively help to prevent deposits on the separator and on the swirl generator's vanes. This type is frequently required to separate challenging products where adhesion is a problem. Rinsing systems can be used while the machinery is in operation without generating new droplets in the scrubbed gas.

The swirl droplet separators are big enough so that large quantities of liquid, such as film forming on the walls and splashes, can be drained off too.

## MATERIALS

Körting swirl droplet separators are supplied in the following materials:

- Carbon steel, stainless steel
- Coated steel (rubber, Halar etc.)
- Plastic: fibreglass, PP, PVC, PVDF – reinforced and non-reinforced
- Special materials

## SIZES

Körting's swirl droplet separators are made in standard nominal diameters of DN 200 to DN 3,000. If you require other sizes, we'd be happy to draw up a quote tailored to your needs.

CFD simulation

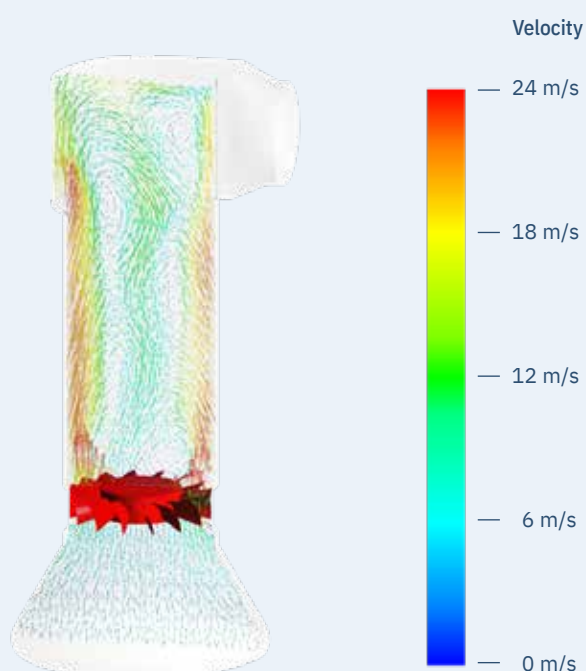

## APPLICATIONS

Körting swirl droplet separators are ideal for:

- Use in gas scrubbers and vacuum ejectors
- Removing condensate in flues
- Use in evaporators to ensure the vapour condensate is excellent quality
- To separate difficult products (that are prone to polymerisation for instance)

- 1) The film runs down the helically coiled tube
- 2) Droplets collect and form strands
- 3) The last visible droplets removed



## DESIGN EXAMPLE

A volume flow of **1,000 m<sup>3</sup>/h** is analysed.  
A nominal size of **DN 300** is selected.

The flow rate is shown in the diagram at the top. In this case, it's **c = 4 m/s**.

The pressure loss is shown in the diagram in the middle: **Δp = 2 mbar**.  
The best range to work with is generally between **3 mbar** and **5 mbar**.

The bottom diagram shows the critical limit drop. This is **10.5 μm** in the example selected.

All droplets with a diameter greater than this threshold are removed. However, only a smaller percentage (separation efficiency) of smaller droplets are drained off.



For a practical questionnaire to answer an enquiry for a quote quickly and further info, go to: [koerting.de/en/swirl-droplet-separator.html](http://koerting.de/en/swirl-droplet-separator.html)

## CHARACTERISTIC CURVES

DN 200 to DN 600

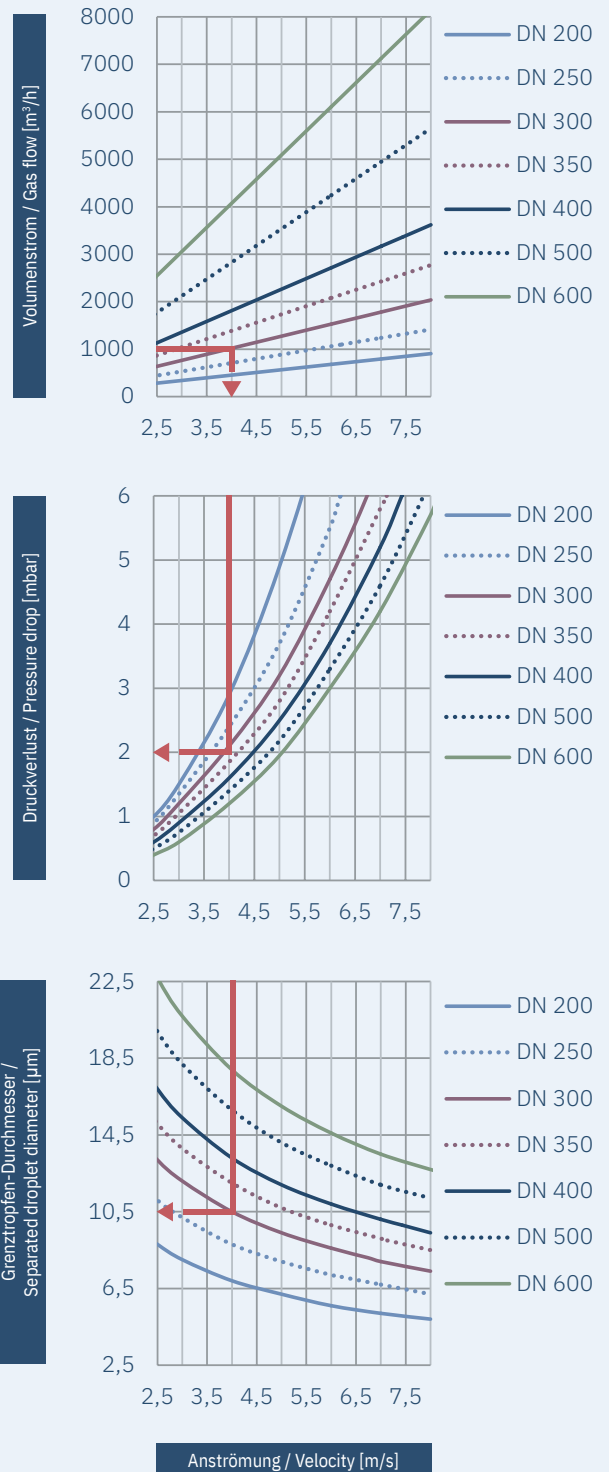

Applies to all diagrams: Air 30°C and 1,013 mbar

DN 700 to DN 1,400

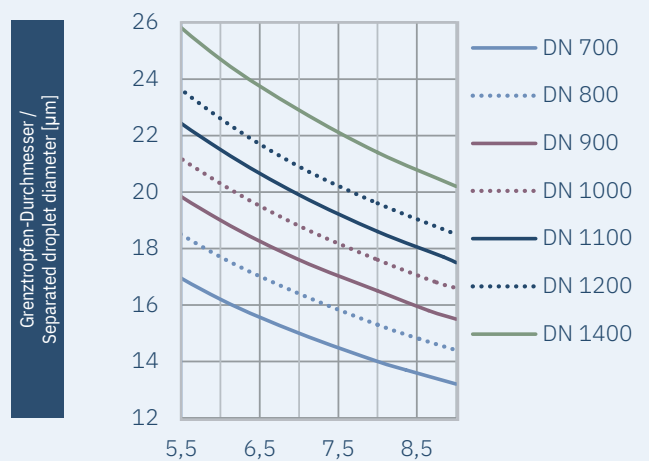
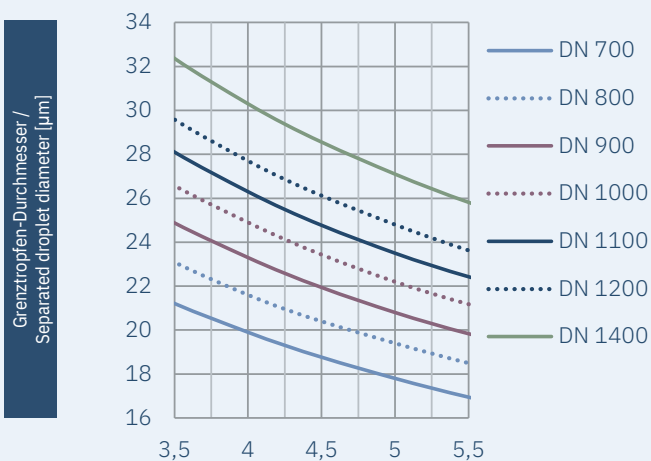
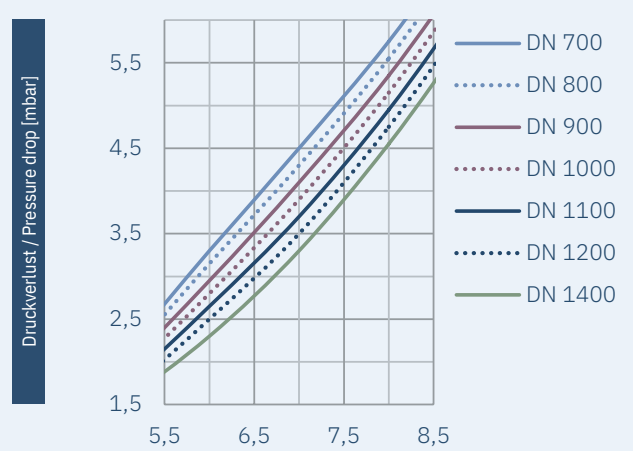
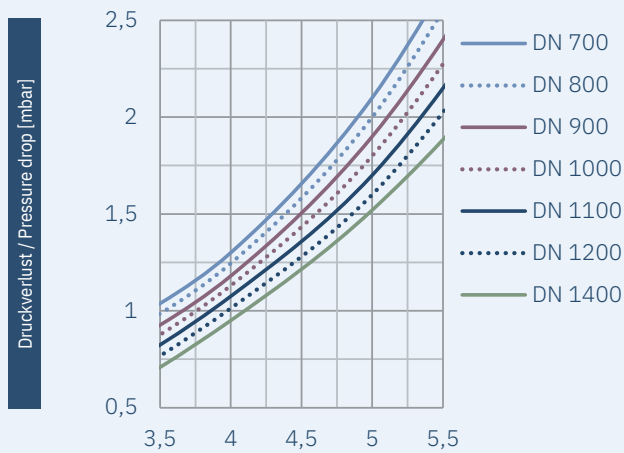
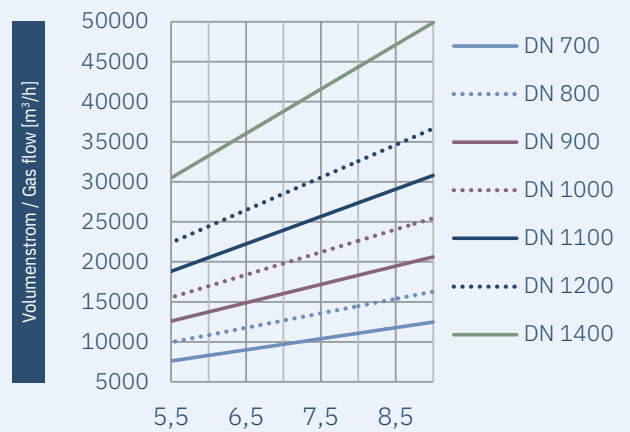
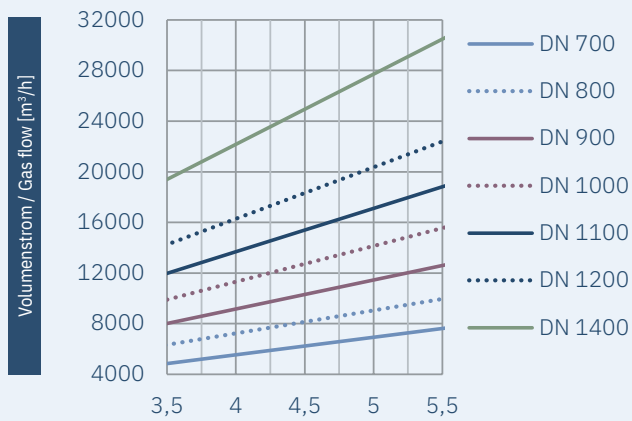

Anströmung / Velocity [m/s]

Anströmung / Velocity [m/s]

Applies to all diagrams: Air 30°C and 1,013 mbar

DN 1,600 to DN 3,000

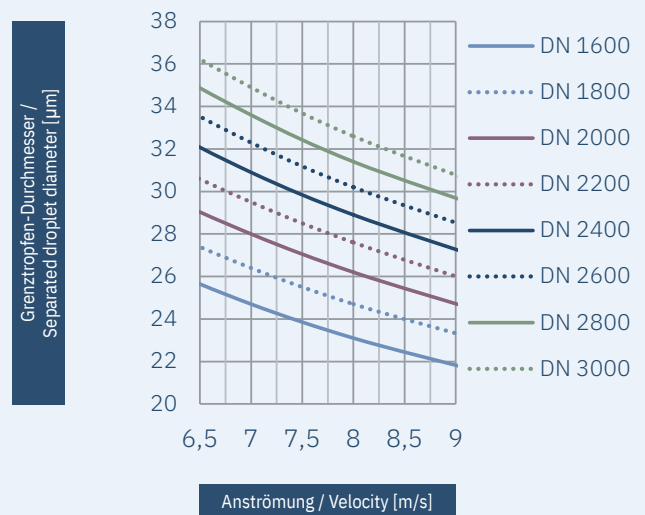
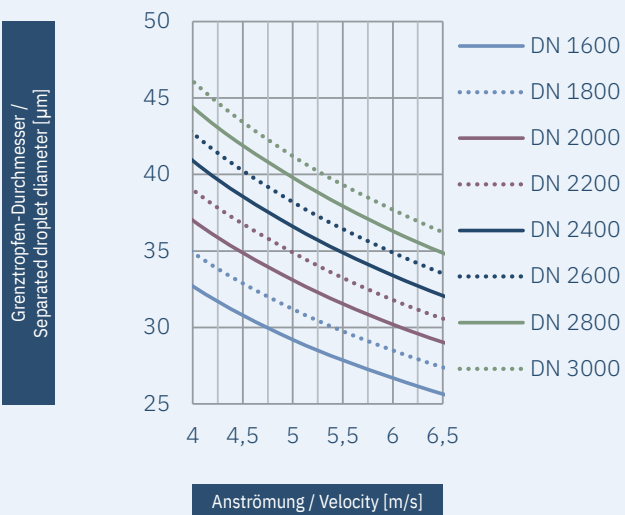
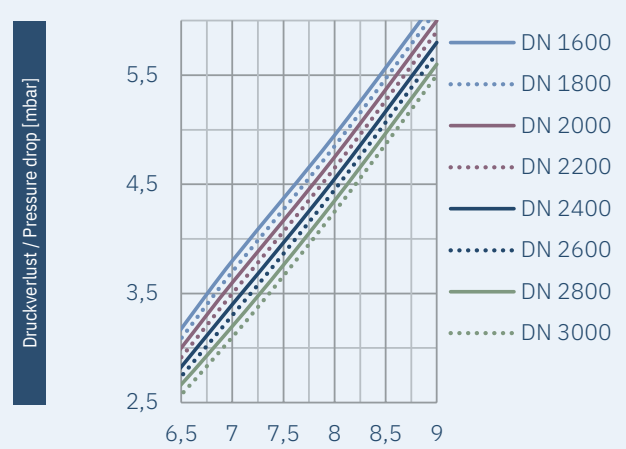
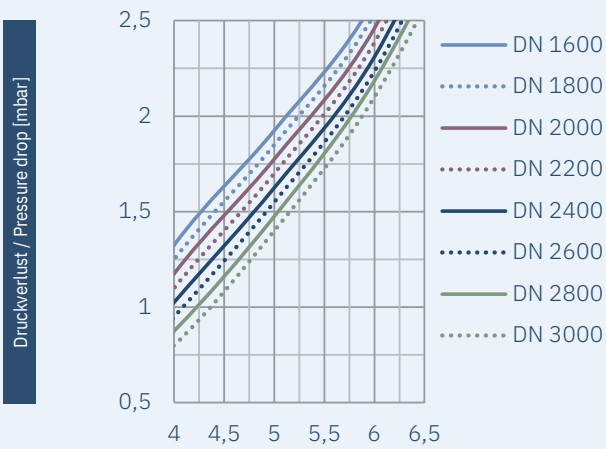
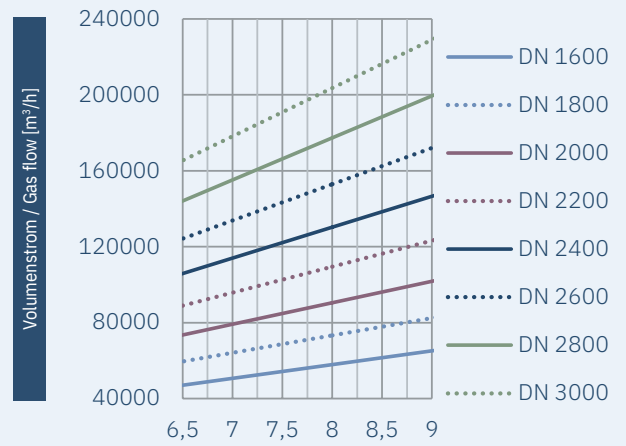
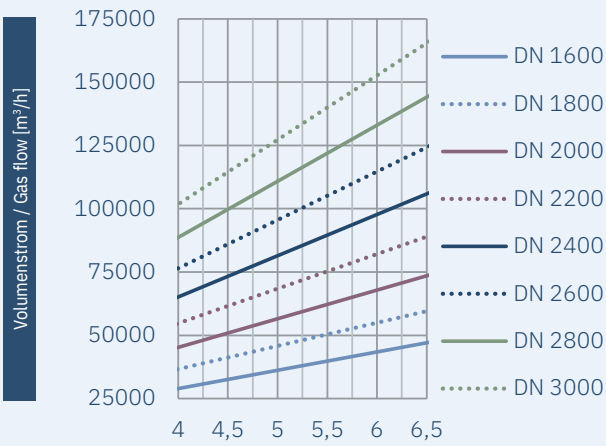

Applies to all diagrams: Air 30°C and 1,013 mbar

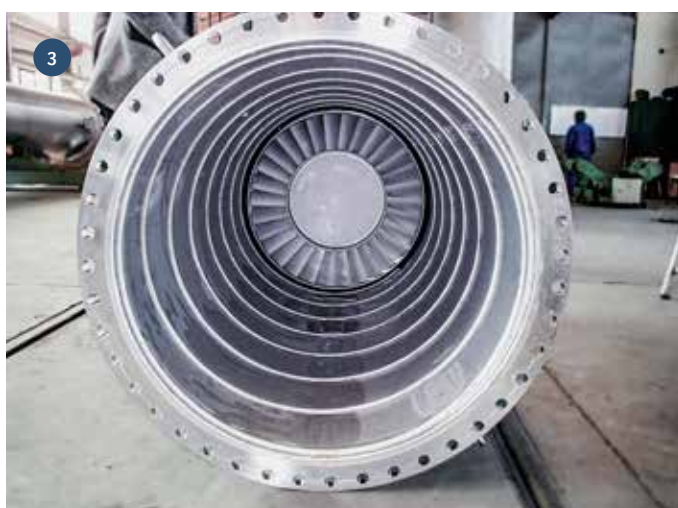
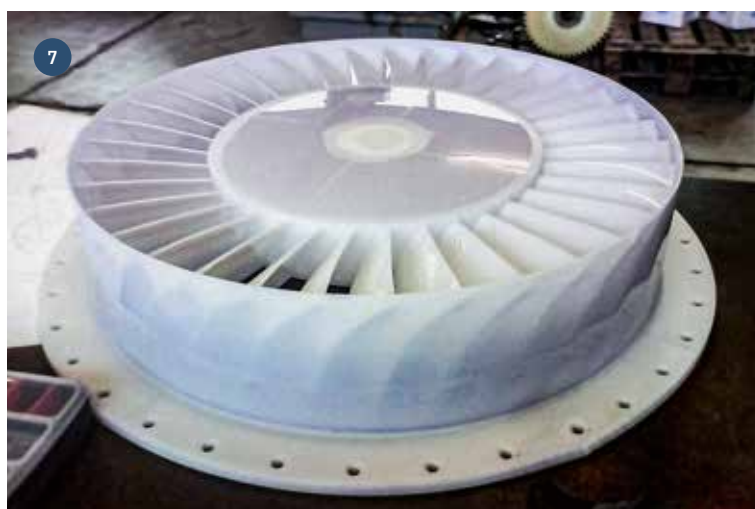

- 1) PVDF/fibreglass swirl droplet separator
- 2) Flue swirl droplet separator 3,000 for 290,000 m<sup>3</sup>/h
- 3) The inside of a helically coiled tube
- 4) Swirl droplet separator 200 with Halar coating
- 5) Flue swirl droplet separator
- 6) Flue swirl droplet separator
- 7) PVDF swirl generator
- 8) Swirl generator tube in tube



**Körting Hannover GmbH**  
Badenstedter Str. 56  
30453 Hannover | Germany

+49 511 2129-259  
sales@koerting.de

**K O E R T I N G . D E**



**ERIVAC KONSULT AB**  
INDUSTRIAL PROCESS ENGINEERING

Erivac Konsult AB  
Västra Sanddammsv . 5  
432 64 Bua | Sweden

+46 76 260-5875  
info@erivac.se

**ERIVAC.SE**

