

SARK100 SWR Analyzer

User Manual

Revision 0.5

Contents

1	INTRODUCTION.....	4
1.1	REQUIRED TOOLS	5
1.2	CREDITS.....	6
2	TERMS AND CONDITIONS	7
3	OVERVIEW.....	8
4	FEATURES.....	10
5	SPECIFICATIONS	12
6	KIT CONTENTS.....	13
7	ASSEMBLY GUIDE.....	17
7.1	PC BOARD PREPARATION	17
7.2	INSTALLING THE SURFACE MOUNT COMPONENTS.....	18
7.2.1	<i>Preparation for the job.....</i>	18
7.2.2	<i>Attaching the SMT components to the PCB.....</i>	19
7.3	INSTALLING THE TROUGH-HOLE COMPONENTS	22
7.4	POWER-UP AND TESTS.....	23
7.5	PREPARING THE ENCLOSURE.....	25
7.6	INSTALLING THE PCB IN THE ENCLOSURE	26
7.7	MANUFACTURING THE OVERLAYS	28
8	CONNECTIONS AND CONTROLS.....	30
9	ANTENNA ANALYZER OPERATION	31
10	USES FOR AN ANTENNA ANALYZER	37
10.1	ANTENNA MEASUREMENTS	37
10.2	MEASURE FEED POINT IMPEDANCE	37
10.3	MEASURE GROUND LOSSES	37
10.4	ADJUST ANTENNA TUNERS	37
10.5	CAPACITOR MEASUREMENT	37

10.6	INDUCTOR MEASUREMENT	38
10.7	MEASURE INDUCTOR Q.....	39
10.8	TRANSMISSION LINE CHARACTERISTIC IMPEDANCE	40
10.9	TRANSMISSION LINE LOSSES	40
10.10	TRANSMISSION LINE STUB LENGTHS	41
10.11	TRANSMISSION LINE VELOCITY FACTOR.....	42
11	PC SOFTWARE	45
12	PSOC DEVELOPMENT	47
13	TROUBLESHOOTING	49
13.1	SPECIFIC PROBLEMS.....	50
13.2	VOLTAGE CHARTS	51
14	THEORY OF OPERATION – HARDWARE	52
15	THEORY OF OPERATION – SOFTWARE.....	57
APPENDIX A:	SCHEMATICS	60
APPENDIX B:	PART LIST.....	63
APPENDIX C:	COMPONENT LAYOUT	64
APPENDIX D:	ENCLOSURE DIAGRAMS	66
APPENDIX E:	USB DRIVER INSTALLATION.....	71
APPENDIX F:	UPDATING THE ANALYZER SOFTWARE	72
APPENDIX G:	CALIBRATING THE ANALYZER.....	74
APPENDIX H:	MAKING A DUMMY ANTENNA FOR TESTING.....	76
APPENDIX I:	PC COMMAND INTERFACE.....	77
APPENDIX J:	QUICK REFERENCE SHEET	81

1 Introduction

The SARK100 SWR Analyzer is yet another antenna analyzer but available in kit form and designed to be easy to assemble and with an affordable pricing. You will enjoy of this DIY experience that it will not only help for improving your SMD soldering skills and learn about the analyzer basics but you will get a useful instrument for your shack. In addition you will have the possibility of modifying and updating the analyzer software via USB at your convenience, but even more, part of hardware is software configurable because of the programmable features of the PSoC micro-controller. For instance, you can change the ADC type, increase or decreasing the resolution or the sample rate, etc; therefore it is excellent training kit for the learning of the PSoC microcontroller.

This kit requires some soldering skills so I would not recommend it if it is your first experience with the soldering iron. In this case it is better starting with a kit based on through-hole components. If you have experience with the soldering iron but you are new to the SMD, don't be afraid, it is much easier that it seems using the correct technique and (basic) tools. It is a kit with a moderate component count so once you have completed I'm sure that you will be more confident to embrace the building of more complex SMD kits.

This manual includes everything you need to know about the SARK100, including the assembly guide, technical descriptions, operating guide, and detailed technical information including schematics and diagrams. Please visit the project website (<http://www.ea4frb.eu/sark100.html>) to access the updates and latest versions of software.

This kit is an amateur project developed in my spare time, and so no commercial backing possible. You should be aware of this and accept as is; otherwise you will find in the market a variety of finished products or similar kits. In any case I have made every reasonable effort to allow you having success with the assembly. Please do not hesitate to contact me to give me opinions about the kit or have questions. I thank you for buying the kit and I wish you luck in the construction and use!

Sincerely,

Melchor Varela, EA4FRB

melchor.varela@gmail.com

1.1 Required Tools

PCB Assembly

You will need the following tools to assemble the components to the board:

- Solder iron 25W (better if it has temperature control) and a moistened sponge
- Tweezers (recommended)
- Magnifying lamp (or magnifying glasses or loupe)
- Flat pliers and wire cutters

Test equipment

You will need the following equipment for the power-up and tests:

- DC Power source 13.8-19 V
- Multimeter
- Oscilloscope (helpful but not essential) or a RF probe

Tools for the enclosure preparation

You will need the following tools for the enclosure cutouts:

- Small slot screwdriver
- Hand drill
- Thin cutting fretsaw, file, and sandpaper
- 3 or 4mm drill bit for metal
- 13mm spade drill bit
- 13mm drill bit for metal
- Contact glue

Tools for building the overlay

If you decide making the covers using the procedures described in this manual you will need the following:

- Inkjet printer
- Photo paper A4 size, preferably sticker type
- Transparent glue (in case of not using sticker paper)
- Cutter
- Rule
- Acrylic spray lacquer used for modeling or decoration

Other

The following components are not supplied with the kit but will be required for its operation:

- 8 Batteries NiMH 1000mAh capacity and AAA size
- USB Mini-B Cable

1.2 Credits

- Special thanks to Antonio, EA1CDV, for his great help and collaboration in the project development and diffusion
- Cypress Semiconductor for providing a development kit for PSoC
- Many ideas for this project are based on Micro908 project of AmQRP Club, which has been an excellent design reference as well as documentary
- Dan Maguire AC6LA by Excel sheet ZPlots
- Andrew Smetana by the application note "Bootloader: PSoC"

2 Terms and Conditions

1. The supply of the SARK100 is subject to the following Ordering Terms and Conditions:
2. This kit is an amateur project developed in my spare time, and so with no commercial support. You should be aware of this and accept as is; otherwise you will find in the market a variety of finished products or similar kits.
3. You should satisfy yourself whether the product meets your specific requirements, prior to placing an order. You must also ascertain whether you have the appropriate skills to assemble and operate the product.
4. Orders and Payment submitted by email and/or Paypal should include a confirmation of your acceptance of these Ordering Terms and Conditions. Payment shall be made via Paypal or via another agreed method.
5. I will respond within 3 working days with an email with information on acceptance of your order and expected shipping date.
6. It is reserved the right to modify or withdraw any product including pricing without giving prior notice.
7. It is warranted that unless stated otherwise, all products are new and sourced from reputable suppliers. Any missing parts should be notified within 90 days from date of shipment.
8. It is not accepted any responsibility for kit assembly errors, for repairs due to non-operation, misuse, inadequate kit-building skills, unauthorised product modification or lack of performance.
9. It will be made all reasonable efforts to investigate and resolve systematic products issues reported by multiple users.
10. Software or firmware is provided "as is" and no warranties or indemnities are made. Reasonable endeavours shall be made to fix reported systematic product issues.
11. Liability of shall be limited to the amount paid for the product. No liability is accepted for either indirect or consequential damages which may be attributed to the supplied product.
12. The supplied kit is designed and made available primarily to Educational, Amateur Radio and Hobbyist use. No warranties are made whatsoever as to the stability and suitability of the design in extended periods/continuous operation or operation outside components' specifications. No liability is accepted for accuracy of measurements or performance either short term or long term.
13. The intellectual property including printed circuit boards, software or firmware, product and kit assembly manuals remains property of the author and does not transfer the buyer through the sale of the product. Commercial reproduction and reverse engineering is strictly prohibited.

3 Overview

The SARK100 SWR Analyzer Kit is a measurement instrument which determines antenna system performance across the HF/6M amateur bands without the need of connecting the transmitter to the antenna. It is ideal for checking the resonance, bandwidth, and SWR in an easy and fast way. The meter also measures the resistance, reactance, and the magnitude of the impedance.

The analyzer is comprised of a single double-sided printed circuit board PCB (145mm x 81mm) containing all components, controls, and a 2x16 LCD display with backlight; all inside an enclosure that allows in-hand use. The enclosure holds an 8-cell AAA battery pack enabling convenient field use.

The analyzer design is based on a DDS signal generator, a PSoC microcontroller, and a reflectometer for the impedance measurements. The features and flexibility of the PSoC microcontroller allows for a simple hardware design. The design provides an USB interface to allow FW updates and uploading of the real-time measurements to the PC. The development environment is the free PSoC Designer tool and the code has been programmed in 'C' language allowing along the USB update capability the easy customization of the code without the need of acquiring any tool.

The figure below illustrates the block diagram of the analyzer:

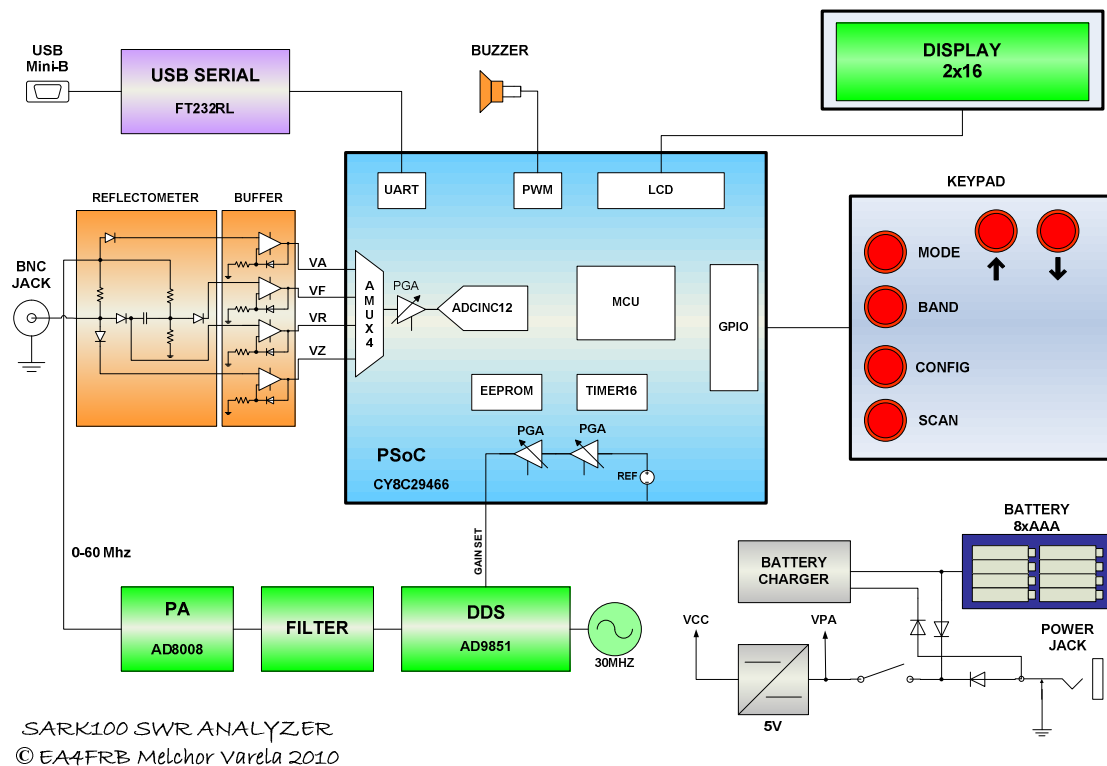

Figure 1, Block diagram

The DDS, filter, and power amplifier form a sinusoidal signal generator which frequency and amplitude is controlled by the PSoC micro-controller. The amplitude control allows compensating the roll-off effect of the digital to analog converter in the DDS. The signal generator signal is delivered to the antenna through a reflectometer consisting of an absorptive SWR bridge using matched diode detectors and compensated buffer amplifiers. The data provided by the reflectometer are digitized and used by the micro-controller to compute the SWR and impedance values for each sampled frequency.

The user iteration is provided by a 2x16 display with backlight, a keypad, and a buzzer. In SCAN mode the micro-controller sweeps the signal generator in the selected band looking for the minimum SWR point, the resonant frequency, and the 2:1 SWR limits in order to determine the 2:1 bandwidth. At the end of the scan the resonance frequency is selected and it is shown the impedance values. In manual mode the frequency and bands can be selected using the keypad and allows selecting four operating modes: SWR, complex impedance, capacitance, and inductance.

The analyzer is able to determine the sign of the impedance by a frequency shifting technique. It takes the measure of the reactance at the selected frequency and compared with the value of the reactance at a frequency slightly higher. In the case that the value of the reactance is greater it is likely that the reactance be inductive (+ j). If the case that value of the reactance is less it is likely that the reactance be capacitive (-j).

The analyzer is designed to be field-usable and operating friendly. It has a convenient form-factor for hand operation and the push-button controls are positioned along the left top side of the unit. The RF connector is located at the top of the unit to provide a convenient connection to the antenna being measured. The external power jack, the USB connector, and the power switch are located in the bottom side of the instrument.

The unit provides both operation from the internal batteries or from an external power adapter. The analyzer software implements some power saving features in order to extend the battery autonomy. The internal batteries are charged automatically by a constant current battery charger when the external power adapter is connected.

4 Features

- Automated antenna SWR analyzer
- Supplied as an easy to assemble kit at an affordable cost
- Hardware:
 - Powerful and flexible PSoC microcontroller to control instrument operation
 - Precise and self-calibrating reflectometer design measures forward and reflected signals and impedance data
 - Display 2x16 with optional backlight
 - Precision DDS signal generator (AD9851) used as signal source
 - USB port connects to PC for field-upgradeable software and uploading of real-time measurement data
 - Buzzer
- Software:
 - Microcontroller software programmed in 'C' language
 - Open source GPL license
 - Free PSoC Designer tool and field-upgradeable capabilities allow user customization of the analyzer operation
- Operation:
 - Manual control option displays SWR and complex impedance at selected frequencies
 - Automatic scanning results displayed as frequencies of lowest SWR and complex impedance
 - Battery operated for field use or use external 13.8V wall adaptor
 - Power saving modes
 - Multi-point calibration for better accuracy

- Instrument Capabilities:
 - Measure antenna electrical parameters: SWR, impedance (resistance + reactance), capacitance, inductance
 - Measure feedpoint impedance
 - Measure ground loss
 - Adjust antenna tuners and determine loss
 - Measure inductors and capacitors
 - Measure coax transmission line (SWR, length, velocity factor, approximate Q and loss, resonant frequency, and impedance)
 - Measure and determine optimum settings for tuning stubs: SWR, approximate Q, resonant frequency, bandwidth, impedance
 - Determine characteristic impedance of transmission line
 - Determine length of $\frac{1}{4}$ and $\frac{1}{2}$ wave phasing lines
 - Coaxial Cable Loss
 - Determine antenna tuner loss
 - Measure balun loss
 - Measure inductor Q
 - Estimate quartz crystal parameters
 - Measure magnetic loop resonance and SWR

5 Specifications

- Frequency Generation & Control:
 - 1 - 60 Mhz
 - Source impedance: 50 Ohms
 - Stability: +/- 100 ppm
 - Spectral Purity: Harmonics down >- TBD dB beyond 60 MHz
 - Step Size: User configurable increments of 100 Hz, 1 kHz, 10 kHz, and 100 kHz

- Usable Measurement Range:
 - SWR: 1.0 to 9.99
 - Impedance: approx. 5 to 2000 ohms

- RF Output:
 - Adjustable: 2.0 Volts pp (typ)

- Power supply:
 - External: 13.8 to 19 Volts DC, 500mA
 - Internal: 8xAAA 1000mAh NiMH cells
 - Charging time: 12 hours (charge rate 0.1C)

- Controls:
 - Pushbuttons (5): "Mode", "Band", "Config", "Scan", "Up", "Down"
 - Switch: "Power On"

- Connectors:
 - RF Out: BNC
 - USB: Mini-B receptacle
 - External power: 2.1mm Power Jack (center pin positive)

6 Kit Contents











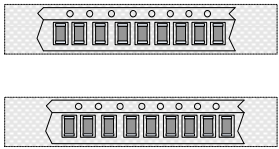
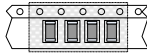

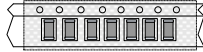

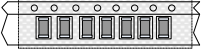



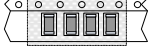



The SARK100 kit consist of a double sided printed circuit board with silkscreen and solder mask, the components including the pre-programmed PSoC microcontroller, soldering supplies, and a suitable instrument box in grey colour (supplied without machining).

Carefully review the contents of each parts bag and component supplied in the kit to ensure that you have everything needed at the start of the project. If a part is missing, please contact me by email and we'll get it out to you right away.

The components are provided in individual bags including the label with their complete identification including the reference that is used for identifying the component on the printed circuit board silk-screen.



The passive components: resistors, capacitors, and inductors are supplied attached to cards as shown on the next page:

<p>0.1uF C1,C2,C3,C4,C5,C6,C7, C8,C14,C15,C16,C17,C 27,C28,C31,C35,C37,C 40</p> 	<p>47K R26,R32,R35,R38</p> 
<p>15pF C9,C10</p> 	<p>49.9Ω R27,R28,R30,R9,R12, R13,R17</p> 
<p>47pF C11</p> 	<p>1M R29,R33,R36,R39</p> 
<p>100pF C12,C30, C19, C21, C22, C25</p> 	<p>12Ω R43</p> 
<p>82pF C13</p> 	<p>10Ω R44</p> 
<p>1uF C18,C29,C36,C39</p> 	<p>4.7K R52</p> 
<p>0.01uF C20,C23,C24,C26</p> 	<p>10K R53,R54</p> 
<p>10uF C38</p> 	<p>470Ω R15</p> 
<p>0.10uH L1,L2</p> 	<p>680Ω R16</p> 
<p>3.9K R3</p> 	<p>100K R24,R25</p> 
<p>1K R4,R8</p> 	<p>220K R31,R34,R37,R40</p> 
<p>200Ω R10,R11,R18</p> 	<p>2.7K R22</p> 
<p>24Ω R14</p> 	

SARK100 Parts List:

Cantidad	Referencia	Descripción
1	PCB	Double-sided printed circuit board, including solder-mask and silkscreen
1 m	SN	Thin solder wire
1	FLUX	Solder flux pen
10 cm	WICK	1.5mm solder wick
1	CASE	Grey ABS Enclosure with aluminium panels
4	SCREW CASE	PCB Screws
1	U4	Pre-programmed CY8C29466-24PXI
1	OVL	Drilling guide self-adhesive paper
1	LCD	Display 2x16 with backlight
1	RT-50	Calibrating resistor 49.9 Ω
1	RT-150	Calibrating resistor 150 Ω
1	RT-274	Calibrating resistor 274 Ω
1	U6 Heatsink	TO220 Heatsink, including screw, washer, and bolt
1	U9 Heatsink	TO220 Heatsink, including screw, washer, and bolt
18	C1,C2,C3,C4,C5,C6,C7, C8,C14,C15,C16,C17, C27,C28, C31, C35, C37, C40	0.1uF
2	C9,C10	15pF
1	C11	47pF
6	C12,C30, C19,C21,C22,C25	100pF
1	C13	82pF
4	C18,C29,C36,C39	1uF
4	C20,C23,C24,C26	10nF
1	C38	10uF
4	D1,D2,D3,D4	HSMS-2805
3	D5,D6,D7	B340A-13-F
1	JP1	HEADER 16
2	JP2	BATTERY HOLDER
0	JP3	DON'T ASSEMBLE
1	J1	BNC JACK
1	J2	MINI B USB
1	J3	POWERJACK
1	LS1	BUZZER
2	L1,L2	0.1uH
2	Q2,Q3	2N7002/SOT
1	R3	3.9K
2	R8,R4	1K
7	R9,R12,R13,R27,R28, R30,R17	49.9
3	R10,R11,R18	200
1	R14	24
1	R15	470
1	R16	680
1	R22	2K7
2	R25,R24	100K

Cantidad	Referencia	Descripción
4	R26,R32,R35,R38	47K
4	R29,R33,R36,R39	1M
4	R31,R34,R37,R40	220K
0	R42	DON'T ASSEMBLE
1	R43	12
1	R44	10
2	R53,R54	10K
1	R52	4.7K
0	R48,R49,R50,R51	DON'T ASSEMBLE
6	SW1,SW2,SW3,SW4, SW5,SW6	SW PUSHBUTTON
1	SW7	SWITCH POWER
1	U1	AD9851BRSZ
1	U2	AD8008ARZ
1	U3	OSC-30MHZ
1	U5	TLC279/SO or LMC6484IM
1	U6	L7805
1	U8	FT232RL
1	U9	LM317
1	U10	SURGE ARRESTER 75V
1	U11	MC7812

⚠ Note: following components are not supplied and it is not necessary assembling them:

- JP3, R42, R48, R49, R50, R51

⚠ Solder Flux can be supplied in a pen form or a bottle (15ml) with an application brush:



7 Assembly Guide

The assembly of the kit consists of several stages. The first step is assembling the components on the printer circuit board. The assembly of the board is not as difficult as may seem at a first glance and can be performed without difficulty using the right tools. The complete assembly of the board should not take more than four hours. After this you will be ready for the power-up and tests phase.

Then it will be necessary preparing the enclosure before the assembly of the board. For that purpose it is supplied the cutting patterns printed on a sticker paper that have to be affixed to the enclosure and panels and it will greatly help to make the cuts. Once the enclosure is machined, you will assemble the board and the battery holders. The preparation of the enclosure and the assembly operation should not take more than three hours.

Finally you can optionally build the instrument overlays for a better product look. In this section I will show you a homebrew method for building the overlays using an inkjet printer.

7.1 PC Board Preparation

You should become familiar with the orientation nomenclature that we'll be using throughout this manual, see the following illustrations:

Top, "Components" Side

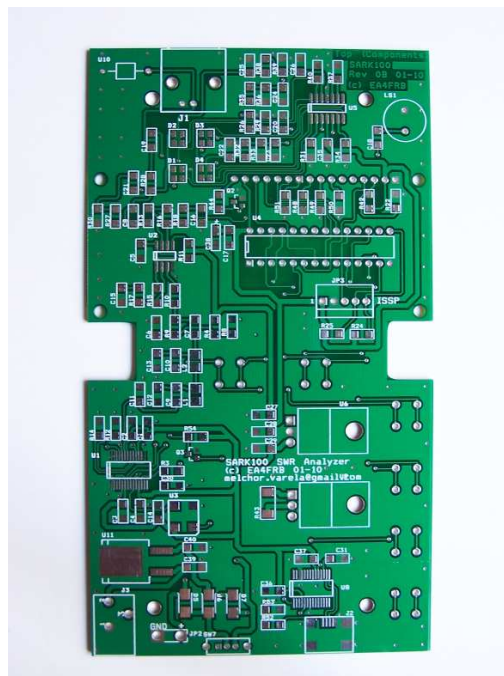

← Left

Right →

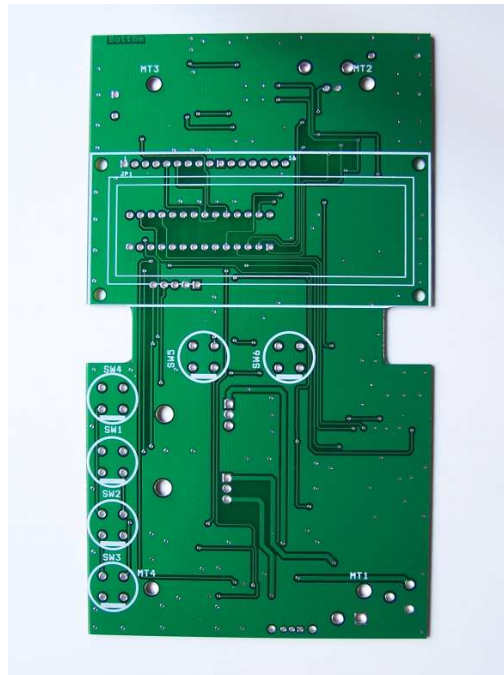
Bottom, “Controls” Side

← Left

Right →

7.2 Installing the surface mount components**7.2.1 Preparation for the job**

The key to being successful with any construction project is selecting and using the proper tools. For projects using SMT (Surface Mount Technology), the tools are easy to find. A magnifying lamp (or magnifying glasses) is essential for well-lighted, close-up work on the components. Tweezers or fine-tipped pliers allow you to grab the small chip components with dexterity. Thinner solder (.015”) than you might normally use is preferred because of its being quicker to melt and smaller in solder volume on the component lead. Use of a fine-tipped soldering iron makes soldering the leads of these small parts straightforward and easy. The solder flux and the solder wick are key for the success of the soldering of SMT components. Both solder, flux, and the solder wick are included in the kit.



A clean work surface is of paramount importance because SMT components often have a tendency to fly away even when held with the utmost care in tweezers – you'll have the best chance of recovering your wayward part if your table is clear. When the inevitable happens, despite your best efforts of holding an SMT part in your tweezers, you'll have lots of trouble finding it if it falls onto a rug-covered floor. It's best to have your work area in a non-carpeted room, for this reason as well as to protect static-sensitive parts.

7.2.2 Attaching the SMT components to the PCB

I recommend starting for the surface mount integrated circuits and in the following order: U11 (regulator), U5 (operational amplifier), U3 (oscillator), U2 (amplifier), U1 (DDS), U8 (USB driver), and J2 (USB connector). Be first especially observant of the component orientation stenciled on the PCB. Apply solder flux to the component pads then pre-solder the pad in one corner of the given layout and after that carefully position the leads of the IC over its set of pads on the PCB. You can use your fingers to carefully align the IC over all its pads and then reheat the corner pad to reflow the solder onto the IC pin. This should leave the IC attached by that pin.

Again making sure the IC pins are aligned over all pads, carefully solder the opposite corner lead to its pad. This should leave all other pins of the IC aligned over their respective pads, making it easier to solder them. Then apply again the solder flux on the component pads. Next solder each of the other pins to their respective pads, being careful not to bridge solder across any adjacent pads or pins. If this happen, no problem! Just grab some solder wick and use it to draw off the excess solder, which should be fairly easy and clean because of the solder-mask on the PCB.

Once you completed this the attaching of the following components will be a piece of cake. The resistors and capacitors are provided in a comfortable 1206 size, and only Q2 and Q3, and D1-D4 have a smaller (but still manageable) size. First you must be careful with the orientation of D1, D2, D3, D4, D5, D6, D7, and C38. The diodes D1, D2, D3 and D4 have a pin wider than the others. This should match the notch marked on the silkscreen, i.e., facing the bottom of the board. The diodes D5, D6, and D7 have a white band that points to the cathode, which must be

mounted with the cathode pointing to the bottom of the board, i.e. pointing to SW7. The band indicator in C38 signals the positive polarity, marked with the '+' in the silkscreen.

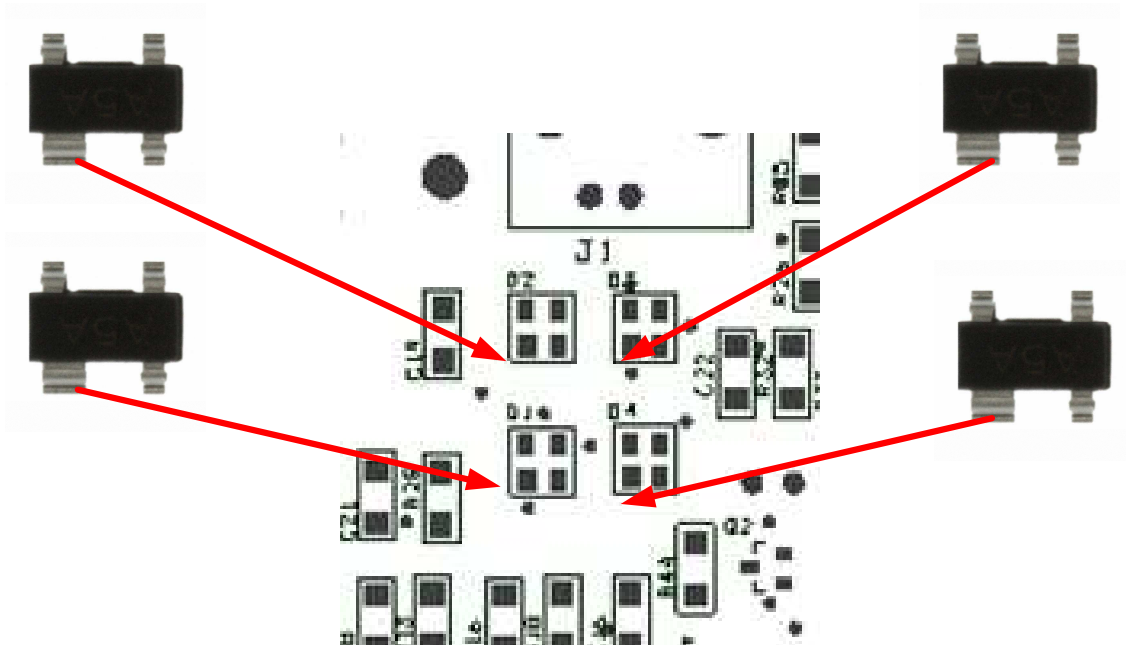

Figure 2, D1..D4 Orientation

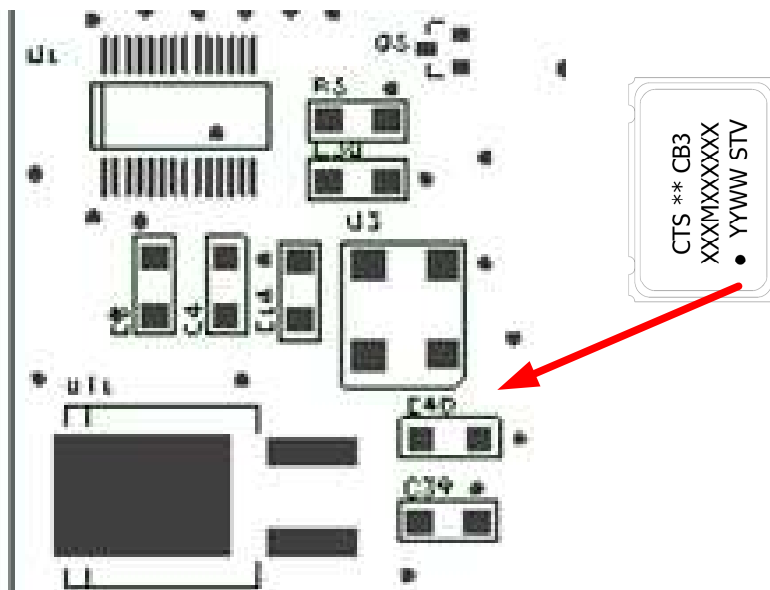

Figure 3, U3 Orientation

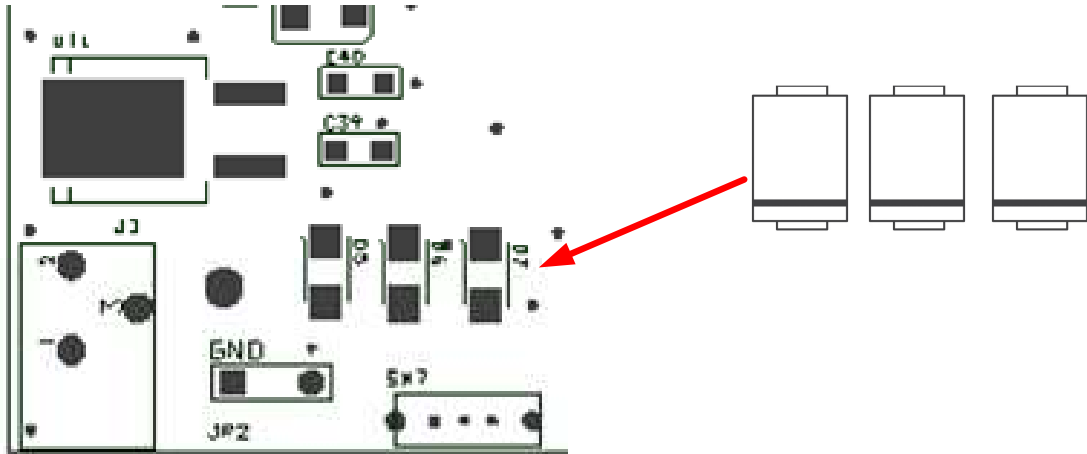

Figure 4, D5, D6, D7 Orientation

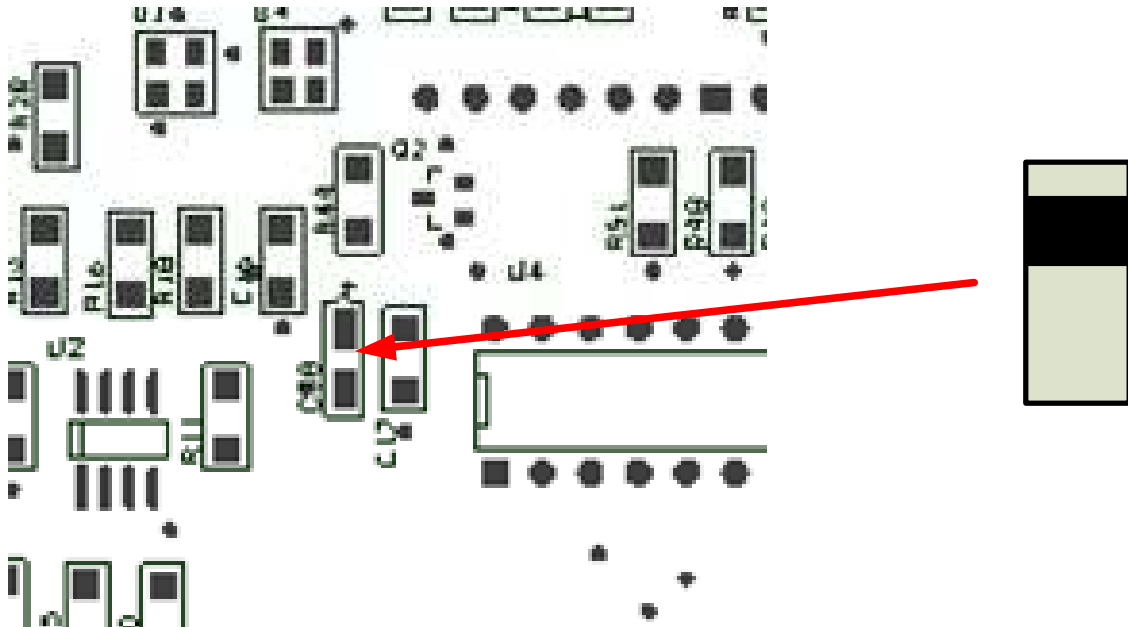

Figure 5, C38 Orientation

The solder technique is similar to the used for the ICs, apply solder flux to the component pads, pre-solder one of the pads on the board where the component will go, hold the component in place with tweezers on the tinned pad, reheat the tinned pad and component to reflow the solder onto the component lead, thus holding the component in place; and lastly solder the other end of the component to its pad.

For efficiency, organize the job by assembling the components groups with the same value at the same time, for instance, starting with the 0.1uF capacitors bag.

7.3 Installing the trough-hole components

The assembly of the trough-hole components is quite easy and components can be assembled in any order, except the display connector JP1 and the pushbuttons SW1 to SW6 which have to be left to the end and mounted in the opposite board side. The components U6, U9, and U10 need a bit of preparation as it will be necessary bending the terminals with the aid of flat pliers. Both U6 and U9 will be mounted lying on the board and need a heatsink that is screwed to the PCB using the drill provided. The screw head should be in the opposite side and the supplied washer prevents the contact of the screw head with the PCB.

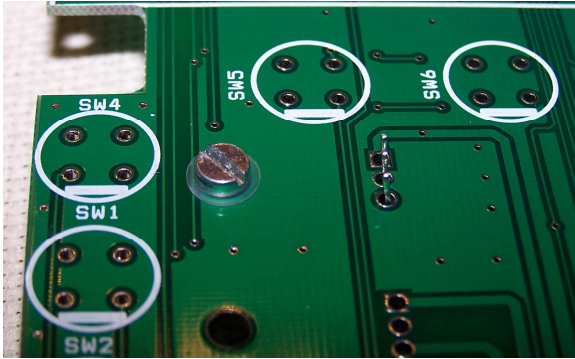

Having completed the assembly of all parts on the components side, then you will proceed by mounting the buttons on the opposite side, taking care to observe proper polarity. The notch marked on the silkscreen of the plate must match the flat side of the button.

The last component to be mounted is the display connector JP1. The connector is a header in which the short terminals side will be soldered on the PCB side. Make sure the connector is perfectly perpendicular to the board. After assembly the header you can mount and solder the display. The display must be perfectly aligned in parallel with the board and be sure that the bezel does not make contact to the PCB. After the soldering operation you shall cut the excess of the terminals in the display side with the help of cutting pliers.

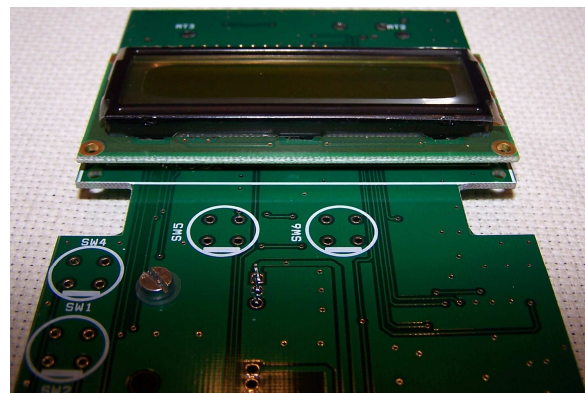
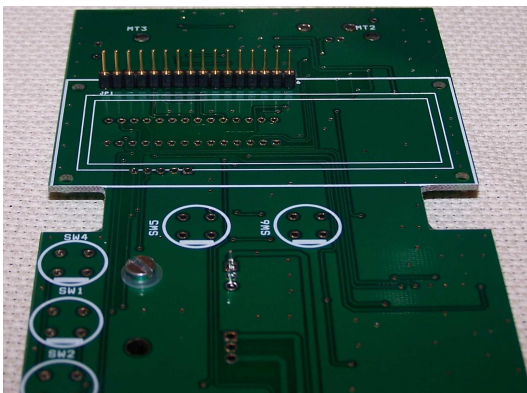

Congratulations, once it gets to this you are finished assembling the board. At this point you can optionally connect the battery holders or wait until later since you can do the power-up by connecting a power source. The battery holders are to be interconnected in series, i.e. the

negative (black) of one of the supports should be soldered to the positive (red) from the other and then secure the connection with a piece of duct tape. Finally the spare positive (red) should be soldered to the board in the position marked as '+' from JP2. The spare terminal negative (black) shall be soldered to the 'GND' of JP2.

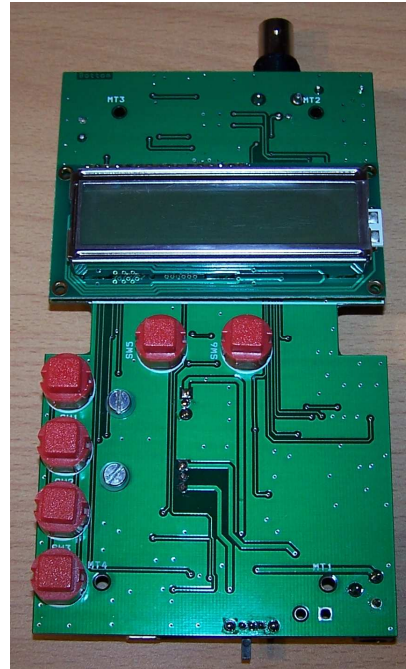
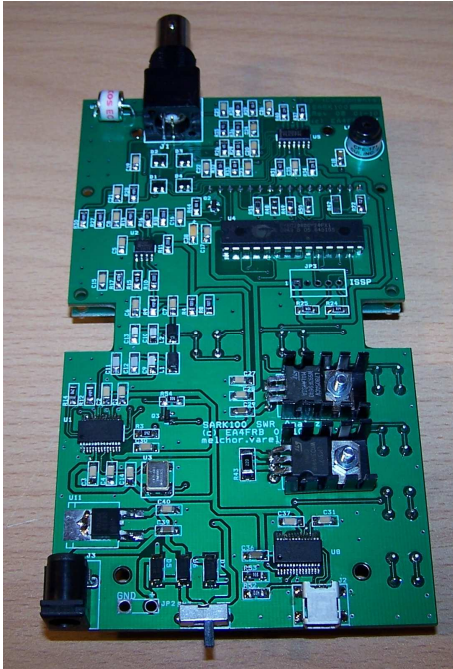

7.4 Power-up and Tests

Prepare for the tests

Once you're ready to connect the power supply to the SARK100, position the board (out of the enclosure) oriented with the display and controls facing up. We recommend using a power supply with current limitation for the first checks. For example, you could limit the current to a maximum of 500mA while and be assured that a short circuit will not blast away circuit traces in the process of first applying power. Another alternative is to use the batteries as they have a limited current capacity.

Apply power and see display on the LCD

After plugging in the power supply and moving the power slide switch, you will see on the LCD a welcome text for about half a second and then a warning text indicating that the instrument is not calibrated for about half a second. This warning is absolutely normal and will always appear at the start-up if the instrument is not calibrated. Then the analyzer will enter in impedance measurement mode, showing the frequency in the first line; and the SWR and the impedance modulus in the second line. If you don't see this on the LCD, proceed to the Troubleshooting section.

Press MODE Pushbutton to select operating modes on the LCD

Successively pressing the MODE button you can select one of the SARK100 operating modes: impedance (magnitude), complex impedance, capacitance, inductance, and off. If you connect a load or an antenna you will see the measurement results in the different ways. Leave impedance mode selected for the following tests.

Press the arrow buttons to change the frequency

Pressing the up or down frequency pushbuttons, the frequency will rise or fall according to the programmed value of frequency step. If left down either button for more than five seconds you will automatically increase the frequency step for a greater search speed. In the case of exceeding the limit of frequency band, the analyzer will switch to the new band where it is displayed on screen for half a second to inform the user of the new band.

Press the button BAND to change the band

Successively pressing the BAND button you can select one of the SARK100 bands. Pressing this button selects the next higher band, except the last one which should start with the lowest. The display shows the new band for about half a second. If this is the first time you access the band it will select the centre frequency. In the event that has already been worked previously in this band will return to the last frequency selected, since it is stored when changing band.

Press the button SCAN to scan the band

When you press the SCAN pushbutton, you initiate an automatic scan of the selected band. The scan starts at the initial frequency of the band and it is progressively increased using the programmed step value and ends at the end of the band. During the scan the analyzer will calculate the SWR that will be shown on screen in addition to frequency, and also store the 2:1 SWR points and minimum SWR value. Notice that when it is detected the 2:1 SWR points the buzzer is sounded to alert the user of the event. When the scan process is finished the analyzer will show the bandwidth and then pressing any key the instrument will impedance mode with the frequency of minimum SWR selected. In the case of not finding a resonance point will show an error message on screen.

Connect an antenna with a resonance frequency of a known value or a dummy antenna to verify the operation of this function. The instrument should detect the resonance point correctly; otherwise proceed to the Troubleshooting section.

Press the CONFIG button to enter the setup menus

The CONFIG button allows access to the configuration menus and extended functions. You can see the available options by pressing the button successively. To select either option press the button VAL and the button CAN to exit.

Select the PC Link function of the setup menu

To check the USB connection to the PC you must first have installed the USB driver (FTDI) and need a USB cable (not included in the kit). Once you've connected the USB cable and power analyzer, you can check in the device manager of the PC which COM port number is assigned

to the analyzer. If your PC has correctly identified the port you can run the HyperTerminal program on the PC and configure the port with settings: 57.600, 8, n, 1, and no hardware flow control. Once done you can start the connection on the PC side and in the analyzer side, select the "PC Link" option in the configuration menu. If all goes well it should appear in the HyperTerminal window a welcome text and a command prompt. At this point you can enter any of the commands described in Appendix H: If it not were possible to establish the USB connection proceed to the Troubleshooting section.

7.5 Preparing the Enclosure

The SARK100 is supplied with a suitable case for the instrument but this comes without the cutouts. For this purpose it is supplied the cut patterns printed on a paper sticker that has to be glued to the box and the panels. In addition you can find the detailed plans in electronic format at the project website. You can use different techniques to make the cutouts, for the presented here you need a hand drill, a thin cutting fretsaw, file, and sandpaper for a proper finish.

You can start the job by the plastic enclosure and then with the aluminium panels. The enclosure consists of two plastic covers, which one of them has two holes for the locking screws. The cutouts will be done in the cover with no holes and that will be the front of the instrument. The first operation will be to paste the provided sticker pattern on the cover. It is very important align correctly the pattern to ensure that the pushbuttons and the display fit perfectly. The tolerances are small so it is important to make sure to avoid problems. The reference points are the four turrets located in the inner side of the cover that need to match with the corresponding marks printed in the pattern. Please check the dimensions with the drawings before starting the cutting job as a final verification.

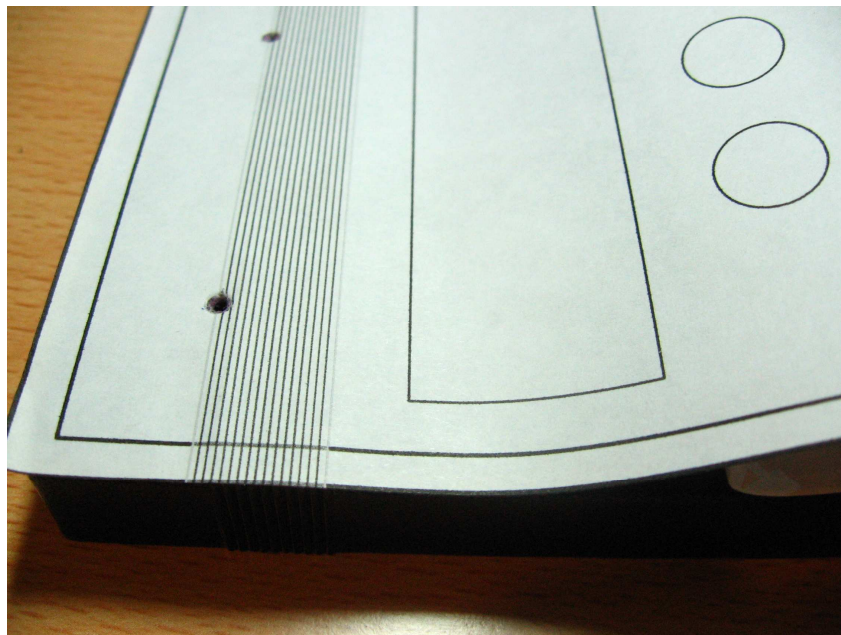

You can start the job by drilling the holes for the pushbuttons using the handdrill and a 13mm spade drill bit. You should mark the center point of each of the drills, for example, by using the hot tip of the solder with the objective of directing the drill bit and holding it in place.

The next step will be the cutout of the display rectangle. You will need drilling a hole to permit the passage of the blade of the fretsaw and then perform the cuts with precision following the pattern.

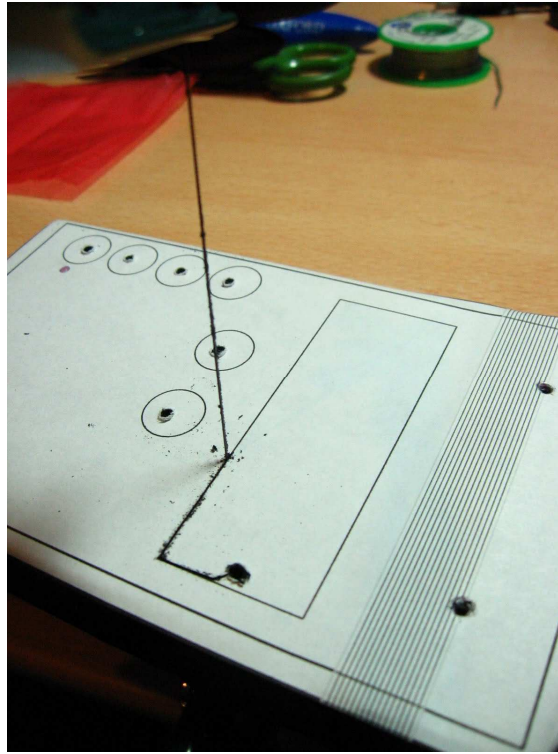

The panels will be prepared in a similar way, first applying the sticker patterns on the two panels and then perform the cutouts. For the the BNC connector hole you will need the handdrill and a 13mm drilling bit for metal. For the other cutouts you will need the handdrill with a small drilling bit to just permit the passage of the blade of the fretsaw and then perform the cut with precision. Once you have finished the drills you can use a file and sandpaper for a smooth finish.

7.6 Installing the PCB in the enclosure

If the previous step was successfully, the board should fit correctly in the cover with the cutouts allowing the positioning of the buttons and display. Once the board is positioned screw the four supplied screws for this purpose.

Then you will need to glue the two battery holders on the inside of the back cover, in the positions shown in the photo on the next page. Finally close the box, screw the two locking screws, and place the supplied rubber feet.

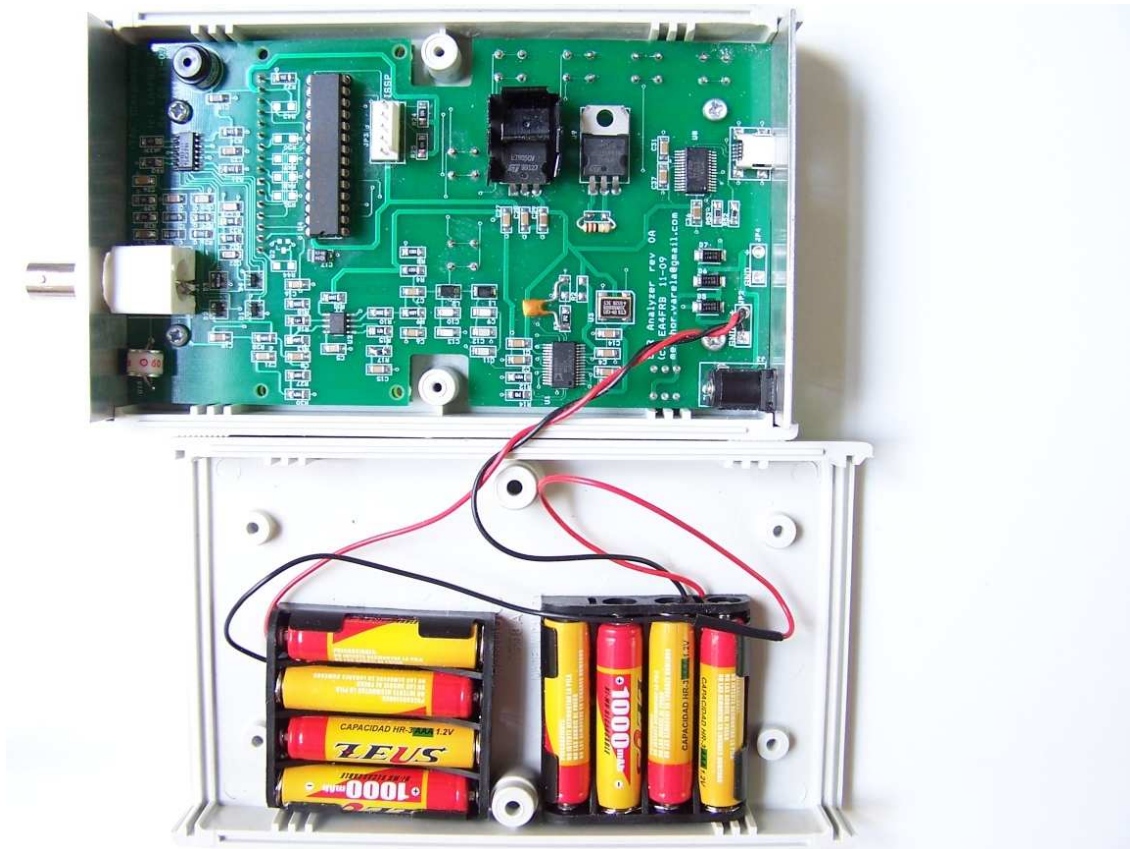

7.7 Manufacturing the Overlays

Now it is time to improve the look of the instrument. This design gives the art design to create overlays for the front cover and optionally for the panels. You can either use this design as is or as a template to customize the design according to your personal taste. There are many techniques available to create the overlays or direct stamping the enclosure. Many of them are expensive when produced for small quantities mainly because the cost of the preparation of the tooling. In this section I'm going to show you a simple and affordable homebrew technique but with a nice result.

The technique basically involves printing the supplied design on photographic paper (A4 size) using a normal inkjet printer and making sure you use photo quality. Photo paper should be sticker type but normal type is fine too but requires then gluing to secure to the enclosure. Once printed the art it is necessary waiting the dry time recommended by the paper manufacturer, usually 24 hours.

After the drying time you will proceed to the coating of the paper to give greater consistency and withstand the conditions of use. You will use a transparent acrylic lacquer in spray form, which is normally used for modelism, decoration, or crafts. You will have to apply several layers following strictly the lacquer manufacturer's instructions. Then you will have to allow the necessary time to dry, normally 24 hours.

After the drying time and with the help of a cutter and a rigid rule, you will have to perform the cutouts with great care and precision. You will start with the display rectangle, the buttons, and the cutouts for the panels. Finally you will proceed with the cutouts of the overlays outline. It is important following this order because it is easier to perform the delicate cuts of the holes with all of the paper support structure.



Finally, carefully paste the overlays to the front enclosure and the panels. The result must be like the following illustrations, with one sample with the box in gray and another in black.



A good recommendation before making the whole process is to do a test print on plain paper, apply the cuts and see how it looks on the box. This will also serve as training and will make you sure that you are using the correct print settings and measures are being properly observed.

8 Connections and Controls

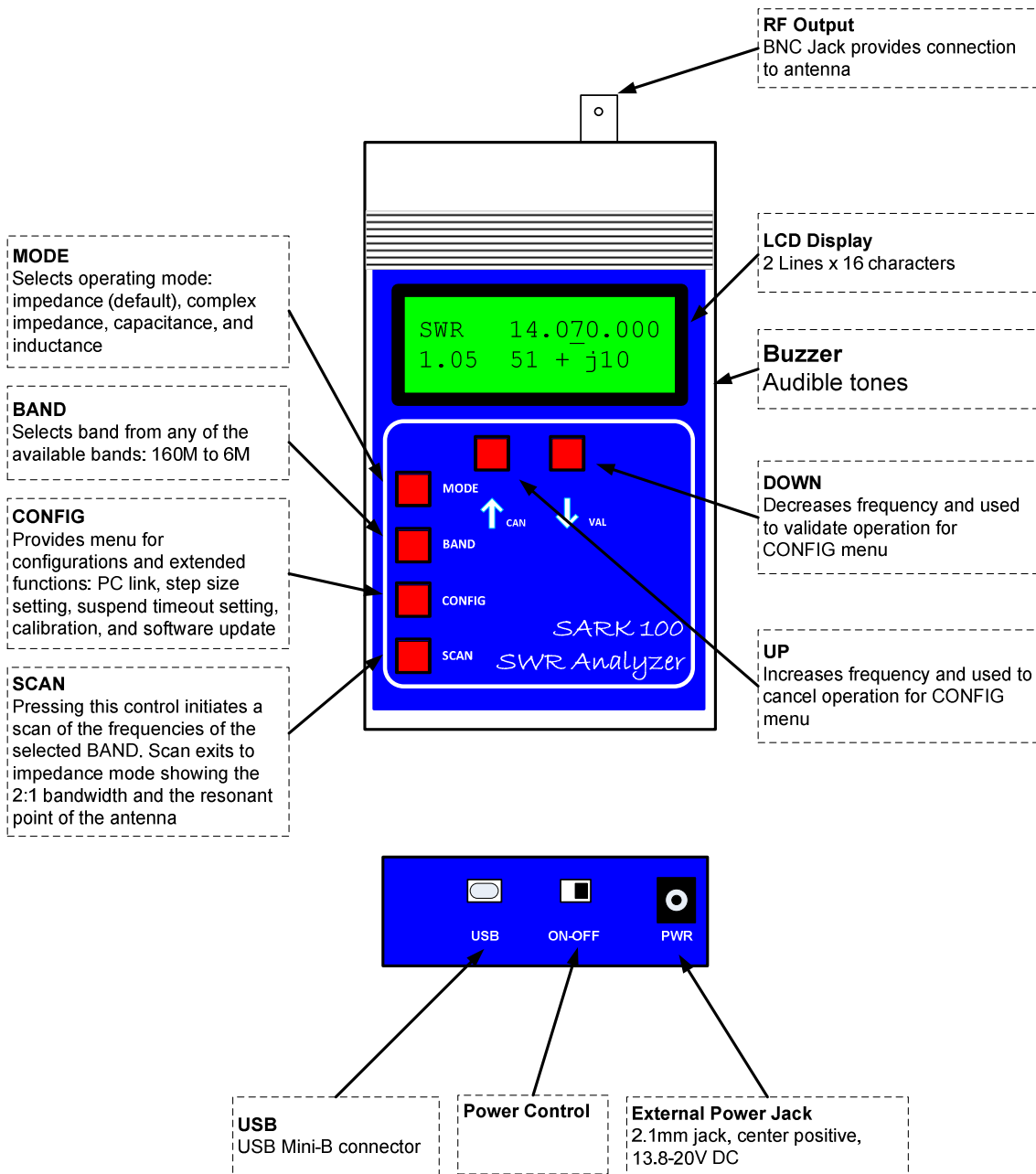

9 Antenna Analyzer Operation

Power-on

Power is turned on to the SARK100 by sliding the switch located on the bottom panel. After power-on the unit will display for half a second the following welcome message:

```
SARK100 Analyzer  
(c) EA4FRB 10 V11
```

V11 indicates the unit firmware version. This information is important to check on the website of the project if there is a newer version. Then the instrument automatically switches to impedance mode that is the default mode and LCD shows frequency, SWR, and the magnitude of the impedance:

```
SWR 14,100.000  
>10 Z=2000
```

The analyzer has an automatic power-save function. This function detects that no button was pressed after a user programmable time and goes into a power saving state and which turns off the display. In this state the press of any button will start immediately the unit returning to the same state before the suspension, i.e. the same function and frequency selected. This function can be disabled by the user.

It is important to note that this is an energy saving feature but not a full power-off, i.e. the instrument continues to have a significant consumption so it is recommended shutting down completely in the case it is not going to be used.

User Interface

The user interface consists of six buttons, four aimed at selecting the functions available and two are used primarily to select the frequency but have the dual function of canceling and validate respectively. All functions are summarized in the Appendix J:

Adjusting the Frequency

Frequency is changed by adjusting a single digit indicated at the point in the display where the cursor '' is by pressing either frequency change button. Upon power-up of the instrument, the 10 kHz digit is the adjustment point, as shown by the digit with the cursor in the display below.

```
SWR 14,100.000  
1.02 Z = 40Ω
```

To move the cursor to a different digit to be adjusted, press simultaneously the frequency change buttons. The cursor will move to any of the seven available digits, allowing subsequent up/down adjustment of that digit after pressing again the frequency change buttons. A blinking cursor will be displayed during the digit adjustment mode.

SWR 14,1■0.000

1.02 Z = 40Ω

Pressing the left button will increase the digit value and, correspondingly, the signal generated by the unit. Pressing the right button will decrease the digit and the generated signal.

When the digit is incremented past 9, or when it is decremented past 0, the digits above the selected adjustment point are rolled up or down, respectively. Using this frequency adjustment scheme, the user can conveniently pick an “increment” digit and manually scan frequencies with the desired granularity. Rough scans can manually be done by positioning the cursor under the 100 kHz digit or the 1 MHz digit, giving a wide and course scan of the frequencies with a quick twist of the dial.

The signal frequency can then be set to the area of interest and the cursor set to a lower granular digit (e.g., 10 kHz or 1 kHz) in order to manually perform a detailed scan while watching displayed results for SWR, impedance and reactance.

MODE

Successively pressing the MODE button you can select one of the SARK100 operating modes: impedance (magnitude), complex impedance, capacitance, inductance, and off.

Impedance Mode (magnitude)

This is the main mode of the instrument and measures the SWR and the magnitude of the impedance. An example screen is the following:

SWR 14,10.000

1.02 Z = 40Ω

- The top line indicates the mode and the frequency
- The first number on the second line is the SWR, in this case 1.02:1
- The second number is the impedance magnitude (modulus), in this case 40 Ω

In this mode the instrument can be used as a VFO as it keeps the signal in the selected frequency continuously.

Complex Impedance Mode

In this mode it is measured the SWR and the complex impedance. An example screen is the following:

IMP 14,10.000

1.02 45 + j 50

- The top line indicates the mode and the frequency
- The first number on the second line is the SWR, in this case 1.02:1

- The middle value is the resistance, i.e. the real part of the impedance, in this case 45 Ω
- Then it is shown the reactance sign, '+' for inductive reactance and '-' for capacitive reactance. If it is not shown, i.e. ' ' it means that it cannot be determined
- Last term is the reactance, in this case it is 50 Ω inductive reactance

This mode can not be used as a VFO because the frequency is continuously dizzling in order to determine the reactance sign.

Capacitance Mode

This mode allows the measurement of the capacitance. An example screen is the following:

CAP 14,10.000

C = 112.4 pF

- The top line indicates the mode and the frequency
- The bottom line indicates the capacitance in pF

Capacity values must be within the measurement range of the instrument. Given that the maximum impedance specification for the analyzer is 2000 Ω, the display will show a numeric value only when the reactance is less than this value. The formula to calculate the capacity is the following:

$$XC = \frac{1}{2 \times \pi \times F \times C}$$

Inductance Mode

This mode allows the measurement of the inductance. An example screen is the following:

IND 14,10.000

L = 7.8 uH

- The top line indicates the mode and the frequency
- The bottom line indicates the inductance in uH

Inductance values must be within the measurement range of the instrument. Given that the maximum impedance specification for the analyzer is 2000 Ω, the display will show a numeric value only when the reactance is less than this value. The formula to calculate the inductance is the following:

$$XL = 2 \times \pi \times F \times L$$

Off Mode

In this mode it is disabled the DDS and the impedance measurements. It is provided a RF level measurement mode where the measured signal level is displayed in the second line of the

display as a bar graph. This will be useful to know if the antenna is receiving a near RF field which can interfere with the measurements.

OFF



BAND

The BAND button allows selecting the working frequency band within the bands available. Pressing this button sequentially selects the next higher band which value is shown in the LCD, and it is changed the frequency. If it is the first time accessing the band, the frequency will be set to the middle value. Otherwise it will be set the previous frequency value, since this is stored when changing the band.

Band	Lower Frequency	Middle Frequency	Upper Frequency
160M	1,000.000	1,800.000	2,000.000
80M	2,000.000	3,700.000	5,000.000
40M	5,000.000	7,100.000	8,000.000
30M	8,000.000	10,100.000	11,000.000
25M	11,000.000	12,000.000	13,000.000
20M	13,000.000	14,100.000	17,000.000
17M	17,000.000	18,100.000	19,000.000
15M	19,000.000	21,000.000	23,000.000
12M	23,000.000	24,900.000	26,000.000
11M	26,000.000	27,000.000	28,000.000
10M	28,000.000	29,000.000	31,000.000
8M	31,000.000	40,000.000	49,000.000
6M	49,000.000	51,000.000	53,000.000

SCAN

Pressing the SCAN pushbutton will automatically sweep the antenna analyzer test signal across the band range previously selected, incrementing from the lower frequency limit to the upper

frequency limit, in steps according the programmed step value. During the scan the SWR is measured and updated on the screen as well as the current frequency value. Each SWR value is compared to previous value in order to determine if a minima, or a “dip”, has occurred at this point in the scan. If so, that data point is stored for later display. Besides the 2:1 points are stored in order to determine the bandwidth. An example screen during the scan is the following (frequency and SWR are updated continuously):

```
SCAN  14,100.200  
1.30
```

Notice that when detected the 2:1 SWR points the buzzer is sounded to alert the user of the event. After the scan process the instrument will show the bandwidth and after pressing any key the instrument will switch to impedance mode with the frequency set to the frequency value corresponding to the minimum SWR point.

```
BW      35.000  
Press any key
```

In the case of not finding a resonance point the unit will display the following error message on the screen.

```
Err No Matching  
Press any key
```

CONFIG

Successively pressing the CONFIG button you can select one of the SARK100 configuration modes and extended functions. To select either option you need to press the button VAL and for exit you need pressing the button CAN.

PC Link

The PC Link function lets you control the SARK100 from your PC using the USB connection. The PC USB driver provides an emulation of a COM port and the SARK100 provides a command interface so you can be control the instrument from a terminal program such as HyperTerminal or any other program designed for this purpose, e.g. PCC-SARK100.

To use this feature you must have installed the USB driver, see Appendix E: and connect the USB cable. The COM port setting is 57600, 8, n, 1, with no hardware flow control. By entering this function the analyzer will send the following text to the terminal and will display the command prompt:

```
SARK SWR Analyzer V05  
>>
```

The available commands are described in Appendix H: These can be typed from the HyperTerminal window and the results will be returned to the terminal. The SARK100 will show the last processed command in the bottom line of the LCD.

Step Size

This function allows you to change the value of the frequency step for the SCAN and for the increase/decrease frequency buttons for the impedance measurement modes. Successively pressing the CONFIG button you can select one of the step values. To select either value you need to press the button VAL and for exit you need pressing the button CAN.

The following values are available: 10Hz, 100Hz, 1kHz, 10kHz, and 100kHz.

Suspend Timeout

This feature allows you to program the user idle time for the automatic power-save feature. Successively pressing the CONFIG button you can select one of the idle time values. To select either value you need to press the button VAL and for exit you need pressing the button CAN.

The following values are available: Off (disabled), 30 seconds, 60 seconds, and 90 seconds.

Calibrate

This function allows calibrating the instrument in order to get better accuracy. By entering this function the user is instructed to follow a series of steps which are described in detail in the Appendix G:

Software Load

This feature allows the software update of the instrument using the USB interface. The update procedure is described in detail in the Appendix F:

10 Uses for an Antenna Analyzer

The SARK100 antenna analyzer is a useful tool for the amateur radio station or the homebrewer's workbench. This section will describe the basic uses, as well some advanced techniques for which you can use the analyzer to get intermediate measurements in order to compute the desired result.

10.1 Antenna Measurements

The antenna is simply connected to the analyzer RF output and the analyzer is set to the desired frequency. The instrument measures the SWR, impedance, resistance, and reactance. The SCAN function will be helpful to automatically find the resonance frequency and the bandwidth of the antenna.

10.2 Measure Feed Point Impedance

Connecting the analyzer directly at the antenna terminals or remotely through a halfwavelength of transmission line allows direct measurement of the antenna terminal impedance. This is often useful with vertical antennas.

A matching network can be connected to the antenna and then adjusted for best SWR on the analyzer.

10.3 Measure Ground Losses

With short vertical antennas, measuring the impedance directly at the feedpoint allows estimation of ground loss or loading coil loss. For example a $\frac{1}{4}$ wave vertical will have a resistance of about 36 ohms at resonance. Any higher reading indicates ground loss.

Similarly shorter antennas (when resonated) will have lower resistance values. Reading a good SWR may mean excess loss and measuring the actual impedance allows gauging just how much loss.

10.4 Adjust Antenna Tuners

The analyzer can be used to adjust an antenna tuner for a perfect match without the need to transmit a strong signal from the station rig. The analyzer uses only milliwatts of power lessening the possibility of causing interference, see Figure 8.

10.5 Capacitor Measurement

There are several ways to measure capacitance with the SARK100. The simplest is to connect the capacitor across the RF output connector and select Capacitance from the Mode pushbutton menu. You can accurately measure capacitance values as long as the reactance at the measurement frequency is within the impedance measurement specifications of the analyzer (about 10 to 2000 Ω).

Another way to measure capacitance with the SARK100 is to measure it in a series resonant circuit. (See Figure 6 and Figure 10). You will need an inductor of known value and a 51 Ω carbon composition or film resistor. It is recommended that a small 5% tolerance choke with an inductance of between 1 and 10 μH be used. Common RF chokes are fine and can be obtained from most full-service mail order component suppliers.

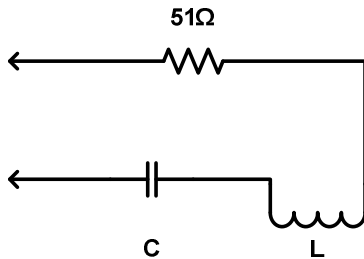

Figure 6

To measure capacitance by the second method, connect the components as shown in Figure 6. Then adjust the operating frequency for lowest SWR and record the frequency. Now you can calculate the capacitance using the formula:

$$C = \frac{25530}{F \times F \times L}$$

Where C is the capacitance in picofarads, F is the frequency in MHz and L is the inductance in microhenries.

10.6 Inductor Measurement

There are several ways to measure inductance with the SARK100. The simplest way is to connect the inductor across the RF output connector and select Inductance from the Mode pushbutton menu. You can accurately measure inductor values as long as the reactance at the measurement frequency is within the impedance measurement specifications of the analyzer (about 10 to 2000 Ω).

Another way to measure inductance with the SARK100 is to measure it in a series resonant circuit. (See Figure 6 and Figure 10). You will need a capacitor of known value and a 51 Ω carbon composition or film resistor. The capacitor should have a tolerance no wider than 10% and have a low loss dielectric composition such as NP0 ceramic or mica. A capacitance value of about 100 pf is appropriate for many RF measurements.

You can make your own precision capacitor from a piece of coaxial cable. Common RG-58 type 50 ohm coax has a capacitance of about 29 to 30 pf. For example RG58/U is specified at 28.8 pf per foot so a length of about 3.5 ft – including a 1" pigtail for attachment will serve as a fairly accurate 100 pf capacitor.

To measure inductance by the second method, connect the components as shown in as Figure 6. Adjust the operating frequency for lowest SWR and record the frequency. Now you can calculate the capacitance using the formula:

$$L = \frac{25530}{F \times F \times C}$$

Where L is the inductance in microhenries, F is the frequency in MHz and C is the capacitance in picofarads.

10.7 Measure Inductor Q

The Q of an RF inductor can be measured with a very simple setup. First measure the inductive reactance X_L of the inductor and record this value. Now connect it to the Analyzer as shown below in Figure 7.

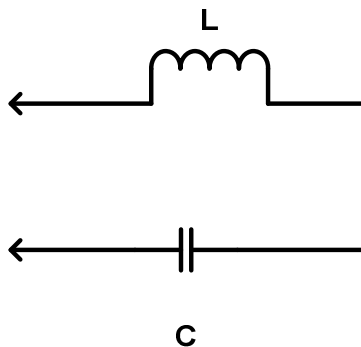

Figure 7

Capacitor C must be chosen to resonate with L at the frequency where you want to measure the inductor's Q. The Inductor and Capacitor Measurement section of this manual shows how this capacitor value can be determined. Now tune the Analyzer for the lowest R (resistance) value with a reading of zero X (reactance). If R is above 10 ohms you can now calculate inductor Q using the formula:

$$Q = \frac{X_L}{R}$$

If R is less than 10 Ω a slightly different method needs to be used. In this case use the test setup shown in Figure 6. Adding the noninductive (carbon composition or film) $\frac{1}{4}$ or $\frac{1}{2}$ watt 51 Ω resistor allows more accurate measurement of the series resistance of the inductor.

Again tune the analyzer for lowest R (resistance) value with a reading of zero X (reactance). Record this resistance value. Now connect the 51 Ω resistor directly across the analyzer's RF output connector and measure its exact value at the resonance frequency and record it. Next subtract the exact 51 Ω resistor value from the measured R value and use this new resistance in the above formula to calculate the Q value.

10.8 Transmission line characteristic impedance

The characteristic impedance of coaxial, twisted pair, open wire or ribbon type feedlines can be estimated using the SARK100. Practical measurements are best done in the mid-tuning range of the instrument where accuracy is optimum and feedline lengths are reasonable; so this procedure will be performed between 7 and 21 MHz.

The measurements need to be done with a transmission line over frequencies where the feedline is at about 1/8 wavelength at the low frequency end and something over ¼ wavelength at the high frequency end, so it is recommended that a length of about 4.9m (16 feet) is used.

Connect the near end of the feedline to the SARK100. Connect a 1000 Ω carbon or Cermet potentiometer to the far end with leads no longer than 2.5 cm (one inch) or so. Initially set the pot to its highest value, see Figure 11.

Ensure that the transmission line is supported for its entire length in a fairly straight line and kept several inches from any conductive surface or material. This is important to minimize any detuning effects. Ideally the line should be dressed along to top of a wooden fence or supported by fiber rope or string.

Now tune the SARK100 over the range of 7-to-21 MHz while noting the resistive (R) and reactive (X) values. More than likely they will vary widely over the tuning range. Now readjust the potentiometer to a slightly lower value and do another sweep while observing the variation of R and X values. At some potentiometer setting the R value will vary very little over the tuning range while the X value will remain near zero. This is the estimated characteristic resistance.

10.9 Transmission line losses

Transmission line loss for 50-ohm feedlines can be easily measured using the analyzer. The basic operating principle is that loss in transmission lines attenuates RF sent through them. When the line is connected to the analyzer and the far end is short or open-circuited there is a theoretically infinite SWR. If the feedline had zero loss this would be the case. However since any real line has some loss both the forward and reflected power are attenuated and a finite SWR is measured.

For most good quality new coaxial feedlines the loss at HF frequencies will not exceed several dB per 30 meters (hundred feet); however as they age the dielectric becomes lossy so it is a good idea to periodically check the loss. Measurement is simple. All you have to do is to remove the load, short-circuit the far end of the feedline, and then connect the near end to the analyzer's RF output connector. Measure the SWR and refer to table below for the approximate corresponding loss. If the measured SWR is above 9:1 that's good news since the SWR then is less than 1 dB. If you vary the analyzer frequency you will see that SWR decreases with frequency indicating that loss increases at higher frequencies.

Approx Loss	Measured SWR
1 dB	9:1
2 dB	4.5:1
3 dB	3:1
4 dB	2.3:1
5 dB	2:1
6 dB	1.7:1
7 dB	1.6:1
8 dB	1.5:1
9 dB	1.4:1
10 dB	1.3:1

10.10 Transmission line stub lengths

Measurement of quarter and half wave transmission line stubs can be performed regardless of the transmission line characteristic impedance. The method relies on the fact that an open-circuited quarter wavelength line or a short-circuited line acts like a precise short circuit at the chosen frequency of operation.

With either type of feedline first cut it about 10% longer than the desired length, taking the appropriate velocity factor into account. The velocity factor of common feedlines is available from manufacturer's literature or references such as the ARRL Antenna Book. If you cannot find the value or if you are using a custom type of feedline, the "Velocity Factor Measurement" section in this manual provides a way to determine this value. The following formulas can be used to estimate the length of transmission line required.

For a half-wavelength stub the length is:

$$L = \frac{150000 \times VF}{F}$$

Where L is the length in cm, VF is the velocity factor and F is the operating frequency in MHz for the stub.

Similarly for a quarter-wave stub use the formula:

$$L = \frac{7500 \times VF}{F}$$

To determine the length of a half wave stub, connect the near end of the transmission line through a 51 Ω resistor as shown in Figure 9 to the analyzer's RF output connector. Short circuit the two leads at the far end of the half wave stub.

Ensure that the transmission line is supported for its entire length in a fairly straight line and kept several inches from any conductive surface or material. This is important to minimize any detuning effects. Ideally the line should be dressed along to top of a wooden fence or supported by fiber rope or string.

Now tune the SARK100 for minimum SWR and note the frequency. This is the frequency where the transmission line is exactly a half wavelength long. If the initial length was chosen properly it should be below the desired frequency. If so, cut off a short length making sure the far end is still short-circuited, and repeat until resonance is achieved at the desired frequency.

For a quarter wave stub, the above procedure can be used except, of course that the length is different and that the far end needs to be open-circuited.

10.11 Transmission line velocity factor

Velocity factor of a transmission line can be measured using techniques similar to the ones used for measuring quarter and half wave stubs. The procedure can be performed at any frequency that the SARK100 tunes but it is most practical in the vicinity of 10 MHz where line lengths are reasonable and instrument accuracy is optimum.

Either a quarter wave or half wave length can be used; but using the shorter length consumes less feedline if it will be discarded after the measurement. Begin by cutting a quarter wavelength of feedline using the formula:

$$L = \frac{7500 \times VF}{F}$$

For a frequency of 10 MHz and assuming a VF (Velocity Factor) of 1.

Now connect the near end of the feedline to a 51 Ω resistor as shown in Figure 12 then to the analyzer's RF output connector. The far end must be open circuited. Ensure that the transmission line is supported for its entire length in a fairly straight line and kept several inches from any conductive surface or material. This is important to minimize any detuning effects. Ideally the line should be dressed along to top of a wooden fence or supported by fiber rope or string.

Now tune the SARK100 for lowest SWR and note the frequency. VF can now be calculated using the formula:

$$VF = \frac{10}{F}$$

Where F is the measured frequency in MHz.

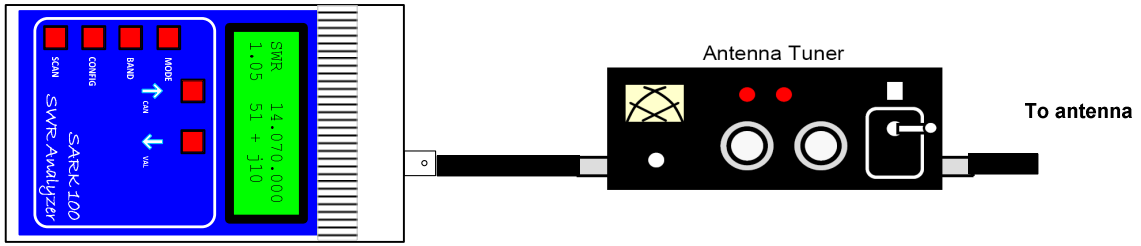

Use the SWR mode to dial in the desired operating frequency. Then adjust the tuner, disconnect the SARK100, connect the Xcvt, and operate!

Figure 8, Adjust antenna tuners

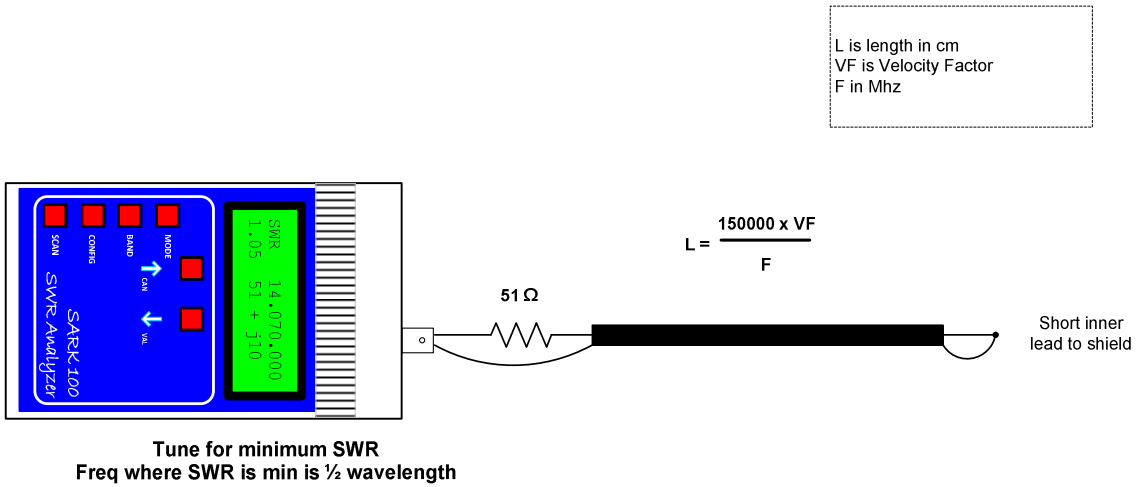

Figure 9, Determining length of a halfwave stub

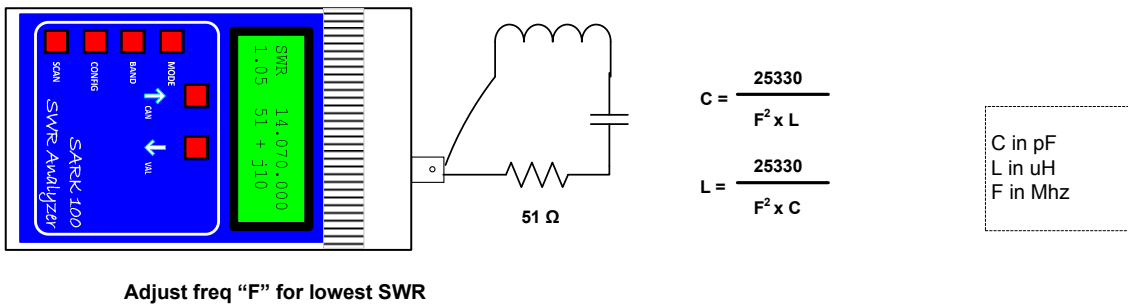

Figure 10, Capacitor or inductor measurement

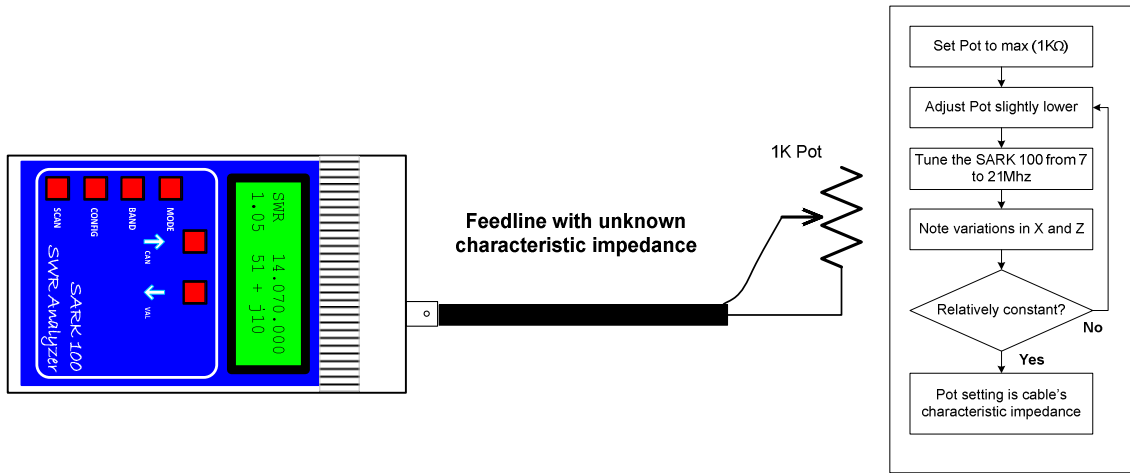

Figure 11, Determining feedline characteristic impedance

Sweep SARK100 to find minimum SWR at some frequency "F"

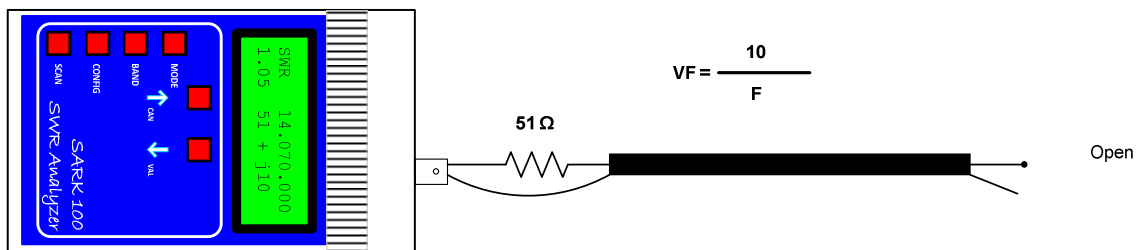

Figure 12, Determining feedline velocity factor

11 PC Software

The SARK100 is controllable from the PC and allows the collection of measurements to be processed by an analysis program. In the project website you can find a simple command line program, PCC-SARK100, which performs control and data capture from the SARK100 and generates a data file compatible with Excel macro ZPlots from Dan Maguire AC6LA. This macro performs the analysis of the measures and displays them in different graphs.

PCC-SARK100

The PCC-SARK100 is a simple command line program which scans in the selected frequency range and stores the measurement results in a file format supported by ZPlots.

Usage:

- PCC-SARK100 -c<com port> -s<start freq> -e<end freq> -t<step value> -o<output file>

Where:

- -c<com port name> COM port name
- -s<start freq> Start frequency in Hertz
- -e<end freq> End frequency in Hertz
- -t<step> Step value in Hertz
- -o<output file> Output file name (without path)

Example:

- PCC-SARK100 -cCOM5 -s14000000 -e16000000 -t10000 -oDipole20m.csv

ZPlots

ZPlots is an Excel macro developed by Dan Maguire AC6LA, which provides the data analysis and display graphs of the impedance data captured by the SARK100 antenna. Usage is very simple, you select the file captured by PCC-SARK100 and automatically displays a representation of the actions of the antenna to the SWR, resistance, reactance, etc.. It also represents Smith chart format. In the following pages there are examples of ZPlots graphs.

The complete manual of the original program is available on the project website.

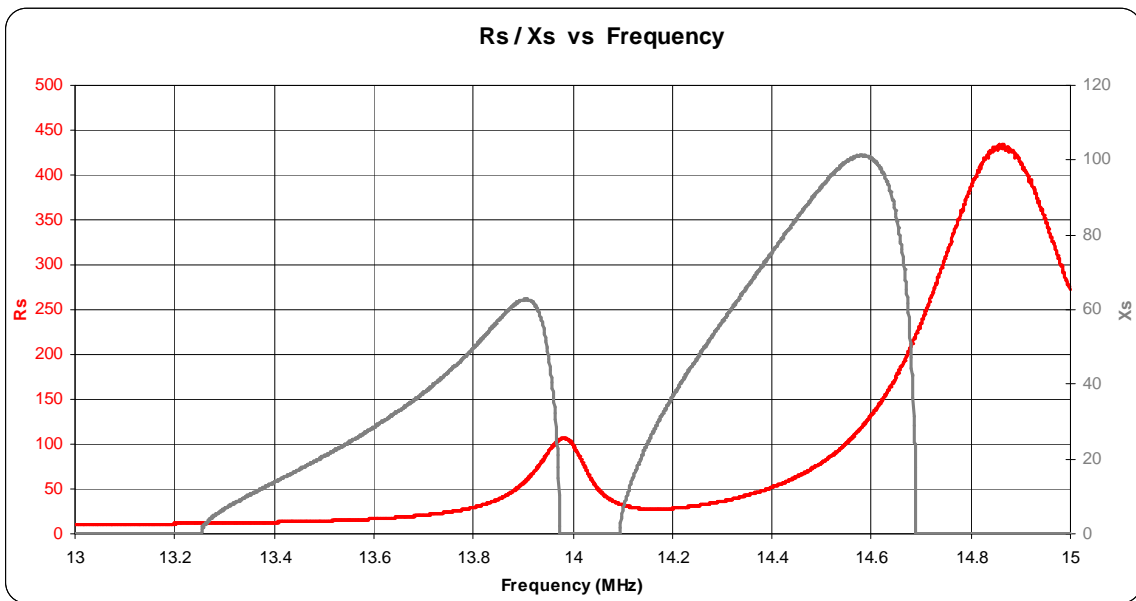
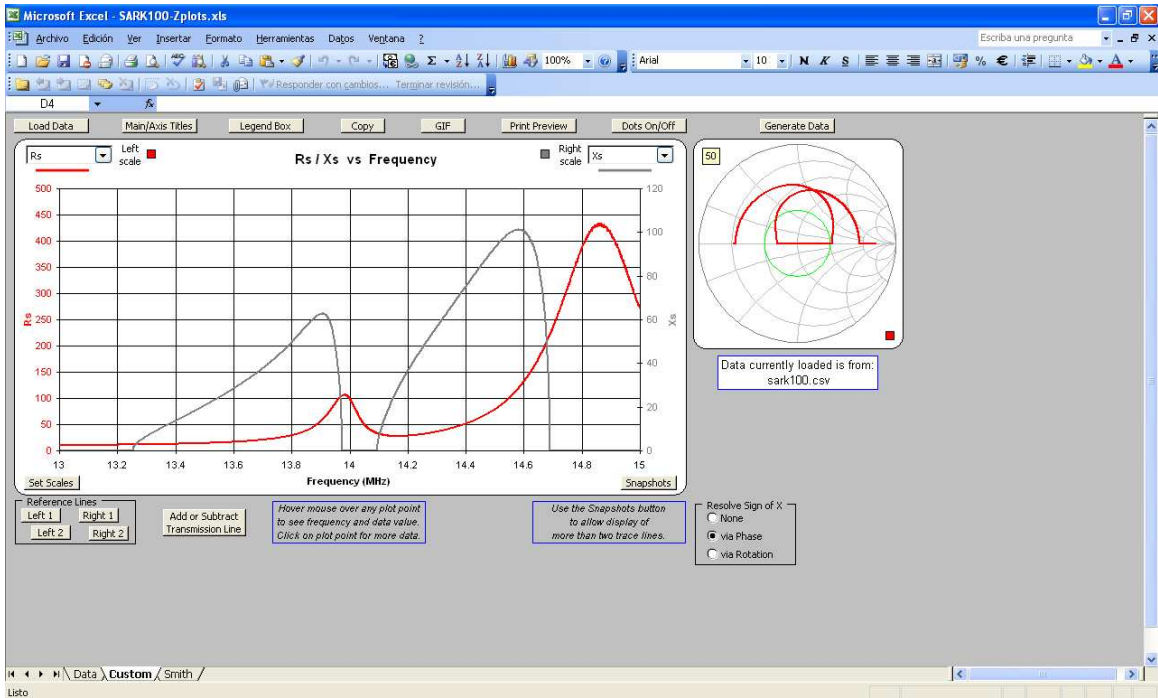

12 PSoC Development

One of the advantages of SARK100 analyzer is that the software is fully upgradeable via USB, the code is open and programmed in language 'C', and also the programming tool "PSoC Designer" is free so you can fully customize the operation of the instrument. Note that the software is available for download on SourceForge and you can participate as a developer in the project and contribute to improving the product.

Depending on your skills, you can customize the messages from the screen (e.g. program your calling in the welcome screen), add new features or modify existing ones, always bearing in mind the limitations of the device. More advanced users could add / improve SARK100 functions using the Chip Editor of the PSoC tool.

It is not my intention to describe the functions of the PSoC and PSoC Designer tool, as there are many tutorials, documentation, and application notes on the website of Cypress Semiconductor. I will give you information on the basics.

The basic installation consists of the following steps:

1. First download and install the PSoC Designer, available at the following link:
<http://www.cypress.com/?rID=34517>
2. Download the source analyzer, available at the following link:
<http://sark100swranaly.sourceforge.net>
3. The source code is zipped, unzip it into a working directory on your PC
4. Make sure you have prepared the necessary environment to perform software updates, as described in Appendix F:

At this point you can launch the PSoC Designer. From the "File" menu you can open the project using the "Open Project / Workspace". Select the directory where the project is and open the project file "SARK100_SwrAnalyzer_BL.app. You can also launch the PSoC Designer and open while the project by double clicking the file "SARK100_SwrAnalyzer_BL.app" in the Windows file manager. Once the project will open up a window such as that shown in the Figure 9.

As a basic tutorial we will modify the software analyzer to show your callsign in the initial screen of the analyzer. Based on the previous screen, these are the steps to perform:

1. In the window "Workspace Explorer" (top right), displays the tab "Source Files" from the "SARK100_SwrAnalyzer_BL" folder. You should see all the source files belonging to the project.
2. Double click on the "msg_eng.c" file which is the module containing all display texts of the analyzer
3. Look for the gWelcome2Str declaration:

```
BYTE const gWelcome2Str [ ] = "(c)EA4FRB 10 " VERSION_STR;
```

4. Modify the text with your callsign and click the save button, for example::

```
BYTE const gWelcome2Str [] = "(c)XYabc 10 " VERSION_STR;
```

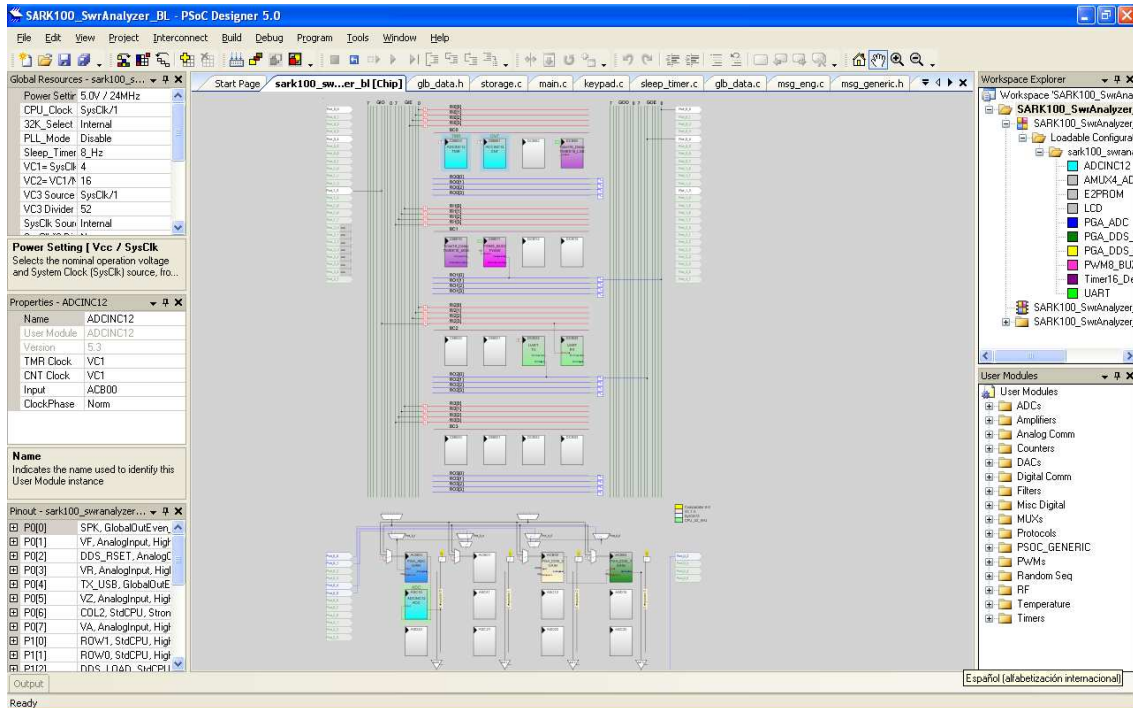

Figure 13, PSoC Designer

5. In the "Build" menu, select the option Build 'SARK100_SwrAnalyzer_BL' Project. You can also invoke this function by pressing F7.
6. If all went well in the window "Output" will indicate that the project has been compiled without errors
7. The downloadable file will be available in the project directory .\SARK100_SwrAnalyzer_BL and has the following name and extension: "SARK100_SwrAnalyzer_BL.hex"
8. Use the procedure for updating firmware described in the Appendix F:
9. Verify that the analyzer now displays your callsign in the welcome screen, if so, congratulations! You have understood the basic steps and you're ready to embark on more advanced mods

13 Troubleshooting

This section is a guide to the event that the instrument does not work as expected after the assembly. You will need some basic tools and the schematics and layout of the board available in the appendices of this manual. In any case, first of all I recommend that you inspect the assembly and soldering carefully. The board is relatively simple so it is easy to review thoroughly to discover any bad soldering or short circuit.

Equipment Needed

If you have an oscilloscope you will have the ability to measure all signals of the analyzer and it will be of great help in case of problems. But if you don't have, the minimum required is a multimeter with the ability to measure DC voltages and resistances. It will be useful to build a RF probe, in case you do not have it, with very easy to find materials as you can see in the following illustration:

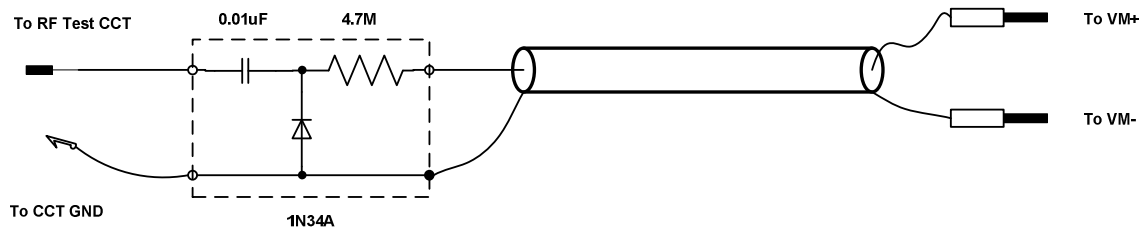

Classic RF Probe

Reads RMS equivalent voltage in test circuit if voltmeter input impedance is 10-11MΩ
 Reads 4X RMS equivalent voltage if voltmeter input impedance is 1MΩ
 (Set VM to measure DCV)

Basic Tests

We'll assume you haven't seen any smoke coming from the circuit board or components. That's always a good starting point for a successful repair of a unit. Otherwise, you'll obviously need to look in the area when the smoke came from, or where the board and components look charred – for that is the place where a component was mis-installed or the place where the problem surfaced from something else.

Power Supply

In the case of powering the SARK100 unit with batteries, make sure you have a voltage of 8.5 V. If the voltage is lower than the RF signal will not be generated properly, and incorrect readings may be shown on the screen. In the case of using an external power supply make sure it is in the range of 13.8 to 20V.

Make sure that the battery polarity is correct and that the external power connector is positive in the center. If any of these connections is reversed, it could damage any of the regulators of entry (U9 and U11) but not the rest of the unit since there are diodes that serve as protection for these events.

Using the multimeter and making sure that the switch SW7 is in the OFF position, check the voltage on the cathode of D5 or D6. If there is not any voltage, the problem might be an incorrect position of D5 or D6, or a failure of U11 though the latter would be quite unlikely.

If that's OK, put the switch SW7 in the ON position and measure with the multimeter U6 the regulator output, i.e. the pin 2. In the event that the measure is not 5V, most likely a short circuit at the board and also notice that the regulator gets very hot. You'll have to turn off the power and seek the cause of the problem, most likely a short tin in any component or connector with the terminals close together.

13.1 Specific problems

Problem	Solution
The LCD shows the following text after the startup. "Uncalibrated" "Press any key"	This is a warning message indicating that the instrument is not calibrated. It is completely normal and even the instrument will function normally but with a small loss of accuracy. This message will disappear once the calibration. Note that the calibration will be lost after a software update which will require recalibration.
The LCD shows the following text after the startup. "Error Vf Level" "Press any key"	In the power-up, the instrument checks the level of the branch of the reflectometer VF. This error will occur if the level detected that does not exceed the required threshold for operation. First turn-off and then on the instrument and if you continue having problems these are the possible causes: <ul style="list-style-type: none"> ➤ RF is not generated, probably because a DDS or a power amplifier fault ➤ The reflectometer can not detect the RF signal, probably by a reflectometer or buffer failure <p>To find the problem you will need an oscilloscope or RF probe and a multimeter. You start following the path of the RF signal, starting with L1 (it is hard to probe in the DDS output), following by the two output stages of U2 (pins 1 and 7), C8 output and RF output connector. If all goes well, measures the VF signal, pin 14 of U5. The level in this signal should be greater than 1.5 V.</p>
The SARK100 turns off automatically after 90 seconds	It is completely normal since the instrument is automatically put in a low-power mode for extended battery autonomy. This feature can be disabled in the CONFIG menu
The instrument shows inconsistent measurements	In case of powering from batteries and if they are discharged the instrument could malfunction and it could even reset. Another possible cause is a failure in either branch of the reflectometer including a failure in any of the detector diodes. Using the oscilloscope or a multimeter, measure the values in the four branches of the bridge and compared with tables next section.
The PC does not recognize the USB device when connected to the SARK100	First make sure you have installed the USB driver supplied. In the control panel of your PC access to the Device Manager and check the status of the device. If all goes well the PC should recognize the device as a COM port with the FTDI driver. Notice that the SARK100 is not USB bus powered, so you need external power or batteries even when connected to USB.

Problem	Solution
	If the PC does not detect the device it may be an assembly error of the USB chip (U8). Check the solders because it is a fine pitch component and could have been a bad soldier terminal or shorted.
The display shows no message	<p>First check that all board supplies are correct including the display supply.</p> <p>One possible cause is that the PSoC microcontroller is not programmed correctly or lost the programming, for example, after an interrupted software update. In this case you should try the software update, see Appendix F:</p> <p>If this is not possible it would be needed reprogramming the PSoC using the provided ISP connection in the board. You will need a PSoC programmer for that purpose. If you don't have it you can ask me for a preprogrammed PSoC.</p>

13.2 Voltage Charts

	VA U4 Pin 1	VZ U4 Pin 2	VR U4 Pin 3	VF U4 Pin 4
Open circuit	0	1,8	0,8	1,8
50 Ω Load	0,7	0,7	0	1,4
Short-circuit	1,2	0	0,6	1,2

14 Theory of Operation – Hardware

Referring to the schematics (Appendix A:), a block by block description is presented in this section.

DDS Signal Generation

The sinusoidal signal generation is done by means of the integrated circuit AD9851 from Analog Devices that includes the DDS synthesis and a 10-bit digital-analog converter. The reference clock is supplied externally by a 30 Mhz oscillator which is multiplied by six internally by the DDS for a 180 Mhz working frequency. This allows a resolution of about 0.04 Hz as the tuning record is 32-bits and a maximum usable frequency of 60 MHz.

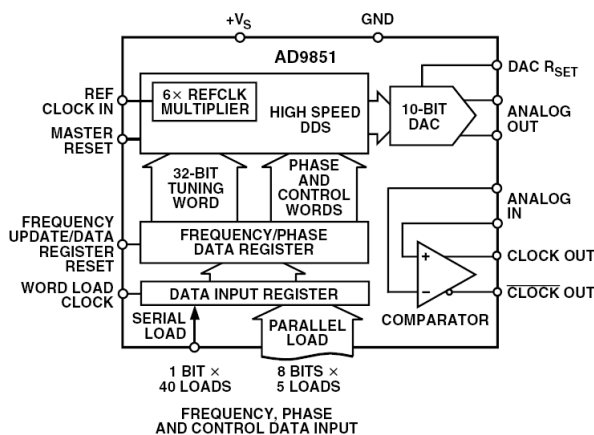

Figure 14, AD9851

The DDS is programmed from the microcontroller using a serial control through signals DDS_DATA, DDS_LOAD and DDS_CLK. The control is done by loading a 40-bit control register which controls the phase, the selection of the multiplier, the control of low-power mode, and the 32-bit frequency control register.

The resetting of the DDS is controlled by the microcontroller through signal XO_EN. This signal in addition to the reset function allows you to disable the oscillator, and control the backlight of the display. In low power mode this signal switches to low level so that the DDS will be in a state of reset, the oscillator disabled, and the display off, hence it will reduce the consumption significantly. This signal is shared for all these functions due to the limited number of ports of the micro-controller.

The output current (amplitude) of the DDS is controlled by the RSET pin. This is fixed by the formula:

$$I_{OUT} = \frac{39.93}{RSET}$$

This is connected to an analog output of the PSoC microcontroller so that you can perform DDS amplitude under software control. This is used in this project to compensate for amplitude roll-off with frequency DDS. Also thanks to the programmable features of the PSoC it would be possible implementing amplitude modulation with low-frequency signals but this quality will not be used for this project.

The DDS output is connected to a fifth-order elliptic filter to reduce unwanted high frequency components and therefore improve signal purity. Since the signal generated by the DDS has small amplitude, it is amplified using a high speed amplifier, AD8008, to a level of about 2 Volts peak to peak. This amplified signal is delivered to the reflectometer and the antenna system.

PSoC Microcontroller

The PSoC microcontroller forms the SARK100 analyzer control core. The PSoC is a true system on a programmable chip that integrates digital and analog functions, memory, and the controller on the chip. It is therefore a very flexible and also has a free development environment, PSoC Designer, which greatly facilitates development. The PSoC used in this project belongs to the family PSoC1, i.e. using the M8C CPU.

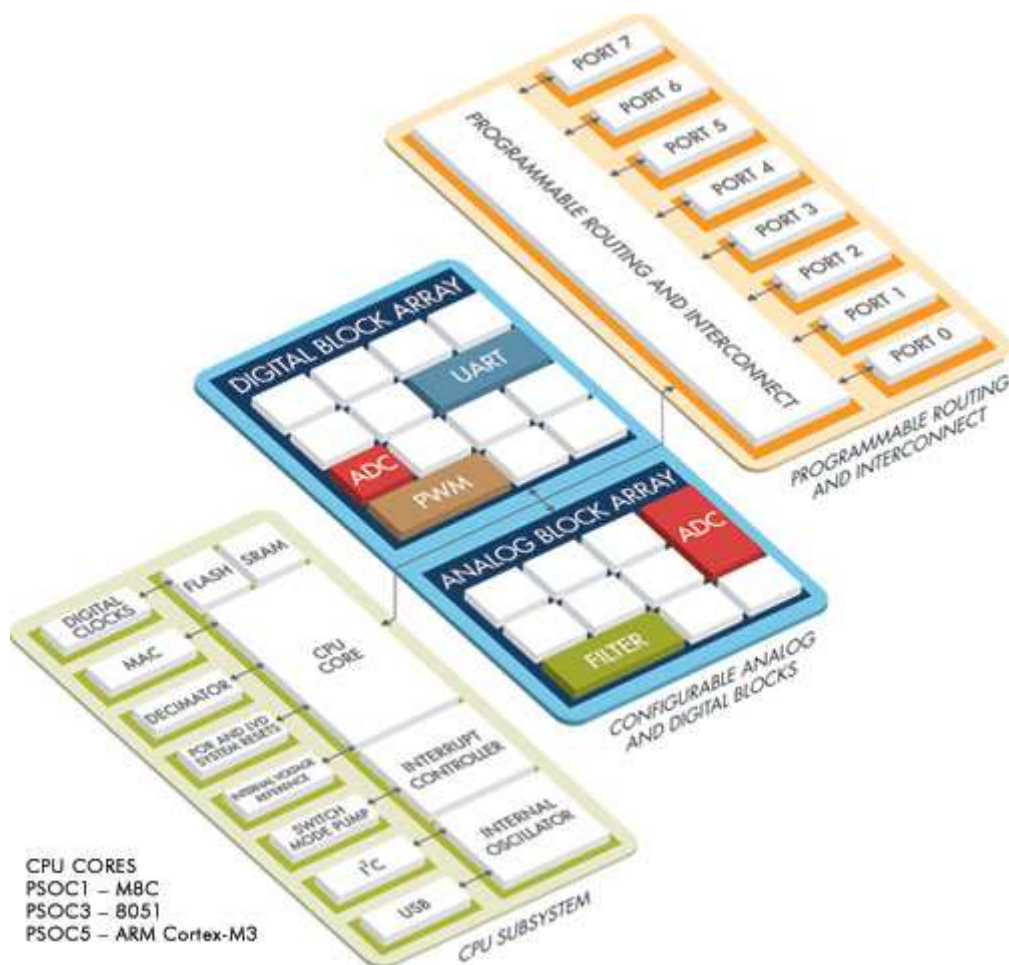

The operating voltage of the micro-controller is 5V and the clock frequency of the CPU is programmed to the maximum frequency, i.e. at 24 Mhz. In the SARK100 project it have been implemented the following programmable functions:

Function	Type	Description
ADCINC12	12-bits Incremental ADC	This is the basic component for measurement of the branches of the reflectometer. Converts the voltage level of the selected branch of the bridge and converted to a digital value. Operates at a 6MHz clock so the sampling time is 360 samples per second. The input range is 0 to 5 V
AMUX4_ADC	4:1 Analog Multiplexer	This feature allows you to select under program control the branch of the bridge to measure (VF, VR, VA, or VZ).
E2PROM	EEPROM Emulation	This is a function provided by the PSoC Designer that lets you emulate the operation of a flash EEPROM memory using the PSoC program flash memory. It is used for storing the calibration data and user settings.
LCD	LCD Control Library	This is a function provided by the PSoC Designer that provides a driver and an API for controlling a character display
PGA_ADC	Programmable Gain Amplifier	This amplifier is placed between the analog multiplexer and the ADC and allows the signal level conditioning of the reflectometer to the full scale of the ADC. The branches VF, VZ, and VA are amplified with a level of 2.67 and the VR branch with a level of 5.33 (double as other branch).
PGA_DDS_1 PGA_DDS_2	Programmable Gain Amplifier	These amplifiers are used to simulate a DAC function and control the output level of the DDS. These amplifiers are continuous type of PSoC blocks so they are less noisy than an actual DAC, which is switched and generates noise that modulates the signal.
PWM8_BUZZ	Programmable Width Modulator	It is used to generate the signal to sound the buzzer. The clock source is the 32Khz internal clock.
Timer16_Delay	16-bits Timer	It is used to implement delays of short duration. The clock source is the 32Khz internal clock.
UART	UART	It is used for communication with the PC via the USB serial converter. The clock source is directly the system clock, 24 MHz, and a divider 52 to generate the speed of 57600.

The board provides the connector JP3 to allow in-circuit programming. This functionality will not normally be used by end users as the PSoC kit comes pre-programmed and can update the software via USB.

The keypad is a 2x3 matrix and is controlled by input/output ports of the PSoC. The DDS, the display and backlight control are controlled in the same way with input/output ports.

Power Supply

The design integrates a sort of regulators to allow operation from both battery and external power supply and also implements a battery charger. The battery consists of 8-cell AAA format NiMH 1000 mAh capacity in series, for which the nominal voltage is 9.6 V.

The battery charger is constant current type and has no control of end of charge so it has been designed to load below 0.1 C (100mA) to avoid the damaging the battery. This greatly simplifies the circuit charger but the charging time will be longer. The charger circuit requires a minimum input voltage of about 13.5 V to allow the full charge.

The 12V regulator, U11, works as a preregulator when using the external power supply. The power amplifier has a maximum supply rating of 12.6V so this regulator is strictly needed to allow the charge of the batteries while not damaging the amplifier. Besides this reduces the temperature of the 5V regulator, U6.

Reflectometer

The reflectometer is basically an absorptive SWR bridge fed by the DDS signal which in turn is driven to the antenna. The voltages provided by the reflectometer are digitized and used by the microcontroller to calculate the SWR and impedance values at the selected frequency.

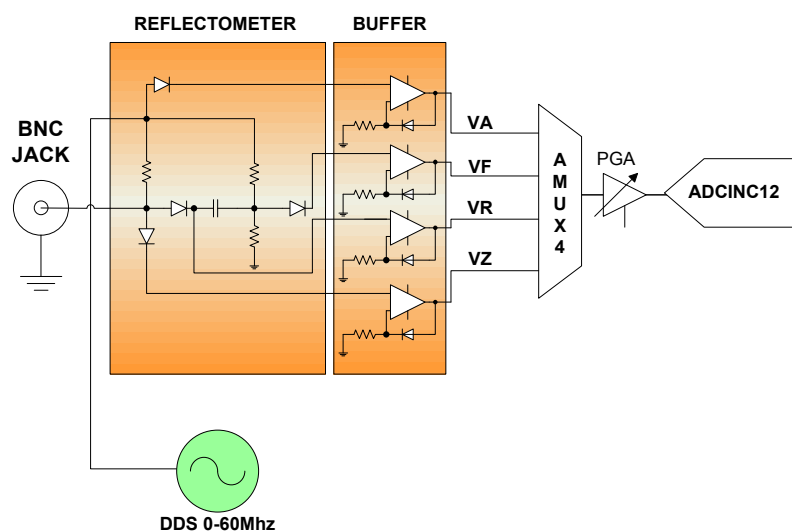

The reflectometer is a Wheatstone bridge consisting of 50 Ω resistors being the antenna the unknown impedance of the bridge. When the antenna is in resonance, i.e. a resistive impedance of 50 Ω and no reactance, the bridge is balanced and AC voltages on each side of the bridge are identical. That is, no AC current flows through the legs. However, when the antenna is not resonant, the complex impedance is not 50 Ω which create a bridge imbalance.

The analyzer measures four voltages of the bridge for impedance calculations. The incident voltage (VF), the reflected voltage (VR), the voltage at the antenna (VZ), and the voltage across the known resistance of the leg of the load (VA). The measurement is performed with envelope detectors implemented in this case with Schottky diodes and a compensation buffer. This buffer

stage compensates the nonlinearity of the transfer curve of the diode, thus improving the accuracy of measurements. Furthermore, this design uses paired diodes which improves accuracy.

The diodes, HSMS-2805 Avago Technologies, has been selected with a breakdown voltage of 70V to provide better reliability. It has a slightly lower performance than the HSMS-2825, which is ideal for RF detection function, but the latter has a low breakdown voltage (15V) and it will be more sensitive to disturbances. The design incorporates a gas discharger low voltage to prevent equipment damage in case of static.

USB Serial Converter

The USB interface is provided by a USB to serial converter from FTDI, the FT232RL. The chip requires virtually no external components so the design is extremely simple. In this design has chosen not to be powered from the USB bus.

15 Theory of Operation – Software

The operation of the SARK100 is completely software controlled and the software running on the PSoC micro-controller. The program has been fully developed in 'C' language and it is open source so you can study it in detail and modify and evolve it at your convenience. The program also includes a bootloader that allows field upgrades through the USB connection.

The operation of the program is based primarily on a main loop that is responsible of polling the key buttons and make periodic measurements. There is a periodic interrupt for the control of the program timings. In the main loop it is used the Sleep processor mode in order to reduce the controller power consumption during the wait times.

All calculations are performed with integer arithmetic because floating-point calculations consume more processor resources. Usually a precision of 32-bits is enough for most of the calculations but for the DDS control register setting it has been necessary implementing 64-bit multiply and divide routines.

Memory Management

In a micro-controller it is very important to be aware of the device limitations. The PSoC part used in the SARK100 has a total of 32KB of flash and 2KB of SRAM. Part of the flash is used for the bootloader and other (384-bytes) is used for the EEPROM emulation, so in total there are **29184 bytes** available for the program logic.

As a referente the version 07 of the SARK100 software uses 27763 bytes of flash plus 724 bytes of RAM (without the stack). We must take into account this when creating future developments.

Program Modules

Main.c

Almost the entire control of analyzer is done from this module. Includes the initialization and the main loop control. The main loop basically polls periodically the keyboard waiting for user actions, monitors timings, and performs the measurements. In case of user action the program will react accordingly, for example, changing the frequency, so and so. Two timers are monitored basically, the user idle time detection and the time between measurements.

DDS.c

This module provides the DDS driver. This module expects the frequency value in Hertz and the driver programs the DDS registers accordingly. The translation of frequency value to the DDS control word requires extended precision so this driver implements 64-bit multiply and divide routines.

Calcs.c

This module implements the calculation routines for SWR, Z, R, L, and C; using the results of the measurements of the analog to digital converter. The

Este módulo proporciona las rutinas de cálculo de ROE, Z, R, X, L, y C; utilizando los resultados de las medidas del convertidor analógico digital. The used formula are the following:

$$ROE = \frac{VF + VR}{VF - VR} \times 100$$

$$Z = 50 \times \frac{VZ}{VA}$$

$$R = \frac{(2500 + Z^2) \times ROE}{50 \times (SWR^2 + 1)}$$

$$X = \sqrt{Z^2 - R^2}$$

$$L = \frac{10^6 \times X}{2 \times \pi \times F}$$

$$C = \frac{10^{12}}{2 \times \pi \times F \times X}$$

$$\phi = a \tan\left(\frac{X}{R}\right) \times \frac{180}{\pi} \text{ (not yet implemented)}$$

The sign of the reactance is determined by a frequency shift technique. The reactance value at the measurement frequency is compared with the value at a slightly higher frequency. If the reactance value is higher the most likely is an inductive reactance (+j). If the reactance value is lower the most likely is a capacitive reactance (-j).

Calibrate reflectometer.c

It implements the calibration procedures. The calibration is necessary to compensate the non-linearity of the diode detectors, the offset values between the bridge legs, and the frequency dependent effects of the bridge components. The calibration starts by adjusting the signal power level for each band in order to compensate the roll-off effect of the DDS.

The instrument implements a two-point calibration technique for each bridge leg, i.e. that they are used two different load values to derive the calibration factors. From these values they are calculated of gain and offset which are stored in the EEPROM for each band. For the impedance measurements, VZ and VA, it uses the 50 and 150 Ω loads. For SWR adjustments it uses the 150 and 274 Ω loads.

Util.c

It implements some utility functions such as delays, conversion functions, etc.

Measure.c

This is the driver of the analog to digital converter and so where the legs measurements are performed. For each bridge leg it is selected the right multiplexer input, it is adjusted the gain of the input amplifier, and then it is performed an acquisition of the analog to digital converter.

For the measurement it is implemented the "Correlated Double Sampling" technique that consists in taking a dummy measurement with the input shorted and then perform the real measurement. The read value is subtracted from the dummy value so compensating the offset and noise effects. In addition the measurement it is performed four times and averaged in order to further minimise noise.

Display.c

Manages the presentation in the LCD display of the frequency and of the different impedance modes.

Keypad.c

Performs the scanning of the matrix of key buttons. Implements debouncig routines and manages the specific operation of the frequency change keys.

Sleep_timer.c

Periodic interrupt that runs 8 times per second. Updates the timers for the main loop and equipad routines.

Storage.c

Manages the storage of calibration factors and the instrument configuration parameters in EEPROM.

Glb_data.c

Centralizes all global data.

Msg_eng.c

Includes all texts to be displayed, in this case in English language. You can customize or adapt to another language.

Buzzer.c

Implements the buzzer device driver.

PClink.c

Implements the command interface when the analyzer is controlled from the PC.

Appendix A: Schematics

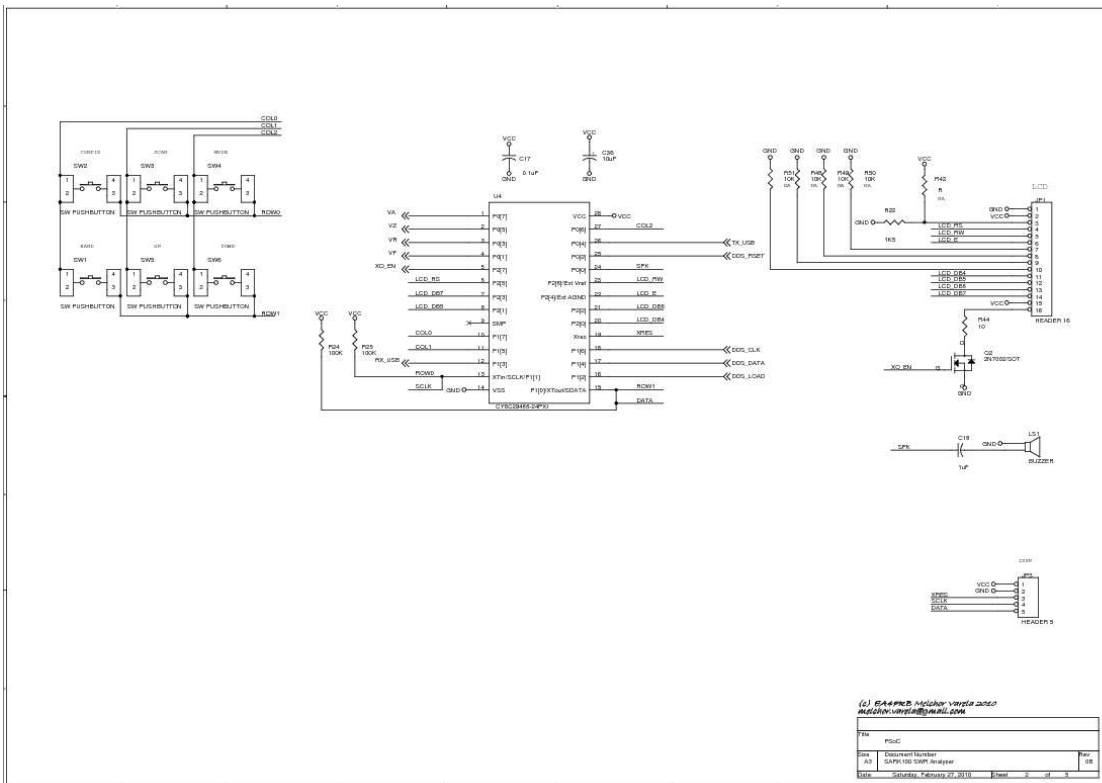
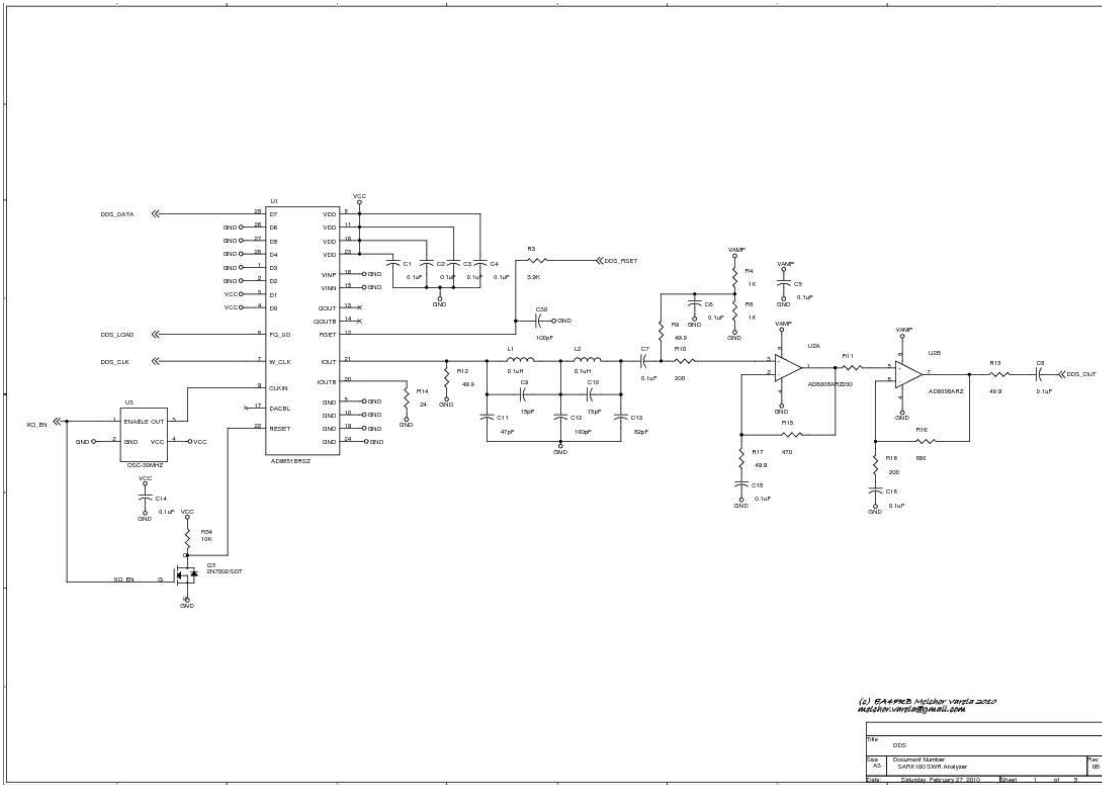

Appendix B: Part List

Quantity	Reference	Part
19	C1, C2, C3, C4, C5, C6, C7, C8, C14, C15, C16, C17, C27, C28, C31, C35, C37, C40	0.1uF
2	C9,C10	15pF
1	C11	47pF
6	C12,C30, C19, C22, C21,C25	100pF
1	C13	82pF
4	C18,C29,C36,C39	1uF
4	C20,C23,C24,C26	10nF
1	C38	10uF
4	D1,D2,D3,D4	HSMS-2805
3	D5,D6,D7	B340A-13-F
1	JP1	HEADER 16
1	J1	BNC JACK
1	J2	MINI B USB
1	J3	POWERJACK
1	LS1	BUZZER
2	L1,L2	0.1uH
2	Q2,Q3	2N7002/SOT
1	R3	3.9K
2	R8,R4	1K
7	R9,R12,R13,R27,R28,R30,R17	49.9
3	R10,R11,R18	200
1	R14	24
1	R15	470
1	R16	680
1	R22	2K7
2	R25,R24	100K
4	R26,R32,R35,R38	47K
4	R29,R33,R36,R39	1M
4	R31,R34,R37,R40	220K
1	R43	12
1	R44	10
2	R53,R54	10K
1	R52	4.7K
6	SW1,SW2,SW3,SW4,SW5,SW6	SW PUSHBUTTON
1	SW7	SWITCH POWER
1	U1	AD9851BRSZ
1	U2	AD8008ARZ
1	U3	OSC-30MHZ
1	U4	CY8C29466-24PXI
1	U5	TLC279/SO or LMC6484IM
1	U6	L7805
1	U8	FT232RL
1	U9	LM317
1	U10	SURGE ARRESTER 75V
1	U1	MC7812

Appendix C: Component Layout

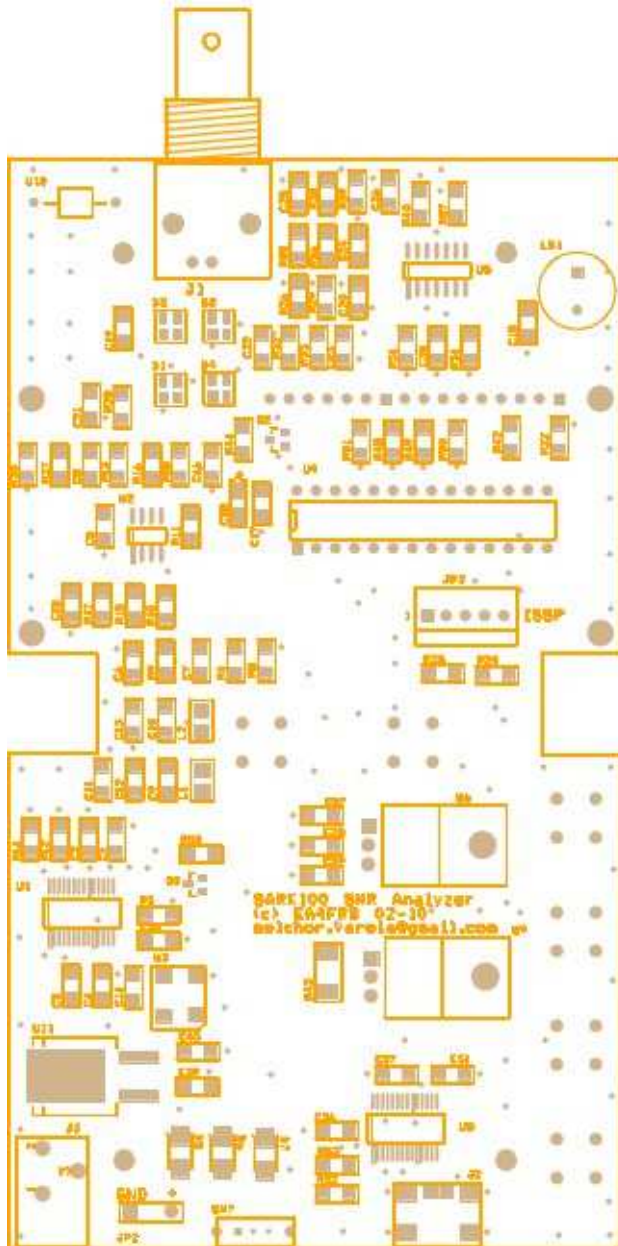

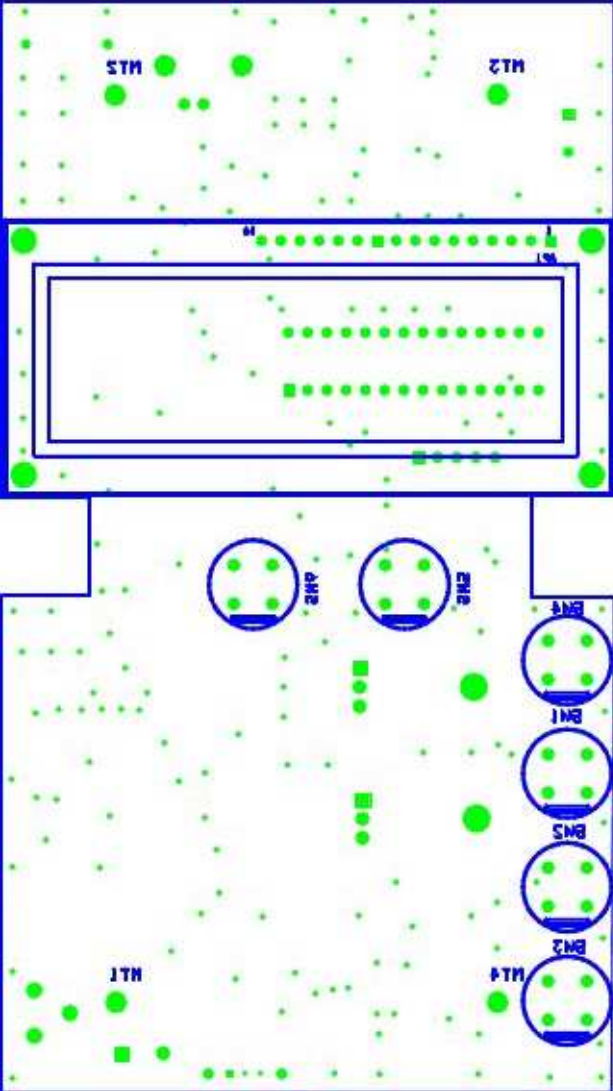

Appendix D: Enclosure Diagrams

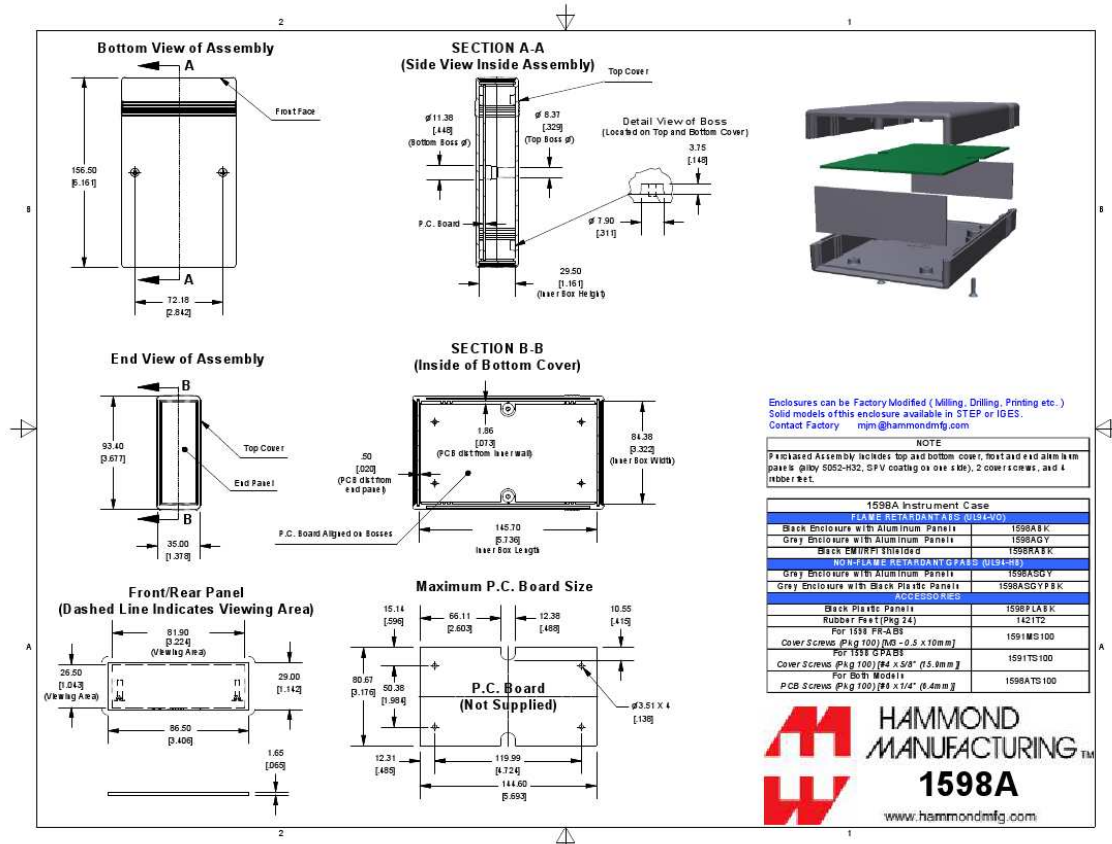

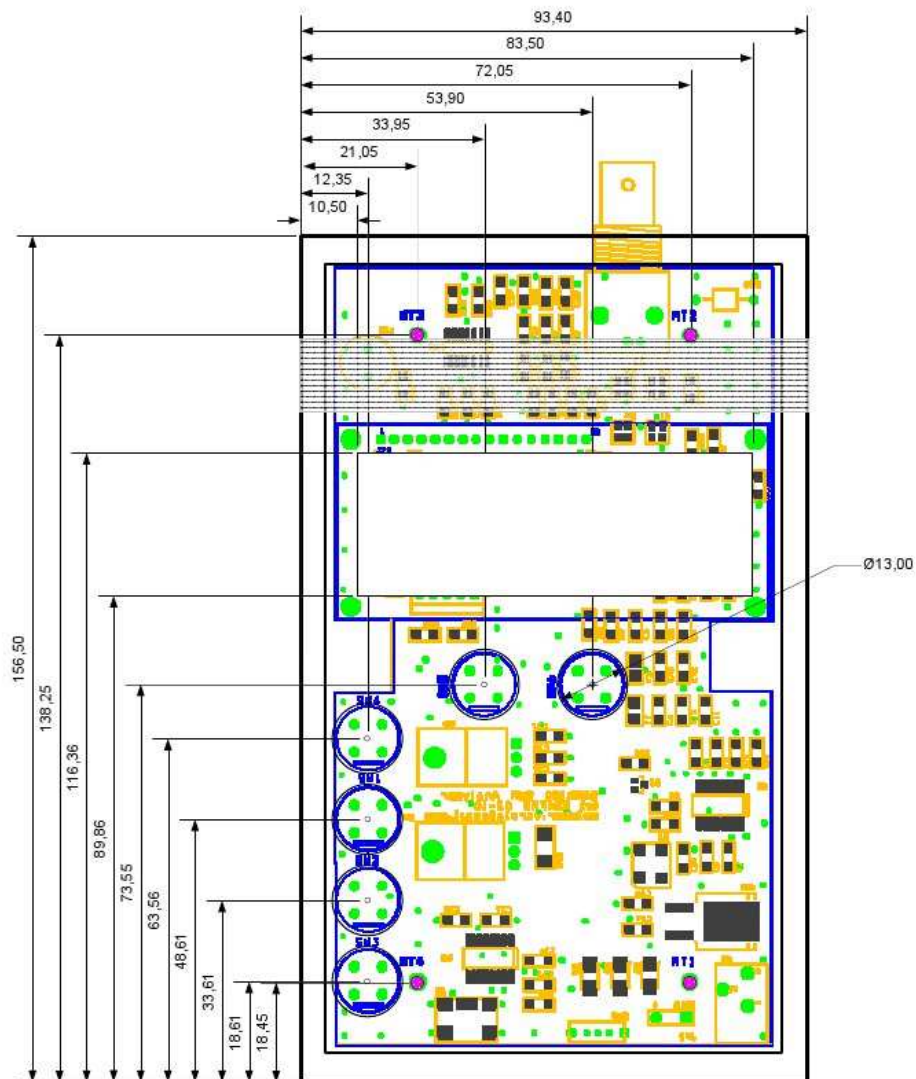

SARK100 SWR ANALYZER
 © EA4FRB Melchor Varela 2010

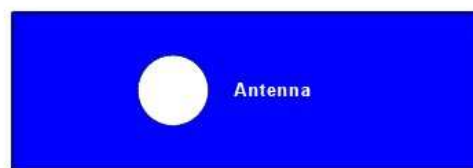
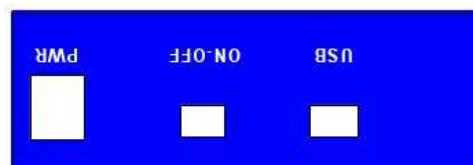
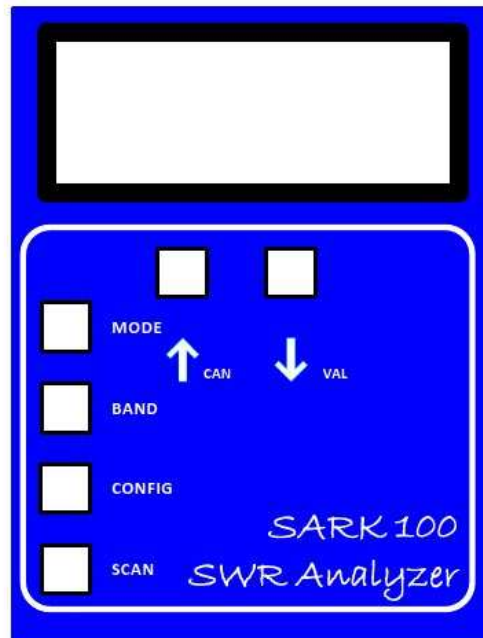

SARK100 SWR ANALYZER
© EA4FRB Melchor Varela 2010

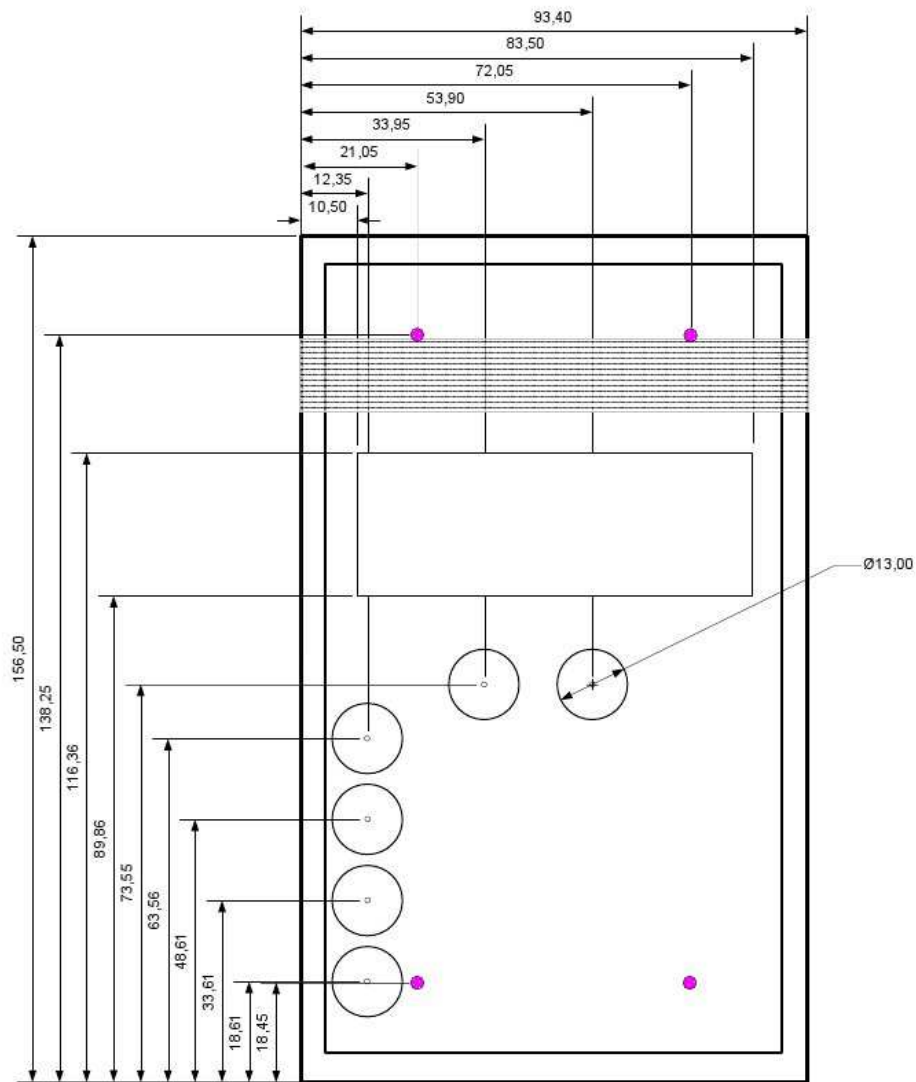

SARK100 SWR ANALYZER
 © EA4FRB Melchor Varela 2010

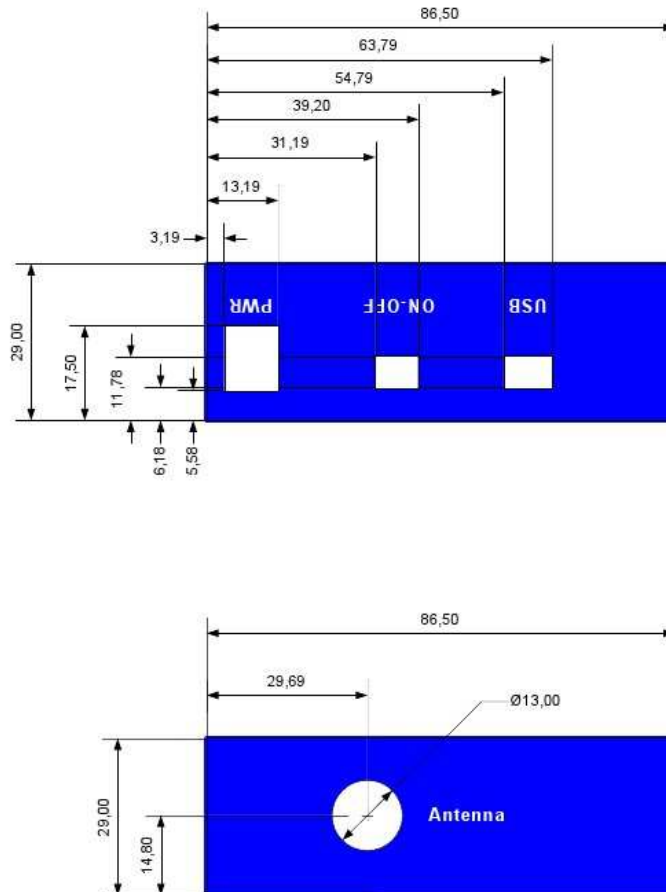

SARK100 SWR ANALYZER
© EA4FRB Melchor Varela 2010

Appendix E: USB Driver Installation

The SARK100 incorporates a USB interface for PC connection. This interface is implemented by the FTDI Chip FT232R chip which requires prior installation of a driver "Virtual COM Port (VCP) available at the following link:

<http://www.ftdichip.com/Drivers/VCP.htm>

This driver is available for multiple operating systems on which you access the manufacturer's website and select the appropriate driver, always bearing in mind that the chip is the FT232R. Preferably you install by using the "setup executable" and following the manufacturer's instructions.

Once installed and connected the SARK100 you can verify proper installation by entering in the Device Manager of the Windows Control Panel. By connecting the SARK100 you should see a new COM port with the FTDI driver reference. Please note the COM port name as it will be necessary to know to use the SARK100 from your PC, eg for software updates or to control the instrument from HyperTerminal.

Appendix F: Updating the Analyzer Software

The analyzer software is upgradeable via USB, so the analyzer can be updated with the latest software available on the website of the product, or you can even customize the code by using the free PSoC Designer tool.

For the software update will need a PC running Windows and a USB cable (not included). The loading program: TerminalProgram_v2.zip is available on the project website. Unzip the zip file in a directory of your convenience and create a shortcut on the desktop to have it available for use.

Procedure

1. Download from the project website the firmware file to a known directory, e.g. the Windows Desktop. If you have created the software with PSoC Designer, you will find it in the project root directory
2. Connect your PC to the SARK100 using the USB cable. It is highly recommended power the SARK100 by an external power supply to make sure you don't run out of power during the update process
3. Check in the PC Device Manager that the PC has correctly recognized the port and note the COM port number. This example uses the COM6
4. Run the program on the PC. You should see a screen like the following:

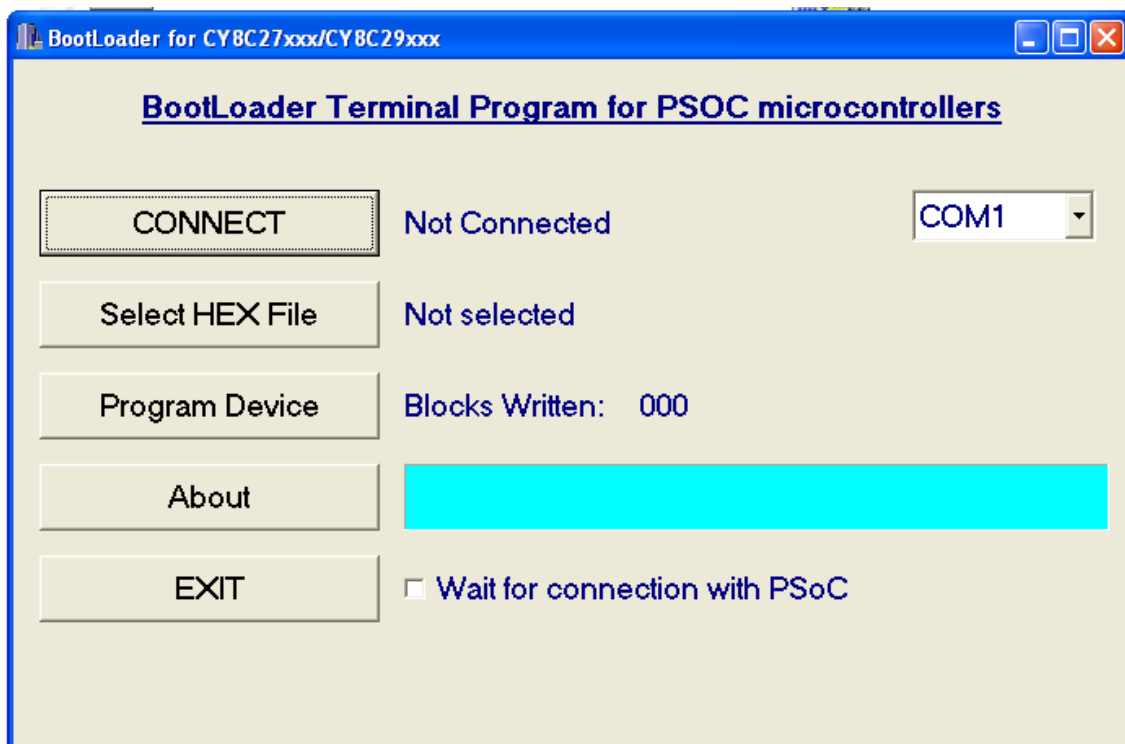

5. Select the communication port, in this example COM6, from the drop-down list on the right. Pressing the button [Select HEX File] and select the file to load, in this example SARK100_SwrAnalyzer_BL.hex. Finally check the tab "Wait for connection with PSoC". At this time the program is ready for synchronization with the SARK100. The resulting screen in this state is as follows:

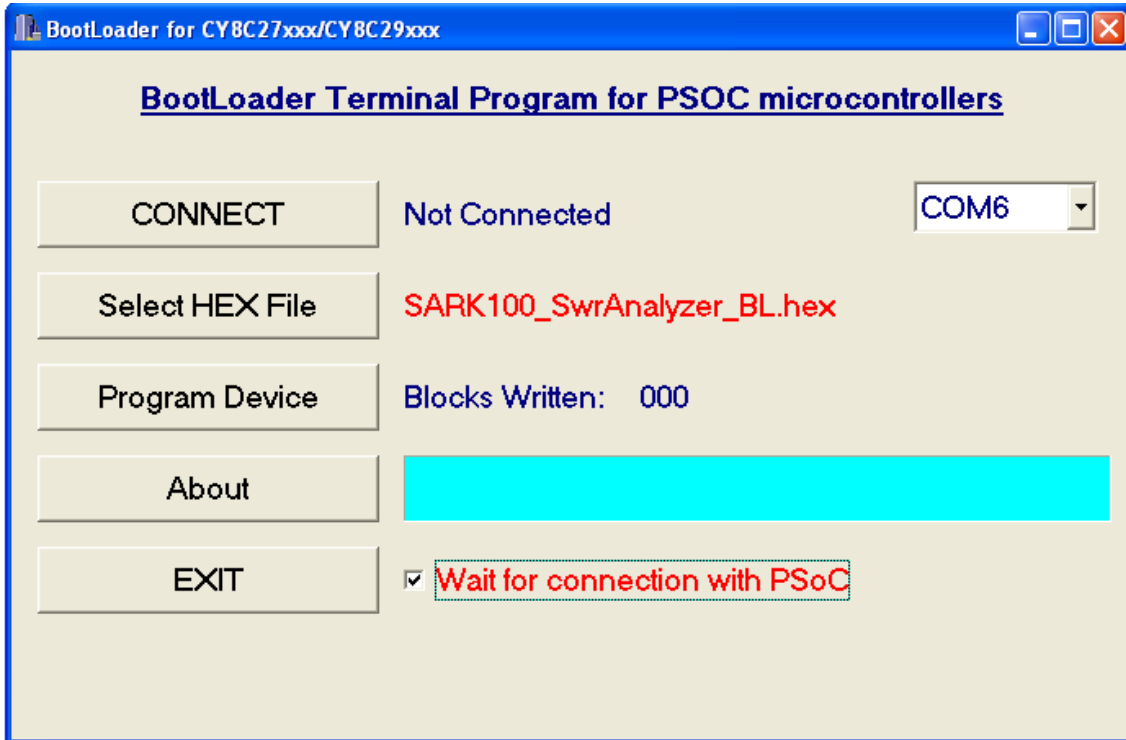

6. Now in the SARK100 go the CONF menu and select the option "Load Software" and click VAL. You will be prompted for confirmation and after confirm by pressing VAL, the PC program should detect the synchronization and display the text "Connected" to the right of the [CONNECT] button
7. At this point the connection was made and it is a matter of pressing the [Program Device] button and wait until the end of the load. The progress of the load will be show in the status line and it is important not interrupting the charging process. At the end of the process the SARK100 will restart and will display the new version of the software
8. The loading process erases the stored parameters including calibration data and it would be advisable to recalibrate the instrument

Appendix G: Calibrating the Analyzer

To improve the accuracy of the analyzer this should be calibrated. This is a simple procedure that just requires loads of known value and follows the outlined procedures. The calibration data is stored in nonvolatile memory and will remain stored during the life of the instrument. Recalibration will be necessary in the case of a software update because the stored calibration data are lost during the loading process.

It is essential to properly implementing the loads by integrating in BNC connectors and minimizing the length of the connections. Another method is to use a BNC to RCA adapter and mount the resistors in RCA connectors, as they are cheap and easy mounting of resistors, as shown in the following illustration:



The instrument normalizes the gains of the four legs of the bridge for the different bands of operation, creating the correction values to be stored in nonvolatile memory. These correction values are calculated for different load conditions during the calibration process and are subsequently used for measures to compensate for gain differences of the legs of the bridge.

Calibration Procedure

1. Select the "Calibrate" on the setup menu
2. The instrument will prompt the user with the LCD text "Disconnect Load", indicating to remove any load from the RF connector. Press the button VAL after disconnecting the load and then the display will show "In Progress..." indication that calibration is in progress
3. Then it will prompt to connect a 50 Ω load "Conn 50 Ω Load". Plug the 50 Ω load and then press VAL. The display will show "In Progress..." indication that calibration is in progress
4. After that it will prompt to connect a 150 Ω load "Conn 150 Ω Load". Plug the 150 Ω load and then press VAL. The display will show "In Progress..." indication that calibration is in progress

5. Subsequently it will prompt to connect a 274 Ω load "Conn 274 Ω Load". Plug the 274 Ω load and then press VAL. The display will show "In Progress..." indication that calibration is in progress
6. Once the calibration is finished it will show the text "Done". This means that the calibration process has been completed and stored in the EEPROM. Just press VAL to continue

Appendix H: Making a Dummy Antenna for Testing

It may be desirable to have a dummy antenna for testing the SARK100. A dummy antenna is simply a three-component circuit that is resonant at a specific frequency and has a purely resistive characteristic at the resonance frequency. The dummy antenna can be used in place of a real antenna during initial testing of the instrument.

The dummy antenna consists of one resistor, one inductor and a capacitor in a series circuit, built at the end of a BNC connector that can be connected to the SARK100 antenna. The table below shows the component values for dummy antennas to any of the specified frequencies:

Freq (Mhz)	C (pF)	L (uH)	Core	#Turns
7.1	82	6.8	T50-2	37
10.1	47	5.28	T50-2	33
14.1	27	4.7	T50-2	31
18.1	22	3.51	T37-2	30
21.2	27	2.08	T37-2	23
28.5	15	2.08	T37-2	23

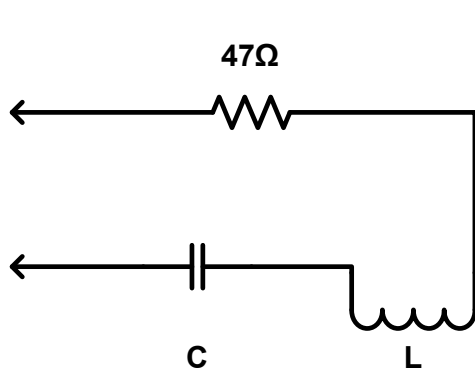

Single Resonance

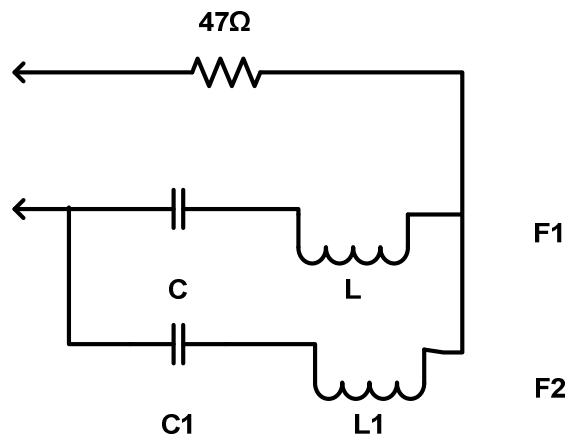

Double Resonance

Appendix I: PC Command Interface

Command	On
Description	Enables DDS signal generation. Requires setting correct DDS frequency
Arguments	--
Response	OK
Error response	Error: freq not set
Example	>>on OK

Command	off
Description	Disables DDS signal generation
Arguments	--
Response	OK
Error response	--
Example	>>off OK

Command	freq
Description	Sets DDS frequency
Arguments	{frequency} Frequency in Hertz
Response	OK
Error response	Error: invalid freq
Example	>>freq 14070000 OK

Command	imp
Description	Get impedance values
Arguments	--
Response	{SWR},{R},{X},{Z}
Error response	--
Example	>>imp 1.05,52,10,51

Command	raw
Description	Get raw bridge voltages
Arguments	--
Response	{Vf},{Vr},{Vz},{Va}
Error response	--
Example	>>raw 257300,165500,31800,214500

Command	scan
Description	Scans from specified start to end frequency and get impedance values
Arguments	{freq_start} Start freq. in Hz {freq_end} End freq. in Hz {step} Step in Hz
Response	Start {SWR},{R},{X},{Z} {SWR},{R},{X},{Z} ... End
Error response	<ul style="list-style-type: none"> ▪ Error: expected freq val ▪ Error: expected step val
Example	>>scan Start 1.05,52,10,51 1.05,52,10,51 .. End

Command	Scanr
Description	Scans from specified start to end frequency and get raw bridge voltages
Arguments	{freq_start} Start freq. in Hz {freq_end} End freq. in Hz {step} Step in Hz
Response	Start {Vf},{Vr},{Vz},{Va} {Vf},{Vr},{Vz},{Va} ... End
Error response	<ul style="list-style-type: none"> ▪ Error: expected freq val ▪ Error: expected step val
Example	>>scan Start 257300,165500,31800,214500 257300,165500,31800,214500 ... End

Appendix J: Quick Reference Sheet

