



SOUND RIDER

Front of House:

A quality stereo PA system with sufficient power for the venue should be provided. The system should be able to produce an average of 120 dBA throughout the venue. Such as, L' acoustics, Meyer Sound, D&B or equivalent.

Mixing Desk:

Analogue or Digital mixing desk with a minimum of 2 mid sweeps per channel / 16 channels / 4 Subgroups.

Analogue: Midas, Yamaha, Crest, Soundcraft etc.

Digital: Yamaha, Digico, Digidesign, etc.

In case of monitors being controlled from FOH, the desk needs to have 8 aux sends.

All access to FOH Eq/Processing during soundcheck / Show.

Effects:

2x31-band Graphic EQ of high quality (Klark technik, Ashley or equivalent)

6x compressor/limiter (Dbx, Drawmer or equivalent)

1x tap delay of high quality, preferably D2 2x

reverb of high quality (PCM 96, M2000/3000)

Stage:

Dope D.O.D only uses wireless mic's; they should be of good quality in preferably Shure U4 with Beta 58 mics.

We need:

3 wireless systems **no budget Mic's / Receivers!!**

1 Beta 58 Spare microphone with enough meters of cable to walk around the stage. 2

Technics 1200 MK5 (of proper quality and in proper condition)

1 mic stand for the DJ

1 smoke machine to be controlled from the DJ booth 1 fan to be positioned at the DJ booth.

Please make sure the gain on the mics and receivers are turned down enough so no clipping can occur.

Please make sure there are new batteries for the mics.

Visuals:

We need 1 big screen and 1 beamer or LED wall appropriate enough for the venue. (Bigger venue; bigger screen/beamer/LED wall)

The beamers should be at least 4000 ANSI lumen, so the quality is good enough, we use FULL HD visuals.

There should be an HDMI at the DJ-booth, the DJ will be triggering the visuals from his laptop. The beamer screen should have a ratio of 16:9 and the size, as big as possible for the stage. It should be placed in the middle of the stage and above the DJ (bottom of the screen should be 2 meters high) if the ceiling of the stage is too low to fit a screen above the DJ, please contact our technician at chubeats@gmail.com / Tel: +31641852033

The beamer and screen should be installed and ready too use before the soundcheck!

Monitoring:

Monitors may be controlled from FOH if needed

Mixing board: 16 channels with at least 2x mid sweep EQ per channel. One Group on the front of the stage.

Speakers: 6 floor wedges (or more when necessary) with sufficient power, plus stereo monitoring for the Dj.

All the monitor groups should have a graphic EQ inserted.

If possible, the DJ would like a sub monitor as well.

The DJ would like to be able to adjust his own monitors from mixer (booth output, two channels, 6.3mm Jack)

INPUT LIST

Channel	Source	Mic/DI	Stand	Processor
1	Vocal 1	Wireless		Comp 1
2	Vocal 2	Wireless		Comp 2
3	Vocal 3	Wireless		Comp 3
4	DJ L			Comp 4
5	DJ R			Comp 5
6+7	Booth LR			

Technical questions?

Please, contact Chu Tel: +31641852033 E-mail: chubeats@gmail.com

Timetable and Tour questions?

Please, contact: Jay, +31 6 16627298 E-mail: dopedodenterprise@gmail.com

STAGE PLAN

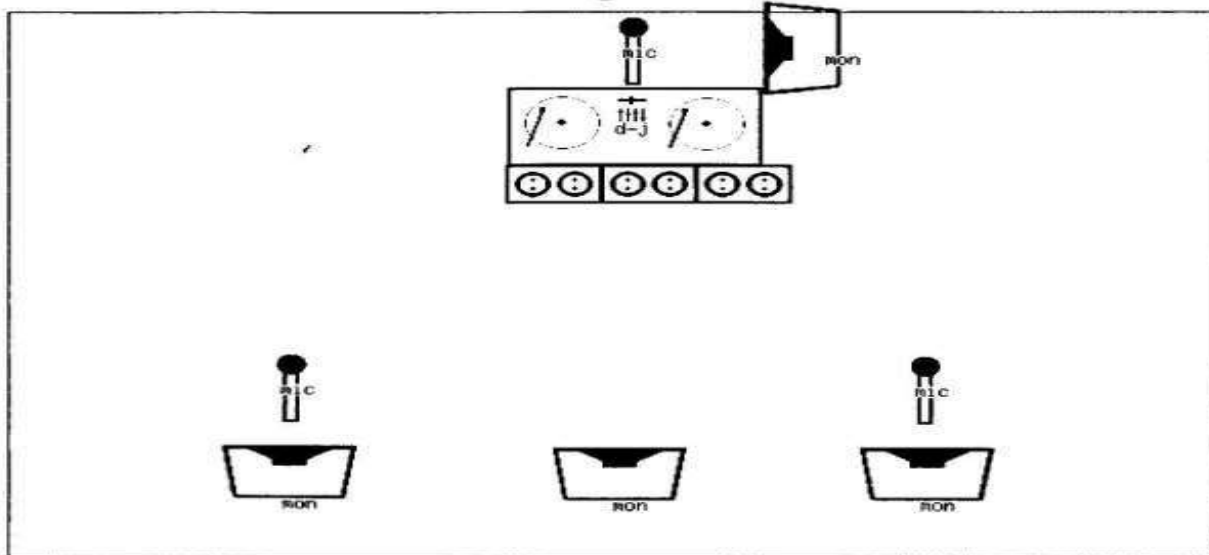

line-up

Skits
Jay

Chu

MC

MC

DJ

monitorgroepen

Version # 01-01-22



