

AIR

**Shara 6** A+

[www.ferlux.es](http://www.ferlux.es)

CHIMENEAS Y BARBACOAS FERLUX, S.A.  
POLIG. INDUST. EL POLEAR, PARC. 1  
29313 VILLANUEVA DEL TRABUCO MALAGA (ESPAÑA)  
TEL. +34 952 03 11 17 FAX +34 952 03 11 18

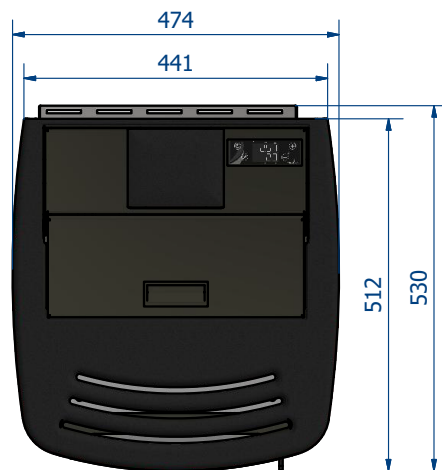
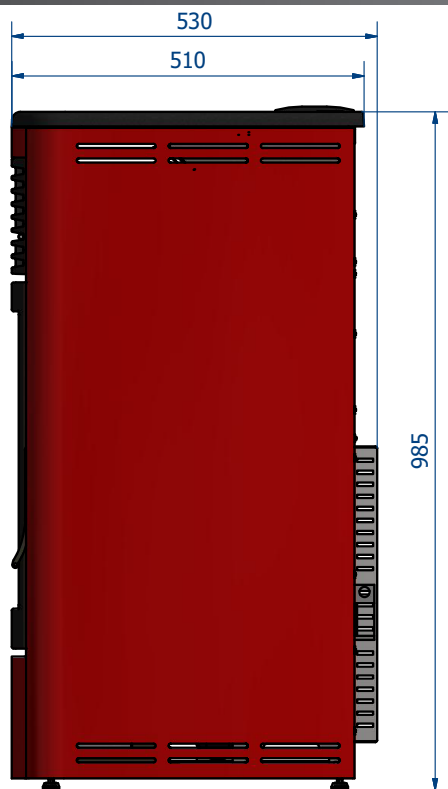

Imperial Red



White Pearl



Marrom Vintage



Black



CHIMENEAS Y BARBACOAS FERLUX, S.A.  
 POLIG. INDUST. EL POLEAR, PARC. 1  
 29313 VILLANUEVA DEL TRABUCO MALAGA (ESPAÑA)  
 TEL. +34 952 03 11 17 FAX +34 952 03 11 18

## Technical data

RATED THERMAL POWER	6,1 KW
AMBIENT THERMAL POWER	6,1 KW
REDUCED THERMAL POWER	2,8 KW
PERFORMANCE P.T.RATED*	90%
PERFORMANCE P.T.REDUCED,**	94%
CONSUMPTION (MIN-MAX)	0,6 KG - 1,4 KG
AUTONOMY (MIN-MAX)	35 - 15 HOURS
EMISSIONS CO TO 13% DE O <sub>2</sub> (P.T.N. - P.T.R.)	0,01% - 0,04%
PARTICULATE - DGC - NOX (13% O <sub>2</sub> mg/Nm <sup>3</sup> )	16 - 30 - 99
TEMPERATURA OF SMOKES (P.T.R. - P.T.R.)	101 °C - 62 °C
HEATABLE VOLUME	150 M <sup>3</sup>
DIAMETER OF SMOKE OUTLET	80 MM
DIAMETER OF PRIMARY AIR INLET	40 MM
WEIGHT	125KG
TANK CAPACITY	21 KG

## Electrical requirements

POWER SUPPLY	220 - 230 V
FREQUENCY	50 - 60 Hz
ELECTRICAL POWER TURNED ON	300 W
AVERAGE POWER ABSORBED	60 W

### Optional accesory:

Vertical gas outlet

