

Product information

Differential pressure control with the Belimo Energy Valve™

Edition 2024-06

Table of contents

Electronic differential pressure control		
	Products	3
Required components for differential pressure control		
	Differential pressure sensor water 22WDP-51.. from Belimo	4
Mode of operation		5
Additional features		
	Easily adjustable setpoint	
	Adjustable flow limitation	
	Adjustable maximum power	6
	Sensor drift compensation	
	Shut-off function	
Purpose of use		7
Advantages		
	System transparency	9
Sizing		
	$C_{v\text{theor}}$ and V'_{max} for differential pressure control with Energy Valve	10
Operating range		
	Maximum flow	
	Minimum flow with flow reduction	
	Behaviour when the minimum flow is undercut	12
	Start-up behavior after the flow has fallen below the minimum flow rate	
Integration		13
Installation		
	Installation 22WDP-51..	14
Commissioning / Value setting		
	Commissioning / Value setting with the web server	15
	Commissioning / Value setting with Belimo Assistant App	
	Value setting with MP-Bus, Modbus or BACnet	16
	Value setting by means of Belimo Cloud	
	Restrictions	

Electronic differential pressure control

In addition to the control modes position control, flow control and power control, the Belimo Energy Valve™ can also be used as an electronic differential pressure controller. This document provides an overview of electronic differential pressure control.

Products

The differential pressure control mode is available for the following devices with DN 15..50:

- ½...2" Energy Valves

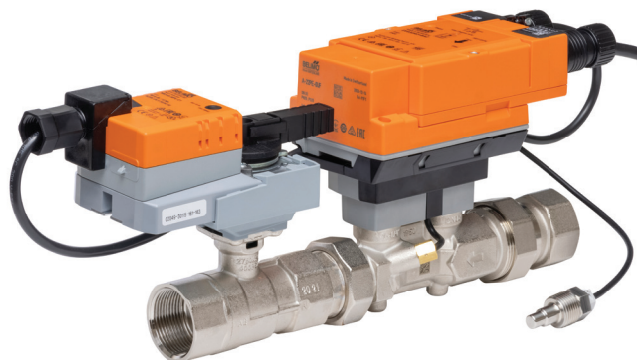

Belimo Energy Valve™

Required components for differential pressure control

If the Energy Valve is used to control the differential pressure, a corresponding differential pressure sensor is needed. This needs to be added as an accessory during the ordering process. The 22WDP-51.. differential pressure sensor is used for differential pressure control. It is available for various measuring ranges and can be obtained from Belimo.

Belimo differential pressure sensor water 22WDP-51..

The sensor is suitable for water and water-glycol mixtures. The housing is made of stainless steel and corresponds to IP65 / NEMA 4. This differential pressure sensor measures the differential pressure that is transferred to a diaphragm integrated in the sensor via two pulse lines (capillary tubes) installed onsite.

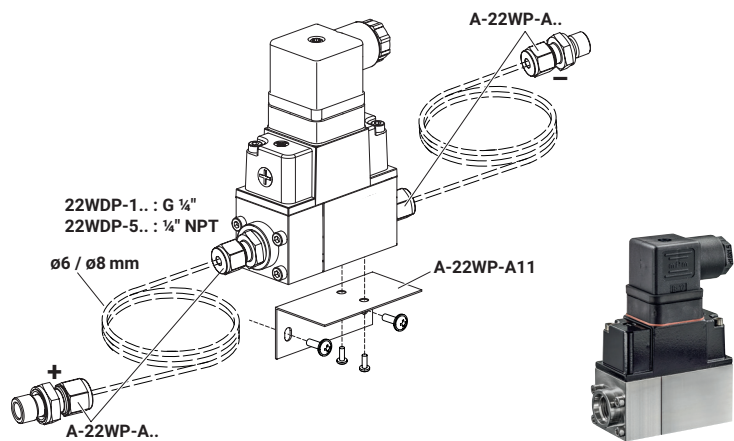

Differential pressure sensor water – 22WDP-51.. from Belimo

Mode of operation

The electronic differential pressure controller is used to maintain the differential pressure (dp) at a constant set value between two points in a hydronic circuit. In addition, it can be used as a flow rate and power limiter.

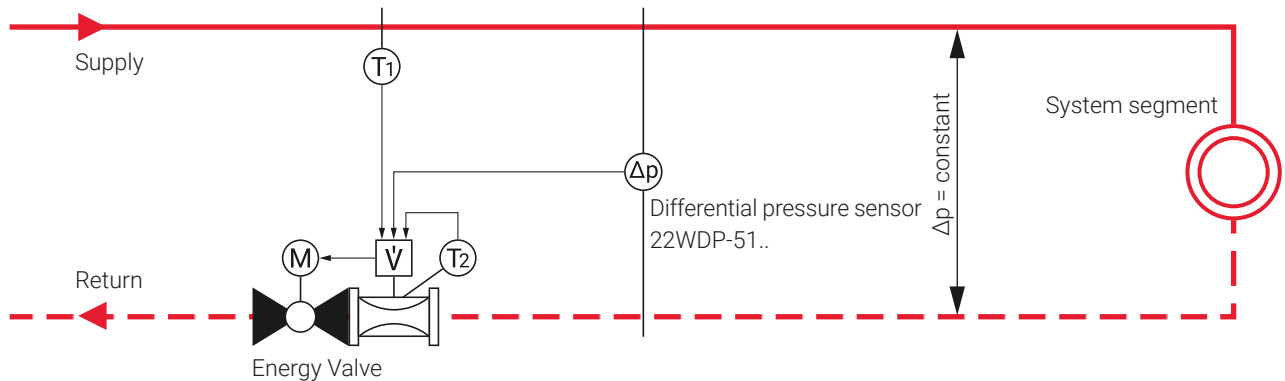

Differential pressure control with Energy Valve

In this operating mode, the Energy Valve does not receive a setpoint from the building management system. The currently existing differential pressure is measured with the differential pressure sensor connected with the Energy Valve. This value is read out of the Energy Valve and compared with the preset setpoint. If a deviation is detected between the measured value and the setpoint, this is compensated automatically by the logic integrated in the Energy Valve. To accomplish this, the opening angle of the characterised control valve integrated in the Energy Valve is either enlarged or reduced. The following three operating states can occur:

1. Effective differential pressure less than the differential pressure setpoint

To reduce the pressure drop across the Energy Valve and thus increase the differential pressure between the measuring points, the valve is opened further until the setpoint is reached. If the differential pressure on the system side is not sufficiently high, the setpoint may not be reached. In this case, the Energy Valve moves to the maximum opening position of 90°.

2. Effective differential pressure corresponds to the differential pressure setpoint

No action of the Energy Valve. The opening position is retained.

3. Effective differential pressure greater than the differential pressure setpoint

To reduce the differential pressure between the two measuring points, more pressure drop must be generated across the Energy Valve. In this case, the valve opening is reduced until the setpoint or minimum position is reached. The ball valve installed in the Energy Valve is never completely closed during standard differential pressure control mode in order to ensure that changes in the system (change in pump head or flow changes due to controlling consumer valves) can be detected.

Additional features

Easily adjustable setpoint

The desired setpoint is simple to adjust on the device. Various options are available:

- Belimo Assistant App, simple communication with the Energy Valve thanks to NFC
- Web server integrated in the Energy Valve, accessible via direct connection or through a network
- Belimo Cloud, value change from anywhere
- Communicative, value change via MP-Bus, Modbus or BACnet

Adjustable flow limitation

A maximum flow V'_{\max} can be specified for the Energy Valve. Even if the effective differential pressure is below the setpoint, the Energy Valve does not open further when V'_{\max} is reached. This makes it possible to avoid situations in which other parts of the hydronic system have too little energy at their disposal.

Flow limitation adjustment range: $V'_{\max} = 25\% \dots 100\%$ von V'_{nom}

Adjustable maximum power

A maximum power Q'_{\max} can be specified for the Energy Valve. The valve position is not increased further when the set maximum heating or cooling power is reached. This setting can be used as a simple way to ensure that the controlled system segment is not able draw too much power.

Maximum power adjustment range: $Q'_{\max} = 1\% \dots 100\%$ Q'_{nom}

Sensor drift compensation

After a longer operating time, a drift can occur at the differential pressure sensor, which can be compensated for as follows:

1. Close the Energy Valve completely (web server, Belimo Assistant App, manually)
2. The measured differential pressure is displayed (web server, Belimo Assistant App)
3. Measure the existing differential pressure at the measurement points (additional system-side measurement connections necessary)
4. Calculate and enter the required offset (web server, Belimo Assistant App)

Shut-off function

If necessary, the characterised control valve integrated in the Energy Valve can be closed completely (lever, web server (automatic reset after 2 hours), communicative override control). The characterised control valve ensures an air-bubble tight shut-off.

Purpose of use

The best results can be achieved by using a pressure-independent control valve at each coil.

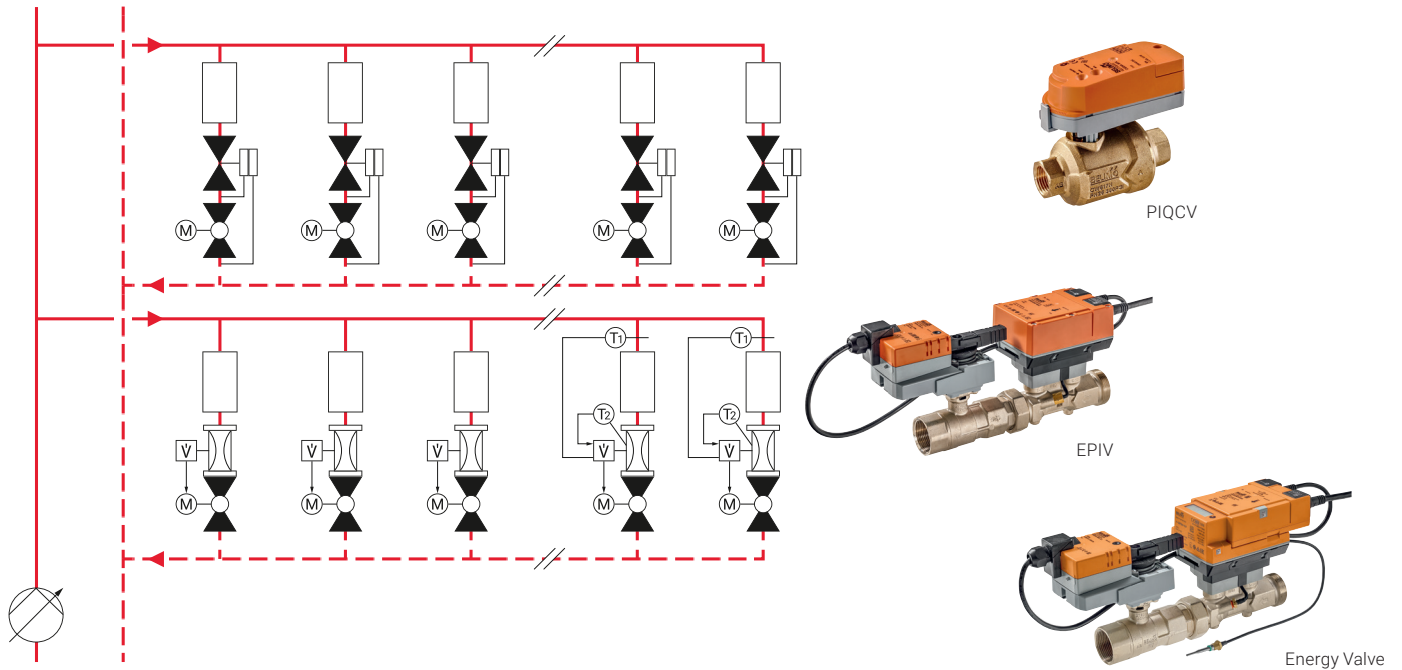

The differential pressure control function of the Energy Valve is not required in this application.

However, if the balancing at the individual coils is only static, the various system segments can be dynamically balanced by using additional Energy Valves with differential pressure control function.

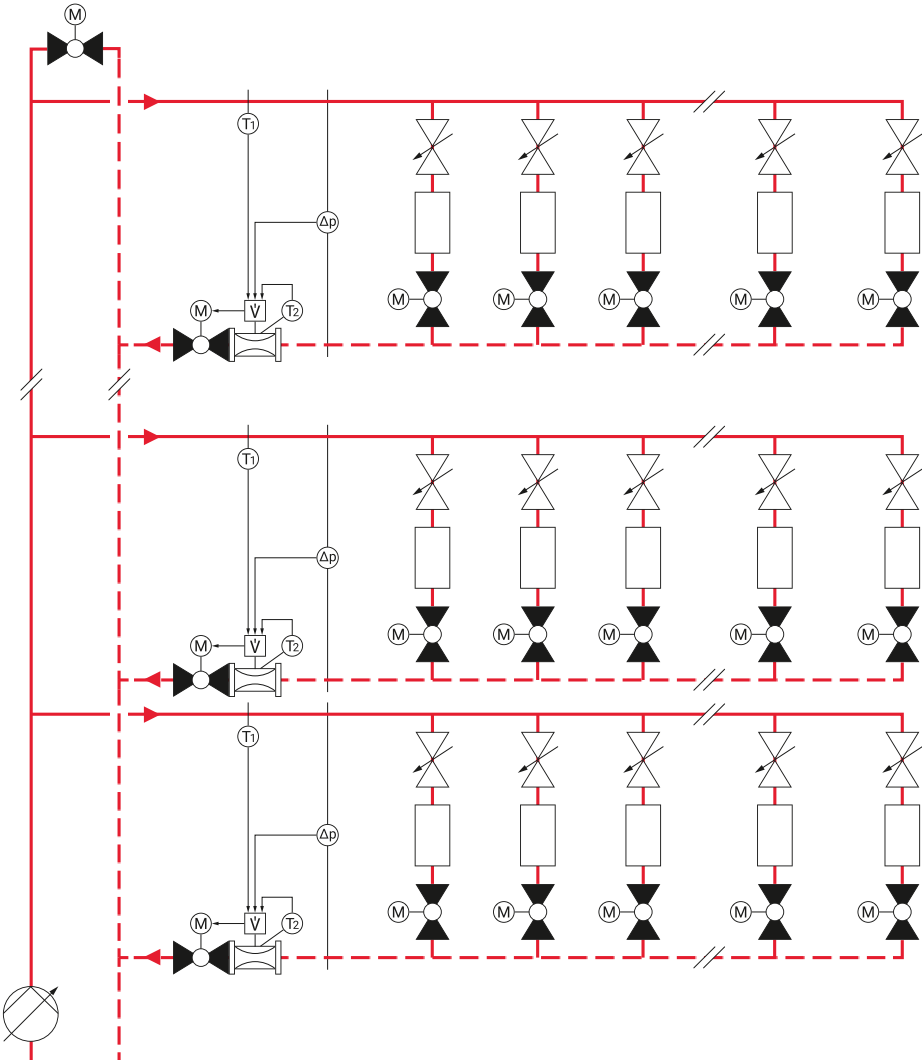

Dynamic balancing of the system segment (building floor) and static balancing of the coils

Advantages

Keeping the differential pressure in a system segment constant makes it possible to avoid excessive flow rates. Possible losses in comfort and energy waste due to oversupply are also reduced.

System transparency

The flow and the supply and return temperature are measured in real time. This enables calculation of current power output and current energy consumption. The Energy Valve thus contributes to system transparency. The saved and readily accessible information (Belimo Assistant App, web server, Belimo Cloud) enables evaluation and optimization of the hydronic system. The transparency achieved also greatly simplifies troubleshooting in the hydronic system

Additional benefits over conventional mechanical differential pressure controllers are achieved by using the electronic differential pressure controller design:

- Eliminates the need to find and adjust the setting position on the differential pressure controller; simple, direct setpoint input
- No access to the differential pressure controller required to change the setpoint; setpoint change possible via MP-Bus, Modbus, BACnet or Belimo Cloud
- No measuring device required to measure system values; permanent measurement of differential pressure, flow and fluid temperatures and easy data access via communicative interface, Belimo Assistant App, web server or Belimo Cloud

Sizing

If the Energy Valve will be used to control the differential pressure, then an additional differential pressure sensor is needed. This is not included in the scope of delivery of the Energy Valve.

Sensor Part Number	Measuring Range (psi)	Differential Pressure Set Point Range (psi)
22WDP-511	0...15	1.5...12
22WDP-512	0...30	3...24
22WDP-514	0...50	5...40
22WDP-515	0...100	10...50

As described in the chapter Functionality, the Energy Valve in differential pressure control mode adjusts its Hydraulic resistance by changing the valve opening so that the pressure drop across the Energy Valve occurs that is required to achieve the desired differential pressure between the measuring points.

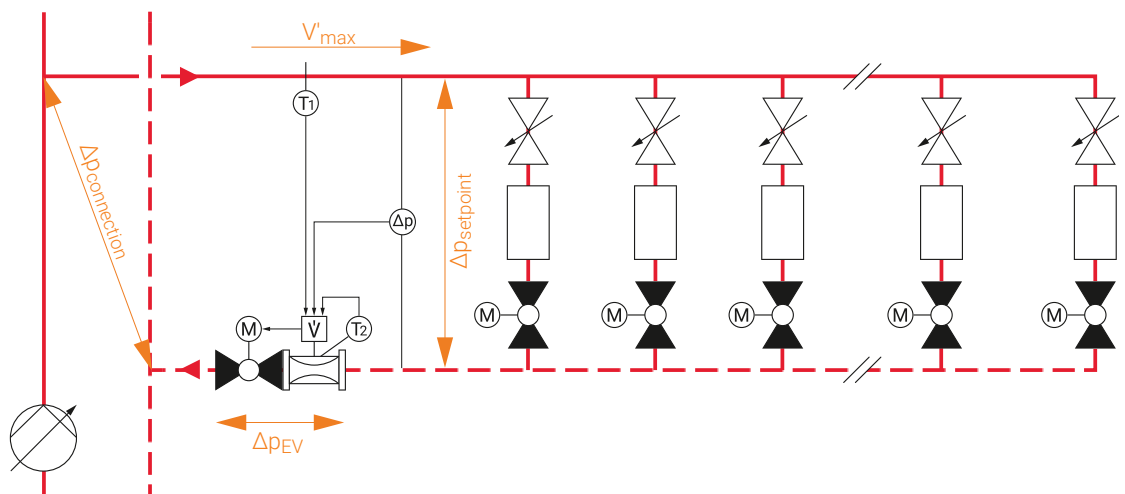

To select a suitable Energy Valve, the required Cv value must be calculated. The sizing is made for nominal flow.

Required specifications:

- Nominal flow V'_{max} in the branch
- Desired differential pressure $dp_{setpoint}$ between the measurement points
- System differential pressure $dp_{connection}$ between the connection points of the system segment

1. Calculation of the necessary pressure drop across the Energy Valve

$$- dp_{EV} = dp_{connection} - dp_{setpoint}$$

Note: If additional high pressure losses occur between $dp_{connection}$ and $dp_{setpoint}$ (e.g. long pipeline), these must also be taken into account.

2. Calculation of the necessary flow coefficient of the Energy Valve $C_{V_{EV}}$

$$C_{V_{EV}} = \frac{V'_{max}}{\sqrt{\Delta p_{EV}}}$$

3. Selection of the Energy Valve
 – The previously calculated $C_{V_{EV}}$ must be less than the $C_{V_{theor.}}$ of the selected valve type.

$C_{V_{theor.}}$ and V'_{max} for differential pressure control with Energy Valve

Model	Size	$C_{V_{theor.}}$ [GPM]	V'_{max} range [GPM]
EV050+...	½" [DN 15]	3.67	1.65...6.6
EV075+...	¾" [DN 20]	6.17	2.7...11
EV100+...	1" [DN 25]	10.14	4.5...18.2
EV125+...	1¼" [DN 32]	16.32	7.1...28.5
EV150+...	1½" [DN 40]	22.18	11...44
EV200+...	2" [DN 50]	35.20	16.5...66
EV200+...	2" [DN 50]	35.20	25...100

For the best possible control capability, the smallest possible nominal diameter should be selected. V'_{max} must also be considered.

Example: $V'_{max} = 40.9$ GPM

$\Delta p_{setpoint} = 6.5$ PSI

$\Delta p_{connection} = 15.9$ PSI

1. $\Delta p_{EV} = \Delta p_{connection} - \Delta p_{setpoint} = 15.9 \text{ PSI} - 6.5 \text{ PSI} = 9.4 \text{ PSI}$

2.
$$C_{V_{EV}} = \frac{V'_{max}}{\sqrt{\Delta p_{EV}}} = \frac{40.9}{\sqrt{9.4}} = 13.3 \text{ GPM}$$

3. Selection EV150+... ($C_{V_{theor.}} = 22.18 / V'_{max} = 11...44$)

Confirmation:

$C_{V_{EV}}$ 13.3 less than $C_{V_{theor.}}$ ✓

V'_{max} of 40.9 in range ✓

Operating range

In differential pressure control mode, the Energy Valve automatically changes its opening position to achieve the pressure drop required to reach the desired differential pressure setpoint. The flow that occurs is specified by the system segment supplied. The following limitations must be taken into account:

Maximum flow

- The specified V'_{nom} value of the Energy Valve must not be exceeded.

Minimum flow with flow reduction

- Reduction of the flow through the control valves in the system segment
- Differential pressure control is carried out up to a minimum flow of $0.7\% V'_{nom}$

Behaviour when the minimum flow is undercut

- The position of the angle reached at 0.7% of V'_{nom} is retained ("freeze position")

Start-up behaviour after the flow has fallen below the minimum flow

Differential pressure control mode is resumed when a differential pressure is present and one of the following conditions is met:

- The measured flow is higher than $1.2\% V'_{nom}$
- or
- The measured differential pressure is less than 50% of the differential pressure setpoint and a flow of at least $0.2\% V'_{nom}$ is detected.

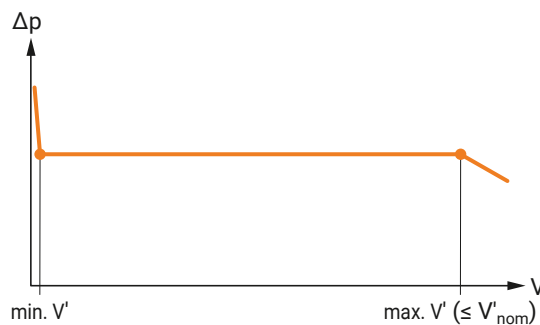

Differential pressure control operating range

Note:

- In differential pressure control mode, the valve is never completely closed
- Instead of the "freeze position" described above, an actuator position of 27% is approached as the starting position for control operation if:
 - The valve has been restarted
 - After a voltage interruption
 - The manual override was previously operated
 - Switching from another control mode (e.g. flow control) to differential pressure control mode
 - No differential pressure is present at a flow $< 0.7\% V'_{nom}$
- If the flow cannot be measured due to a malfunction in the flow sensor or due to air bubbles in the system, the differential pressure is controlled within the valve opening range from 27% to 100%
- The actuator switches from actuator position of 27% to control mode if a differential pressure is present and one of the following conditions is met (both for at least 30 seconds):
 - The measured flow is higher than $0.7\% V'_{nom}$
 - or
 - The measured differential pressure is less than 50% of the differential pressure setpoint and a flow of at least $0.2\% V'_{nom}$ is detected

Integration

In differential pressure operating mode, the Energy Valve is operated as a stand-alone device without external control signal. It can be integrated to enable simple access to all operating data and measured values or easily adjust the setpoint. The following communicative interfaces are available in every Energy Valve.

- BACnet/IP, BACnet MS/TP
- Modbus TCP, Modbus RTU
- MP-Bus

Information regarding integration can be found in the following documents:

- Data sheet Energy Valve
- Installation instructions Energy Valve
- MP-Bus Data-Pool Values
- Modbus interface description
- BACnet interface description

In addition to the interface, the analog feedback signal U can be used to display **one** of the following measured values:

- Differential pressure
- Heating/cooling power ¹⁾
- Flow
- Actuator position
- Supply temperature
- Return temperature
- Differential temperature

¹⁾ of the connected system segment

Installation

When installing the differential pressure sensor, the corresponding installation instructions are to be observed. The connection of the differential pressure sensor is described in the installation instructions for the Energy Valve.

Installation 22WDP-51..

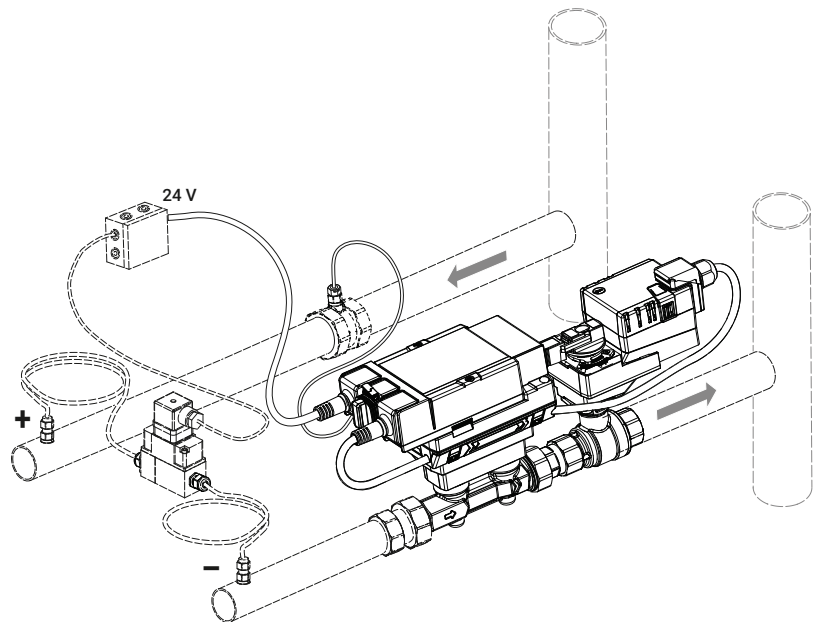

Installation 22WDP-51..

Commissioning / Value setting

Commissioning / Value setting with the web server

Detailed information regarding the web server can be found in the "Web Server instructions – Belimo Energy Valve™ / Thermal Energy Meter" document. The specific settings for differential pressure control are described in the following.

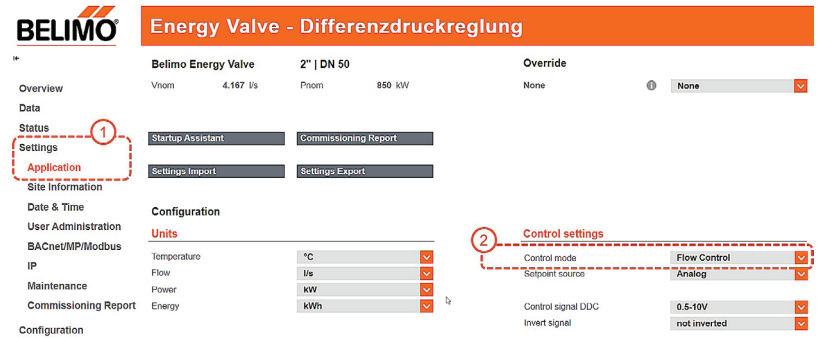

Web server – changing the control mode (step 1)

Control settings

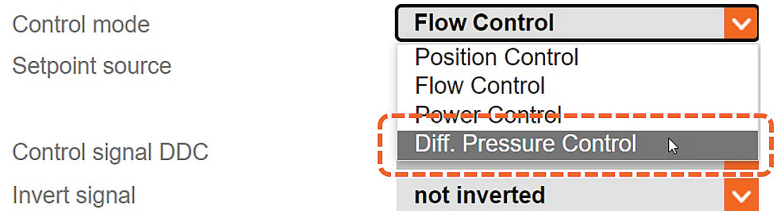

Web server – changing the control mode (step 2)

Control settings

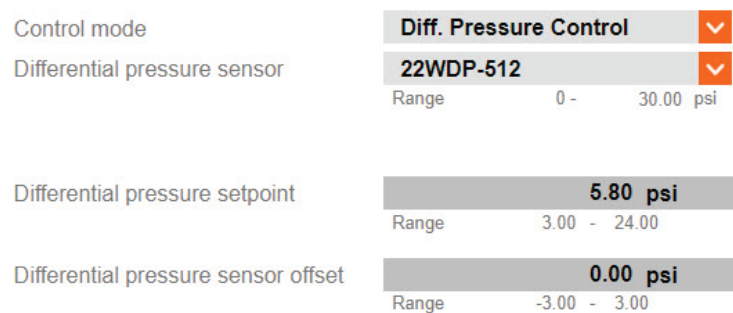

Web server – differential pressure control setting

1. Selection of the installed differential pressure sensor
2. Adjustment of the desired differential pressure setpoint
3. Possibility of correcting sensor drift

Maximum and limitation

V _{max}	1.387 gpm	①
Range	1.387 - 5.548	
P _{max}	853.0 BTU/h	②
Range	853.0 - 170607.1	

Web server – limitation function setting

1. Definition of the maximum flow V'_{\max}
 - When the set V'_{\max} value is reached, the differential pressure is not increased any further, even if the setpoint has not yet been reached
 - Factory setting $V'_{\max} = V'_{\text{nom}}$
2. Definition of the maximum heating/cooling power P'_{\max} in the corresponding system segment
 - When the maximum power is reached, the differential pressure is not increased any further, even if it falls below the setpoint
 - Factory setting $P'_{\max} = P'_{\text{nom}}$

If no specific limitations are required, no settings need to be made here.

Commissioning / Value setting with Belimo Assistant App

The above settings can also be made quickly and intuitively using the Belimo Assistant App.

Value setting with BACnet, Modbus, or MP-Bus

The settings can be changed via bus using the corresponding data points.

Value setting by means of Belimo Cloud

For devices connected to the Belimo Cloud, settings can be made from any location.

Restrictions

- Delta T manager is not available in differential pressure control operating mode.
- Specially configured control parameters ensure stable control quality. However, they are not designed for rapid control processes, i.e. domestic water control.
- Series connection of the electronic differential pressure controller with other electronic pressure-independent control valves in flow control or power control is not recommended.

All inclusive.

Belimo as a global market leader develops innovative solutions for the controlling of heating, ventilation and air-conditioning systems. Damper actuators, control valves, sensors and meters represent our core business.

Always focusing on customer value, we deliver more than only products. We offer you the complete product range for the regulation and control of HVAC systems from a single source. At the same time, we rely on tested Swiss quality with a five-year warranty. Our worldwide representatives in over 80 countries guarantee short delivery times and comprehensive support through the entire product life. Belimo does indeed include everything.

The "small" Belimo devices have a big impact on comfort, energy efficiency, safety, installation and maintenance.

In short: Small devices, big impact.



5-year warranty



On site around the globe



Complete product range



Tested quality



Short delivery times



Comprehensive support



Belimo Americas

USA, Canada, Brazil, Latin America, and the Caribbean

www.belimo.com

**BELIMO**[®]